

BGA7L1N6

Single-Band LTE LNA

Single Band LTE LNA BGA7L1N6
Supporting Band-5 (869-894 MHz)
Using 0201 Components

Application Note AN351

Revision: Rev. 1.0
2013-11-13

Table of Content

1	Introduction	4
1.1	Introduction About 3G and 4G	4
1.2	Applications	6
1.3	Infineon LNAs for 3G, 4G LTE and LTE-A Applications	7
2	BGA7L1N6 Overview	10
2.1	Features	10
2.2	Description	10
3	Application Circuit and Performance Overview	13
3.1	Summary of Measurement Results.....	13
3.2	BGA7L1N6 as LTE LNA for Band-5 (869-894 MHz).....	15
3.3	Schematics and Bill-of-Materials.....	16
4	Measurement Graphs	17
5	Evaluation Board and Layout Information	25
6	Authors	26
7	Remark	26

List of Figures

Figure 1	Example of Application Diagram of RF Front-End for 3G and 4G Systems.....	6
Figure 2	BGA7L1N6 in TSNP-6-2	10
Figure 3	Equivalent Circuit of BGA7L1N6.....	11
Figure 4	Package and Pin Connections of BGA7L1N6.....	11
Figure 5	Footprint Recommendation of BGA7L1N6	12
Figure 6	Schematics of the BGA7L1N6 Application Circuit	16
Figure 7	Insertion Power Gain (Narrowband) of the BGA7L1N6 for Band-5 Applications.....	17
Figure 8	Insertion Power Gain (Wideband) of the BGA7L1N6 for Band-5 Applications	17
Figure 9	Noise Figure of the BGA7L1N6 for Band-5 Applications	18
Figure 10	Input Matching of the BGA7L1N6 for Band-5 Applications	18
Figure 11	Input Matching (Smith Chart) of the BGA7L1N6 for Band-5 Applications	19
Figure 12	Output Matching of the BGA7L1N6 for Band-5 Applications	19
Figure 13	Output Matching (Smith Chart) of the BGA7L1N6 for Band-5 Applications	20
Figure 14	Reverse Isolation of the BGA7L1N6 for Band-5 Applications.....	20
Figure 15	Stability K-factor of the BGA7L1N6 for Band-5 Applications	21
Figure 16	Stability Mu1-factor of the BGA7L1N6 for Band-5 Applications.....	21
Figure 17	Stability Mu2-factor of the BGA7L1N6 for Band-5 Applications.....	22
Figure 18	Input 1dB Compression Point of the BGA7L1N6 for Band-5 Applications with Vcc=1.8 V	22
Figure 19	Input 1dB Compression Point of the BGA7L1N6 for Band-5 Applications with Vcc=2.8 V	23
Figure 20	Input 3 rd Intercept Point of the BGA7L1N6 for Band-5 Applications with Vcc=1.8 V	23
Figure 21	Input 3 rd Intercept Point of the BGA7L1N6 for Band-5 Applications with Vcc=2.8 V	24
Figure 22	Picture of Evaluation Board (overview) , BGA7L1N6 V1.0	25
Figure 23	Picture of Evaluation Board (detailed view)	25
Figure 24	PCB Layer Stack.....	25

List of Tables

Table 1	LTE Band Assignment	4
Table 2	Infineon Product Portfolio of LNAs for 4G LTE and LTE-A Applications	8
Table 3	Infineon Product Portfolio of LNAs for 3G and 4G Applications	9
Table 4	Pin Assignment of BGA7L1N6.....	12
Table 5	Electrical Characteristics at Room Temperature ($T_A = 25\text{ }^\circ\text{C}$) for.....	13
Table 6	Electrical Characteristics at Room Temperature ($T_A = 25\text{ }^\circ\text{C}$) for.....	14
Table 7	Bill-of-Materials.....	16

1 Introduction

1.1 Introduction About 3G and 4G

The mobile technologies for smartphones have seen tremendous growth in recent years. The data rate required from mobile devices has increased significantly over the evolution modern mobile technologies, starting from the first 3G/3.5G technologies (UMTS & WCDMA, HSPA & HSPA+) to the recently 4G LTE-Advanced (LTE-A). LTE-A can support data rates of up to 1 Gbps.

Advanced technologies such as diversity Multiple Input Multiple Output (MIMO) and Carrier Aggregation (CA) are adopted to achieve such higher data rate requirements. MIMO technology, commonly referred as the diversity path in smartphones, has attracted attention for the significant increasement in data throughput and link range without additional bandwidth or increased transmit power. The technology supports scalable channel bandwidth, between 1.4 and 20 MHz. The ability of 4G LTE to support bandwidths up to 20 MHz and to have more spectral efficiency by using high order modulation methods like QAM-64 is of particular importance as the demand for higher wireless data speeds continues to grow fast. Carrier aggregation used in LTE-Advanced combines up to 5 carriers and widens bandwidths up to 100 MHz to increase the user rates, across FDD and TDD.

Countries all over the world have released various frequencies bands for the 4G applications. **Table 1** shows the band assignment for the LTE bands worldwide.

Table 1 **LTE Band Assignment**

Band No.	Uplink Frequency Range	Downlink Frequency Range	Comment
1	1920-1980 MHz	2110-2170 MHz	FDD
2	1850-1910 MHz	1930-1990 MHz	FDD
3	1710-1785 MHz	1805-1880 MHz	FDD
4	1710-1755 MHz	2110-2155 MHz	FDD
5	824-849 MHz	869-894 MHz	FDD
6	830-840 MHz	875-885 MHz	FDD
7	2500-2570 MHz	2620-2690 MHz	FDD
8	880-915 MHz	925-960 MHz	FDD
9	1749.9-1784.9 MHz	1844.9-1879.9 MHz	FDD

Table 1 LTE Band Assignment

Band No.	Uplink Frequency Range	Downlink Frequency Range	Comment
10	1710-1770 MHz	2110-2170 MHz	FDD
11	1427.9-1452.9 MHz	1475.9-1500.9 MHz	FDD
12	698-716 MHz	728-746 MHz	FDD
13	777-787 MHz	746-756 MHz	FDD
14	788-798 MHz	758-768 MHz	FDD
17	704-716 MHz	734-746 MHz	FDD
18	815-830 MHz	860-875 MHz	FDD
19	830-845 MHz	875-890 MHz	FDD
20	832-862 MHz	791-821 MHz	FDD
21	1447.9-1462.9 MHz	1495.9-1510.9 MHz	FDD
22	3410-3500 MHz	3510-3600 MHz	FDD
23	2000-2020 MHz	2180-2200 MHz	FDD
24	1626.5-1660.5 MHz	1525-1559 MHz	FDD
25	1850-1915 MHz	1930-1995 MHz	FDD
26	814-849 MHz	859-894 MHz	FDD
27	807-824 MHz	852-869 MHz	FDD
28	703-748 MHz	758-803 MHz	FDD
29	N/A	716-728 MHz	FDD
33	1900-1920 MHz		TDD
34	2010-2025 MHz		TDD
35	1850-1910 MHz		TDD
36	1930-1990 MHz		TDD
37	1910-1930 MHz		TDD
38	2570-2620 MHz		TDD
39	1880-1920 MHz		TDD
40	2300-2400 MHz		TDD
41	2496-2690 MHz		TDD
42	3400-3600 MHz		TDD
43	3600-3800 MHz		TDD
44	703-803 MHz		TDD

In order to cover all the bands from different countries in a unique device, mobile phones and data cards are usually equipped more bands and band combinations. Some typical examples are quad-band combinations of band 1/2/5/8, 1/3/5/7 and 3/7/5/17. The frequency bands used by TD-LTE are 3.4–3.6 GHz in Australia and UK, 2.57–2.62 GHz in the US and China, 2.545-2.575 GHz in Japan, and 2.3–2.4 GHz in India and Australia.

1.2 Applications

Figure 1 shows an example of the block diagram of the front-end of a 4G modem. A SPnT switch connects one side the antenna and several duplexers for different 4G bands on the other side. Every duplexer is connected to the transmitting (TX) and receiving (RX) paths of each band. The external LNA, here for example Infineon single-band LNA BGA7L1N6, is placed on the RX path between the duplex and the bandpass SAW filter. The output of the SAW filter is connected to the receiver input of the transceiver IC.

Depending on the number of bands designed in a device, various numbers of LNAs are required in a system. Recently, even mobile devices with 5 modes 13 bands are under discussion. Not only for the main paths, but also for the diversity pathes, the external LNAs are widely used to boost end user experience while using mobile devices for video and audio streaming.

Besides low noise amplifiers, Infineon Technologies also offers solutions for high power highly linear antenna switches, band switches as well as power detection diodes for power amplifiers.

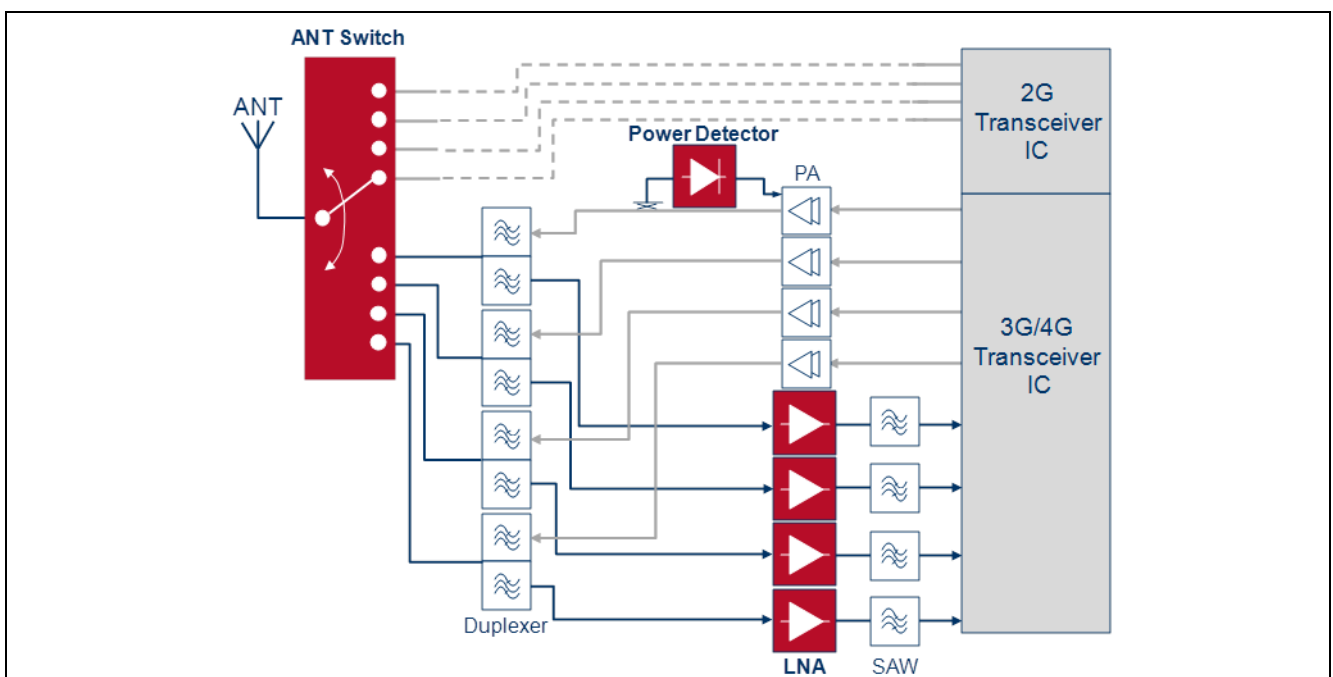

Figure 1 Example of Application Diagram of RF Front-End for 3G and 4G Systems.

1.3 Infineon LNAs for 3G, 4G LTE and LTE-A Applications

With the increasing wireless data speed and with the extended link distance of mobile phones and 4G data cards, the requirements on the sensitivity are much higher. Infineon offers different kind of low noise amplifiers (LNAs) to support the customers for mobile phones and data cards of 4G LTE and LTE-A to improve their system performance to meet the requirements coming from the networks/service providers.

The benefits to use external LNAs in equipment for 4G LTE and LTE-A applications are:

- Flexible design to place the front-end components: due to the size constraint, the modem antenna and the front-end can not be always put close to the transceiver IC. The path loss in front of the integrated LNA on the transceiver IC increases the system noise figure noticeably. An external LNA physically close to the antenna can help to eliminate the path loss and reduce the system noise figure. Therefore the sensitivity can be improved by several dB.
- Support RX carrier aggregation where two LNAs can be tuned on at the same time.
- Boost the sensitivity by reducing the system noise figure: external LNA has lower noise figure than the integrated LNA on the transceiver IC.
- Bug fix to help the transceiver ICs to fulfill the system requirements.
- Increase the dynamic range of the power handling.

Infineon Technologies is the leading company with broad product portfolio to offer high performance SiGe:C bipolar transistor LNAs and MMIC LNAs for various wireless applications by using the industrial standard silicon process. The MMIC LNA portfolio includes:

- New generation single band LTE LNAs like BGA7H1N6 for high-band (HB, 2300-2700 MHz), BGA7M1N6 for mid-band (MB, 1805-2200 MHz) and BGA7L1N6 for low-band (LB, 728-960 MHz) are available.
- New generation LTE LNA Banks are quad-band. Currently there are six different types of these new LTE LNAs which are shown in **Table 2**. Each LNA bank combines four various bands LNA from the high-band (HB, 2300-2700 MHz), mid-band (MB, 1805-2200 MHz) and

low-band (LB, 728-960 MHz). Two of the four LNAs in one LNA bank can be turned on at the same time to support carrier aggregation.

The broad product portfolio with highest integration and best features in noise figure and flexible band selection helps designers to design mobile phones and data cards with outstanding performance. Therefore Infineon LNAs and LNA banks are widely used by mobile phone vendors.

Table 2 Infineon Product Portfolio of LNAs for 4G LTE and LTE-A Applications

Frequency Range	728 MHz–960 MHz	1805MHz–2200MHz	2300 MHz–2690 MHz	Comment
Single-Band LNA				
BGA7L1N6	1X			
BGA7M1N6		1X		
BGA7L1N6			1X	
Quad-Band LNA bank				
BGM7MLLH4L12	1X	2X	1X	
BGM7LMHM4L12	1X	2X	1X	
BGM7HHMH4L12		1X	3X	
BGM7MLLM4L12	2X	2X		
BGM7LLHM4L12	2X	1X	1X	
BGM7LLMM4L12	2X	2X		

In addition, the older generation of LTE LNAs are featured with gain switching functions which is often helpful for the cases that strong or weak signal environment could happen in the field. **Table 3** shows the available band combinations:

- Single-band LNAs like BGA777L7 / BGA777N7 for high-band (2300-2700 MHz), BGA711L7 / BGA711N7 for mid-band (MB, 1700-2300 MHz) and BGA751L7 / BGA751N7, BGA728L7/BGA728N7, BGA713L7/BGA713N7 for low-band (LB, 700-1000 MHz) are available.

- Dual-band LNA BGA771L16 supports 1x mid-band (MB, 1700-2300 MHz) and 1x low-band (LB, 700-1000 MHz).

- Triple-band LNAs BGA734N16, BGA735N16 and BGA736N16 are available to cover the most bands. All of the three triple-band LNAs can support designs covering 2x high-bands and 1x low-band.

- Both BGA748N16 and BGA749N16 are quad-band LNAs. BGA748N16 can cover 2x high- and 2x low-bands and BGA749N16 can cover 1x high-band and 3x low-bands.

Table 3 Infineon Product Portfolio of LNAs for 3G and 4G Applications

Frequency Range	700-1000 MHz	1700-2200 MHz	2100-2700 MHz	Comment
Single-Band LNA				
BGA711N7/L7			1X	
BGA751N7/L7	1X			
BGA777N7/L7			1X	
BGA728L7/N7	1X			
BGA713L7/N7	1X			
Dual-Band LNA				
BGA771L16	1X	1X		
Triple-Band LNA				
BGA734L16	1X	1X	1X	
BGA735N16	1X	1X	1X	
BGA736N16	1X	1X	1X	
Quad-band LNA				
BGA748N16	2X	1X	1X	
BGA749N16	3X		1X	

2 BGA7L1N6 Overview

2.1 Features

- Insertion power gain: 13.3 dB
- Low noise figure: 0.90 dB
- Low current consumption: 44 mA
- Operating frequencies: 716-960 MHz
- Supply voltage: 1.5 V to 3.6 V
- Digital on/off switch (1 V logic high level)
- Ultra small TSNP-6-2 leadless package (footprint: 0.7x1.1 mm²)
- B7HF Silicon Germanium technology
- RF output internally matched to 50 Ω
- Only 1 external SMD component necessary
- 2 kV HBM ESD protection (including AI-pin)
- Pb-free (RoHS compliant) package

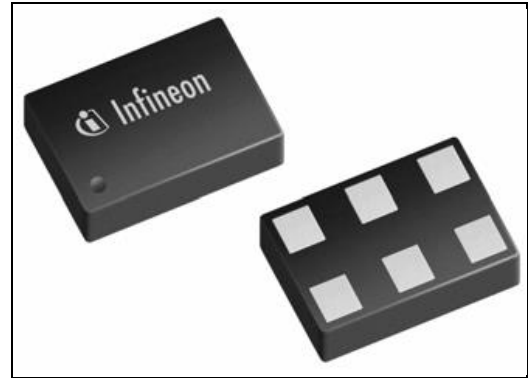

Figure 2 BGA7L1N6 in TSNP-6-2



2.2 Description

The BGA7L1N6 is a front-end low noise amplifier for LTE applications, which covers a wide frequency range from 716 MHz to 960 MHz. The LNA provides 13.3 dB gain and 0.90 dB noise figure at a current consumption of 4.9 mA in the application configuration described in **Chapter 3**. The BGA7L1N6 is based upon Infineon Technologies' B7HF Silicon Germanium technology. It operates from 1.5 V to 3.6 V supply voltage.

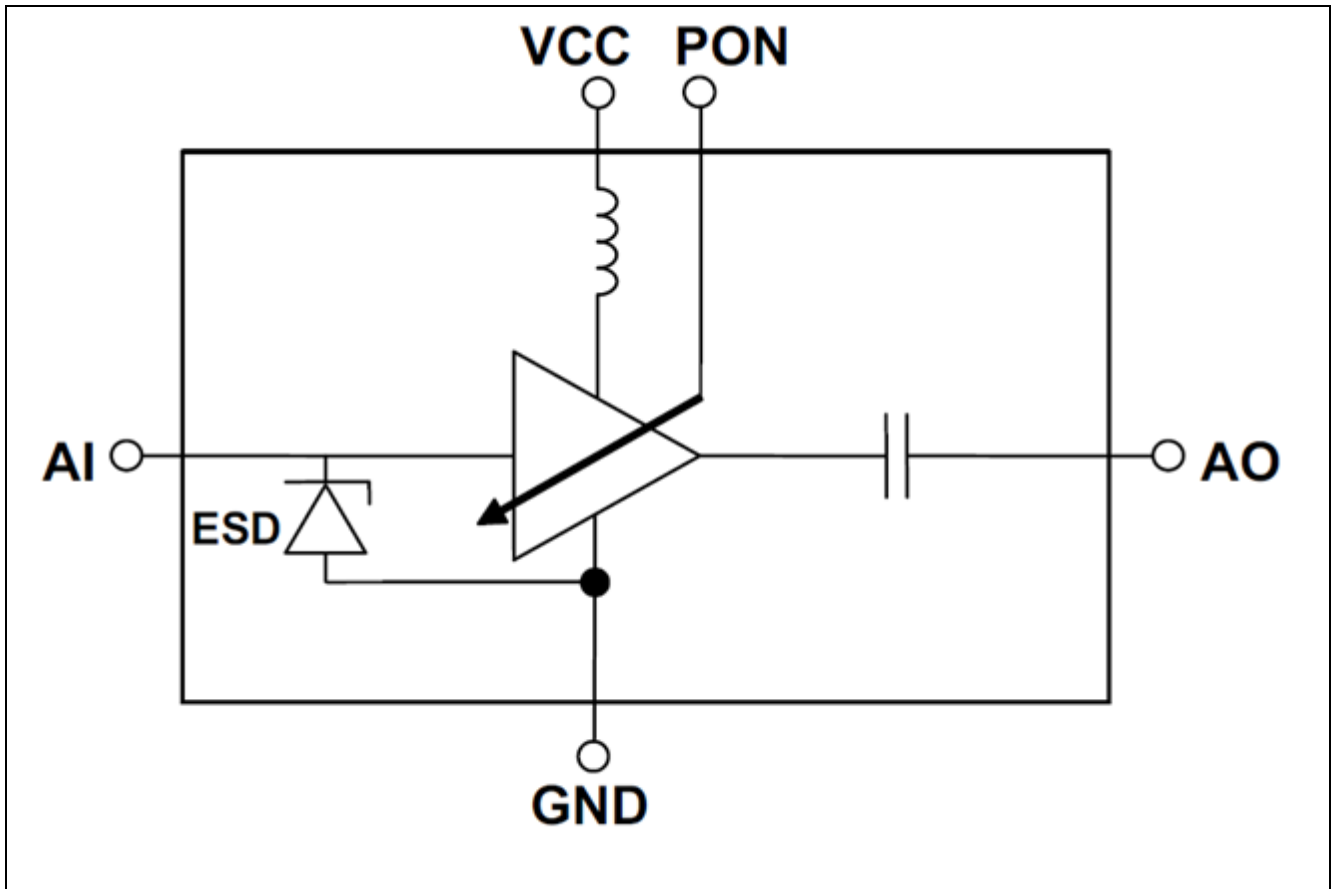

Figure 3 Equivalent Circuit of BGA7L1N6

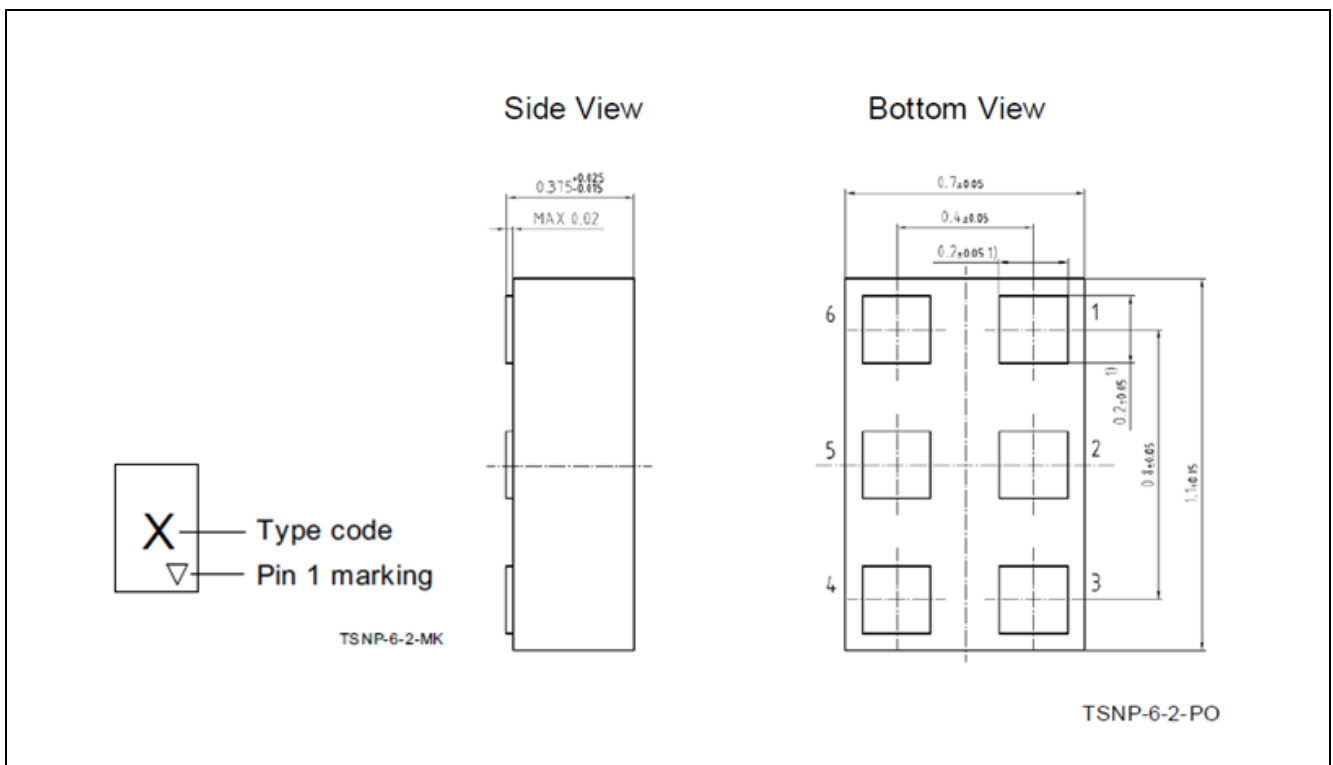

Figure 4 Package and Pin Connections of BGA7L1N6

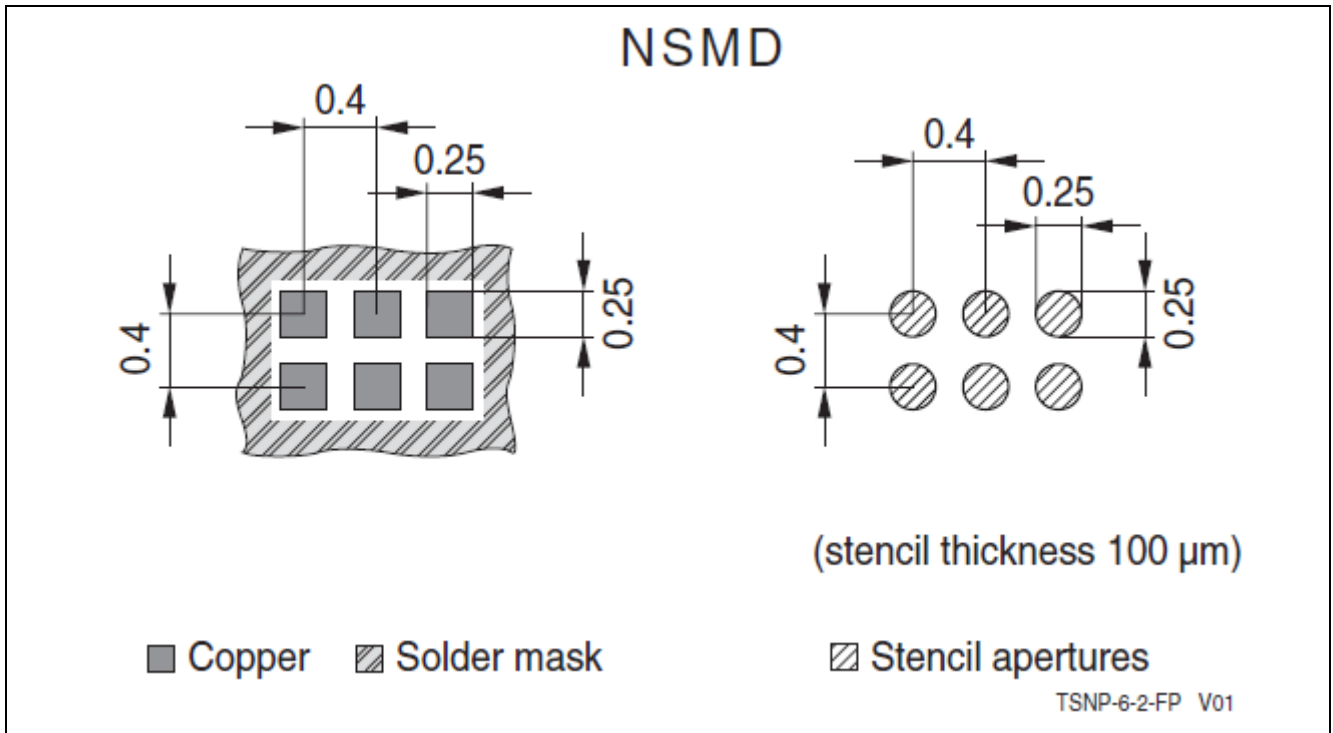

Figure 5 Footprint Recommendation of BGA7L1N6

Table 4 Pin Assignment of BGA7L1N6

Pin No.	Symbol	Function
1	GND	Ground
2	VCC	Supply voltage
3	AO	LNA output
4	GND	Ground
5	AI	LNA input
6	PON	Power on control

3 Application Circuit and Performance Overview

Device: BGA7L1N6

Application: Single Band LTE LNA BGA7L1N6 Supporting Band-5 (869-894 MHz) Using 0201 Components

PCB Marking: BGA7x1N6 V1.0

3.1 Summary of Measurement Results

Table 5 Electrical Characteristics at Room Temperature ($T_A = 25\text{ }^\circ\text{C}$) for Band-5 (869-894 MHz), $V_{CC} = 1.8\text{ V}$, $V_{EN} = 1.8\text{ V}$,

Parameter	Symbol	Value			Unit	Comment/Test Condition
DC Voltage	Vcc	1.8			V	
DC Current	Icc	4.5			mA	
Frequency Range	Freq	869	882	894	MHz	
Gain	G	12.4	12.6	12.8	dB	
Noise Figure	NF	1.07	1.08	1.09	dB	Loss of SMA and line of 0.03 dB is subtracted
Input Return Loss	RLin	16.7	19.2	22	dB	
Output Return Loss	RLout	10.7	11.8	12.9	dB	
Reverse Isolation	IRev	22	22	22	dB	
Input P1dB	IP1dB	-7.2	-9.3	-8.5	dBm	
Output P1dB	OP1dB	4.2	2.3	3.3	dBm	
Input IP3	IIP3	0.5			dBm	Power @ Input: -30 dBm $f_1=881\text{ MHz}$, $f_2=882\text{ MHz}$
Output IP3	OIP3	13.1			dBm	
Stability	k	>1			--	Measured up to 10 GHz

Table 6 Electrical Characteristics at Room Temperature ($T_A = 25\text{ °C}$) for Band-5 (869-894 MHz), $V_{CC} = 2.8\text{ V}$, $V_{EN} = 2.8\text{ V}$,

Parameter	Symbol	Value			Unit	Comment/Test Condition
DC Voltage	Vcc	2.8			V	
DC Current	Icc	4.6			mA	
Frequency Range	Freq	869	882	894	MHz	
Gain	G	12.4	12.6	12.8	dB	
Noise Figure	NF	1.07	1.07	1.08	dB	Loss of SMA and line of 0.03 dB is subtracted
Input Return Loss	RLin	15.3	17.1	19.2	dB	
Output Return Loss	RLout	10	10.9	11.9	dB	
Reverse Isolation	IRev	23	22	22	dB	
Input P1dB	IP1dB	-4.6	-5.8	-6.5	dBm	
Output P1dB	OP1dB	6.8	5.8	5.3	dBm	
Input IP3	IIP3	0.6			dBm	Power @ Input: -30 dBm $f_1=881\text{ MHz}$, $f_2=882\text{ MHz}$
Output IP3	OIP3	13.2			dBm	
Stability	k	>1			--	Measured up to 10 GHz

3.2 BGA7L1N6 as LTE LNA for Band-5 (869-894 MHz)

This application note focuses on the Infineon's Single-band LTE LNA BGA7L1N6 tuned for the band-5. It presents the performance of BGA7L1N6 with 1.8 V/2.8 V power supply with the operating current of 4.6 mA.

The application circuit requires only one 0201 passive component. The component value is fine tuned for optimal noise figure, gain, input and output matching. It has a gain of 12.8 dB. The circuit achieves input return loss better than 15.3 dB, as well as output return loss better than 10 dB. At room temperature the noise figure is 1.1 dB (SMA and PCB losses are subtracted).

Furthermore, the circuit is measured unconditionally stable till 10 GHz. At Band-5, using two tones spacing of 1 MHz, the output third order intercept point, OIP3 reaches 13.2 dBm. Input P1dB of the BGA7L1N6 LNA is about -4.6 dBm for 894 MHz. All the measurements are done with the standard evaluation board presented at the end of this application note.

3.3 Schematics and Bill-of-Materials

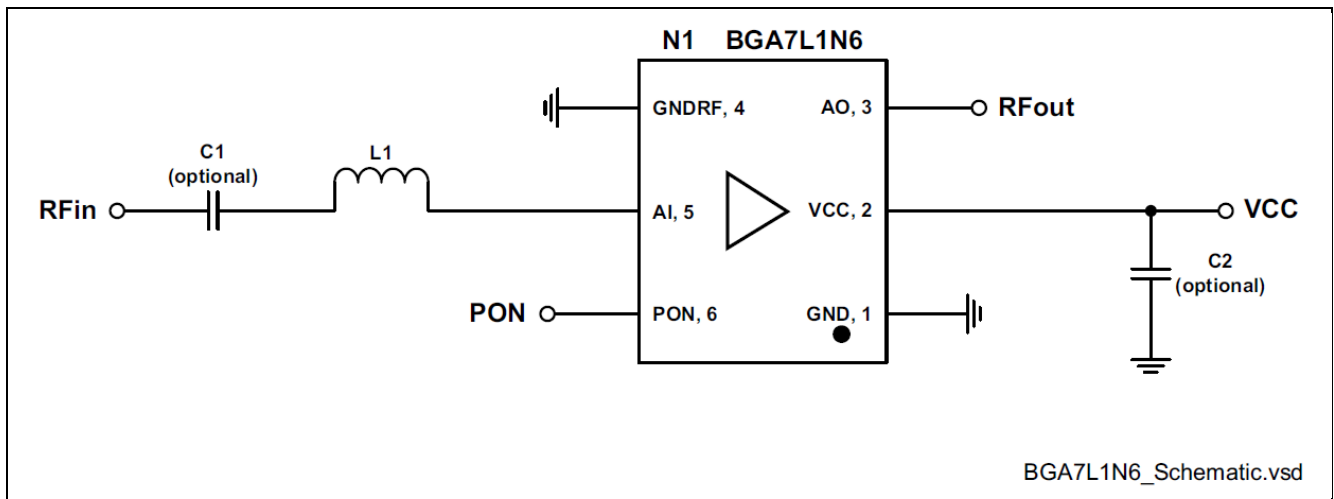

Figure 6 Schematics of the BGA7L1N6 Application Circuit

Table 7 Bill-of-Materials

Symbol	Value	Unit	Size	Manufacturer	Comment
C1 (optional)	1	nF	0201	Various	DC block
C2	100	nF	0201	Various	RF to ground
L1	18	nH	0201	Murata LQP series	Input matching
N1	BGA7L1N6	TSNP-6-2		Infineon	SiGe LNA

4 Measurement Graphs

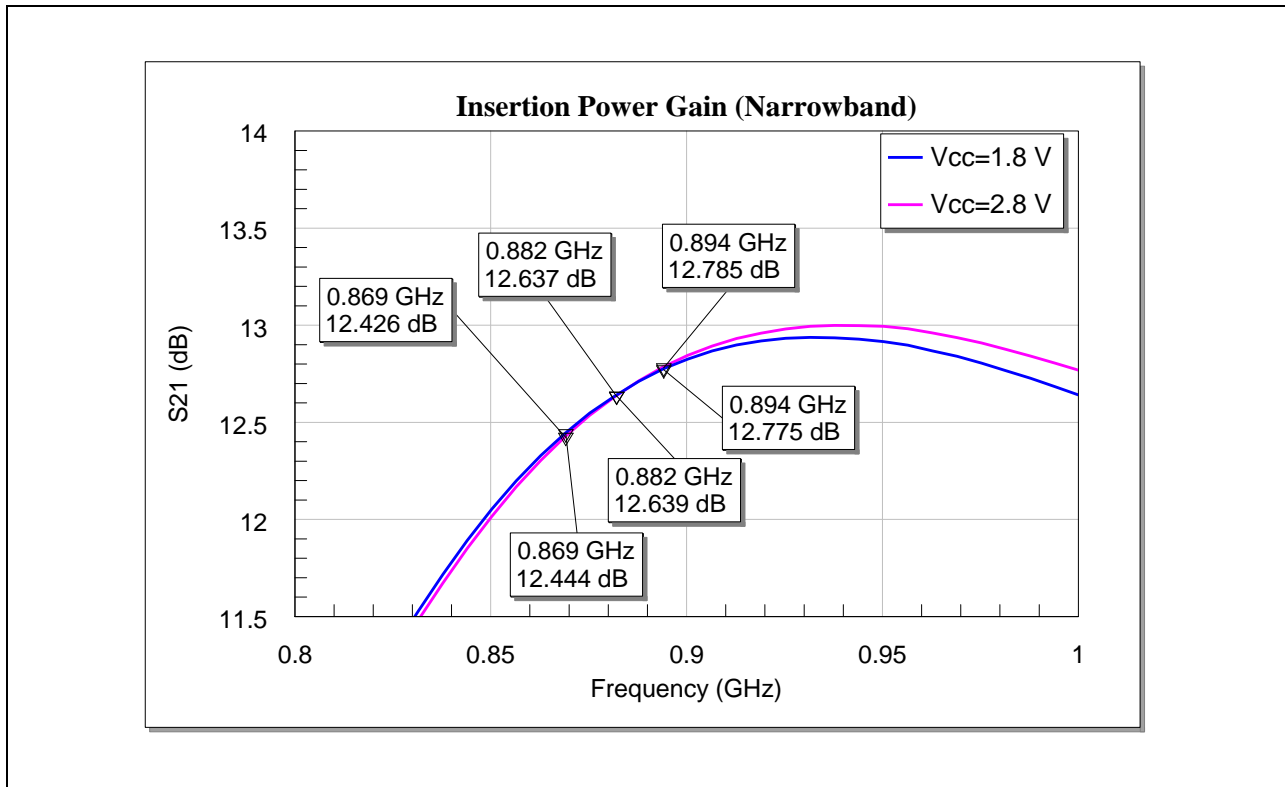

Figure 7 Insertion Power Gain (Narrowband) of the BGA7L1N6 for Band-5 Applications

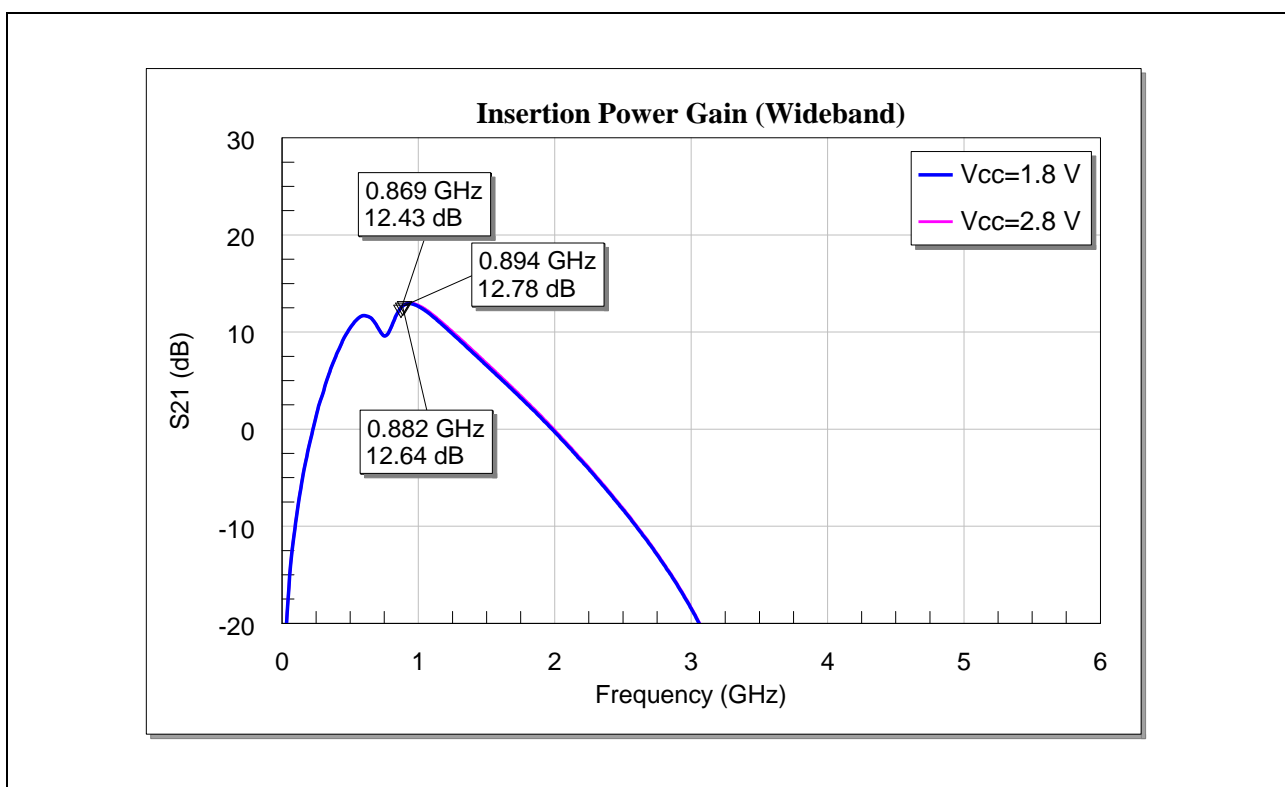

Figure 8 Insertion Power Gain (Wideband) of the BGA7L1N6 for Band-5 Applications

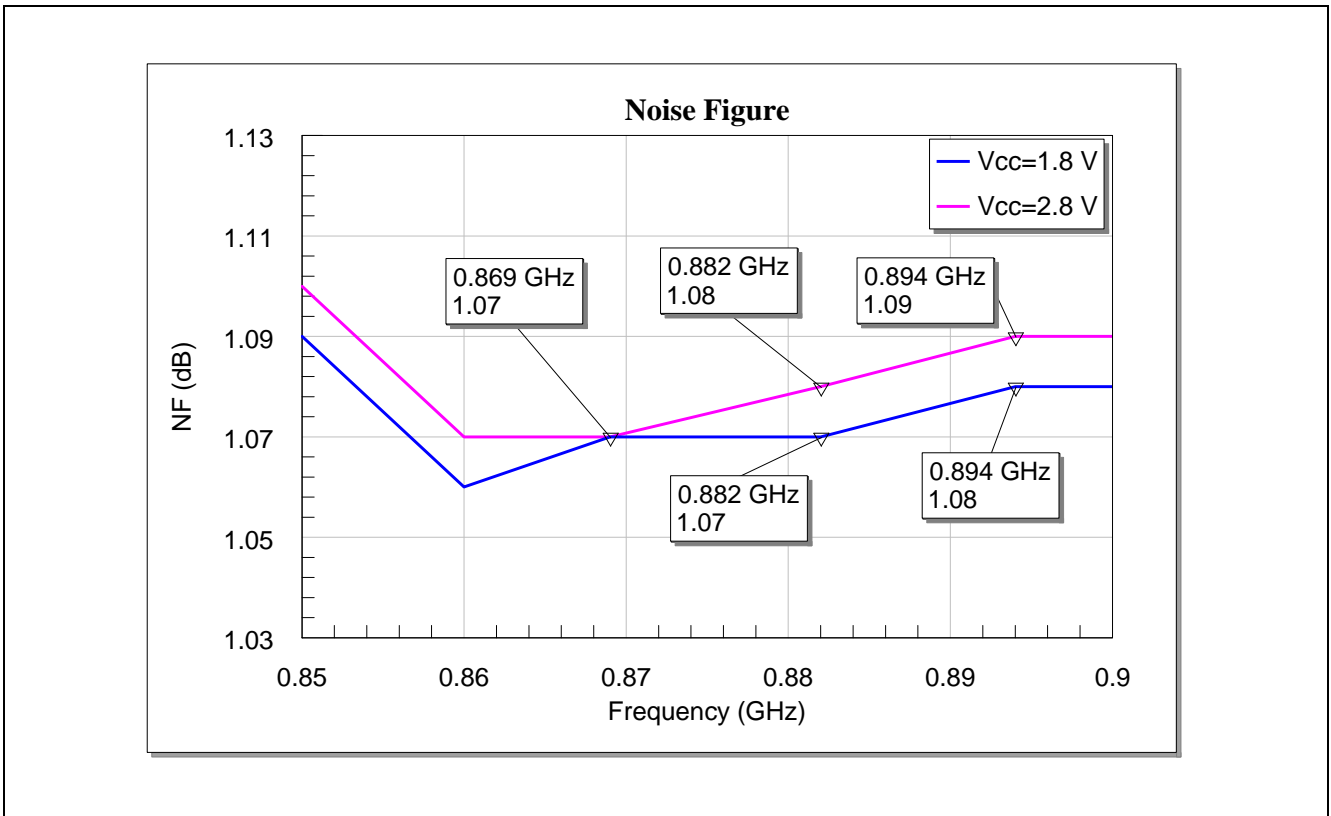

Figure 9 Noise Figure of the BGA7L1N6 for Band-5 Applications

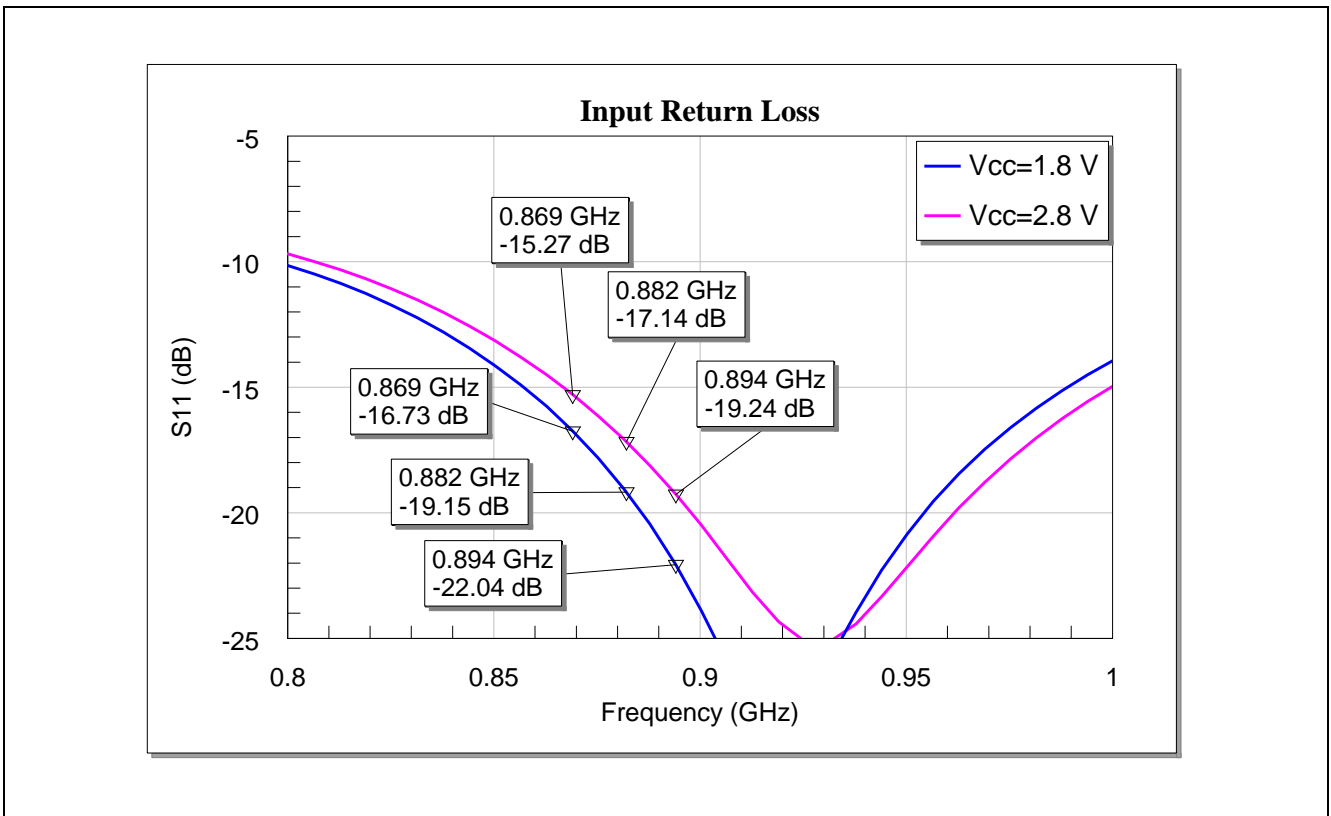

Figure 10 Input Matching of the BGA7L1N6 for Band-5 Applications

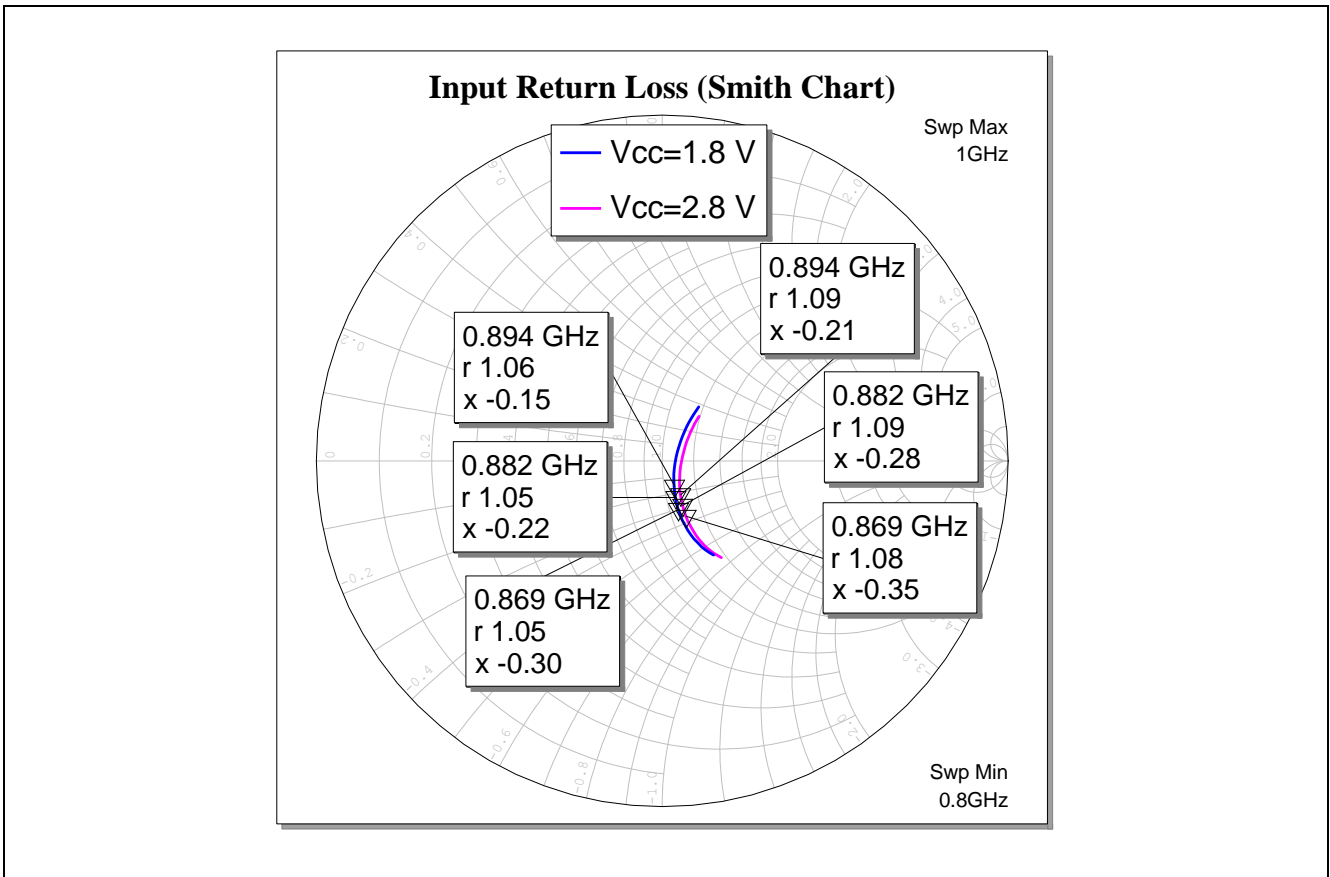

Figure 11 Input Matching (Smith Chart) of the BGA7L1N6 for Band-5 Applications

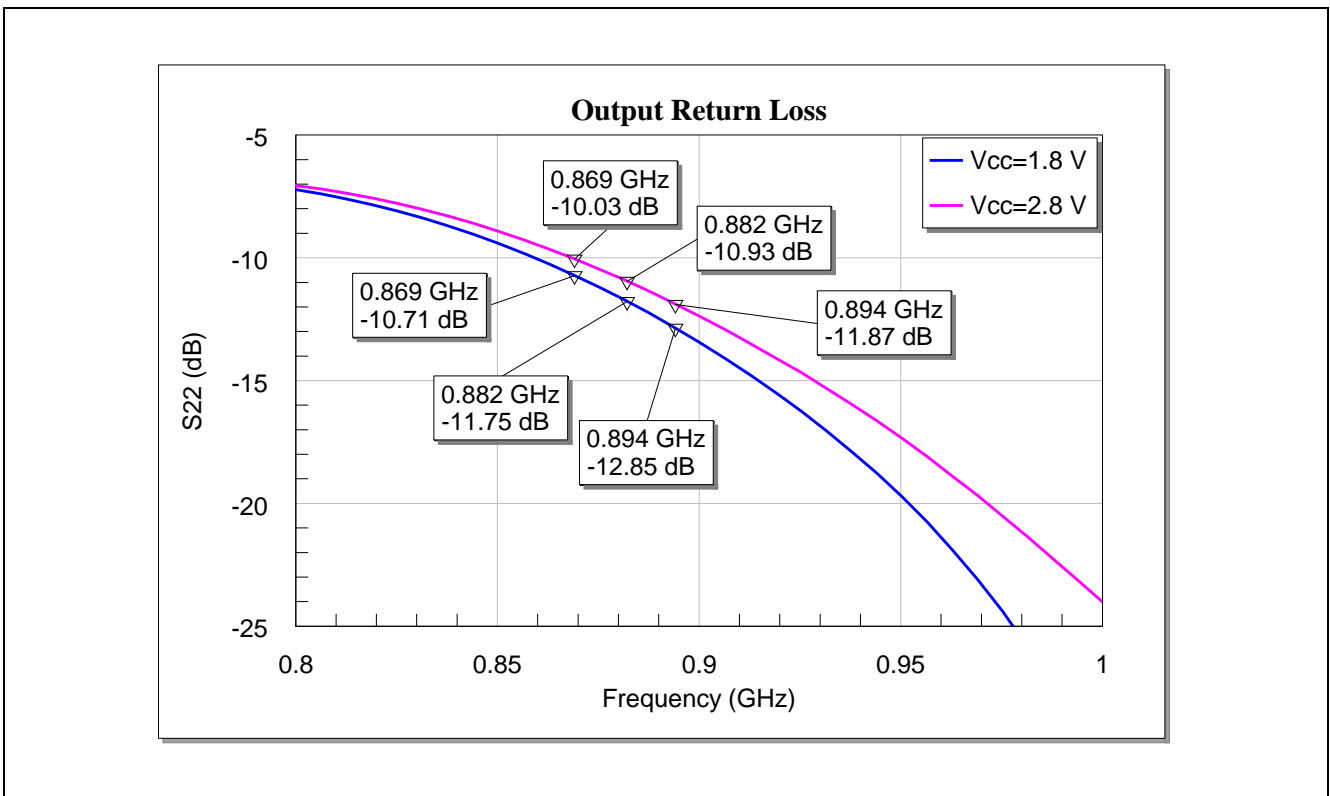

Figure 12 Output Matching of the BGA7L1N6 for Band-5 Applications

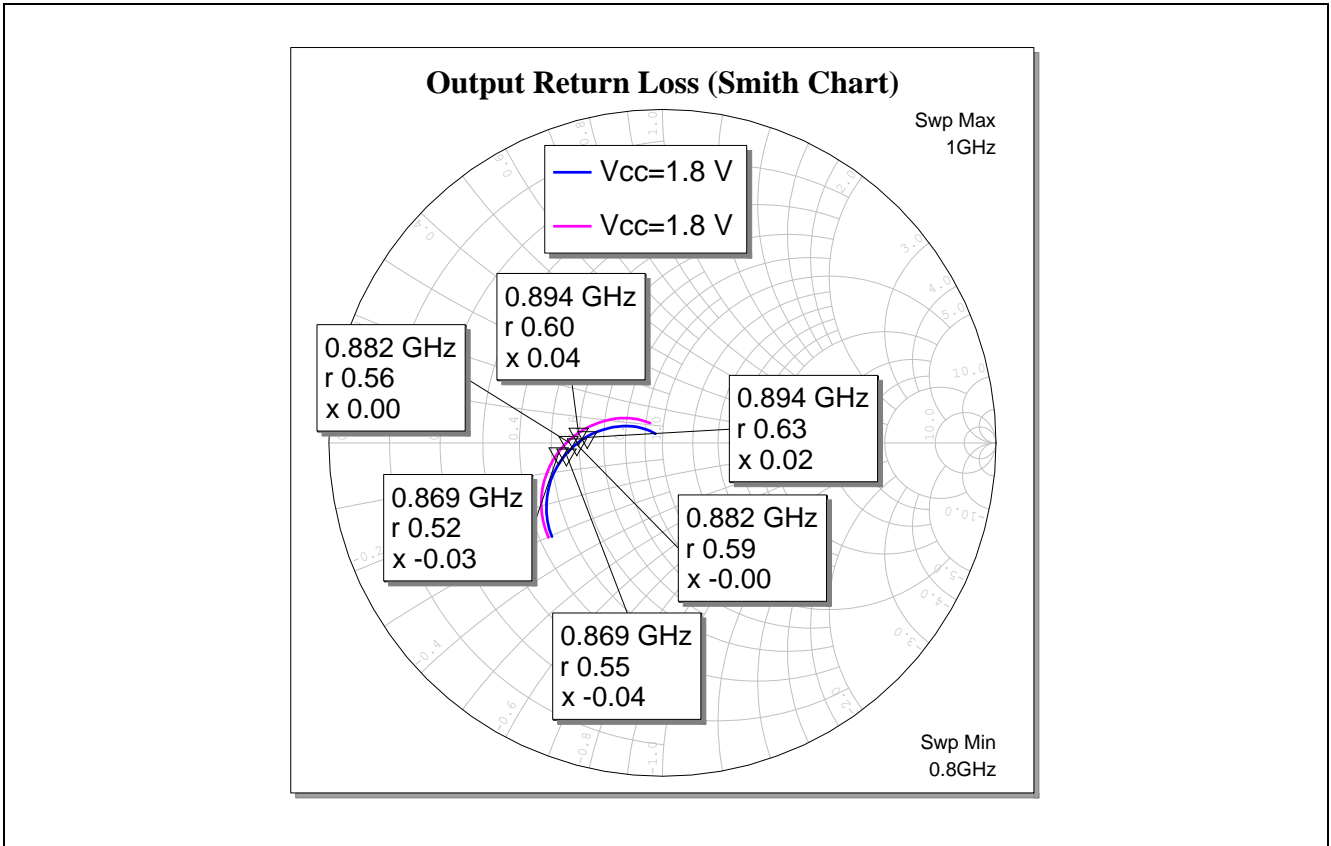

Figure 13 Output Matching (Smith Chart) of the BGA7L1N6 for Band-5 Applications

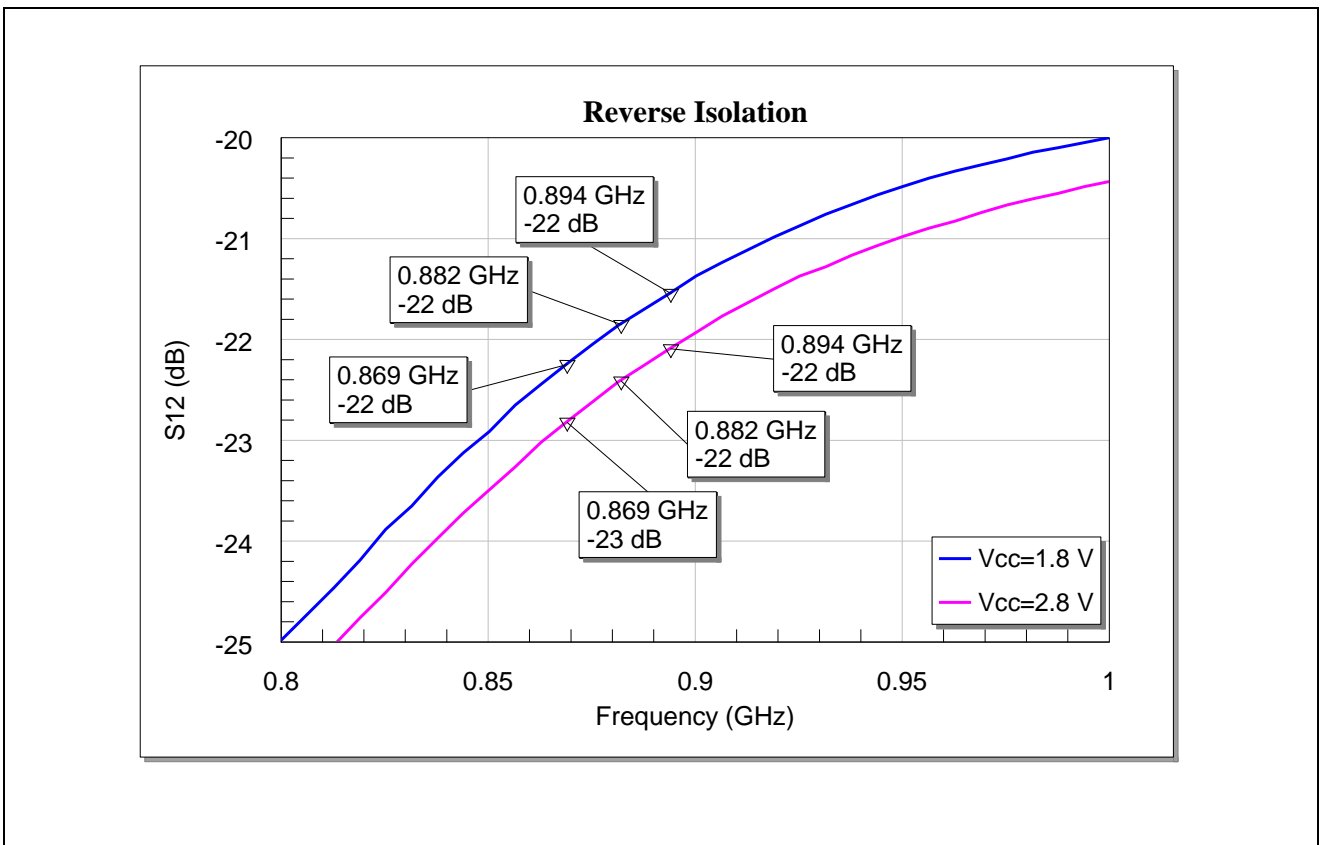

Figure 14 Reverse Isolation of the BGA7L1N6 for Band-5 Applications

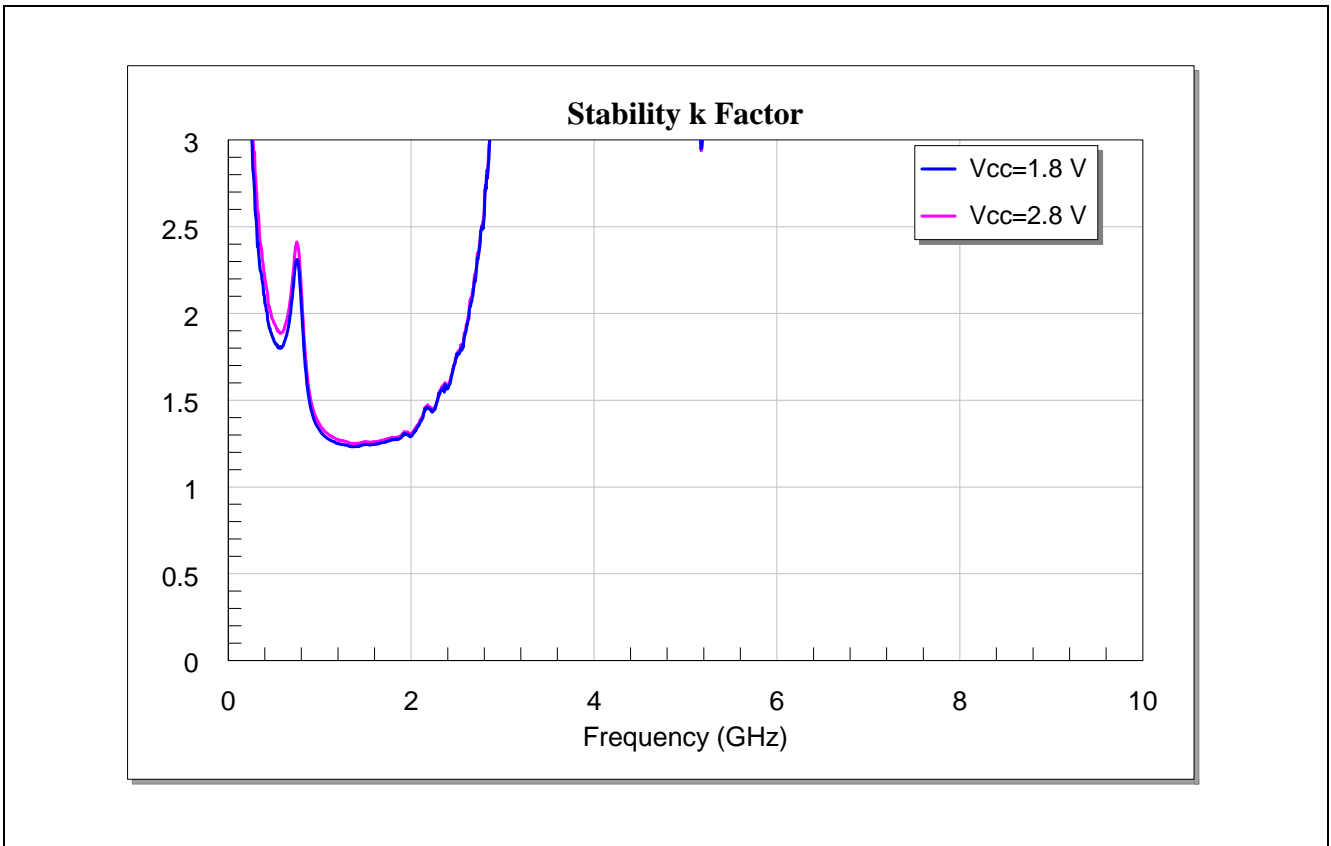

Figure 15 Stability K-factor of the BGA7L1N6 for Band-5 Applications

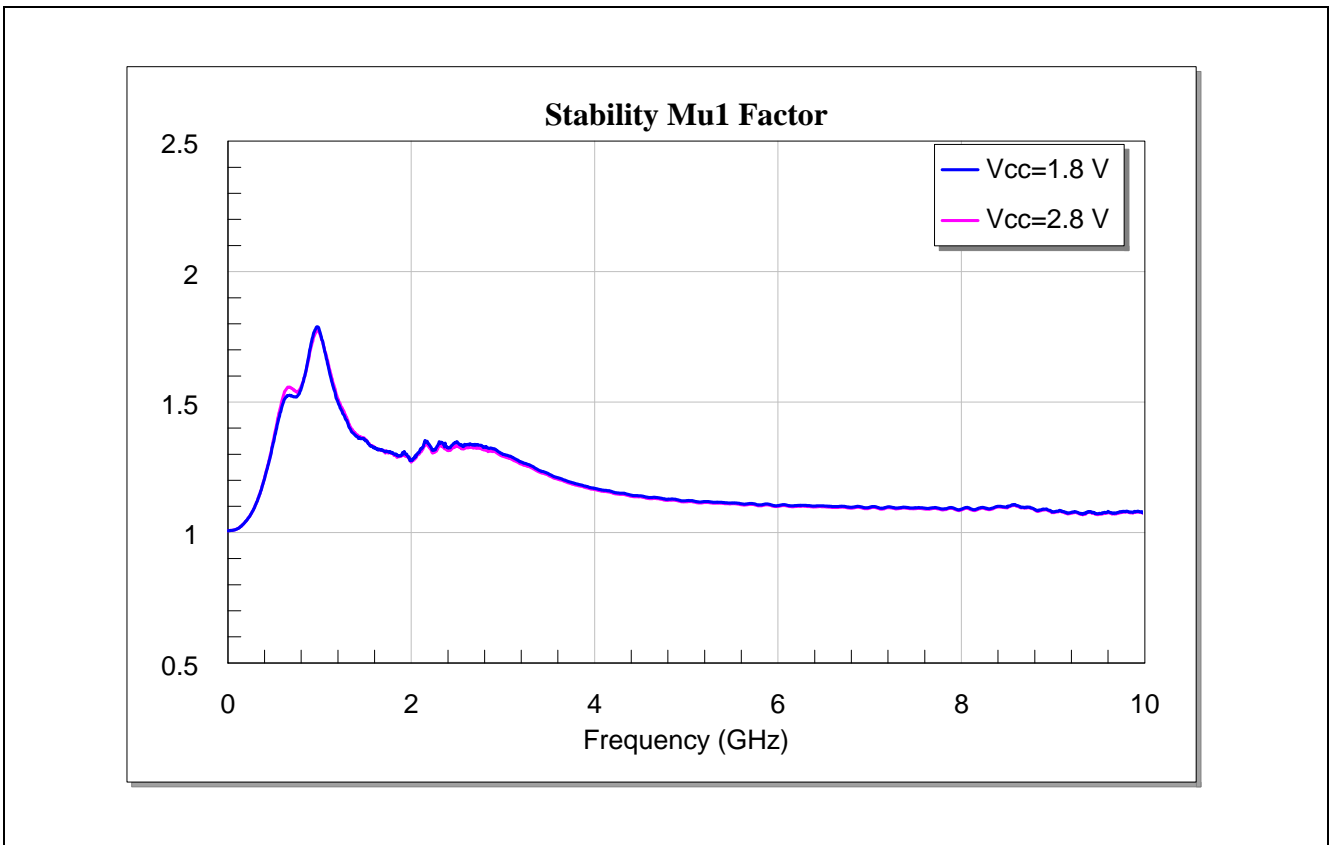

Figure 16 Stability Mu1-factor of the BGA7L1N6 for Band-5 Applications

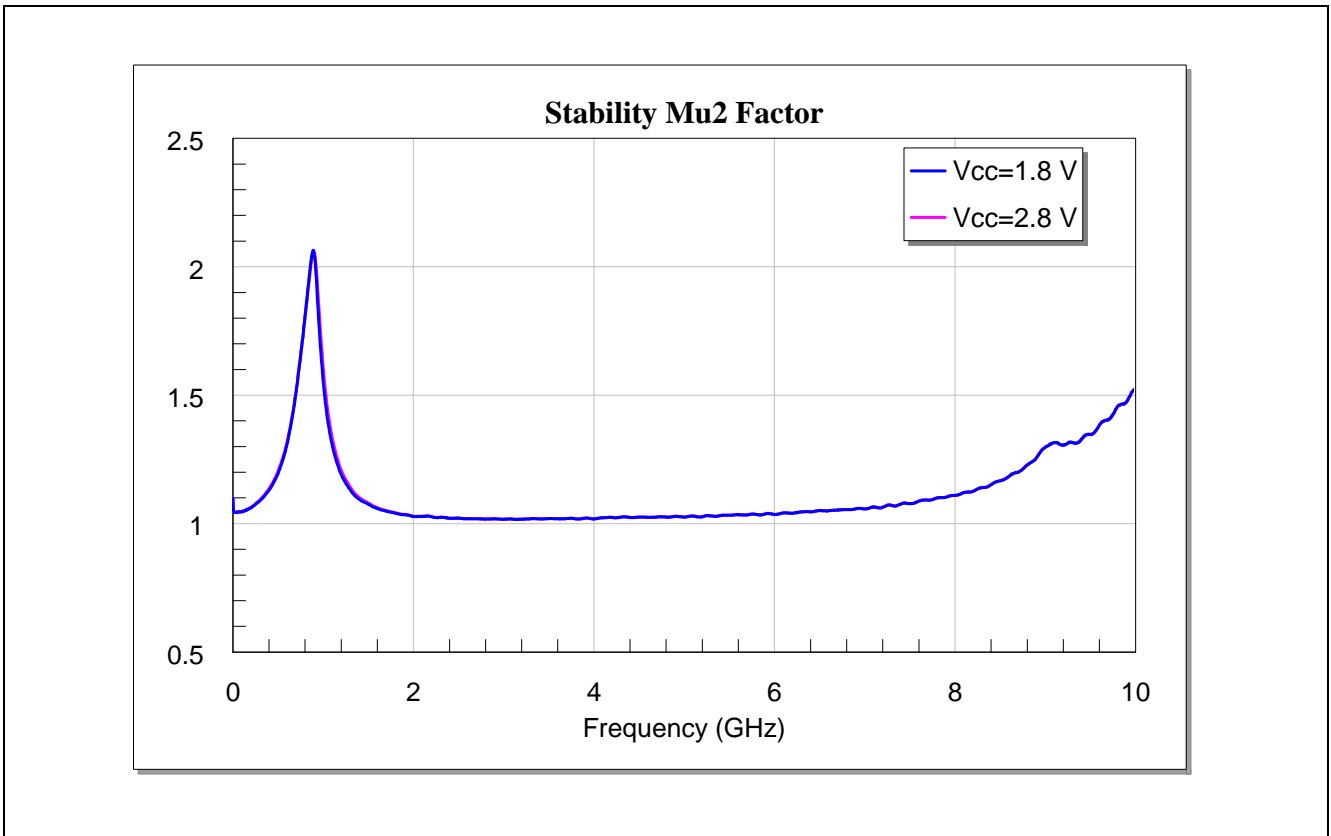

Figure 17 Stability Mu2-factor of the BGA7L1N6 for Band-5 Applications

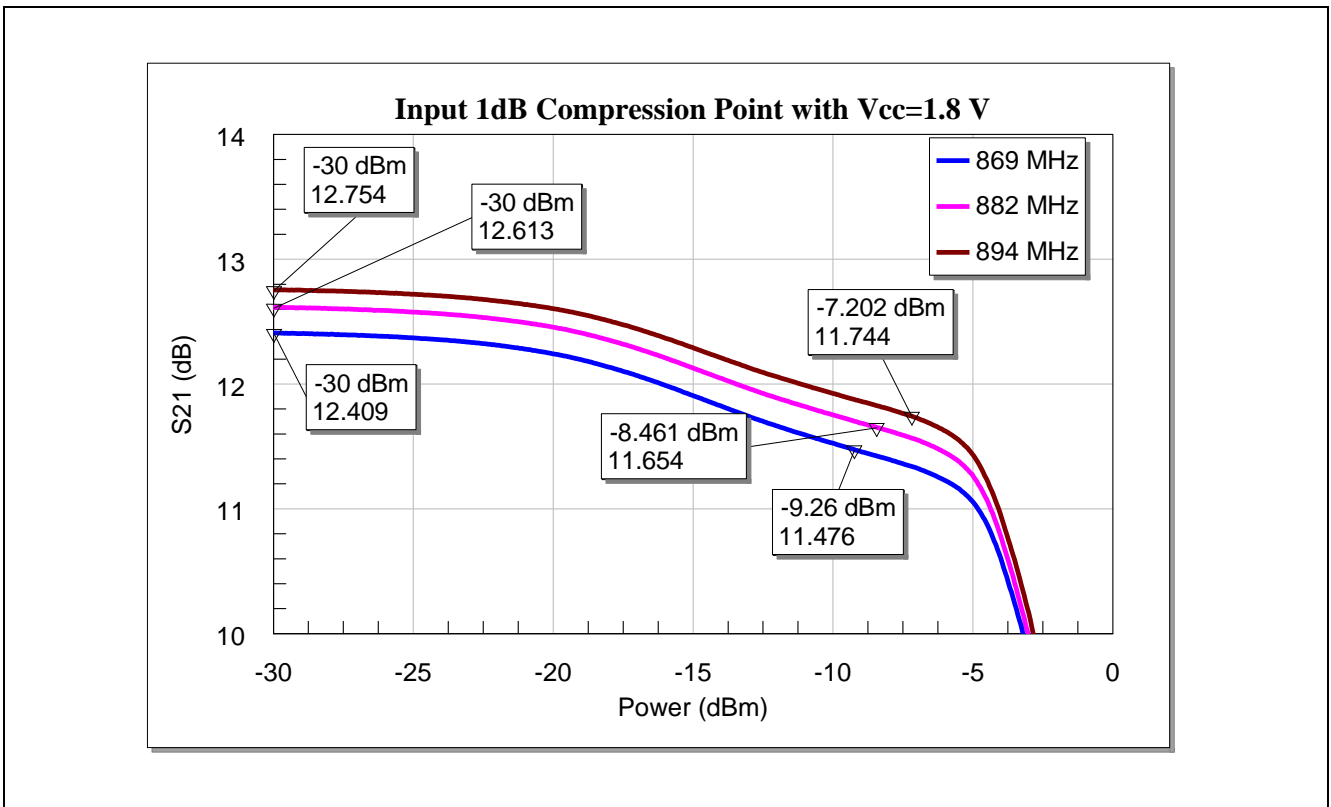

Figure 18 Input 1dB Compression Point of the BGA7L1N6 for Band-5 Applications with Vcc=1.8 V

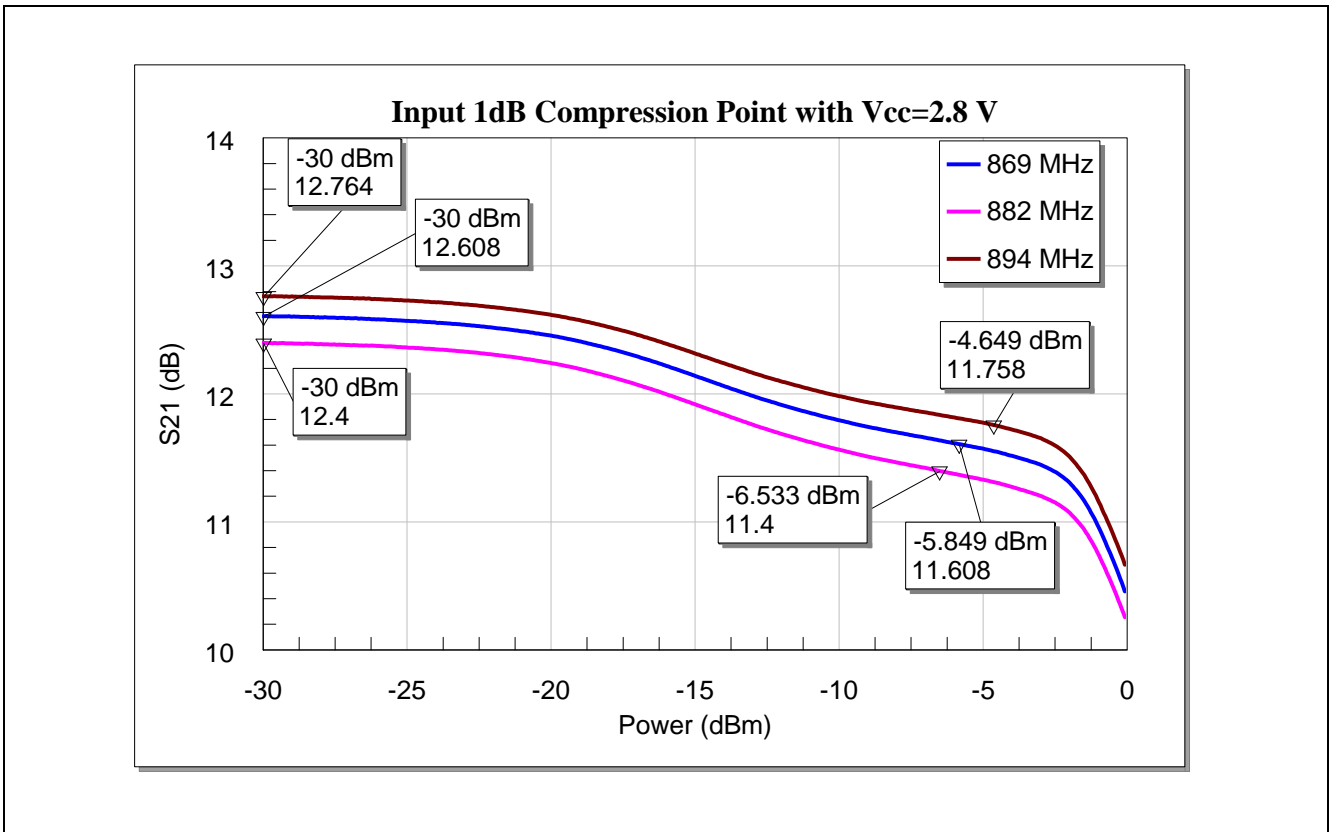

Figure 19 Input 1dB Compression Point of the BGA7L1N6 for Band-5 Applications with Vcc=2.8 V

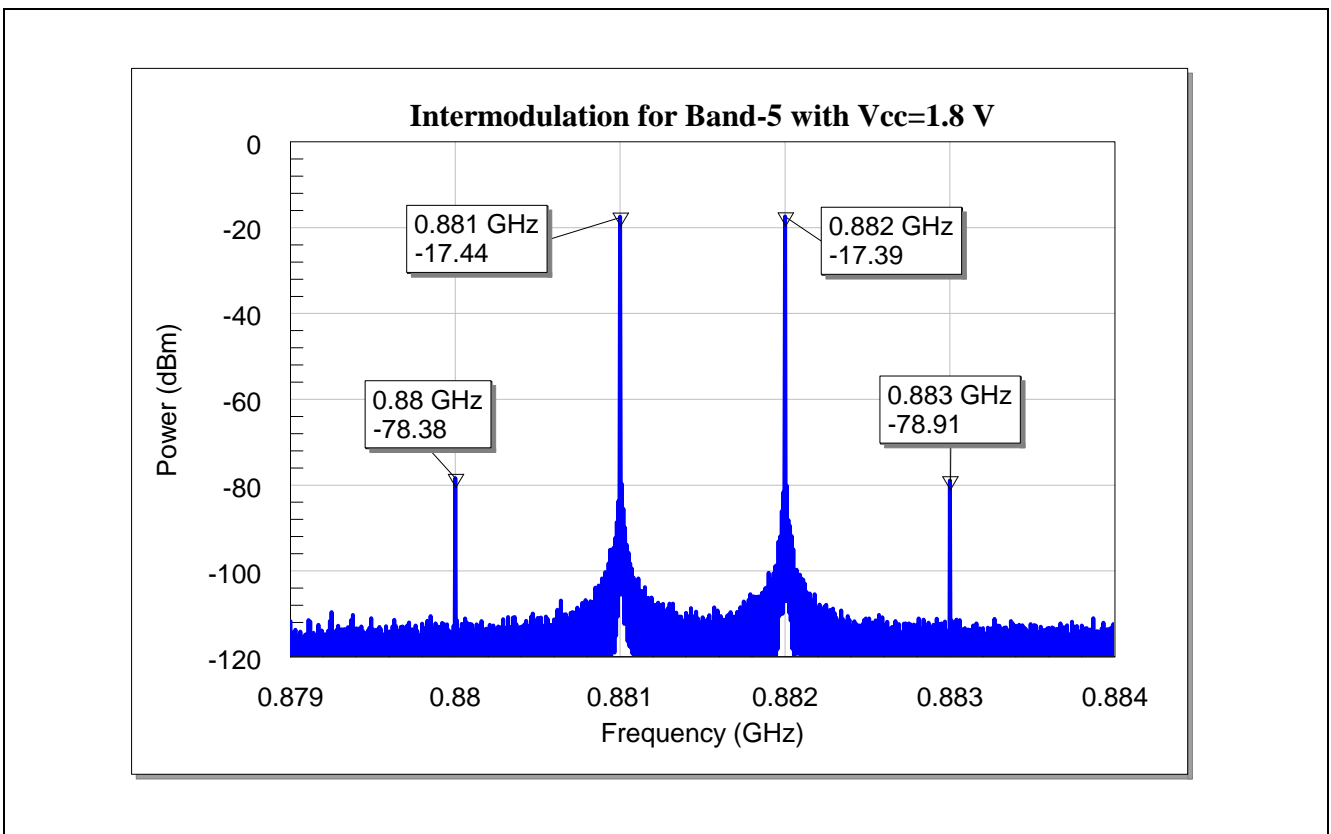

Figure 20 Input 3rd Intercept Point of the BGA7L1N6 for Band-5 Applications with Vcc=1.8 V

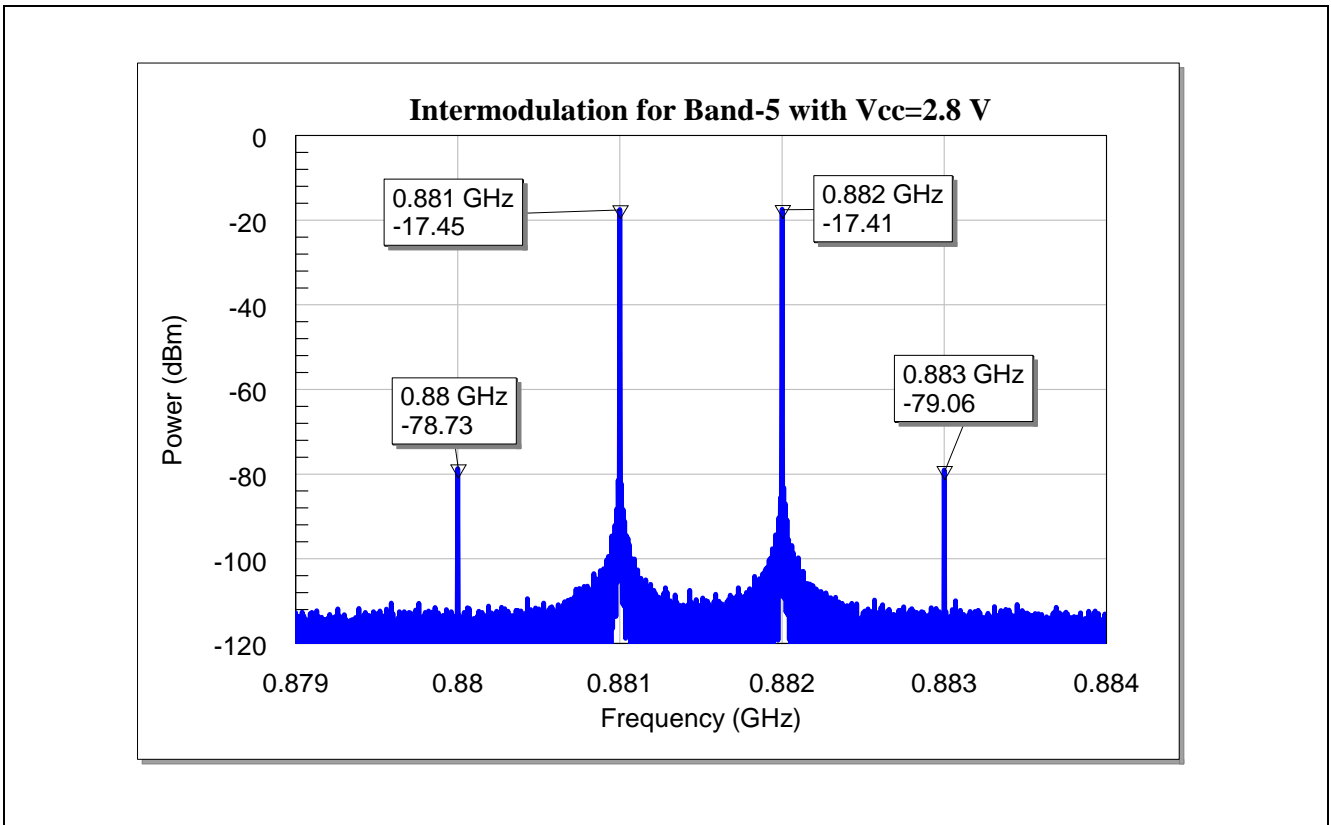

Figure 21 Input 3rd Intercept Point of the BGA7L1N6 for Band-5 Applications with Vcc=2.8 V

5 Evaluation Board and Layout Information

In this application note, the following PCB is used:

PCB Marking: BGA7x1N6 V1.0

PCB material: Ro4003

ϵ_r of PCB material: 3.4

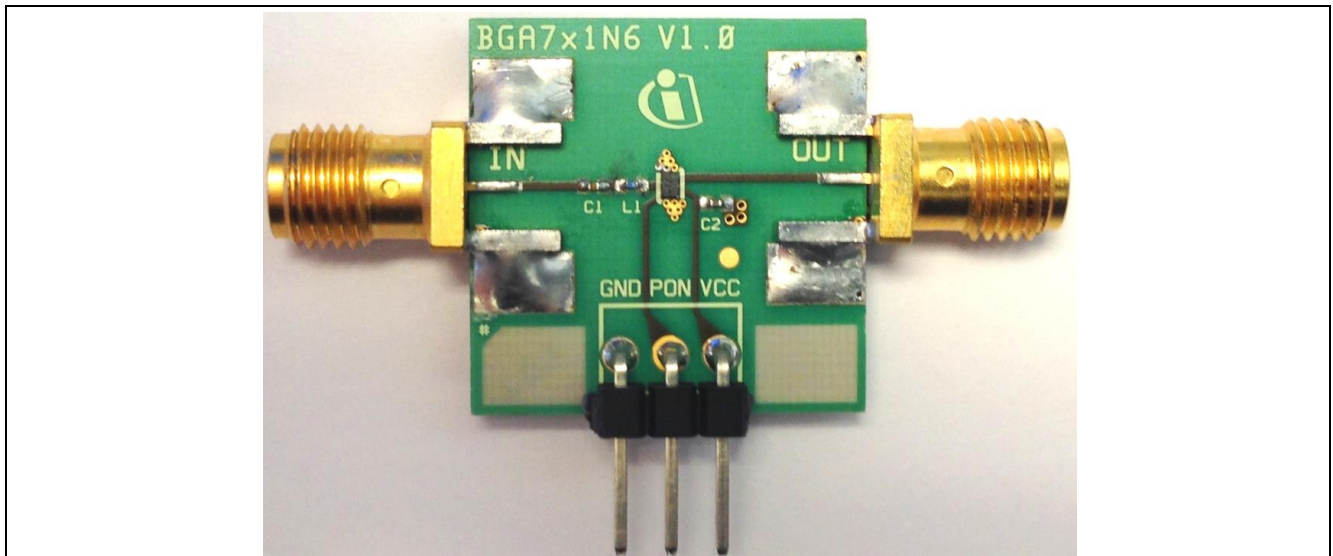

Figure 22 Picture of Evaluation Board (overview) , BGA7L1N6 V1.0

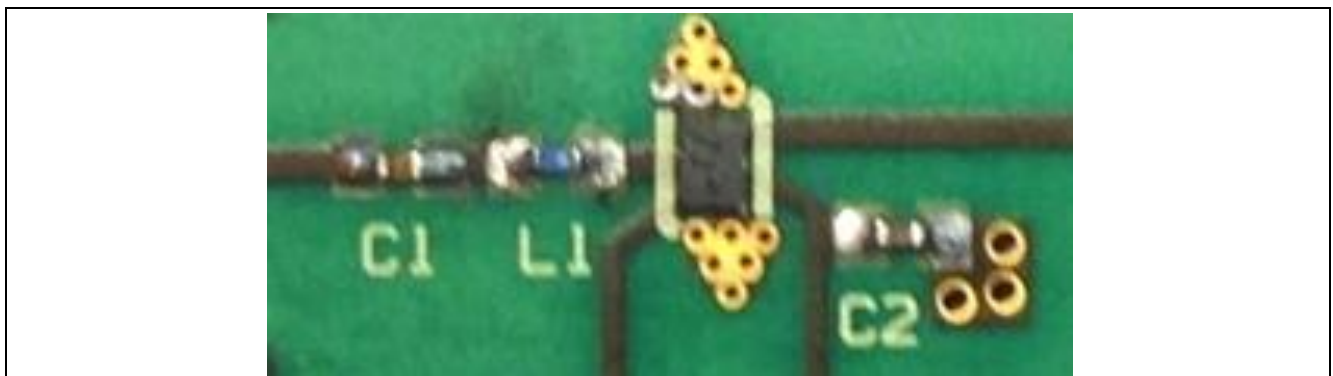

Figure 23 Picture of Evaluation Board (detailed view)

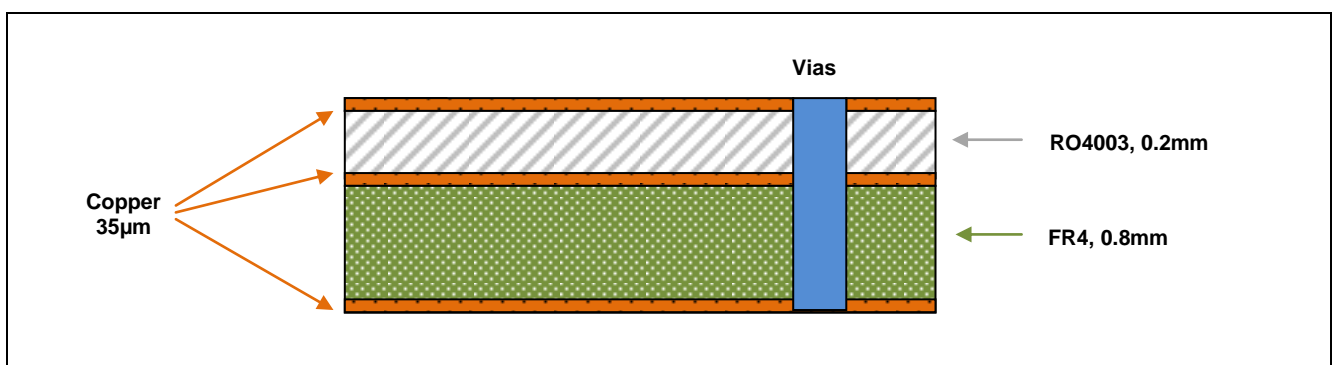

Figure 24 PCB Layer Stack

6 Authors

Moakhhkrul Islam, RF Application Engineer of Business Unit “RF and Protection Devices”
Dr. Fang Jie, RF Application Engineer of Business Unit “RF and Protection Devices”

7 Remark

The graphs are generated with the simulation software AWR Microwave Office®.

www.infineon.com