

Accurate Current Sensing in High Voltage Motor Drives

By Andrea Merello,
 International Rectifier

INTRODUCTION

Current sensing topologies vary according to many driving factors. In the appliance market, for example, the cost factor is dominant, while for the industrial market, performance is usually a key factor. Moreover, current levels discriminate between shunt-based current sensing that is often limited by the shunt thermal dissipation, and Hall-effect topologies. The IR2x77 and IR2x771 linear current sensor families are suitable for shunt-based topologies, providing accurate current sensing in a very compact SOIC16 wide (10.5x10.65 mm²) package.

Current is sensed directly in the phase at the shunt terminals. Noise cancellation and PWM ripple rejection are obtained as a result of a patented signal processing technique that allows a clean current signal to be generated and referenced to ground. Both PWM and analog output are available.

UP TO 1200V PHASE CURRENT SENSING

Figure 1 shows the typical connection of the IR2x77 high voltage current sensing IC. Excluding the shunt resistor, these IC families require only six components to be fully functional. In addition, the SOIC16wb package is noticeably smaller than typical Hall-effect sensor packages, enabling consistently reduced PCB area. A typical 1mA quiescent current allows a bootstrap technique to be used to supply the high voltage side. In most cases, the same high voltage supply can be shared with the gate driver supply as the IR2x77 and IR2x771 20V are supply compatible.

Being placed at phase voltage, the device is capable of withstanding voltages as high as 600Vdc or 1200Vdc. The elevated common mode rejection ratio allows sensing as low as $\pm 250\text{mV}$ on the shunt terminals for linear operation. A noise immune bi-directional level shifting circuit is used to avoid false common mode dV/dt noise up to 50V/ns. The analog output is proportional to the input current and is ratiometric within an upper and lower limit that can be set respectively by VRH and VRL pins. For this

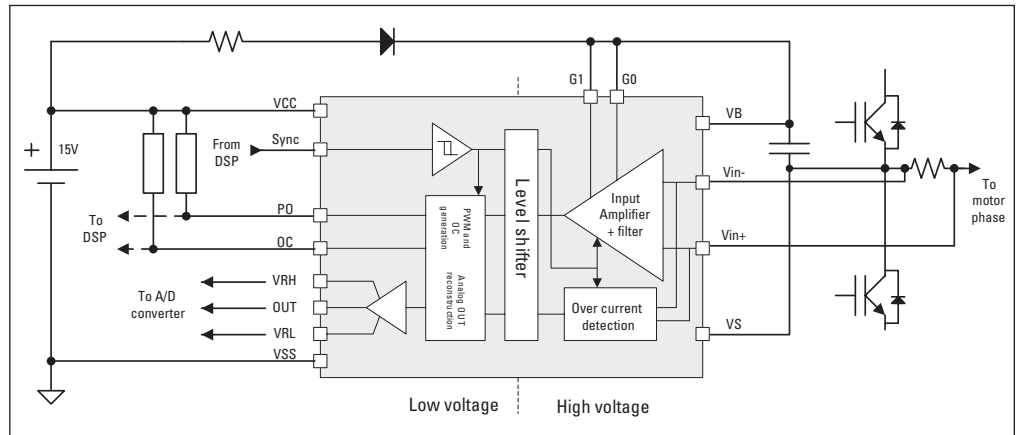

Figure 1: IR2277 high voltage current sensing IC typical application.

reason, it complies with most commercial A/D converters' input range. This feature is particularly useful when using different supplies for controller and other analog circuits, thereby solving the problem of level shifting the sensor output. The PWM output is also provided to enable better noise immunity in switching environments. In addition, a fast over-current comparator provides immediate feedback in case of excessive phase current.

ADVANCED SIGNAL FILTERING CAPABILITY

These advanced current sensing ICs internally convert the small differential voltage ($\pm 250\text{mV}$) developed across the shunt resistor into a time interval. This time interval is then converted into a PWM output that is synchronous with the PWM frequency of the power stage. As mentioned earlier, an analog output voltage is also provided. For both cases, the maximum throughput is 40k samples/sec suitable for up to 20kHz asymmetrical PWM modulation, and maximum delay is $< 7.5\mu\text{sec}$ (@20kHz).

Figure 2 shows the four stages that process the input signal. The first two stages perform the filtering action while the third and fourth stages generate PWM output signal and provide analog reconstruction to interface with the torque control loop of the MCU or DSP.

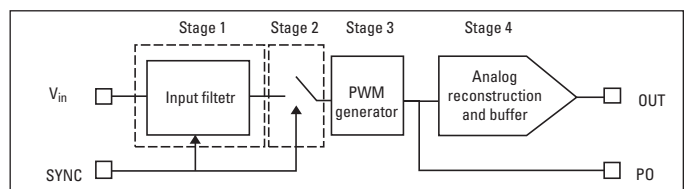

Figure 2: Signal processing path.

ACCURATE CURRENT SENSING IN HIGH VOLTAGE MOTOR DRIVES

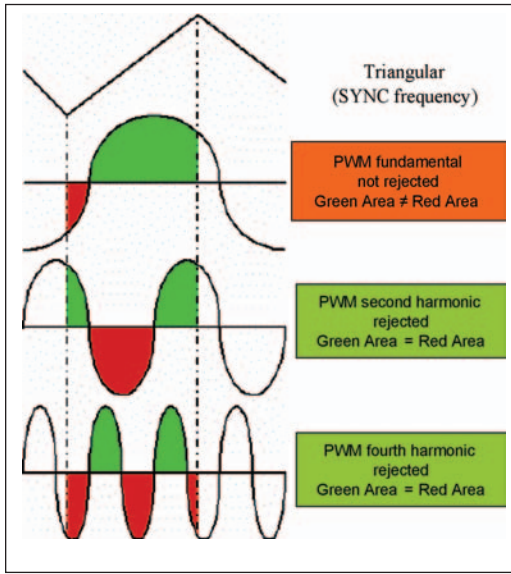

Figure 3: Even harmonic cancellation principle.

Traditional current sensing solutions are based on sensors with a signal bandwidth in the range of 100kHz. Such bandwidth allows high frequency noise to come into the sense path. Solutions to overcome this issue vary from a low cost RC input filter to more complex and expensive filtering techniques such as analog or digital post processing. In many cases, the final result is affected by a compromise between a large group delay or residual high frequency harmonics. The IR2x77 and IR2x771 input filter integrates a self-adaptive filtering action that is a function of the PWM switching frequency. The first stage is a re-settable integrator (Figure 3) that is synchronized with the PWM. The PWM frequency information must be provided with a 50% square wave signal to the sync pin. The synchronization allows the adaptive filter to put transmission zeros at the even harmonics of the input signal. This operation results in both high noise attenuation and in great phase lag compensation due to the beneficial action of the zeros. Moreover, the integral on one-half PWM period has a transfer function that is similar to a single pole system with cut frequency equal to PWM frequency (Figure 4 shows first stage transfer function for PWM switching frequency equals 10kHz) so that high frequency noise is rejected with -20dB/decade attenuation. The second stage samples the result of the first stage at double sync frequency. This action fully removes the odd harmonics from the input signal (Figure 5) without adding further delays.

The third stage provides the PWM output with a duty cycle proportional to the shunt voltage while the fourth stage reconstructs the ratiometric analog output that is updated once per one-half PWM cycle. Output is kept stable up to 70% of the one-half switching cycle, greatly relieving sampling related issues.

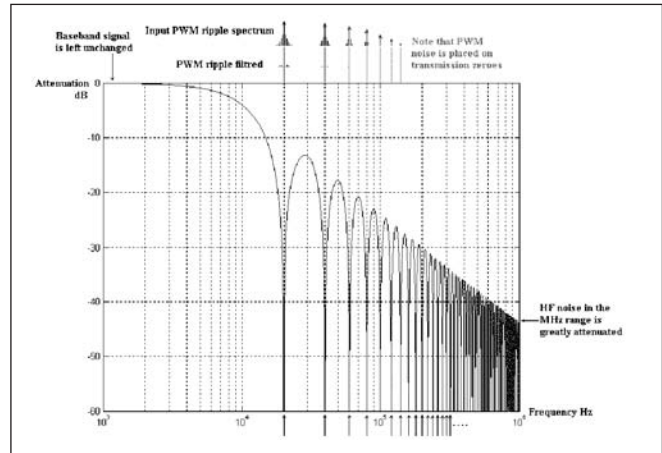

Figure 4: First stage transfer function (PWM switching frequency = 10kHz).

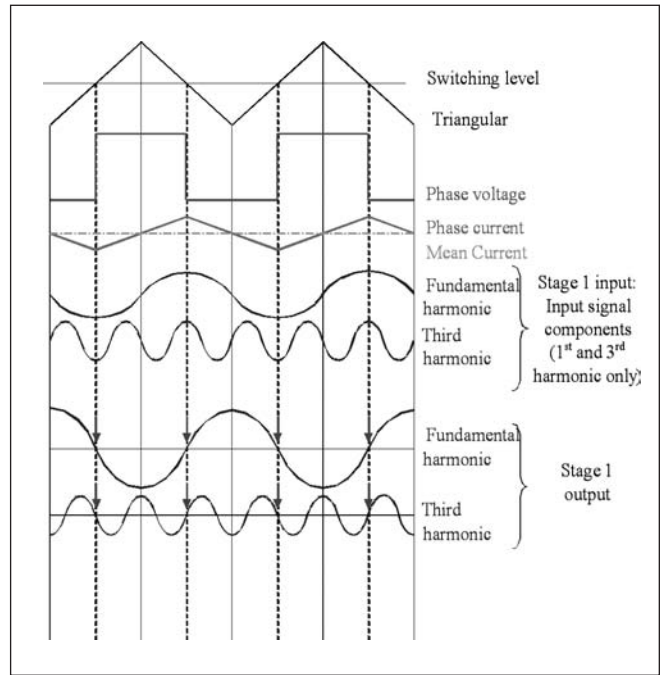

Figure 5: Odd harmonic cancellation principle.

CONCLUSION

The IR2x77 and IR2x771 current sense families are best suited to motor drives in light industrial and appliance designs where a phase shunt resistor technique is used for current sensing. Moreover, advanced filtering capability as well as an SOIC16wb package, bootstrap supply capability and the need of just six external components make these integrated circuits suitable for any motor drive application.

IRCS2277S Reference Design Kits are also available at www.irf.com.