

TLE 4209G

DC Motor Driver for Servo Applications



THE TLE 4209G is a protected H-Bridge Driver designed specifically for automotive manual headlight beam control and industrial servo control applications with DC-brush motor loads.

The part is built using the bipolar high voltage power technology DOPL.

The standard enhanced power PG-DSO-14-23 package meets the application requirements and saves PCB-board space and costs. The package is RoHS compliant.

The servo-loop-parameter pos.- and neg. Hysteresis, pos.- and neg. deadband and angle-amplification are programmable with external resistors.

An internal window-comparator controls the input line. In the case of a fault condition, like short circuit to GND, short circuit to supply-voltage, and broken wire, the TLE 4209G stops the motor immediately (brake condition).

Furthermore the built in features like over- and under voltage-lockout, short-circuit-protection and over-temperature-protection will open a wide range of automotive- and industrial applications.

Applications

- Manual Headlight Beam Control
- Servo Control Applications for Industrial and Automotive Market

Features

- Optimized for manual headlight beam control applications
- Delivers up to 0.7 A continuous
- Low saturation voltage; typ. 1.6 V total @ 25 °C; 0.7 A
- Output protected against short circuit
- Over temperature protection with hysteresis
- Over- and under voltage lockout
- Internal clamp diodes
- Enhanced SMD power package
- Green Product (RoHS compliant)
- AEC Qualified

www.infineon.com/DC-Motor-Bridges

Automotive Power



Never stop thinking

Block Diagram

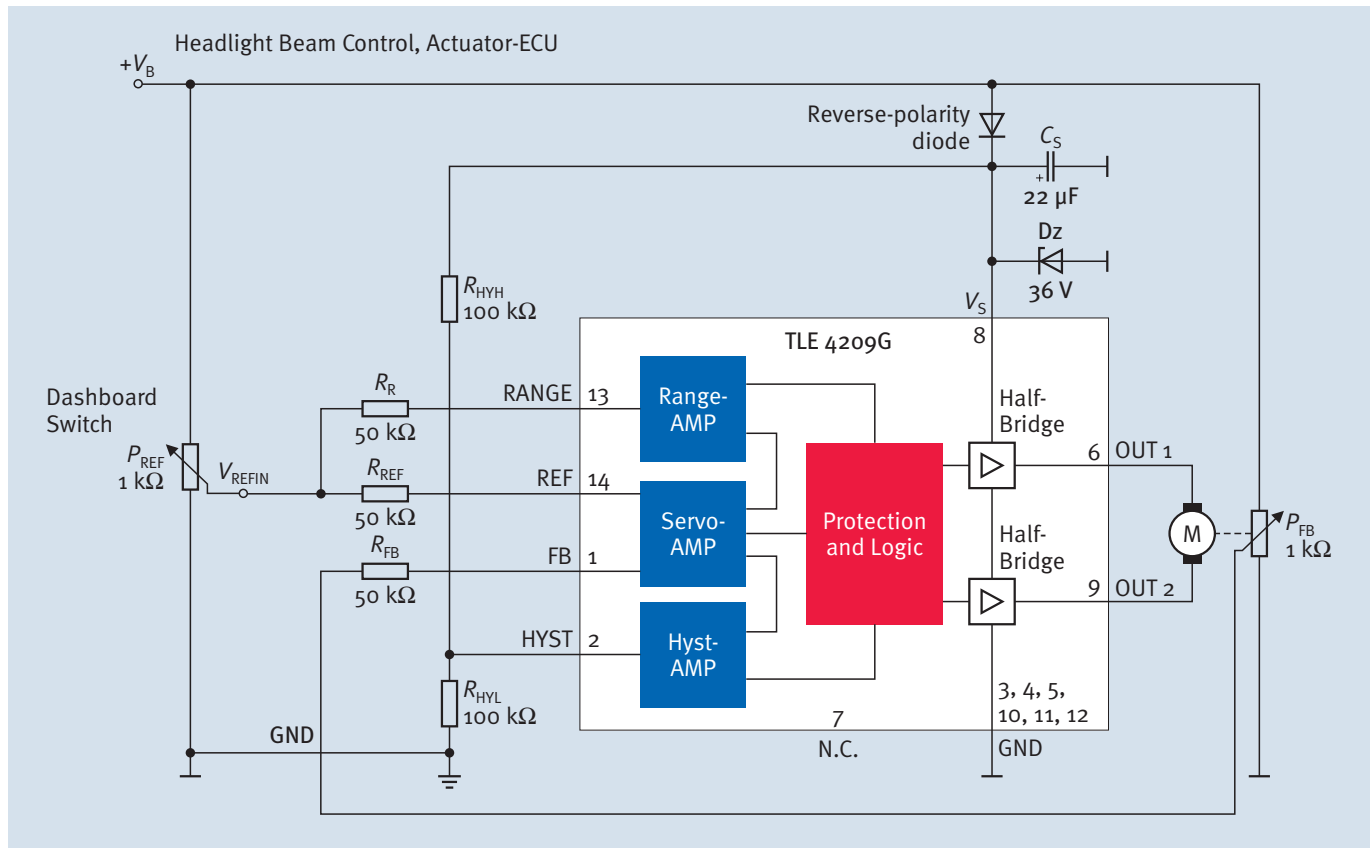

Examples for further Infineon Headlight Application Products

Type	Description	Package
TLE 4209A	Servo driver for manual headlight beam control	PG-DIP-8
TLE 4206G	Servo driver for manual headlight beam control with current peak blank	PG-DSO-14
TLE 4206-2G	Servo driver for automatic static headlight beam control	PG-DSO-14
TLE 4729G	Stepper motor driver for automatic headlight beam control	P-DSO-24
TLE 4205G	Servo driver for truck applications	P-DSO-20
BTS 6142D	High-side switch for headlight (55 ... 65 W)	P-TO252-5
BTS 6143D	High-side switch for headlight (55 ... 65 W)	P-TO252-5
BTS 5236-2GS ¹⁾	High-side switch for side indicators (2 x 27 W)	PG-DSO-14
BTS 5231-2GS ¹⁾	High-side switch for park light (2 x 10 W)	PG-DSO-14
BTS 5590G ²⁾	SPI Power controller for advanced light control	PG-DSO-36
µC XC866	8-bit Microcontroller for headlight control unit	PG-TSSOP-38

1) Available in Q4 2007

2) Available in Q3 2007

How to reach us:
<http://www.infineon.com>

Published by
 Infineon Technologies AG
 81726 Munich, Germany

© 2007 Infineon Technologies AG
 All Rights Reserved.

Legal Disclaimer

The information given in this Product Brief shall in no event be regarded as a guarantee of conditions or characteristics. With respect to any examples or hints given herein, any typical values stated herein and/or any information regarding the application of the device, Infineon Technologies hereby disclaims any and all warranties and liabilities of any kind, including without limitation, warranties of non-infringement of intellectual property rights of any third party.

Information

For further information on technology, delivery terms and conditions and prices, please contact the nearest Infineon Technologies Office (www.infineon.com).

Warnings

Due to technical requirements, components may contain dangerous substances. For information on the types in question, please contact the nearest Infineon Technologies Office.

Infineon Technologies components may be used in life-support devices or systems only with the express written approval of Infineon Technologies, if a failure of such components can reasonably be expected to cause the failure of that life-support device or system or to affect the safety or effectiveness of that device or system. Life support devices or systems are intended to be implanted in the human body or to support and/or maintain and sustain and/or protect human life. If they fail, it is reasonable to assume that the health of the user or other persons may be endangered.