

# A New Low-Cost Flexible IGBT Inverter Power Module for Appliance Applications

Mario Battello, Neeraj Keskar, Peter Wood, Mor Hezi, Alberto Guerra  
International Rectifier Appliance & Consumer Group, El Segundo CA

*as presented at PCIM China, March 2003*

**Abstract-** Power modules for inverterized motor drive applications are a current trend due to the advantages they present like space saving and ease of assembly. However, their widespread use is limited due to cost issues and relative design inflexibility. A novel low-cost intelligent power module (IPM) series has been developed for appliance applications, which addresses these factors. Characteristics of the new intelligent power module enable lower overall power losses compared to current competing technology. Significant improvement in the EMI performance of the system has been obtained despite faster dynamic switching through use of special packaging techniques. These traits are clearly demonstrated by performing in-depth evaluations in an actual home air conditioning application.

## I. INTRODUCTION

The electronics industry is in a "high-density mounting" period in which progress is being made at phenomenal rates. In order to obtain high power density, the IR Plug N Drive power modules represent a sophisticated, integrated solution. It enables the integration of 3 phase motor drives used in a variety of appliances, such as washing machines, energy efficient refrigerators and air conditioning compressor drives up to 2KW. The modules utilize non-punch-through (NPT), IGBT technology matched with hyperfast diodes, while to minimize EMI generation. In addition to the IGBT power switches, the modules contain a 6-output monolithic gate driver chip, matched to the drive requirements of the IGBTs to generate the most efficient power switch consistent with minimum noise generation and maximum ruggedness. All these components are mounted on Insulated Metal Substrate (IMS).

Insulated Metal Substrate Technology (IMST), which originally was developed as a low cost method for mounting bare chips, has evolved into an excellent technology for achieving high performance and high reliability in high-density solutions. The IMST substrate uses an aluminum plate as the base. The upper side of the substrate forms a sandwich of a high voltage dielectric and a copper cladding on which the circuit is etched, similar to a conventional printed wiring board. This allows the creation of hybrid ICs that take advantage of two primary features of the aluminum substrate, namely high thermal conductivity and simple machining.

## II. SYSTEM DESCRIPTION

The 600V Plug N Drive module contains six IGBT dies each with its own discrete gate resistor, six commutation diode dies, one three-phase monolithic, level shifting driver chip, three bootstrap diodes with a current limiting resistor and an NTC thermistor /resistor pair for over-temperature protection. The over current trip circuit also responds to an input signal generated from an external sense element such as a current transformer or sense resistor. The input pin for the trip circuit performs a dual function as an input pin for over current trip voltage and an output pin for the module analog temperature sensing thermistor. The module schematic shown below includes the values of the thermistor and its associated components to facilitate the design of external circuitry. A small resistor is included in the bootstrap circuit to limit peak currents in the bootstrap diodes especially when using large value bootstrap capacitors, which are necessary under certain operating conditions. The power module integrates the driver and the power stages into an isolated module but the 'brains' of the system must generate timing, speed and direction PWM or PFM information to complete the motor drive function. 5-volt logic systems are generally preferred from a noise immunity standpoint but the module can also accept 3.3V logic or any signal level up to Vcc (+15V). The IR 21365 monolithic driver IC inputs have pull-up resistors to the internal 5V reference and require a logic low to command an output. The pull-down current is 300 $\mu$ A maximum. The Itrip input is 4.3V nominal and the under voltage lockout voltage is 11V. Further information on IR21365 characteristics is available at [www.irf.com](http://www.irf.com).

## III. SWITCHING PERFORMANCE AND ENERGY LOSSES

The non-punch through (NPT) IGBTs and hyperfast diodes used in the IR Plug N Drive power modules are designed for fast switching without excessive ringing. Competing modules built on punch-through (PT) technology were also evaluated in the application and their performance compared with the IR power module.

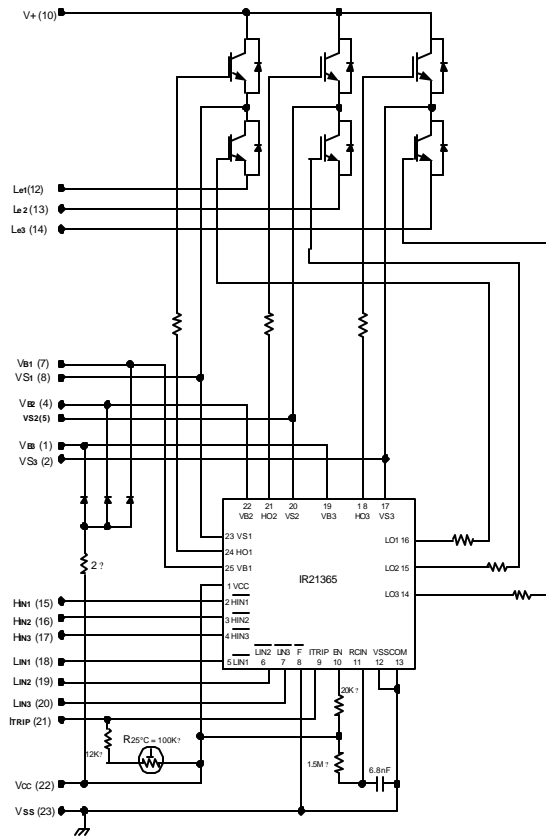

IR Plug N Drive module schematic

In order to improve the EMI performance of the system, the competitor's module uses slower IGBTs with switching times around 1  $\mu$ s. The higher switch losses resulting from slower switching are offset by the lower conduction losses of the PT process.

A comparison of the turn-on and turn-off switching waveforms is shown in figures 1a and 1b. It is apparent that both turn-on and turn-off di/dt rates are higher for the IR module. The competitor's module also shows higher tail current during turn-off, typical of PT IGBTs.

A chart indicating the variation of switching dV/dt rates with switching current is shown in figure 2. While turn-on dV/dt is similar in both devices, the turn-off dV/dt is much lower in the competitor's device (1.63 V/ns for competition Vs 6.38 V/ns for IR part at 5 A,  $T_J=25^\circ\text{C}$ ).

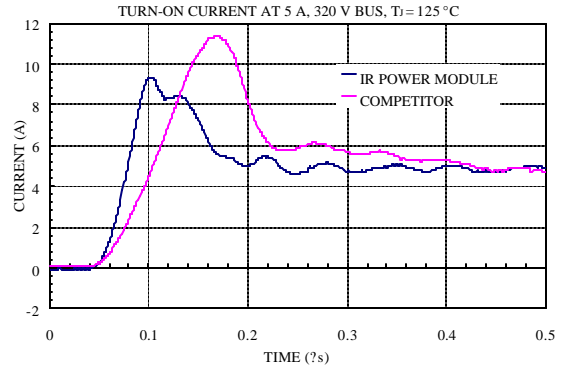

Figure 1(a) Switching current waveforms at 300 V, 5 A,  $T_J = 125^\circ\text{C}$  at IGBT turn-on

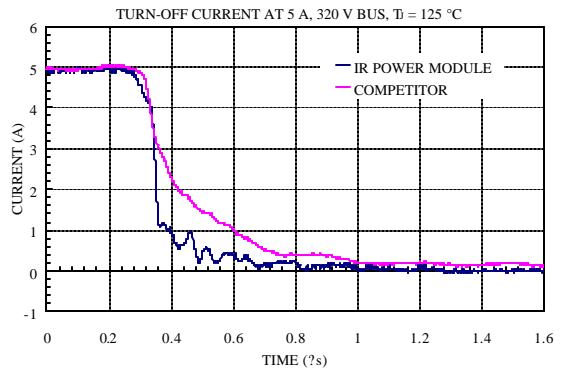

Figure 1(b) Switching current waveforms at 300 V, 5 A,  $T_J = 125^\circ\text{C}$  at IGBT turn-off

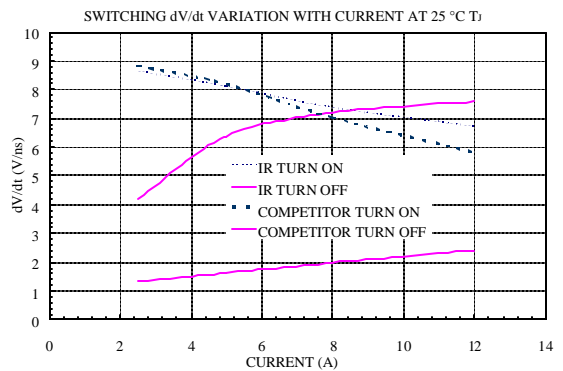

Figure 2. Switching dV/dt at 300 V, 5 A,  $T_J = 25^\circ\text{C}$

Switching energy comparisons are shown in figure 3.

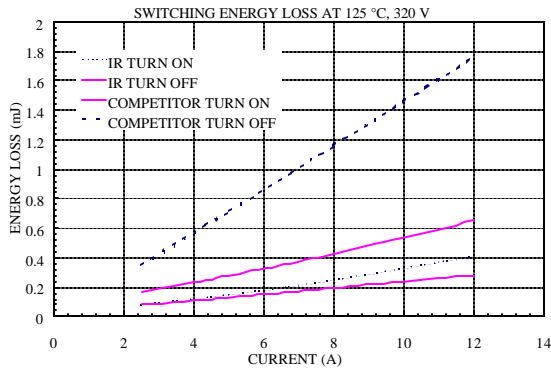

Figure 3. Switching energy at 300 V, 5 A,  $T_J = 25\text{ }^\circ\text{C}$

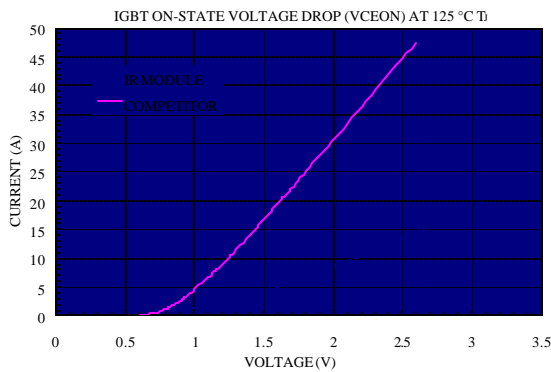

Figure 4. On-state voltage drop  $V_{CEON}$  at  $T_J = 125\text{ }^\circ\text{C}$

Forward conduction voltages ( $V_{CEON}$ ) are shown in figure 4. The competitor's part has a lower  $V_{CEON}$  than the IR part ( $\sim 1\text{ V}$  Vs  $1.6\text{ V}$  at  $5\text{ A}$ ,  $T_J=125\text{ }^\circ\text{C}$ ). Based on the above measurements and knowing the operating conditions, total module power losses in the air-conditioner under study were calculated. The procedure used for this calculation is briefly described below.

#### IV. POWER LOSS ESTIMATION METHODOLOGY

The complexity associated with making accurate physics-based models suggests that a more pragmatic approach could be used. This would involve measuring elemental energy losses and calculating total power losses using system level models. Switching losses for the IGBT and diode can be measured and modeled empirically as functions of voltage and current. Similarly on-state voltage drop can be represented as a function of current.

$$\begin{aligned} E_{ON} & \approx h_1 I^x + h_2 I^k \\ E_{OFF} & \approx m_1 I^y + m_2 I^n \\ V_{CEON} & \approx V_T + aI^b \end{aligned} \quad (1)$$

In the equations (1),  $V_T$  is the voltage drop across the IGBT/diode at zero current and  $h_1, h_2, x, k, m_1, m_2, y$  and  $n$  are empirical parameters obtained to get a good curve-fit between measured and calculated values.

Knowing the switching frequency in the application, the energy losses can be averaged per switching cycle giving power loss per switch cycle. Assuming that the current varies linearly within one switching cycle and the variation is small, the average current in the switching cycle can be assumed to be constant throughout the switching period. This is shown in figure 5. The value of this average switch current follows the output current waveform, e.g. a sine wave for sinusoidal current.

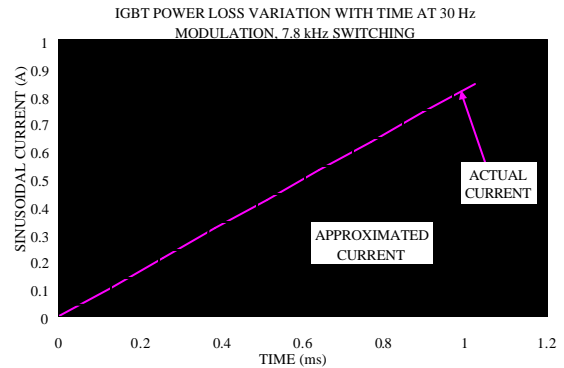

Figure 5. Current averaging for sinusoidal current

The switching energies at turn-on and turn-off, and the conduction drop can be calculated for each switching cycle using equations 1, and averaged giving a time-variant power loss as shown in figure 6. This figure shows power loss variation with a sinusoidal current for half a modulation cycle i.e. for one IGBT. Knowing this variation, the average power loss can be easily calculated per IGBT (or diode) and for a 3-phase inverter system.

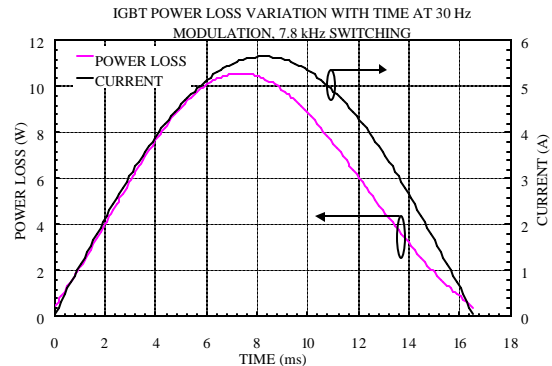

Figure 6. Average power loss variation in single IGBT/diode within half a period of sine cycle

## V. ESTIMATION OF POWER LOSSES IN AIR-CONDITIONER

Since the inverter power module in the air-conditioner under study was mounted on a forced-air cooled heat sink, temperature variation of the heat sink was very small with change in module power dissipation. Power losses were estimated using the methodology described earlier under the maximum compressor load conditions:  $V_{BUS} = 390V$ ,  $f_{sw} = 7.8kHz$ , motor current = 4A RMS (sinusoidal), PF=0.7, modulation index = 0.8 at junction temperatures of 25 °C and 125 °C. In the actual application, the junction temperature is estimated to be not more than 75 to 80 °C. So a number somewhere in the middle between the two estimated limits would represent the actual power losses.

Power loss variation with time under the conditions above and 30 Hz modulation frequency is shown in figures 7(a) and (b). The average power losses per IGBT and in the complete inverter are listed in Table 1(a) and (b). Note that total power losses include diode power losses. It is clearly seen that power losses are much lower in the IR part on account of the much faster switching speeds and consequently lower switching losses.

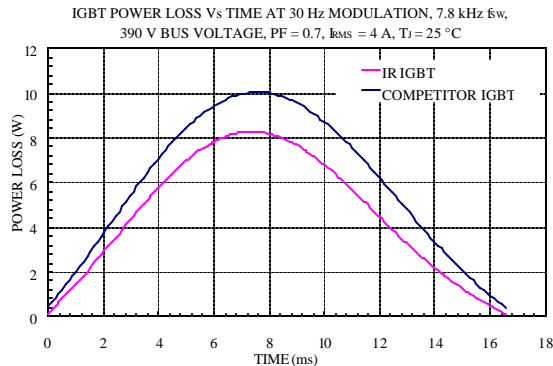

Figure 7(a). IGBT power loss at  $T_j = 25$  °C

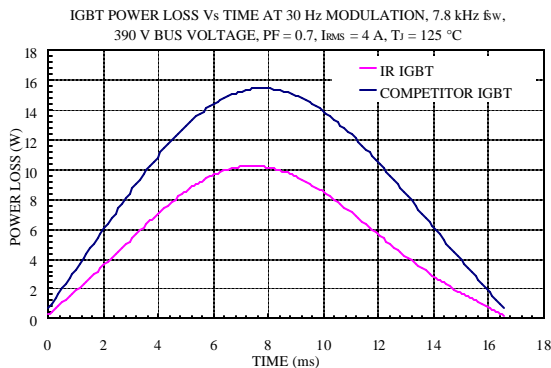

Figure 7(b). IGBT power loss at  $T_j = 125$  °C

Losses	IR	Competitor
IGBT conduction (W)	1.70	1.43
IGBT switching (W)	0.63	1.64
IGBT total (W)	2.33	3.07
Total inverter losses (W)	18.1	22.9

Table 1(a). Average power loss distribution at 25 °C

Losses	IR	Competitor
IGBT conduction (W)	1.89	1.31
IGBT switching (W)	1.02	3.47
IGBT total (W)	2.91	4.78
Total inverter losses (W)	21.3	34.0

Table 1(b). Average power loss distribution at 125 °C

The competitor's IGBT, as stated earlier, has lower conduction losses than the IR part. Because it is a PT device rated at 20A, the conduction losses are inversely proportional to temperature. On the other hand, for the IR NPT part, conduction losses increase with temperature. However, the significant difference is due to switching losses, especially at higher junction temperatures, where the competitor's part shows higher sensitivity than the IR part. Since the actual operating temperature is estimated to be not more than 75-80 °C, the total power losses would be about 27-28 W for the competitor's device compared with 19-20 W for the IR part.

## VI. EMI PERFORMANCE

Starting from the IMST structure mentioned earlier, the aluminum layer is also a good electrical conductor and it can be used, via wire bonding connection, as an internal ground layer becoming an Equipotential Ground Plane (EGP). It would work as ground plane but not as equipotential point for the power module internal circuitry.

The typical PCB boards in the appliance industry are, for cost reason, one or two layers. This forces the designer to implement single point grounding techniques. A single point ground connection is one in which several ground returns are tied to a single reference point. [1,2] The intent of this single point ground location is to prevent currents from the power section flowing to the logic ground section of the system via common current paths.

The grounding scheme commonly used in appliance applications is shown in figure 11. Distributed capacitance is also present among the circuitry and ground. When both inductance and capacitance are present, noise transients are generated by the ringing triggered by fast  $dV/dt$ 's in the circuit. High frequency loops must be kept as small as possible in order to reduce radiated RFI. Reducing the impedance in the high frequency loop by adding a

high frequency capacitor in parallel to the RF path greatly reduces RFI.

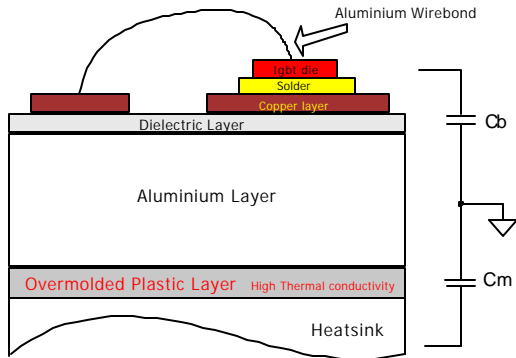

Figure 8 Physical power module structure IMST

The combination of the EGP and the positive input rail provides a distributed high frequency capacitor located inside the power module. It is connected in parallel with the bulk smoothing capacitors creating a low impedance path for the high frequency currents generated by the inverter. It also contributes to differential mode RFI attenuation reducing the conducted noise of the motor drive. The IGBT dies are mounted on the IMS substrate with the high side emitter and the low side collector forming a switching node. This node switches the DC bus voltage and is the source of the generated wide band RFI. The equivalent capacitor from this node to the ground plane,  $C_b$  is shown in figure 8. This capacitor conducts both differential and common mode noise.

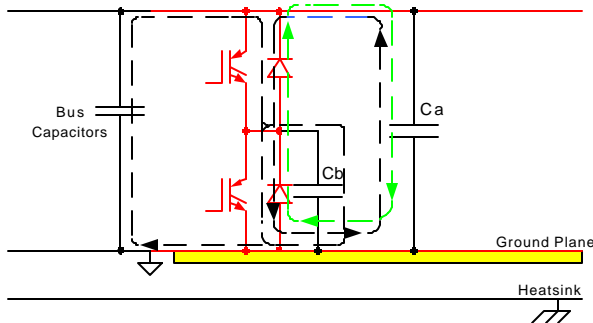

Figure 9. Differential mode noise path in the Plug N Drive module

For differential mode noise  $C_b$  plays an important role. It acts as a snubber network for the turn-on and turn-off transients, to reduce the radiated noise. The distributed high frequency bus capacitor located inside the power module is denoted by  $C_a$ . It reduces the high frequency loop size thus confining the RF currents very close to the noise source. Figure 9 shows the differential mode scenario relating to a single inverter leg.

Common mode noise is injected into the heat sink via the distributed circuit capacitances between the heat sink and the input rail. In some cases, the heat sink is grounded to the equipment enclosure and this path forms the connection to inject common mode noise. If the metal substrate is connected to the DC return bus instead of being grounded or floating, it improves the attenuation of common mode noise by shielding the source. The common mode paths are represented by the  $C_m$  capacitors shown in figure 10. The dashed lines indicate the common mode current paths.

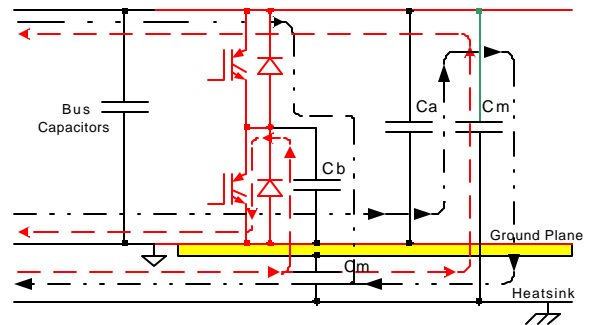

Figure 10. Common mode noise path in the Plug N Drive module.

The new IR Plug N Drive module was tested in a variable speed compressor drive to verify the hypothesis made for the IMST structure. The equipment under test is a commercial 1.4kW split system air-conditioner, operating from 230V, 50/60Hz mains. The original unit used an established competitor's three-phase IGBT module with PT technology. This paper shows the EMI test comparisons between the competitor's module and the IR Plug N Drive module. Our tests compared IR modules with and without the ground plane connection to verify the effectiveness of this technique.

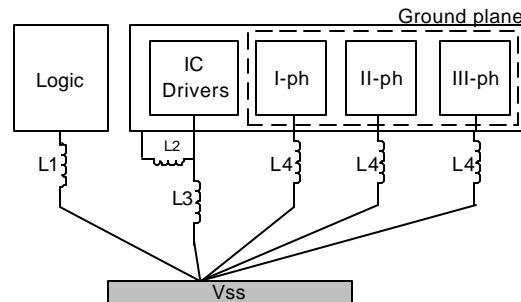

Figure 11. Single point Parallel ground connections

The EMI tests were made as described in specification [4] EN55014 "Requirements for household appliances electric tools and similar apparatus". Conducted EMI measurements made

with and without the built in passive input pi filter. Figure 12 shows the performance of the IR module with and without the aluminum substrate grounded, and the competitor's module originally used in the system. The advantage of the ground plane connection is shown in Fig. 12. In spite of its faster switching, the noise generated by the IR part is about 5dB $\mu$ V lower than the original competitors module in the < 1MHz range. It is also noted that Figure 12 shows the results without the input EMI filter at maximum compressor speed. That is the worst-case scenario as far as EMI generation is concerned. The IR module produces lower noise than the competitor's part because of the ground plane connection. This confirms our original assumptions.

Air conditioners rarely work continuously at maximum speed so in order to provide a more realistic comparison, the input EMI filter was re-connected and additional tests were performed at average compressor speed. Figure 13 shows the conducted noise performance with the system in the original configuration. From Figure 13 it is apparent that the aluminum plate lowers noise in the differential mode, up to 1 MHz, and partially in the common mode up to 5MHz. Notice that the IR part shows higher EMI improvement below 5MHz because the substrate grounding is more effective at lower frequency.

## VII. CONCLUSION

New high quality Plug N Drive modules have been developed for home appliance applications, using six NPT 600V IGBT dies, six free wheeling diode dies, one three-phase monolithic, level shifting driver chip, three bootstrap diodes with current limiting resistors and an NTC thermistor. All the parts have been selected for low cost coupled with high performance for the appliance market. The performance in an actual application shows lower overall power losses compared with competitive technology even at higher switching speed, which yields better efficiency. Despite the higher dV/dt superior conducted EMI performance was demonstrated using the ground plane integrated within the structure of the power module. It is to note that the dies used in the PlugNDrive module were smaller than the ones used in the competitor's counter part, allowing achieving even lower costs, while maintaining superior performance. In summary, the Plug N Drive module solution provides a viable replacement alternative for appliance motor drives and other light industrial drive applications.

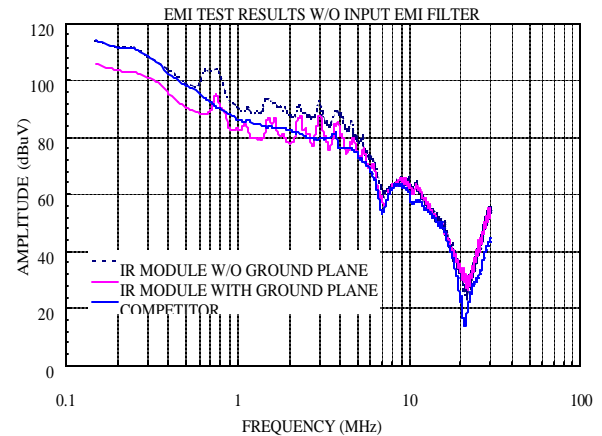

Figure 12 Conducted EMI in the A/C application with input EMI filter disconnected

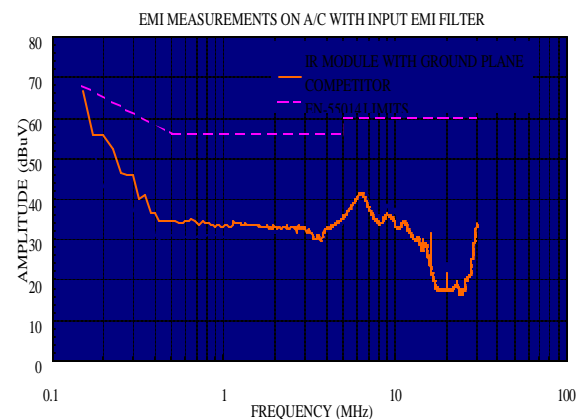

Figure 13 Conducted EMI in the A/C application with the input EMI filter connected

## VIII. REFERENCES

- [1] Mark I. Montrose, "EMC and the Printed Circuit Board", IEEE Press, 2000, pp 247-279.
- [2] Clayton R.Paul, "Electromagnetic Compatibility", , Hoepli, 1995, pp 645-678.
- [3] IR Application Note, AN1044 "Plug N Drive family Applications overview", 2002.
- [4] The European Standard EN 55014-1:2000 has the status of a British Standard, Electromagnetic compatibility "Requirements for household appliances, electric tools and similar apparatus", October 2000.