

Reduce Power Dissipation in UPS, Welding and Solar Inverter Applications

FEATURES & BENEFITS

- Lower conduction and switching losses compared to previous generation IGBTs.
- 175°C maximum junction temperature.
- Square Reverse Bias Operating Area (RBSOA).
- 100% tested for clamped inductive load.
- Increased current density from the same package.
- Positive $V_{CE(ON)}$ temperature co-efficient

600V Trench Field Stop IGBTs

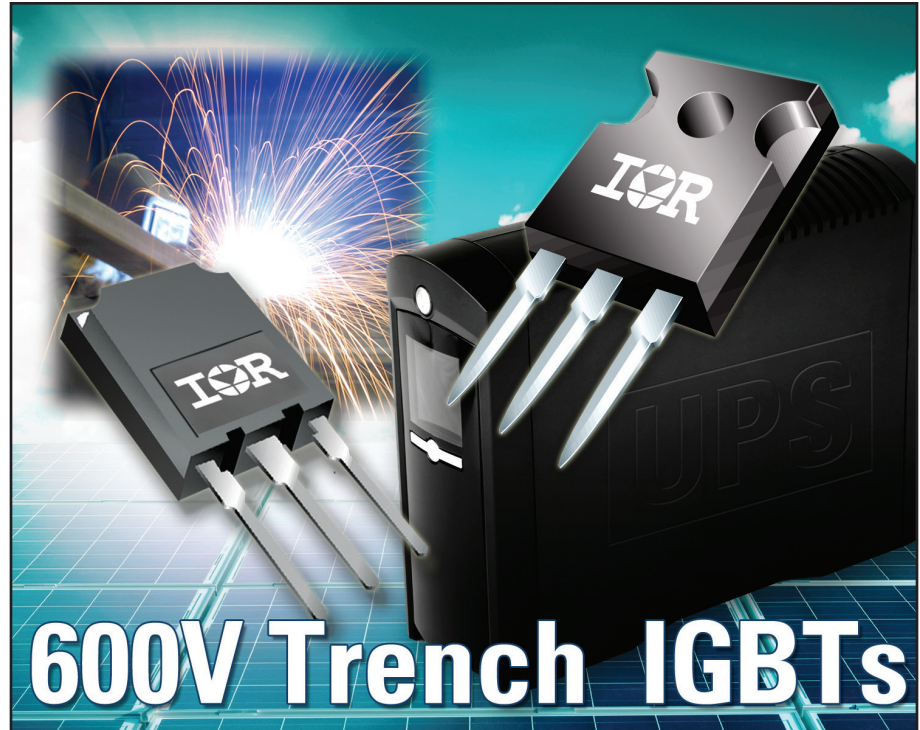

International Rectifier's family of 600V insulated gate bipolar transistors (IGBTs) reduces power dissipation in uninterruptible power supply (UPS), welding, and solar inverter applications up to 20 kW.

These devices use IR's latest-generation field stop trench technology to reduce conduction and switching losses, and are optimized for switching between 8-30 kHz with short circuit requirements, enabling higher efficiency power conversion in UPS, welding and solar inverter applications. Additionally these devices exhibit a positive $V_{CE(ON)}$ temperature co-efficient, which allows for easy paralleling of multiple IGBTs.

Co-packaged with ultrafast soft recovery diodes, this family of IGBTs has lower collector-to-emitter saturation voltage ($V_{CE(on)}$) and total switching energy (ETS) than punch-through (PT) and non-punch-through (NPT) type IGBTs. In addition, the internal ultrafast soft recovery diode improves efficiency and reduces EMI.

600V Trench Field Stop IGBTs

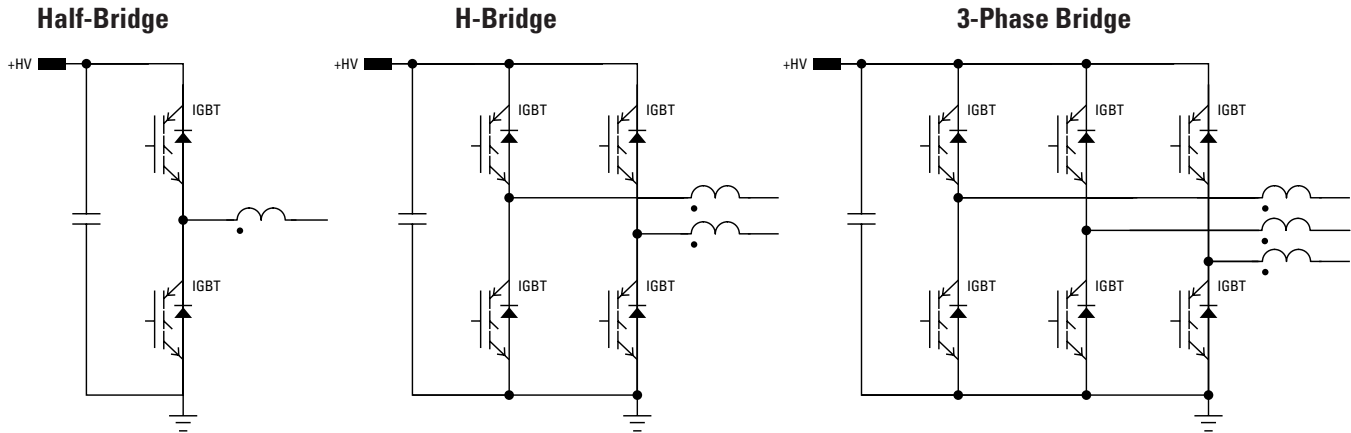

Traditionally, IGBT devices have excessive switching losses at higher frequencies used in UPS and solar inverters. IR's new Trench IGBT devices have low switching energy coupled with low conduction losses. These lower losses provide higher system efficiency, reducing the size of the magnetics and the cost of power generation to the end user.

Heatsink Temperature vs. Output RMS Current

$f_{SW} = 20\text{kHz}$, $R_{th(s-a)} = 5^\circ\text{C/W}$, $T_{AMB} = 30^\circ\text{C}$ Full Bridge DC-AC Inverter

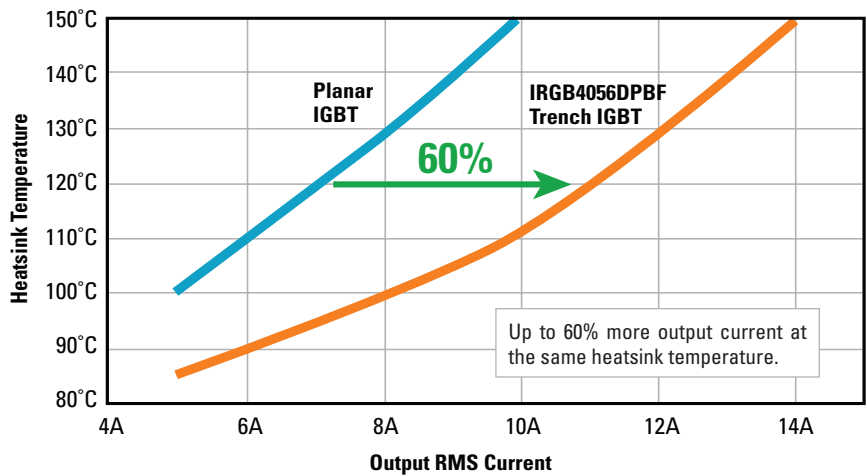

Package	Voltage	IC (Rated Current)	V _{CE(on)} (typ) @25°C	ETS typ (mJ) @25°C	TO-262	D-PAK	D ² PAK	TO-220	TO-247	TO-247 (Long Lead)	Super TO-247
Single-Pack	600	35	1.60	1.02					IRGP4069	IRGP4069-E	
Single-Pack	600	48	1.65	1.90					IRGP4063		
Single-Pack	600	75	1.70	4.62					IRGP4066	IRGP4066-E	
Co-pack	600	4	1.75	0.11				IRGB4059D			
Co-pack	600	6	1.70	0.18		IRGR4045D		IRGB4045D			
Co-pack	600	8	1.55	0.22				IRGB4060D			
Co-pack	600	10	1.60	0.23			IRGS4064D	IRGB4064D			
Co-pack	600	12	1.55	0.30			IRGS4056D	IRGB4056D			
Co-pack	600	18	1.65	0.45				IRGB4061D			
Co-pack	600	24	1.60	0.72	IRGSL4062D		IRGS4062D	IRGB4062D	IRGP4062D		
Co-pack	600	35	1.60	1.02					IRGP4069D	IRGP4069D-E	
Co-pack	600	48	1.65	1.90					IRGP4063D		
Co-pack	600	75	1.70	4.62					IRGP4066D	IRGP4066D-E	
Co-pack	600	120	1.70	9.18							IRGPS4067D