



Since April 1, 1999,
Siemens Semiconductor
is
Infineon Technologies.
The next revision of this
document will be updated
accordingly.

Microcontrollers

ApNote

AP0825

Power Supply Concept for the C515C 8-Bit Microcontroller

This application note introduces a power supply concept for the C515C and deals with the enhanced feature of this controller to switch off the Address Latch Enable (ALE) output signal during accesses to internal ROM.

H. Kern / Siemens Application Support

Contents		Page
1	Introduction	3
2	Dedicated Power Supply Pins of the C515C	3
3	On-chip Power Supply Concept	3
4	PCB Power Supply Concept	4
5	ALE Switch Off Feature	5
6	Conclusion	6

AP0825 ApNote - Revision History		
Actual Revision : 05.97		Previous Revision : none (Original Version)
Page of actual Rev.	Page of prev.Rel.	Subjects (changes since last release)

1 Introduction

This application note describes a power supply concept for the Siemens C515C 8-Bit microcontroller and introduces a corresponding suggestion for a corresponding PCB schematic. Moreover this paper deals with the enhanced feature of the C515C, which is to switch off the Address Latch Enable output signal (ALE) while accessing internal code memory (ROM). A significant improvement of the EMC behavior of this controller can be achieved with this feature.

2 Dedicated Power Supply Pins of the C515C

Ten pins of the C515C 8-Bit microcontroller are dedicated power supply pins, which are more than 12% of all pins of the MQFP 80 package. These pins are arranged and grouped into power supply and ground pins and used to connect the controller to the external 5V power supply. The symbolic names and pin numbers are listed in table 1 and table 2 below. The pin configuration of the C515C is shown in figure 1.

3 On-chip Power Supply Concept

The C515C has two on-chip power supply rings. One power ring supplies the core and the peripherals (Oscillator circuit, ADC, Timer Units, SSC, USART, CAN etc.). The other one is used to feed the I/O ports (pads). Each of these two power rings is at least connected to two supply pin pairs. These multiple supply nodes lead to a balanced supply voltage all over the chip and to stable V_{OL} and V_{OH} levels. The pin pairs V_{CC1}/V_{SS1} and V_{CCCLK}/V_{SSCLK} belong to the power ring for the internal logic. The power ring for the pads is connected to the three supply pin pairs V_{CCE1}/V_{SSE1} , V_{CCE2}/V_{SSE2} and V_{CCEXT}/V_{SSEXT} . The two power rings are connected internally only at the pins V_{CC1}/V_{CCE1} and V_{SS1}/V_{SSE1} over bond wires. Due to this, the interferences between the two power rings are minimized. Additionally, the C515C provides on-chip decoupling capacitors, building in sum approx. 800 pF. These measures lead to an approach towards improved EMC behavior of this device.

Table 1 :
Supply pin pairs for the core and peripherals

Symbol	Pin Number	Symbol	Pin Number	Function
V_{CC1}	33	V_{SS1}	34	supply pin pair for the core and the peripherals
V_{CCCLK}	14	V_{SSCLK}	13	supply pin pair for the on-chip oscillator circuit, the core and the peripherals

Table 2 :
Supply pin pairs for the I/O ports

Symbol	Pin Number	Symbol	Pin Number	Function
V_{CCE1}	32	V_{SSE1}	35	supply pin pair for the I/O ports (pads)
V_{CCE2}	68	V_{SSE2}	70	supply pin pair for the I/O ports (pads)
V_{CCEXT}	50	V_{SSEXT}	51	supply pin pair for the I/O ports (pads)

4 PCB Power Supply Concept

In general, separate V_{CC} and V_{SS} planes are recommended for the PCB layout and ceramic SMD capacitors (X7R) should be used as decoupling capacitances in order to obtain best EMC behavior. Figure 1 introduces a suggestion, whereby the controller is connected to the supply voltage with all of its supply pin pairs. The pin pairs V_{CC1}/V_{SS1} and V_{CCE1}/V_{SSE1} have also to be connected externally (on the PCB) and can be handled as one supply input (see figure 1). Each supply input should be blocked with a SMD capacitor of 33 nF. These block capacitors should be placed as near as possible to the power supply pins of the controller in order to avoid parasitical inductances. For PCB layouts, which do not use separate V_{CC} and V_{SS} planes, it is recommended to feed the C515C straight from one 5V voltage source to V_{CC1}/V_{SS1} and to connect the other power supply pins directly to this point. This suggestion may fit for many applications but should not be regarded as the only possible solution.

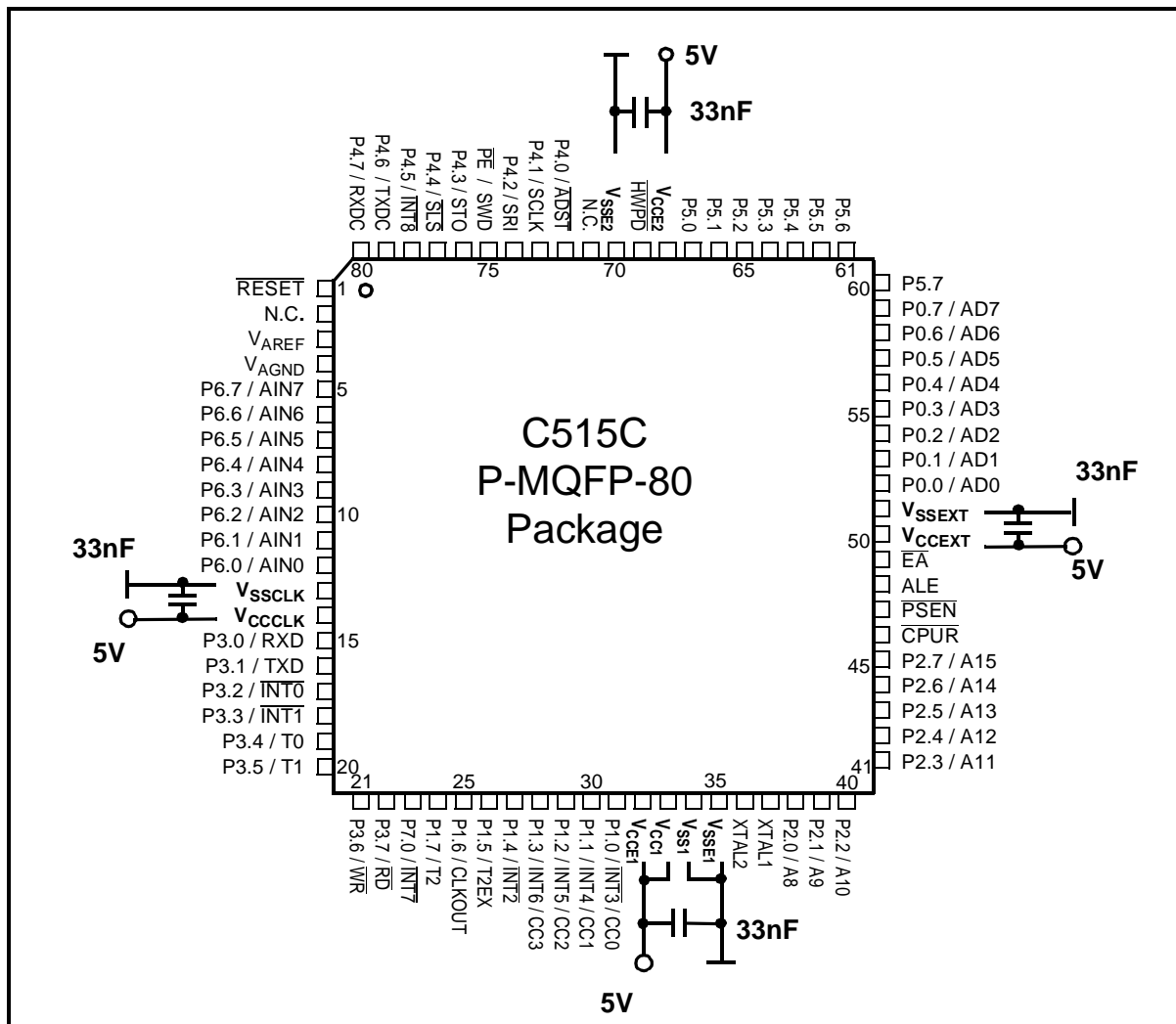

Figure 1 :
Schematic of the PCB power supply concept for the C515C

5 ALE Switch Off Feature

In order to improve the EMC behavior of this device, when using internal ROM, the C515C allows to switch off the Address Latch Enable output signal (ALE). This enhanced capability can only become active if internal ROM is used ($\overline{EA}=1$). With pin $\overline{EA}=1$ there is no port activity at Port 0 and Port 2 while accessing internal code memory, but the ALE output signal is still generated. The ALE signal can be suppressed by clearing bit EALE (Enable ALE output) in SFR SYSCON (located at address B1H) and ALE output will only become active during external data memory accesses. After a hardware reset the ALE generation is enabled. Reset value: EALE = 1

The comparison of EMC measurements according to VDE 767.14 indicates the contribution of the ALE output signal to the global EME. The usage of the ALE switch off feature can reduce the global EME up to 15 dB μ V within the lower frequency range up to 80 MHz during internal code memory accesses. This significant impact of the ALE switch off feature of the C515C is shown in figure 2. The bright curve (C515C ALE ON) corresponds to the measurement done with activated ALE output signal and the dark curve (C515C ALE OFF) corresponds to the measurement done with deactivated ALE output signal while accessing internal ROM ($\overline{EA}=1$).

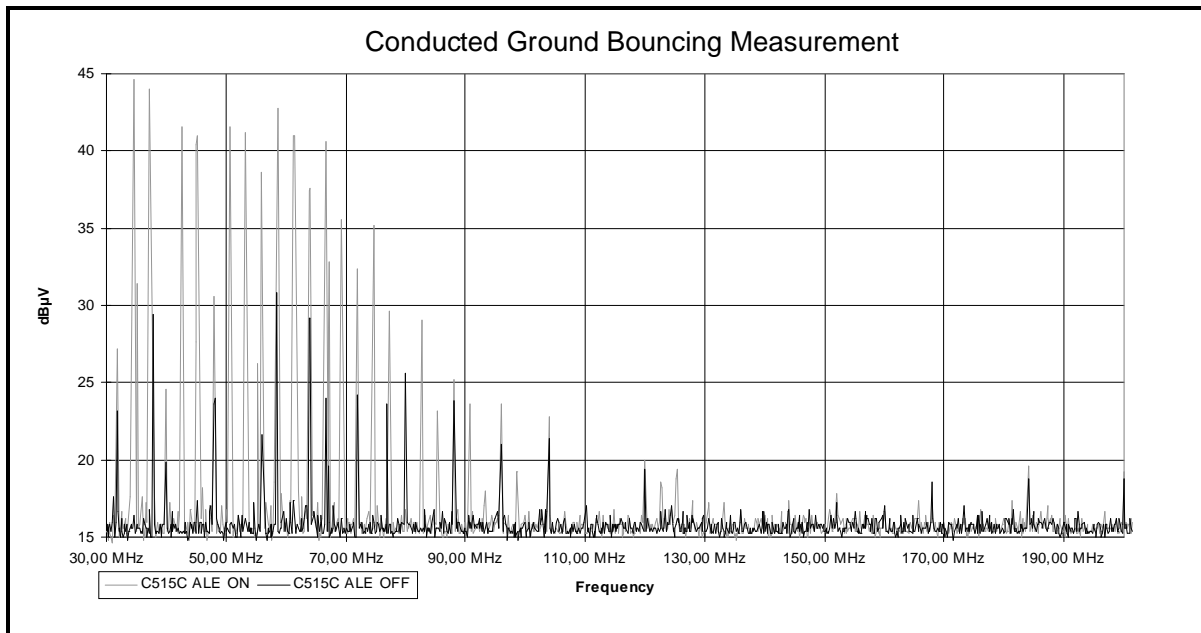

Figure 2 :
Comparison of the EME behavior of the C515C with ALE on/off

Measurement conditions: EMC measurements according to VDE 767.14
 Device: C515C
 \overline{EA} : 1
 fosc: 8 MHz
 Supply Voltage: 5 V
 Temperature: 20 °C

Note: This VDE EMC measurements are relative measurements covering ground bouncing. EMC investigations done in an absorbing hall with radio meter and antennas may deliver deviating results.

6 Conclusion

Optimized EMC behavior of the application circuit is typically an important demand to be fulfilled in automotive applications. This requirement becomes more and more necessary for other application segments, too.

The improved internal power supply concept of the C515C is an approach towards improved EMC behavior of this microcontroller. The explanations and PCB design hints given in this application note show how to use this new internal power supply concept in order to obtain optimized EMC behavior.

Additionally, the above described ALE switch off feature of the Siemens C515C 8-Bit microcontroller can contribute to an improved EMC behavior of the application.