

Application Note

IRS20954S and IRS20957S Comparison

Table of Contents

	Page
Introduction	2
Block Diagram.....	2
Electrical Characteristic Differences.....	3
VCLAMPH Differences.....	5
Logic Status Differences	5
Summary.....	6

Introduction

The IRS20957S is a high voltage, high speed MOSFET driver with a floating PWM input designed for Class D audio amplifier applications. The IRS20957S is an improved version of the IRS20954S. This application note describes the differences between the IRS20954S and IRS20957S.

Block Diagram

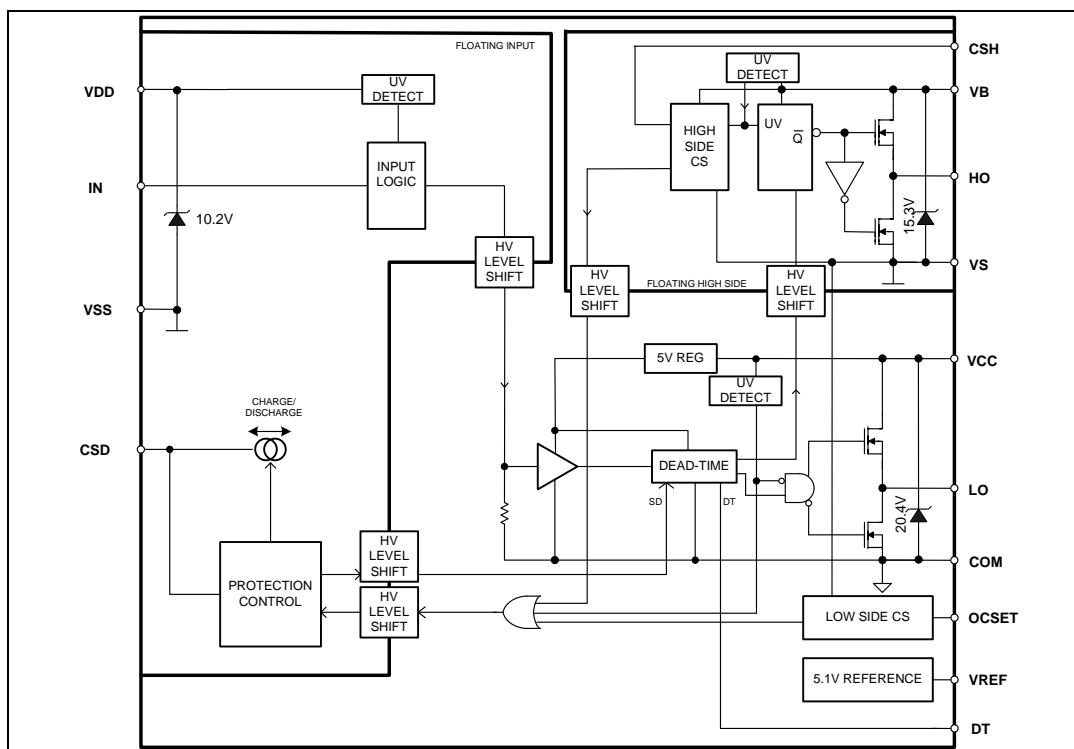

The IRS20954S and the IRS20957S share the same functional structure. In normal operating conditions, there are no functional changes between corresponding part numbers.

Electrical Characteristic Differences

All measurement conditions are the same for both the IRS20954S and IRS20957S.

Absolute Maximum Ratings

Symbol	Definition	IRS20954S			IRS20957S			Units
		Min	Typ	Max	Min	Typ	Max	
V _B	High side floating supply voltage	-0.3	-	220	-0.3	-	215	V
V _S	High side floating supply voltage (†)	V _B -20	-	V _B +0.3	V_B -15	-	V _B +0.3	V

† V_{DD} - V_{SS}, V_{CC} - COM and V_B - V_S contain internal shunt zener diodes. Please note that the voltage ratings of these can be limited by the clamping current.

Recommended Operating Conditions

Symbol	Definition	IRS20954S			IRS20957S			Units
		Min	Typ	Max	Min	Typ	Max	
V _B	High side floating supply absolute voltage	V _S +10	-	V _S +18	V _S +10	-	V_S+14	V
V _{CC}	Low side fixed supply voltage	10	-	18	10	-	15	V
I _{PW}	Input pulse width	10 (Note)	-	-	-	-	-	ns

Note: Output logic status may not respond correctly if input pulse width is smaller than the minimum pulse width.

Electrical Characteristics

Symbol	Definition	IRS20954S			IRS20957S			Units
		Min	Typ	Max	Min	Typ	Max	
Ton_1	High and low side turn-on propagation delay, floating inputs	-	105	-	-	95	-	ns
Toff_1	High and low side turn-off propagation delay, floating inputs	-	90	-	-	80	-	ns
Ton_2	High and low side turn-on propagation delay, non-floating inputs	-	105	-	-	95	-	ns
Toff_2	High and low side turn-off propagation delay, non-floating inputs	-	90	-	-	80	-	ns
DT4	Deadtime: LO turn-off to HO turn-on (DTLO-HO) & HO turn-off to LO turn-on (DTHO-LO)VDT=VDT4	25	45	60	50	80	110	ns

Static Electrical Characteristics

Symbol	Definition	IRS20954S			IRS20957S			Units
		Min	Typ	Max	Min	Typ	Max	
V _{CLAMP}	High side zener diode clamp voltage	19.8	20.8	21.8	14.7	15.3	16.2	V

Logic Status Differences

Narrow Pulse Behavior

In the IRS20954S, a narrow input pulse below 10 ns, such as spikes from switching stage, may flip the logic states of LO and HO opposite to the input. Next transition in input PWM fixes the inverted logic in the output. However, this wrong logic status is harmful in self-oscillating type topologies because it makes the system latch up and stop operation.

With natural PWM topologies, pulse width can be as narrow as 1ns that leads the wrong logic status with IRS20954S.

The IRS20957S ignores narrow input pulses. The logic states of HO and LO does not respond to the input of the IC if pulse width is less than 50ns, providing more noise immunity to systems using self-oscillating type topologies.

V_{CLAMPH} Differences

Pre-charging with VBS Zener Diode

During start up sequence, pre-charging bootstrap power supply through positive bus voltage might be necessary to start self oscillating PWM. It would be convenient to integrate 15V zener diode to clamp the high side power supply, V_{BS} , for applications with MOSFETs that have rated gate voltage of 20V.

Upgrading IRS20954 with IRS20957

Current Design with IRS20954S		Action Item for IRS20957S
Deadtime	Vcc	
DT1-3	>15V	Reduce Vcc to 15V or less.
	Up to 15V	Direct replacement.
DT4	>15V	Reduce Vcc to 15V or less.
	Up to 15V	Direct replacement with wider deadtime.

Summary

The IRS20957S is an improved version of the IRS20954S with shorter propagation delay. The longer deadtime window of IRS20957S enables use of MOSFET with larger gate charge. Applications using a natural PWM topology should use the IRS20957S. The IRS20957S has more immunity to incoming noise in IN pin. The IRS20954S is no longer recommended for new designs.