



XC835/XC836

Smart 8-bit Microcontrollers for Industrial Applications

The XC83x-Series is the advanced entry level for Infineon's 8-bit microcontroller family XC800 running at 24MHz. A comprehensive set of peripherals with 4KB and 8KB Flash memory is now available in low pin count packages.

Communication interfaces and fast control loops with multichannel 10-bit ADCs and PWM signal generation are featured as well as safety and low power modes. The vector computer co-processor (MDU + CORDIC) boosts up standard 8-bit processing performance and supports field oriented motor control at 8-bit cost. This enables more efficient and intelligent designs for motor control (e.g. sensorless motors), lighting or power stage control.

With the I²C interface and the integrated capacitive touch control functionality the XC835 and XC836 expand the feature set of the XC800 family to fit more industrial and home appliance markets.

Applications

- Efficient Drives & Automation
 - Field oriented control of sensor less motor drives
 - Direct operation of stepper motors for displays
 - Automation networks for industrial production or building services
- Intuitive human machine interfaces
 - Multi gestural touch screens for industrial automation, medical devices or POS terminals
 - Integrated control elements with motor control, communication or power conversion functionality
- Intelligent Lighting
 - Dimming and color control of high brightness LEDs
 - Power, ignition or wear out control of HID
 - Lighting communication networks
- Smart Power Management
 - Efficient power conversion
 - Battery management
 - Induction cooking

www.infineon.com

Key Features

- Touch control with advanced ROM-library
- Vector computer co-processor for field oriented control of sensor less motors
- 10-bit ADC with high accuracy over 8 channels. Fast conversion in 1 μ s.
- Capture/Compare Unit (CCU6) dedicated for flexible PWM signal generation over 4 channels
- Direct HW-link between ADC and CCU6 for fast control loops
- Serial interfaces: UART, SPI, I²C
- Power down/wake up modes
- Real time clock
- High current pads to directly drive stepper motors or LED-displays
- Background E²PROM emulation

The XC83x-Series is fully supported by Infineon's free tool chain DAVE Bench for fast time to market.

XC835/XC836

Smart 8-bit Microcontrollers for Industrial Applications

Block Diagram

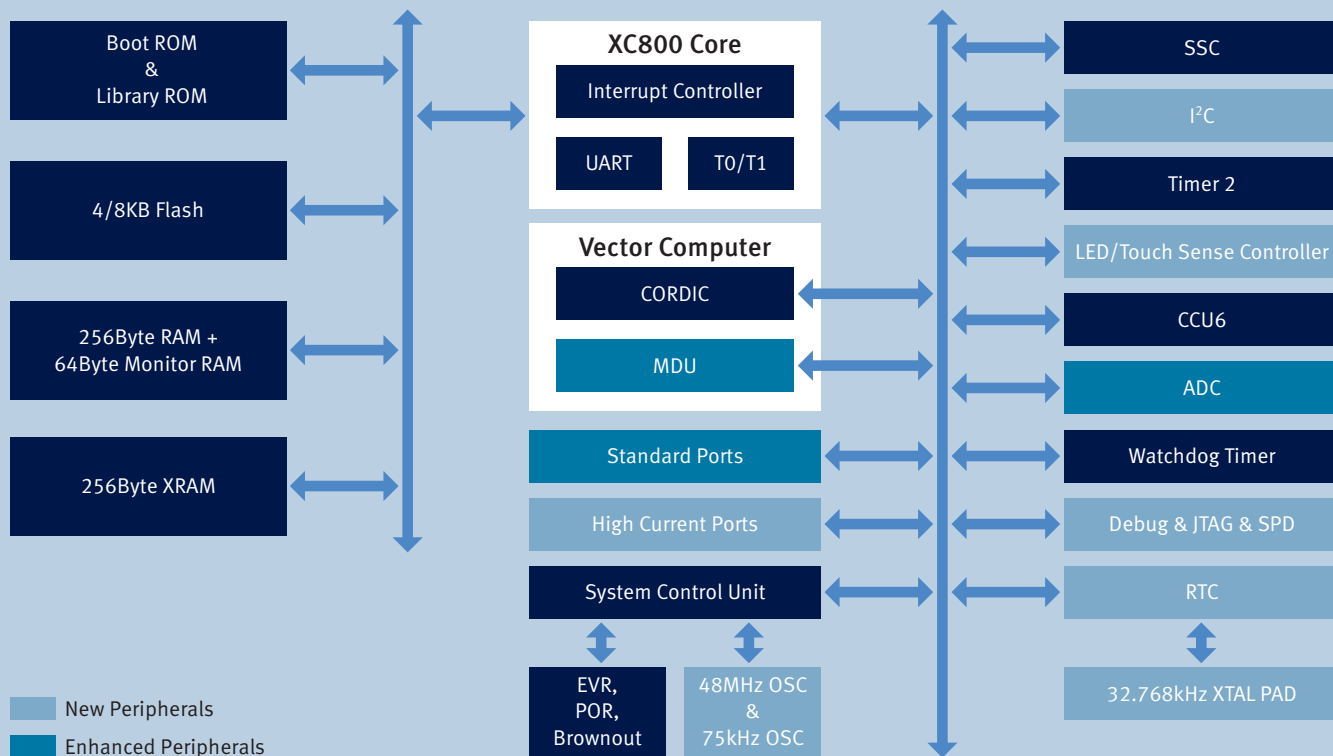

Availability

Sales Code	Flash [KB]	Touch Control	VC ¹⁾	Temperature [°C]	Package
SAF-XC835MT-2FGI	8	yes	yes	-40 ... 85	PG-DSO-24
SAF-XC836T-2FRI	8	yes	no	-40 ... 85	PG-TSSOP-28
SAF-XC836M-1FRI	4	no	yes	-40 ... 85	PG-TSSOP-28
SAF-XC836M-2FRI	8	no	yes	-40 ... 85	PG-TSSOP-28
SAF-XC836MT-2FRI	8	yes	yes	-40 ... 85	PG-TSSOP-28
SAF-XC836-2FRI	8	no	no	-40 ... 85	PG-TSSOP-28

1) VC = Vector Computer (MDU + CORDIC)

How to reach us:
<http://www.infineon.com>

Published by
 Infineon Technologies AG
 81726 Munich, Germany

© 2010 Infineon Technologies AG
 All Rights Reserved.

Legal Disclaimer The information given in this Product Brief shall in no event be regarded as a guarantee of conditions or characteristics. With respect to any examples or hints given herein, any typical values stated herein and/or any information regarding the application of the device, Infineon Technologies hereby disclaims any and all warranties and liabilities of any kind, including without limitation, warranties of non-infringement of intellectual property rights of any third party.

Information For further information on technology, delivery terms and conditions and prices, please contact the nearest Infineon Technologies Office (www.infineon.com).

Warnings Due to technical requirements, components may contain dangerous substances. For information on the types in question, please contact the nearest Infineon Technologies Office. Infineon Technologies components may be used in life-support devices or systems only with the express written approval of Infineon Technologies, if a failure of such components can reasonably be expected to cause the failure of that life-support device or system or to affect the safety or effectiveness of that device or system. Life support devices or systems are intended to be implanted in the human body or to support and/or maintain and sustain and/or protect human life. If they fail, it is reasonable to assume that the health of the user or other persons may be endangered.