

Package Outline

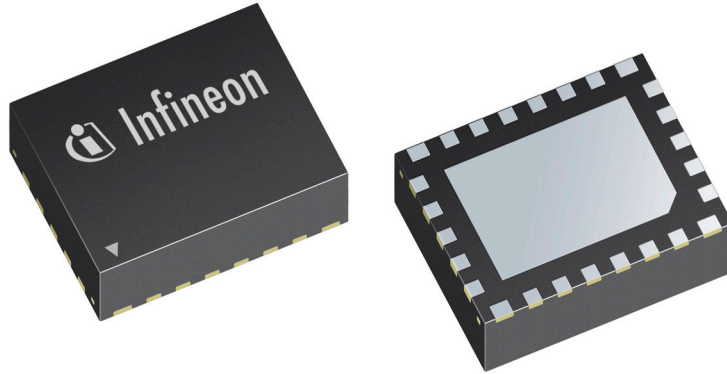

Top view

Bottom view

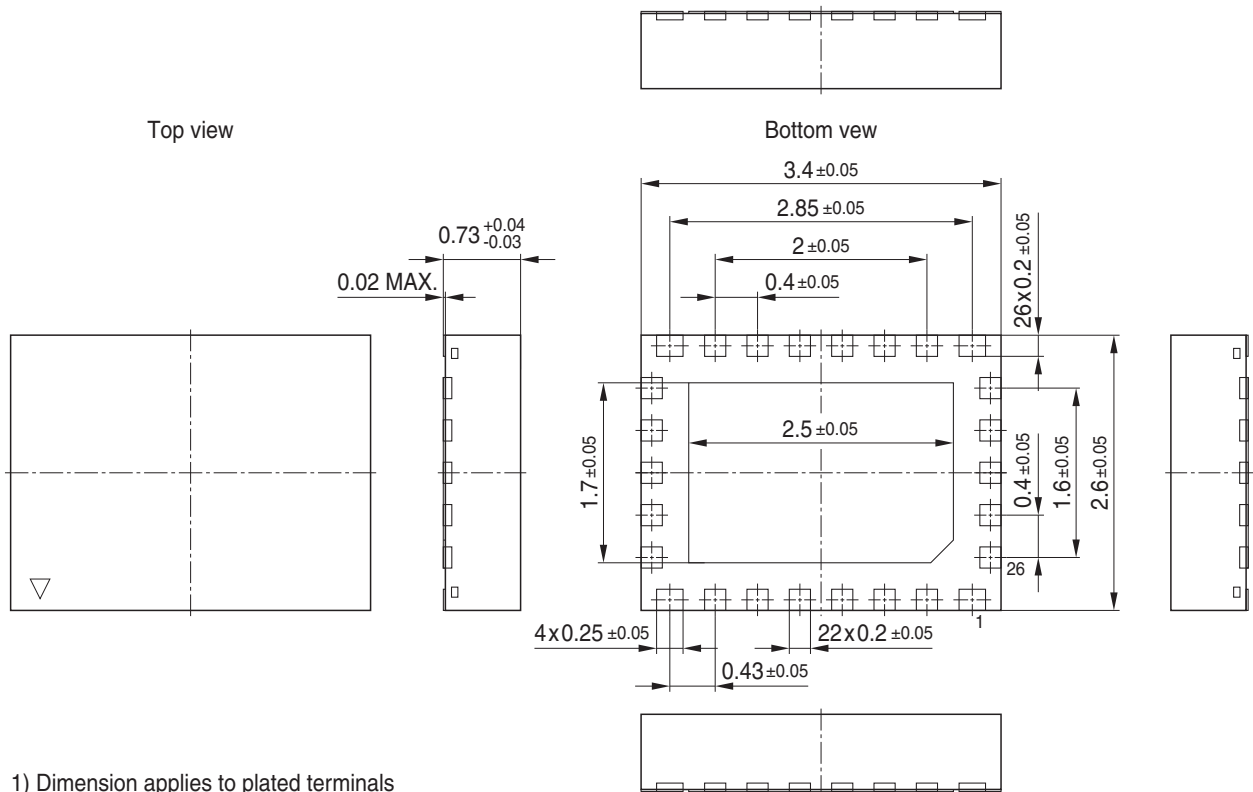

1) Dimension applies to plated terminals

Foot Print

Soldering Type: Reflow Soldering

NSMD

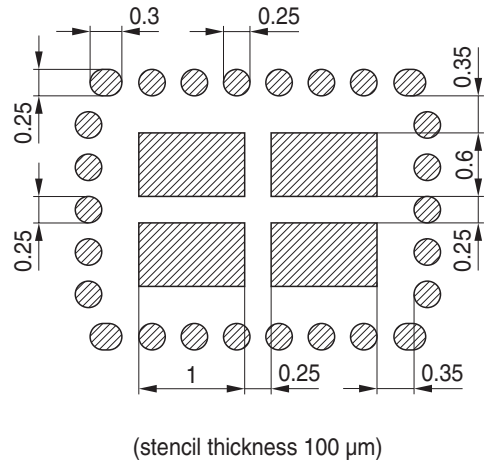
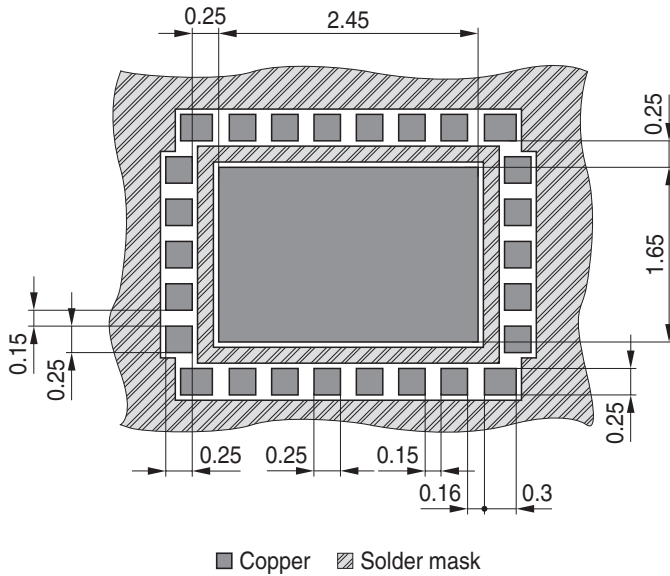

Marking Layout

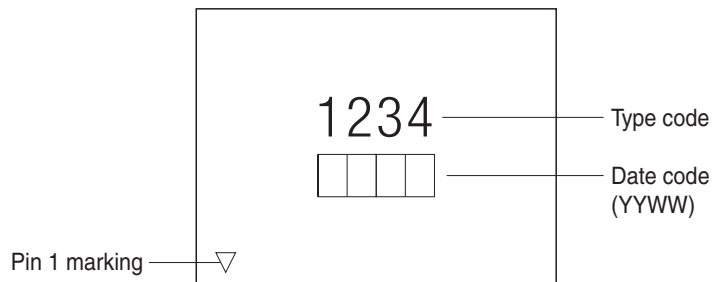

Tape and Reel

Reel ø180 mm: 2.000 Pieces/Reel
 Reels/Box: 1

