

Package Outline

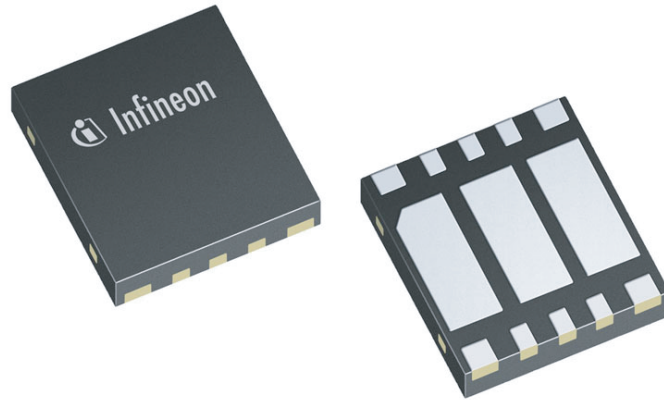

Top view

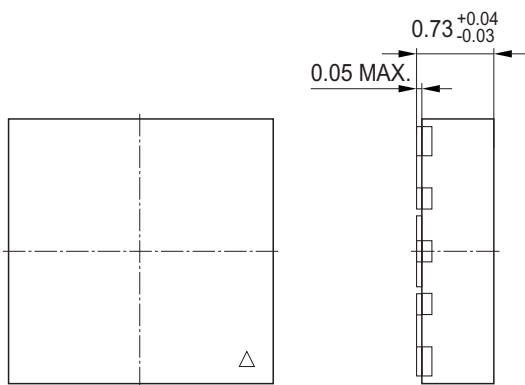

Bottom view

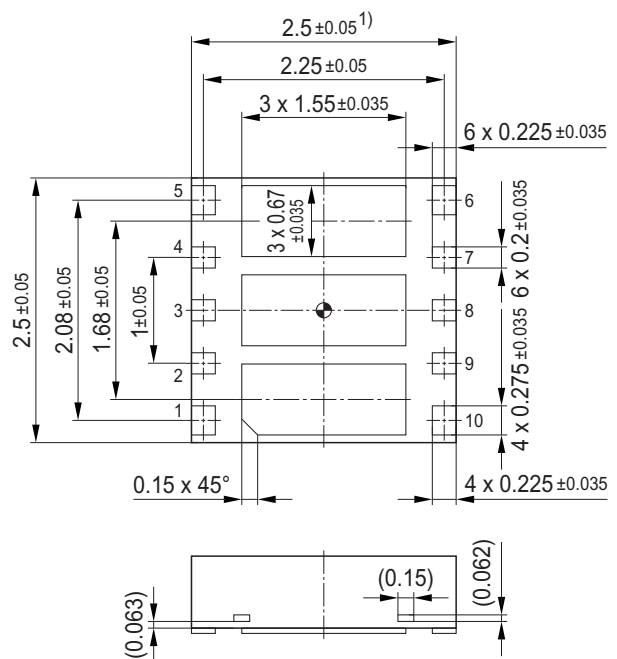

1) Dimension applies to plated terminals

Foot Print

Soldering Type: Reflow Soldering

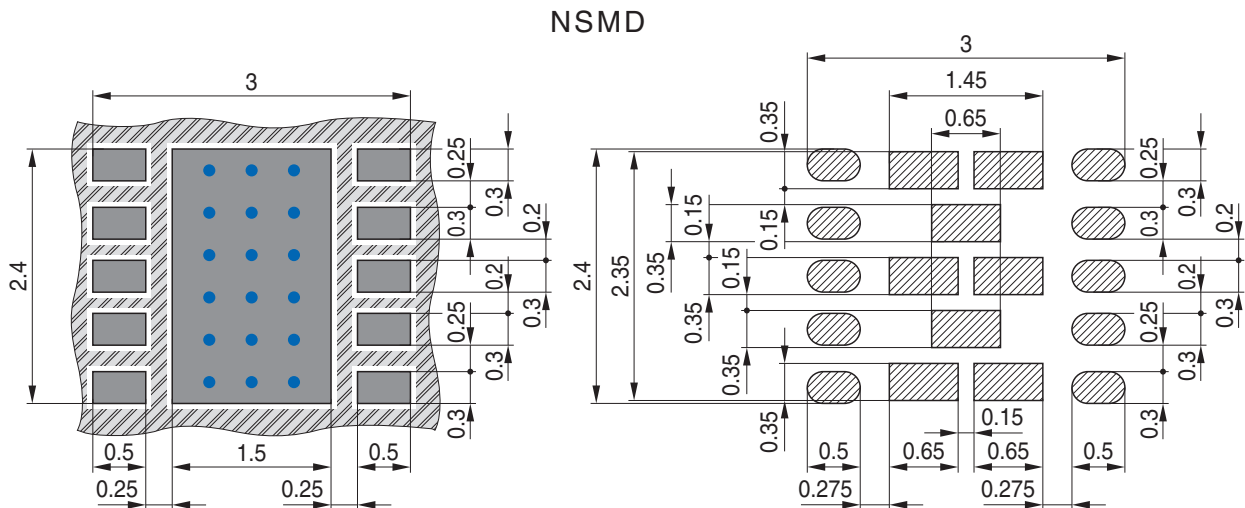

Recommendations for solder mask openings and microvia dimensions

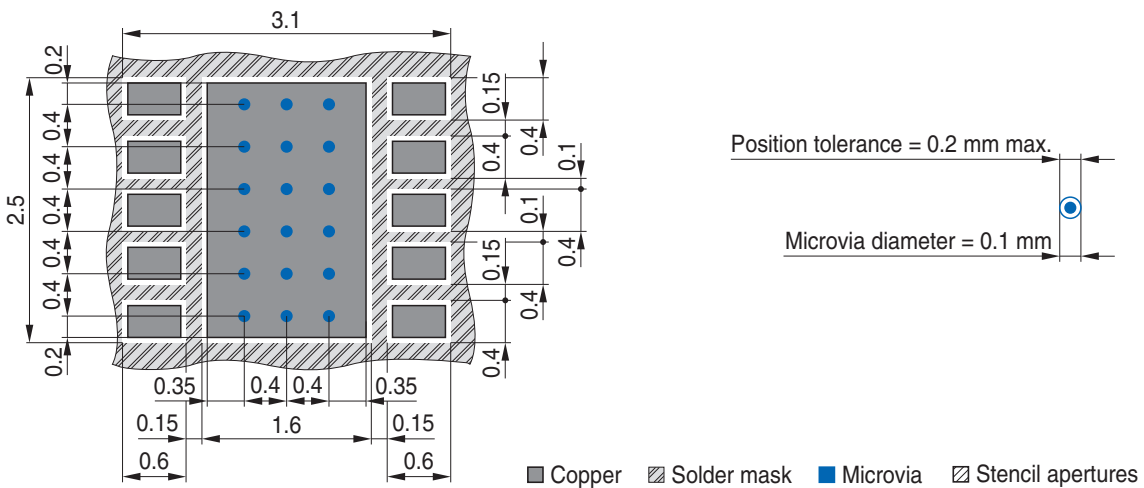

Foot Print

Soldering Type: Reflow Soldering

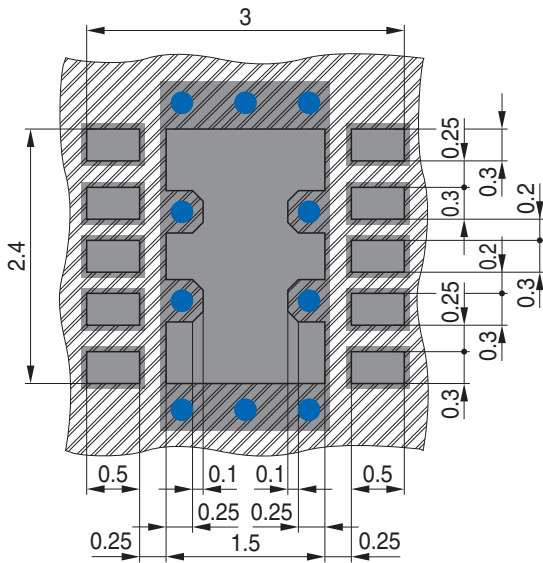

SMD

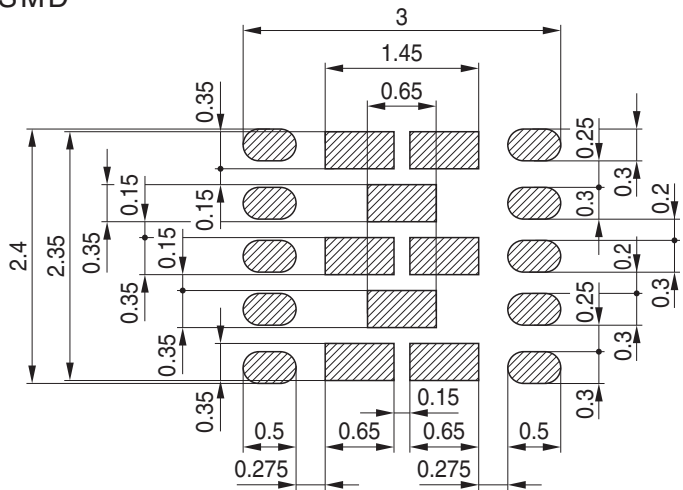

Recommendations for copper pad and via dimensions

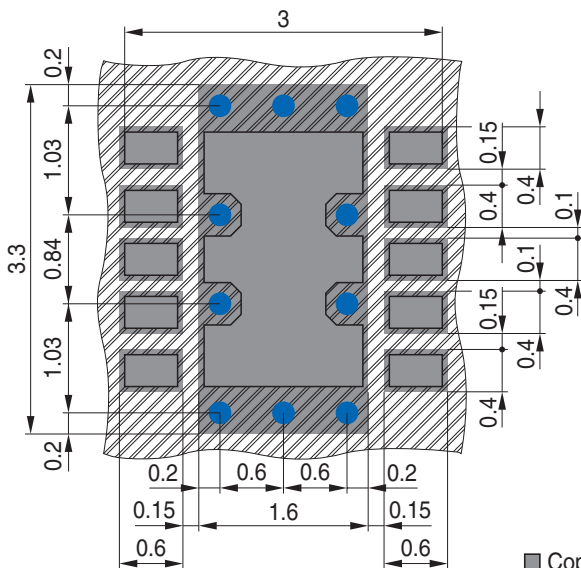

Via position tolerance = 0.4 mm max.

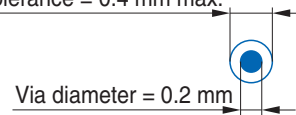

■ Copper ■ Solder mask ■ Via ■ Stencil apertures

Marking Layout

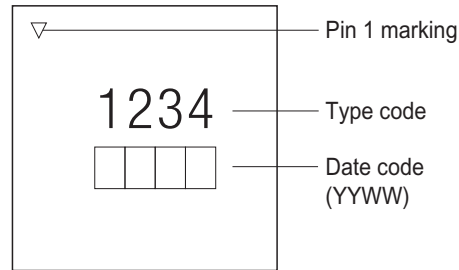

Tape and Reel

Reel \varnothing 180 mm: 3.000 Pieces/Reel
 Reels/Box:

