

Package Outline

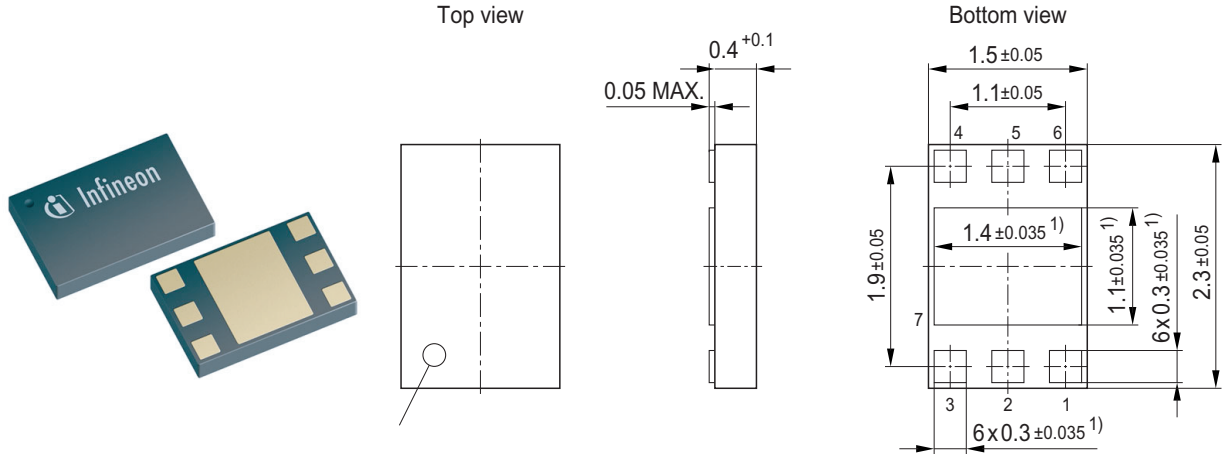

1) Dimension applies to plated terminal

Foot Print

Soldering Type: Reflow Soldering

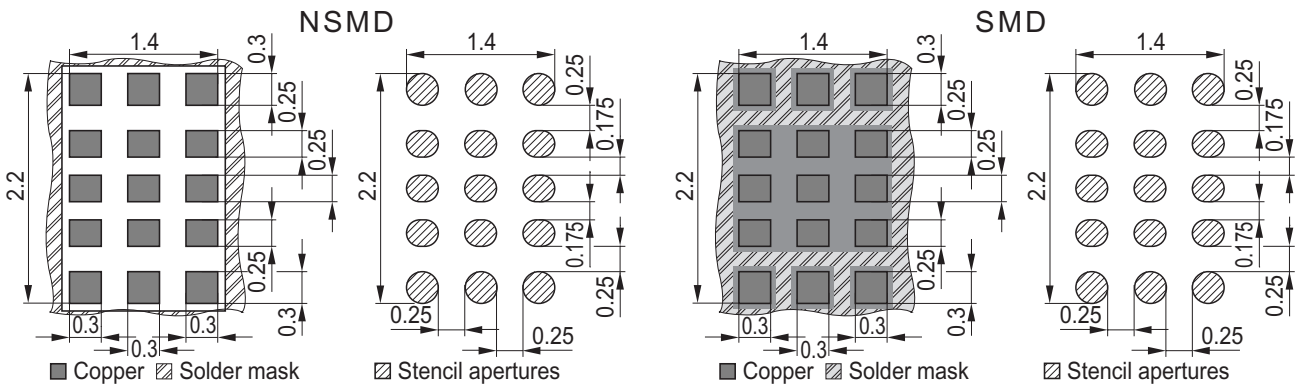

Marking Layout (Example)

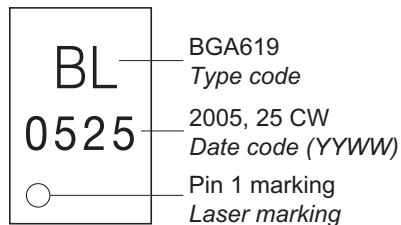

Tape and Reel

Reel ø330 mm: 7.500 Pieces/Reel
Reels/Box: 1

