

The TLE 6216/17G is a Smart Quad Channel Low-Side Switch for automotive and industrial applications. The design is based on Infineon's Smart Power Technology (SPT) which allows bipolar, CMOS and power DMOS devices on the same monolithic circuit. All kinds of resistive and inductive loads (relays, electromagnetic valves) can be controlled and switched. The device has four open drain DMOS output stages with separate inputs. Fully embedded protection functions against overload, overvoltage, short circuit, overtemperature and electrostatic discharge (ESD) guarantee a robust design without external components. One digital output per channel indicates the status of the integrated circuit. Overload and overtemperature will shutdown the device. Integrated clamp-diodes limit voltage overshoots produced when inductive loads are demagnetized.



Power P-DSO-20-12

Applications

- Low-Side Switch for resistive and inductive loads (relays, electromagnetic valves)
- μC compatible power switch for 12 and 24 V applications
- Solenoid control switch in automotive (e.g. ABS, ESP) and industrial control systems

Features

- Four open drain output stages
- Output current $I_{D1,2}$ 2 x 5 A, $I_{D3,4}$ 2 x 3 A
- Low On resistance $R_{ON1,2}$ typical 0.2 Ω , $R_{ON3,4}$ typical 0.35 Ω
- Supply voltage V_S 4.8 - 32 V
- Drain source voltage $V_{DS(AZ)}$ max 60 V
- Separate diagnostic pin for each channel
- Global enable function

- Standby mode with low current consumption
- Parallel control of the inputs (PWM applications)
- Open load (on/off)
- Overload and thermal shutdown
- μC compatible input
- Protection against short circuit, overtemperature, overvoltage and ESD
- EMI and EMC advanced design
- Power P-DSO-20 Package with integrated cooling area or bare die

TLE 6216/17G

2 x 3 A / 2 x 5 A Smart Quad Channel Low-Side Switch for Resistive and Inductive Load Control Applications



TLE 6216G/TLE 6217G Block Diagram

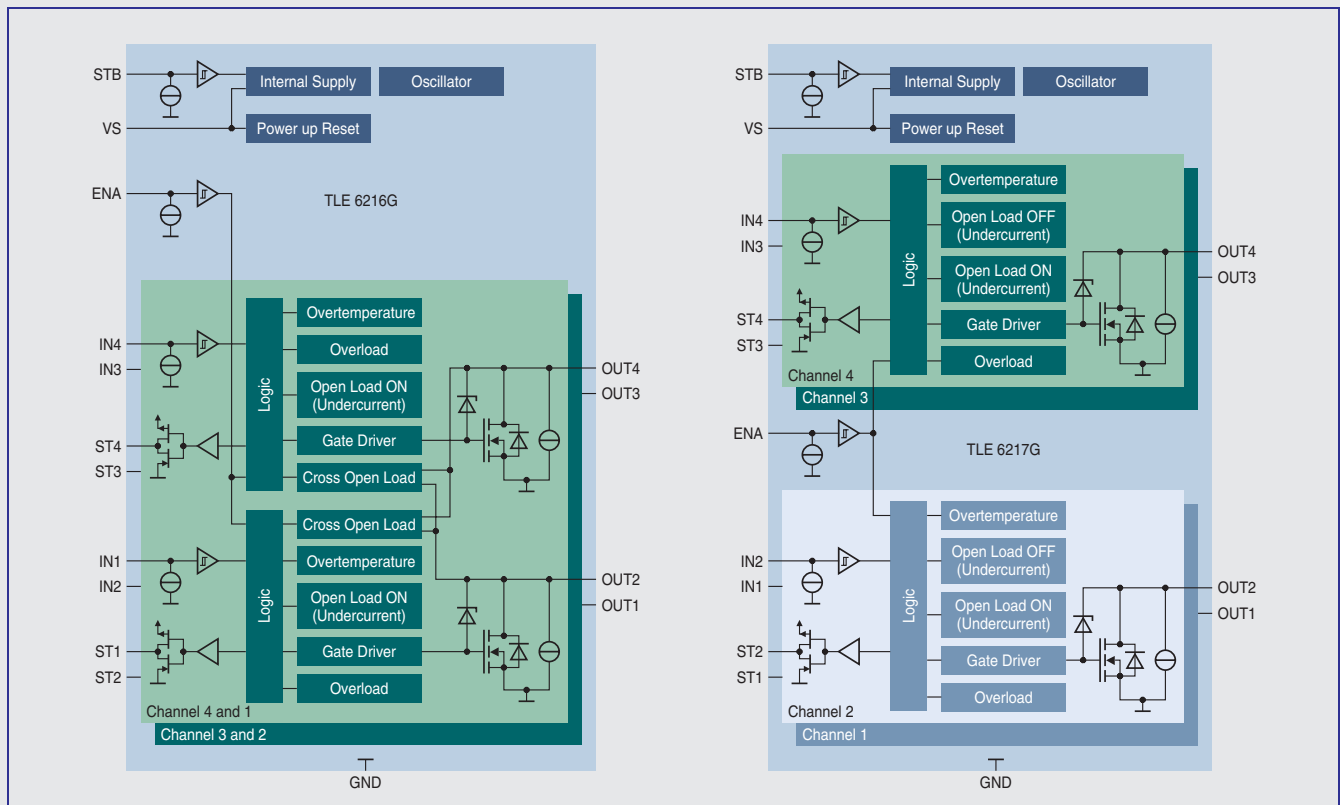

The difference between both products is the cross open load detection which is integrated in the TLE 6216G.

Type	Sales Code	Channels	Output Current I_D per Switch	$R_{DS(ON)}$ per Switch	Package
TLE 6215G	Q67007A9612	2	2 x 4 A	2 x 210 m Ω	P -DSO-24-3
TLE 6216G	Q67007A9626	4	2 x 3 A, 2 x 5 A	2 x 200, 2 x 350 m Ω	P -DSO-20-12
TLE 6217G	Q67007A9619	4	2 x 3 A, 2 x 5 A	2 x 200, 2 x 350 m Ω	P -DSO-20-12

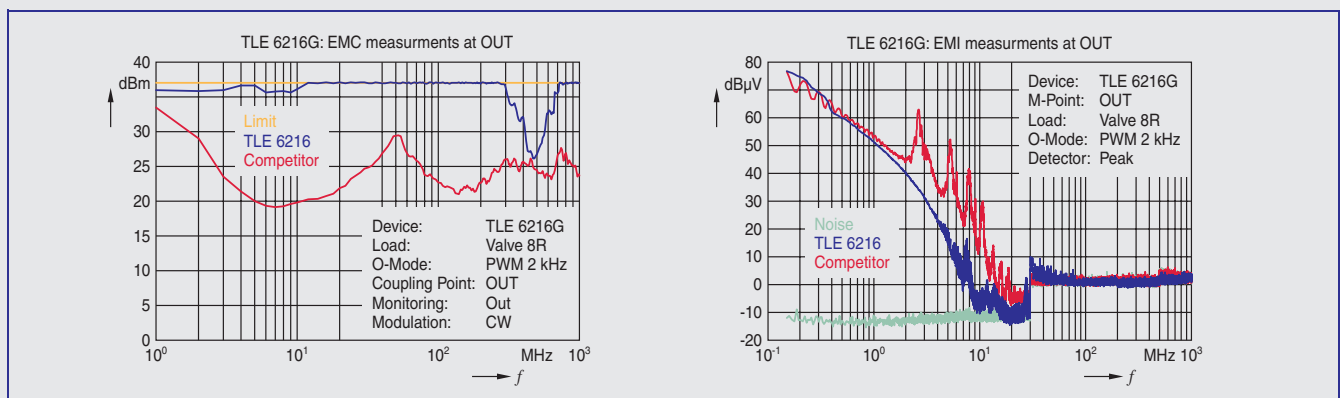

The TLE 6216/17G are advanced pin compatible derivatives from the TLE 6228G. Against the competitor the devices show an improved EMI and EMC performance.

How to reach us:
<http://www.infineon.com>

Published by
Infineon Technologies AG,
 St.-Martin-Strasse 53,
 D-81669 München

© Infineon Technologies AG 2003. All Rights Reserved.

Attention please!

The information herein is given to describe certain components and shall not be considered as a guarantee of characteristics.

Terms of delivery and rights to technical change reserved.

We hereby disclaim any and all warranties, including but not limited to warranties of non-infringement, regarding circuits, descriptions and charts stated herein.

Information

For further information on technology, delivery terms and conditions and prices please contact your nearest Infineon Technologies Office.

Warnings

Due to technical requirements components may contain dangerous substances. For information on the types in question please contact your nearest Infineon Technologies Office.

Infineon Technologies Components may only be used in life-support devices or systems with the express written approval of Infineon Technologies, if a failure of such components can reasonably be expected to cause the failure of that life-support device or system, or to affect the safety or effectiveness of that device or system. Life support devices or systems are intended to be implanted in the human body, or to support and/or maintain and sustain and/or protect human life. If they fail, it is reasonable to assume that the health of the user or other persons may be endangered.

Template: pb_tmplt.fm/3/2003-07-01