

TLE8088

One Chip Engine Management Power Interface Solution for Smallest 1 Cylinder Engines

The TLE8088EM is an Engine Management System IC which includes the minimum features to support 1 cylinder combustion engines with focus on the state-of-the-art technology Electronic Fuel Injection (EFI).

The TLE8088EM contains a 5V power supply, a K-line transceiver and 2 power stages.

Basic protection and diagnosis features are included: Overtemperature, overcurrent protection, undervoltage reset and open-load in Off.

Applications

4 stroke small combustion engine for:

- Motorcycle, 2- and 3- wheelers and scooters
- Watercraft, marines and jet-ski
- Snow mobiles, lawn-tractors or -mowers
- Small gasoline power generating sets

Key Features

- 5V supply including watch dog and reset
- 1 low-side driver for fuel injector
- 1 low-side driver for multifunction indication lamp
- K-line transceiver

Key Benefits

- Basic 1 cylinder engine management system functionality in one chip
- Small 150 mil SSOP-24 package saves board space
- Qualified according automotive standard AEC-Q100



TLE8088

Block Diagram

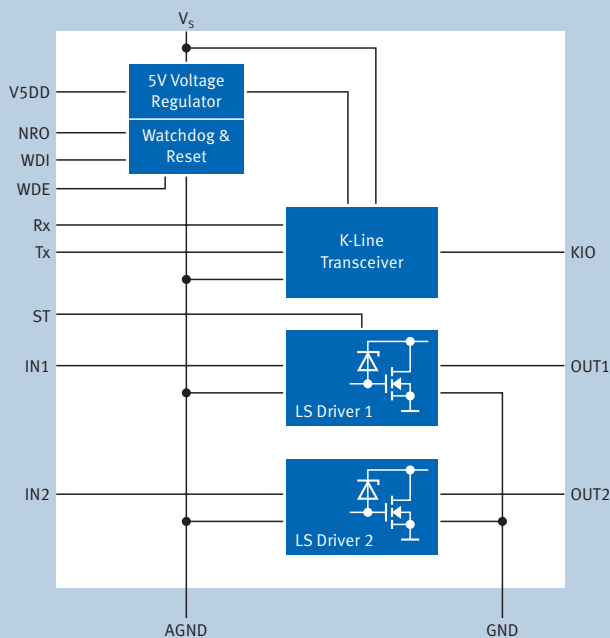

TLE8088EM

The **5V voltage regulator** supplies up to 150mA current and features under-voltage reset, power-on reset and watchdog. It includes protection circuits against over-load, short circuit and over-temperature conditions. The low-side switch function and the K-line transceiver are independent of the reset and watchdog signals.

The **K-line transceiver** is a serial link bus interface. It provides bi-directional half-duplex communication interfacing using the special ISO K-line and meets the ISO norm 9141 specification. The K-line bus output is protected against bus shorts and over temperature conditions.

The **low-side channels** are optimized for the use in engine management systems.

The recommended loads are:

- 1 channel for injectors or similar loads
- 1 channel for lamps or LEDs

Product	Supply Voltage Funct. Range [V]	5V Supply I_{V5DD} (max.) [mA]	Injector/Valve I_{OUT} Max. < 2.6A (Nom. = 1.3A)	MIL I_{OUT} Max. < 3A (Nom. = 300mA)	Relay Driver Max. < 350mA (Nom. = 300mA)	VRS I/F Variable Reluctance Interface	K-Line acc. ISO 9141	SPI I/F Diagnosis/Control Interface
TLE8088	6 – 18	150	✓	✓	–	–	✓	–
TLE8080	6 – 18	250	2x ✓	✓	2x ✓	✓	✓	✓

MIL = Malfunction Indication Lamp

Published by
Infineon Technologies AG
85579 Neubiberg, Germany

© 2012 Infineon Technologies AG.
All Rights Reserved.

Visit us:
www.infineon.com

Order Number: B126-H9589-G1-X-7600
Date: 03 / 2012

ATTENTION PLEASE!

The information given in this document shall in no event be regarded as a guarantee of conditions or characteristics ("Beschaffenheitsgarantie"). With respect to any examples or hints given herein, any typical values stated herein and/or any information regarding the application of the device, Infineon Technologies hereby disclaims any and all warranties and liabilities of any kind, including without limitation warranties of non-infringement of intellectual property rights of any third party.

INFORMATION

For further information on technology, delivery terms and conditions and prices please contact your nearest Infineon Technologies Office (www.infineon.com).

WARNINGS

Due to technical requirements components may contain dangerous substances. For information on the types in question please contact your nearest Infineon Technologies Office. Infineon Technologies Components may only be used in life-support devices or systems with the express written approval of Infineon Technologies, if a failure of such components can reasonably be expected to cause the failure of that life-support device or system, or to affect the safety or effectiveness of that device or system. Life support devices or systems are intended to be implanted in the human body, or to support and/or maintain and sustain and/or protect human life. If they fail, it is reasonable to assume that the health of the user or other persons may be endangered.