

Product Brief

TLE7257SJ

Basic LIN Transceiver starting up in Sleep Mode

The TLE7257SJ is a transceiver for the Local Interconnect Network (LIN) with integrated wake-up and protection features. It is designed for in-vehicle networks, using data transmission rates up to 20kbps. The TLE7257SJ operates as a bus driver between the protocol controller and the physical bus of the LIN network. Compliant to all LIN standards and with a wide operational voltage supply range, the TLE7257SJ can be used in all automotive applications.

The usage of different operation modes and the INH output allows the TLE7257SJ to control external components like e.g. voltage regulators. In sleep mode the TLE7257SJ draws typically less than 10 μ A of quiescent current while still being able to wake-up when detecting LIN bus traffic. The very low leakage current on the BUS pin makes the TLE7257SJ especially suitable for partially supplied networks.

The TLE7257SJ provides excellent ESD robustness together with a very high electromagnetic compatibility (EMC). It reaches a very low level of electromagnetic emission (EME) within a broad frequency range and independent from the battery voltage. The TLE7257SJ is AEC qualified and tailored to withstand the harsh conditions of the automotive environment.

Key Features

- Data rates up to 20kbaud
- Compliant to ISO 17987-4, LIN Specification 2.2A and SAE J2602
- Very high ESD robustness of ± 10 kV according IEC61000-4-2 and HBM
- Worldwide OEM approval
- Low electromagnetic emission
- High immunity against EMI
- Very low current consumption in sleep mode (10 μ A)
- Digital I/O levels compatible for 3.3V and 5V microcontrollers
- INH output to control external voltage regulator
- Bus short to V_{BAT} protection and Bus short to GND handling
- AEC Qualified

Applications

- Body Controllers and Gateway Modules
- Switch panels
- Wiper or window lift modules
- Door and Seat Control Modules
- Engine Management Units

TLE7257SJ

Basic LIN Transceiver starting up in Sleep Mode

Block Diagram TLE7257SJ

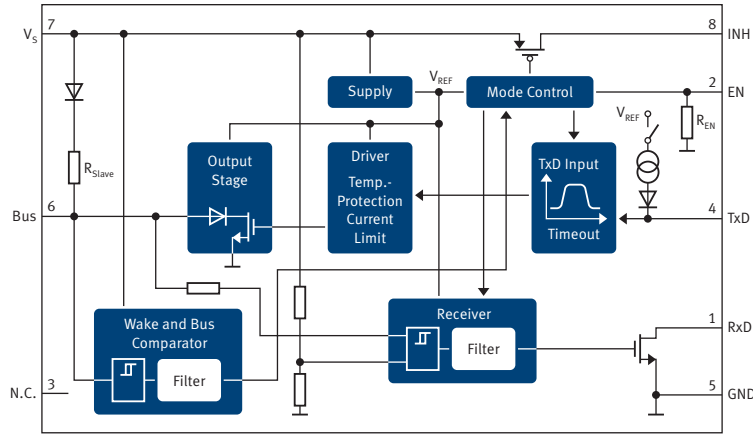

Application Example: Roof Control Module

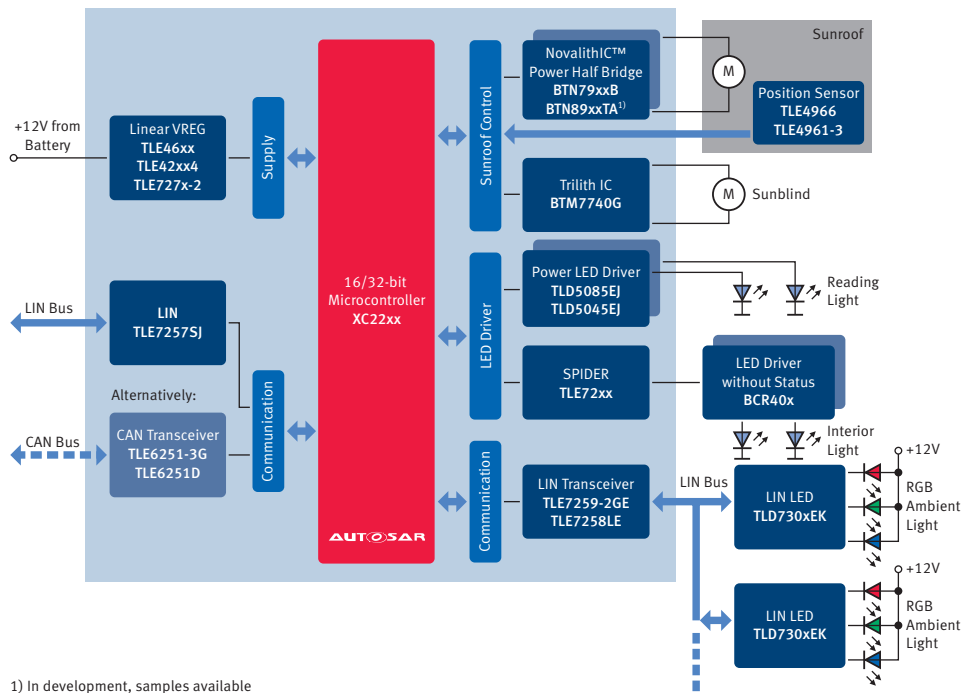

1) In development, samples available

Published by
Infineon Technologies AG
85579 Neubiberg, Germany

© 2013 Infineon Technologies AG.
All Rights Reserved.

Visit us:
www.infineon.com

Order Number: B124-H9852-X-X-7600
Date: 11 / 2013

Attention please!

The information given in this document shall in no event be regarded as a guarantee of conditions or characteristics ("Beschaffenheitsgarantie"). With respect to any examples or hints given herein, any typical values stated herein and/or any information regarding the application of the device, Infineon Technologies hereby disclaims any and all warranties and liabilities of any kind, including without limitation warranties of non-infringement of intellectual property rights of any third party.

Information

For further information on technology, delivery terms and conditions and prices please contact your nearest Infineon Technologies Office (www.infineon.com).

Warnings

Due to technical requirements components may contain dangerous substances. For information on the types in question please contact your nearest Infineon Technologies Office. Infineon Technologies Components may only be used in life-support devices or systems with the express written approval of Infineon Technologies, if a failure of such components can reasonably be expected to cause the failure of that life-support device or system, or to affect the safety or effectiveness of that device or system. Life support devices or systems are intended to be implanted in the human body, or to support and/or maintain and sustain and/or protect human life. If they fail, it is reasonable to assume that the health of the user or other persons may be endangered.