

TC1724 – AUDO MAX family

Automotive 32-bit TriCore™ Microcontroller

The 32 Bit TriCore™ microcontroller TC1724 is one of the entry level derivatives of the AUDO MAX family. It provides enhanced microcontroller performance of up to 133MHz, 1.5MB embedded Flash and extensive SRAM of 152KB. Package is the easy-to-mount QFP-144 with exposed Pad to facilitate thermal management. For reduced system cost an embedded voltage controller (EVR) is implemented which generates I/O and core voltage internally. Another major focus was put on safety requirements. TC1724 offers a comprehensive set of safety features like e.g. Error Code Correction (ECC) for the full memory set (Flash and SRAM). Also SW will be made available to meet Safety requirements in accordance to our PRO-SIL™ safety standard. The comprehensive and consistent tool support known from earlier TriCore™ products will also be provided for TC1724.

Applications

- Low End Engines (e.g. 2cylinder/Multi-Point injection)
- Selective Catalytic Reduction
- Transmission (e.g. AMT/DCT)
- Hybrid and electric vehicle (e.g. Battery Management)
- Suspension systems
- Chassis Domain Controller

Execution performance

- High performance 32-bit super-scalar TriCore™ V1.3.1 CPU with 4 stage pipeline
 - up to 133MHz at full automotive temperature range
 - Superior real-time performance
 - Strong bit handling
 - Fully integrated DSP capabilities
 - Single precision floating point unit
- 32-bit Peripheral Control Processor with single cycle instruction (PCP2)
 - 32KByte on-chip SRAM

Main Features

- Memories:
 - 1.5MB embedded program flash with ECC
 - 64KByte data flash
 - 152KByte on-chip SRAM
 - 4KByte Data cache (configurable)
 - 8KByte Instruction cache (configurable)
- 16 DMA channels
- 1 General Purpose Timer Array
- 2 FlexRay™ channels (optional)
- 1 Micro Second bus interface (MSC)
- 2 asynchronous/synchronous serial interfaces (ASC)
- 4 high speed synchronous serial interfaces (SSC)
- 1 High-speed Micro Link Interface (MLI)
- 3 CAN nodes and 64 message objects
- 2 channel fast analog-to-digital converter
- 24 channel analog-to-digital converter (5/3.3V)
- On-chip debug support (OCDS)
- Dedicated emulation device chip (ED) for multicore debugging, tracing and calibration
- Low Bill-of-Material Features
- Extensive set of safety features
- Full automotive temperature range -40° to +125°C
- QFP-144 Package

TC1724 - AUDDO MAX family

Automotive 32-bit TriCore™ Microcontroller

System Diagram

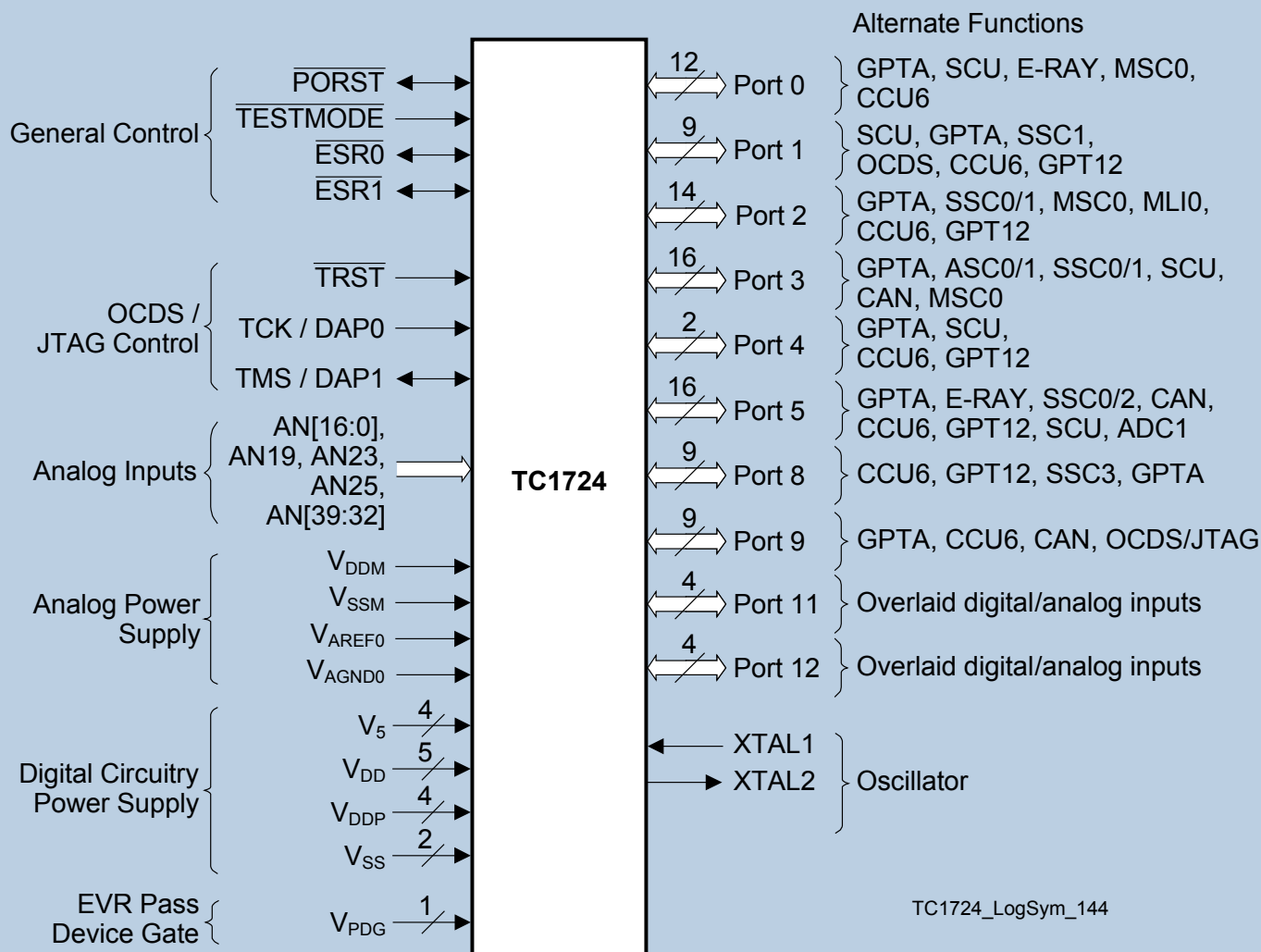

Product Summary

Type	eFlash	Data Flash	Frequency	SRAM	Package	Temp. Range
SAK-TC1724F*-192F133H	1.5MB	64KB**	133MHz	152KB*	PG-QFP-144	-40...+125°C
SAK-TC1724N-128F80H	1MB	64KB**	80MHz	152KB*	PG-QFP-144	-40...+125°C

* F stands for FlexRay included

**EEPROM emulation (up to 60k w/e cycles)

Published by
Infineon Technologies AG
85579 Neubiberg, Germany

© 2012 Infineon Technologies AG.
All Rights Reserved.

Visit us:
www.infineon.com

Order Number: B158-H9556-G1-X-7600
Date: 02 / 2012

ATTENTION PLEASE!

The information given in this document shall in no event be regarded as a guarantee of conditions or characteristics ("Beschaffenheitsgarantie"). With respect to any examples or hints given herein, any typical values stated herein and/or any information regarding the application of the device, Infineon Technologies hereby disclaims any and all warranties and liabilities of any kind, including without limitation warranties of non-infringement of intellectual property rights of any third party.

INFORMATION

For further information on technology, delivery terms and conditions and prices please contact your nearest Infineon Technologies Office (www.infineon.com).

WARNINGS

Due to technical requirements components may contain dangerous substances. For information on the types in question please contact your nearest Infineon Technologies Office. Infineon Technologies Components may only be used in life-support devices or systems with the express written approval of Infineon Technologies, if a failure of such components can reasonably be expected to cause the failure of that life-support device or system, or to affect the safety or effectiveness of that device or system. Life support devices or systems are intended to be implanted in the human body, or to support and/or maintain and sustain and/or protect human life. If they fail, it is reasonable to assume that the health of the user or other persons may be endangered.