

## Package Outline

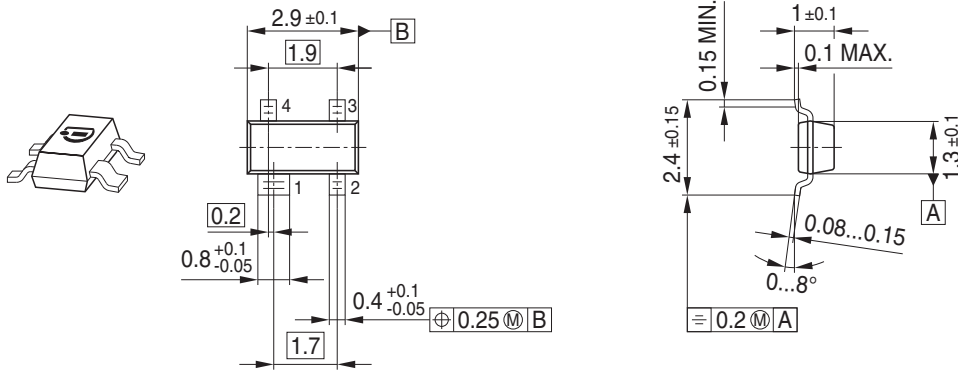

## Foot Print

Soldering Type: Reflow Soldering

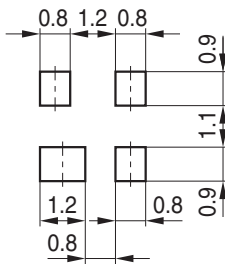

Soldering Type: Wave Soldering

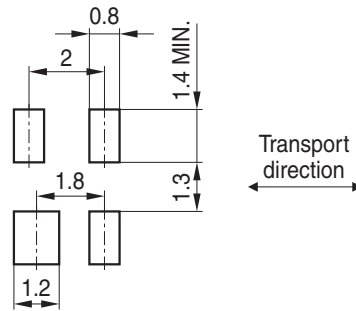

## Marking Layout (Example)

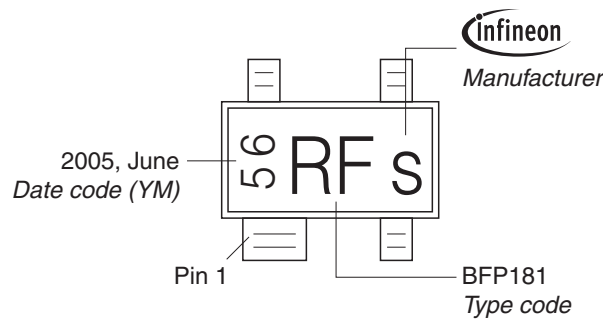

## Tape and Reel

Reel  $\varnothing$ 180 mm: 3.000 Pieces/Reel  
 Reels/Box: 1 x 3.000  
 Reels/Box: 10 x 3.000

Reel  $\varnothing$ 330 mm: 10.000 Pieces/Reel  
 Reels/Box: 1 x 10.000

