



www.infineon.com

Packing



Never stop thinking

Edition 2006-08

**Published by
Infineon Technologies AG
81726 Munich, Germany**

**© Infineon Technologies AG 2006.
All Rights Reserved.**

Legal Disclaimer

The information given in this document shall in no event be regarded as a guarantee of conditions or characteristics ("Beschaffenhheitsgarantie"). With respect to any examples or hints given herein, any typical values stated herein and/or any information regarding the application of the device, Infineon Technologies hereby disclaims any and all warranties and liabilities of any kind, including without limitation warranties of non-infringement of intellectual property rights of any third party.

Information

For further information on technology, delivery terms and conditions and prices please contact your nearest Infineon Technologies Office (www.infineon.com).

Warnings

Due to technical requirements components may contain dangerous substances. For information on the types in question please contact your nearest Infineon Technologies Office.

Infineon Technologies Components may only be used in life-support devices or systems with the express written approval of Infineon Technologies, if a failure of such components can reasonably be expected to cause the failure of that life-support device or system, or to affect the safety or effectiveness of that device or system. Life support devices or systems are intended to be implanted in the human body, or to support and/or maintain and sustain and/or protect human life. If they fail, it is reasonable to assume that the health of the user or other persons may be endangered.

1	Introduction	4
2	Sorts of Packing	4
2.1	Tape & Reel	4
2.2	Tube	5
2.3	Tray	6
2.4	Supplementary Dry-Pack	7
2.5	Boxes	7
3	Tape and Reel	8
3.1	Tape	8
3.2	Ammopack	12
3.3	Radial Tape	14
4	Tube	16
5	Trays	17
5.1	Bakable Tray	17
5.2	Blister Tray	19
6	Bulk Material	21
7	Supplementary Dry-Pack	22

1 Introduction

Infineon packing methods and materials are designed based on the following considerations

- Protection against mechanical damage caused by handling and arising during shipment to the customer
- Protection against environmental influences such as moisture
- Protection against electrical damage caused by charging or discharging (ESD = Electro-Static Discharge)
- Sensible handling on the part of the customer (such as, for example, processing using pick-and-place machines)

2 Sorts of Packing

2.1 Tape & Reel

- DIN IEC 60 286-3

The components are placed on a plastic tape (carrier tape) made of polystyrene or polycarbonate, with correspondingly shaped recesses in its surface, which is then sealed with a cover tape (transparent foil). The tape is wound on to a reel, and supplied in a cardboard box (resembling a pizza box). There are now also larger boxes, including the so-called "Big-Box", which can accommodate up to 10 reels.

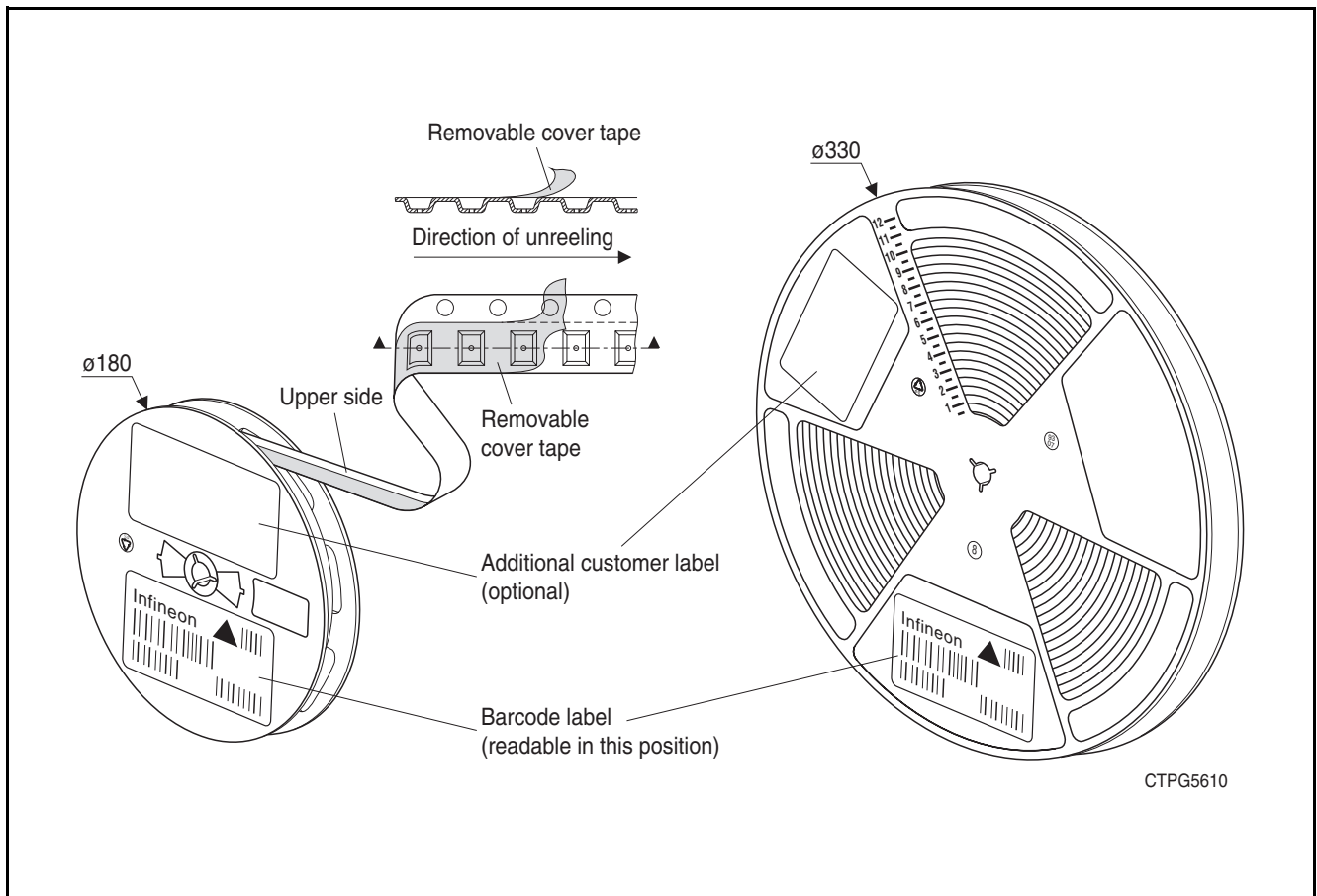

Figure 1 Tape & Reel
 \varnothing Reel 180 mm and 330 mm

2.2 Tube

- DIN IEC 60 286-4

In this case, the components are inserted into a PVC tube of appropriate cross sectional shape and standard length (528 mm₂). It is open on both sides and after filling is sealed using stoppers or pins. A number of tubes in one box form a packing unit.

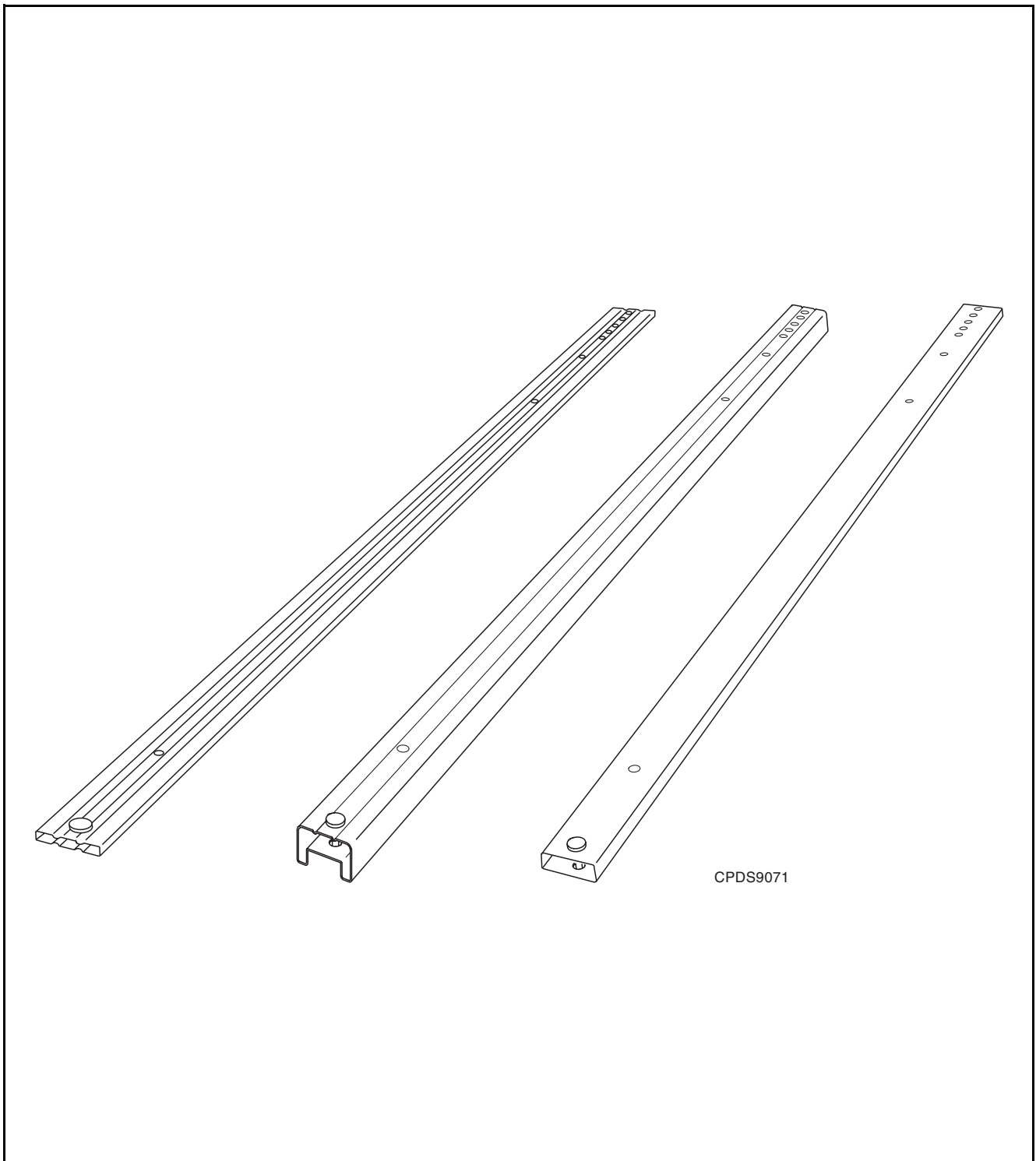

Figure 2 Tube

2.3 Tray

- DIN IEC 60 286-5

Here, the components are placed in rows in special compartmentalized plastic trays. One or more such trays laid one on top of the other here make up a packing unit.

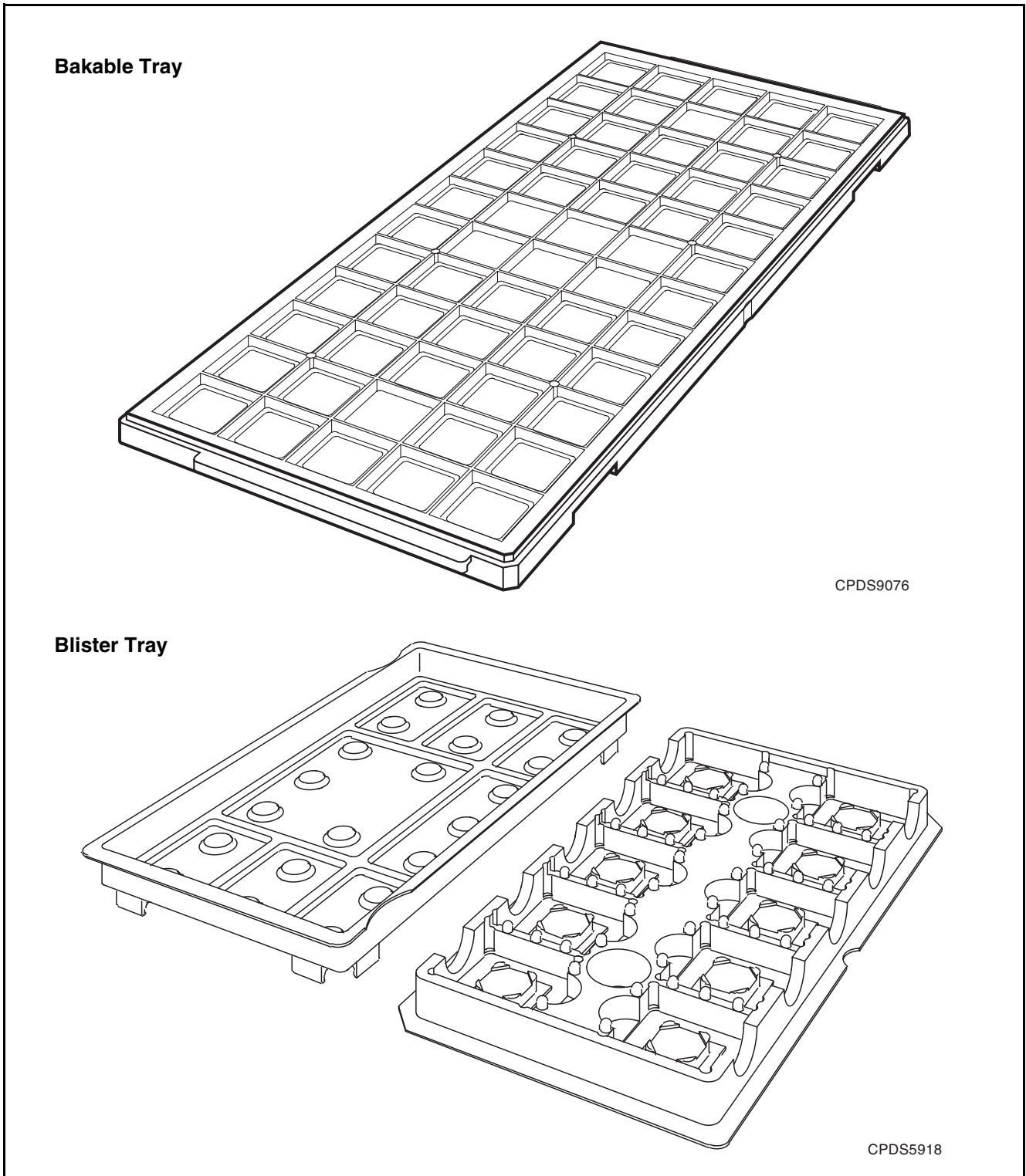

Figure 3 Tray's

2.4 Supplementary Dry-Pack

- JEDEC-STD-033B

Prior to packing, the components are heated to 125° C, for example, over a period of 24 hours, and then vacuum-sealed in a bag made of composite aluminum-plastic material. A desiccant is included in the packaging to remove residual moisture and soak up moisture penetrating the packaging during storage. An accompanying moisture indicator card shows the relative humidity level as a means of control.

2.5 Boxes

For each type of packing, there is an appropriate, correctly proportioned box or outer pack.

Each outer pack also receives a product label, on which all the important data is printed, in the form of a barcode and plain text (BPL = Barcode Product Label). After undergoing quality control, the boxes are sealed with an Infineon packing label.

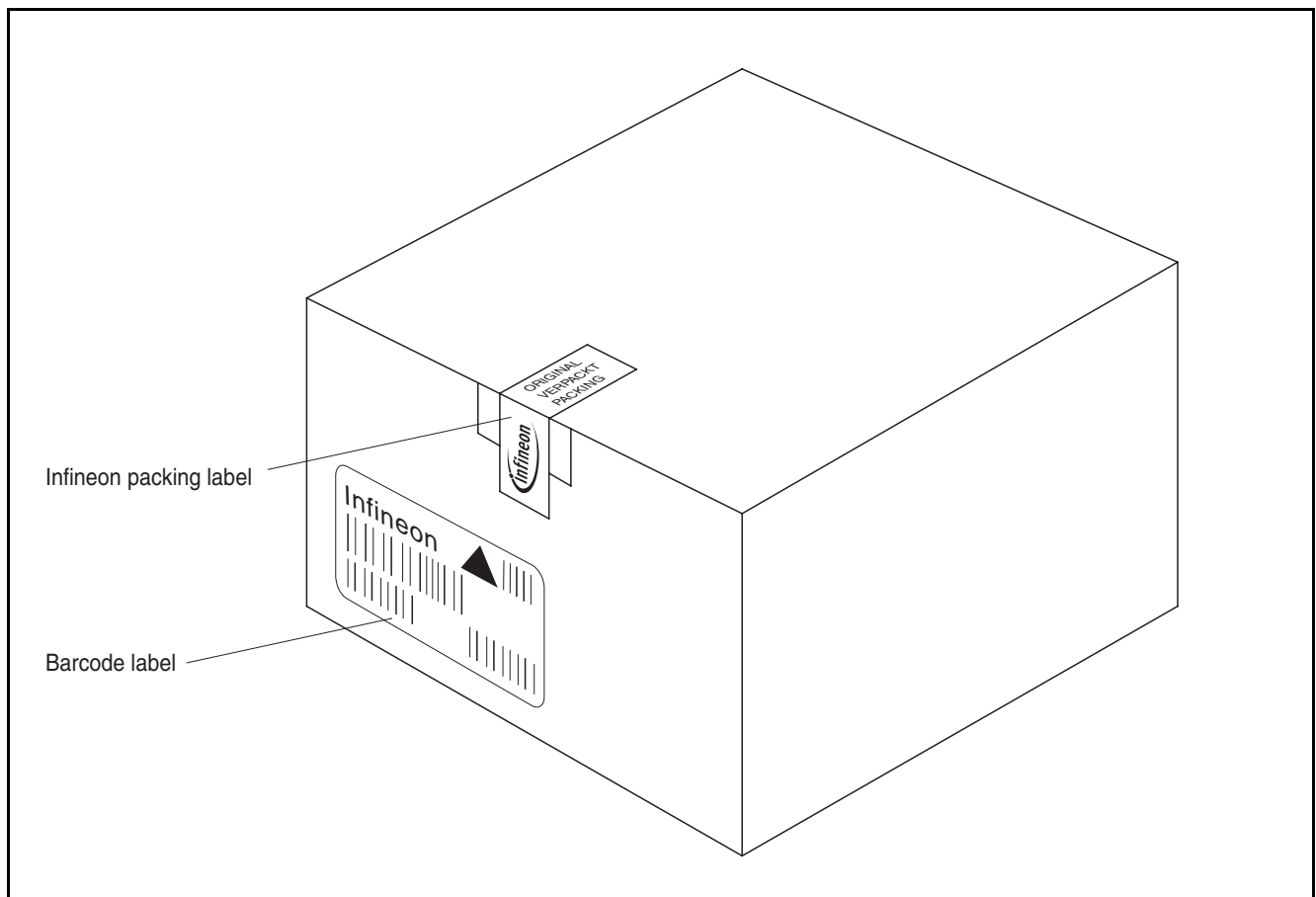

Figure 4 Box

Please consult your nearest Infineon semiconductor solder offices (see list of addresses) if you have any queries regarding the packaging units or multiple use.

Subject to change in the light of the new Packaging Act.

3 Tape and Reel

3.1 Tape

- DIN IEC 60 286-3

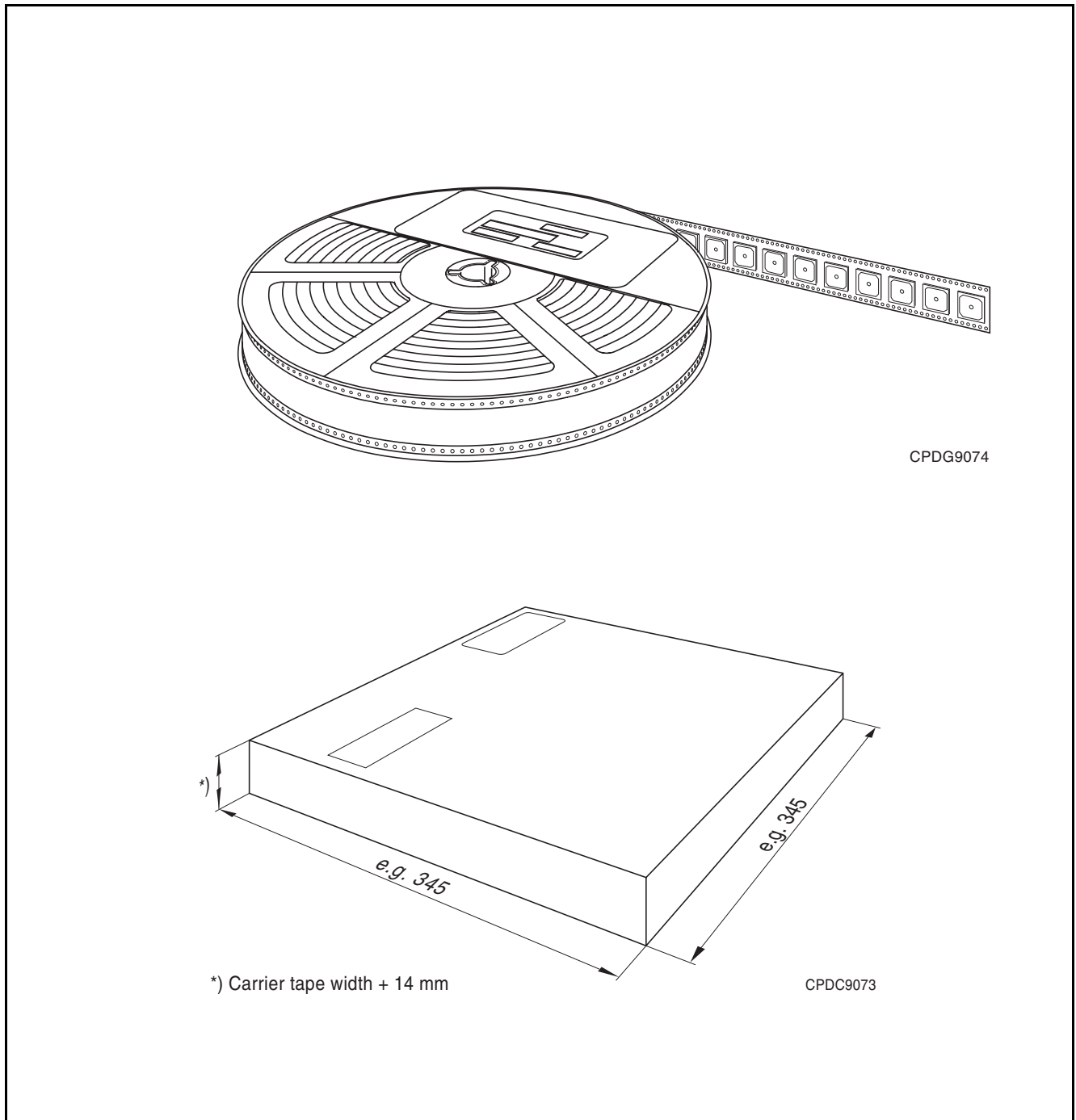

Figure 5 Packing for Tape & Reel¹⁾

1) All dimensions in mm

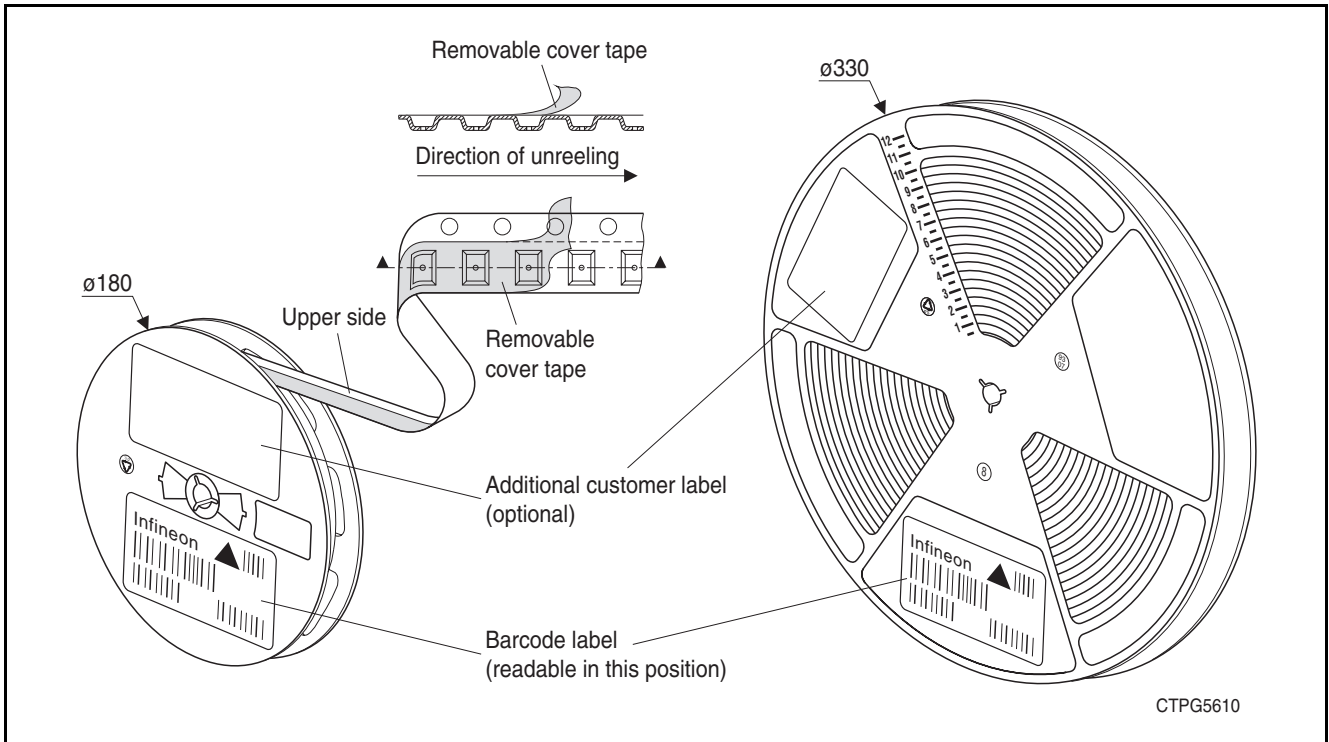

Figure 6 ø Reel 180 mm and 330 mm
Carrier tape width: 8, 12, 16 [mm]

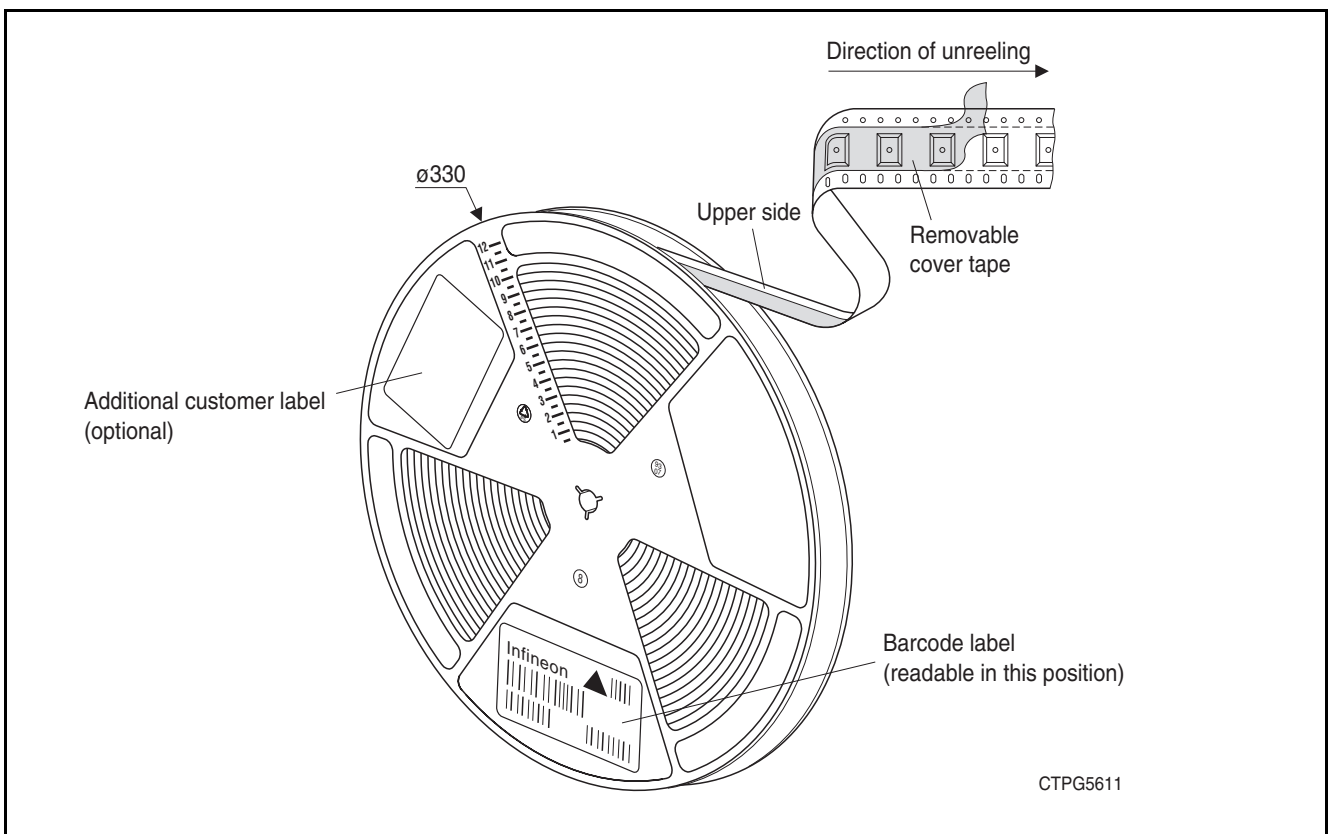

Figure 7 ø Reel 330 mm
Carrier tape width: 16, 24, 32, 44 [mm]

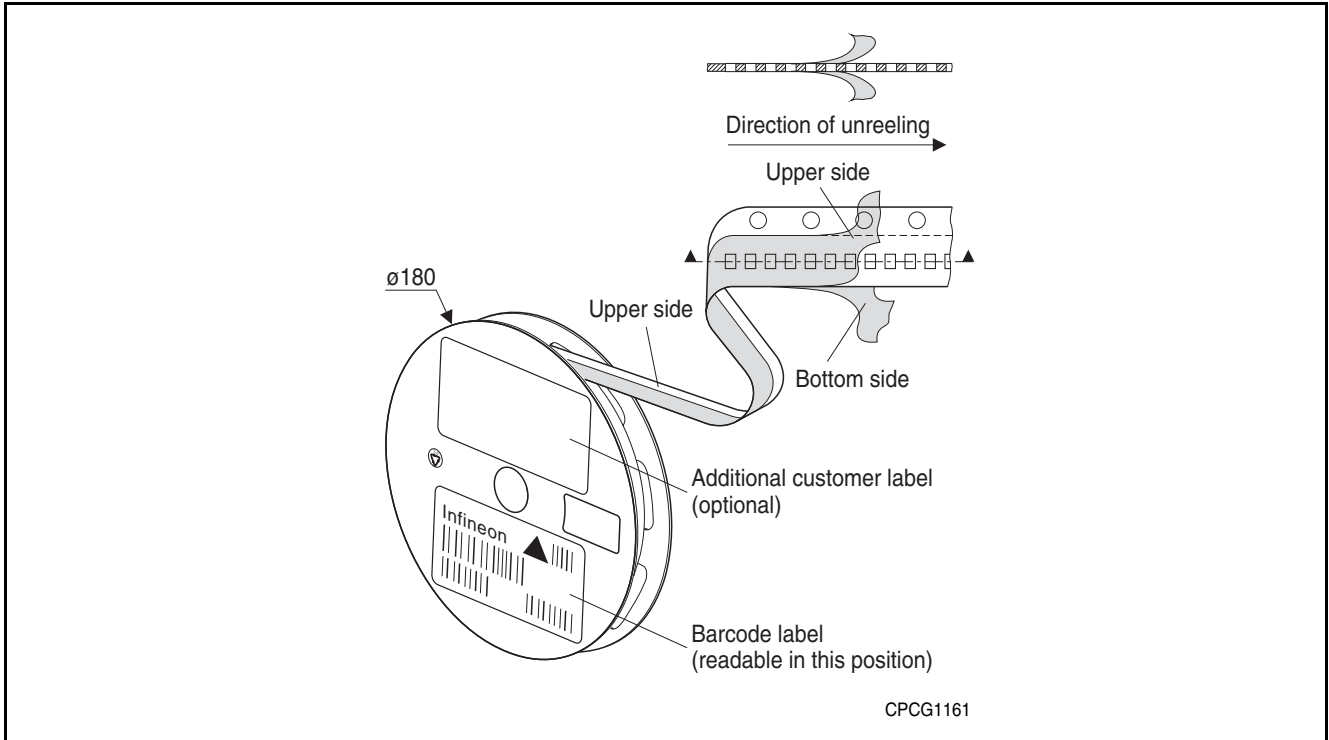

Figure 8 \varnothing Reel 180 mm
Embossed Carrier tape width: 8 [mm]

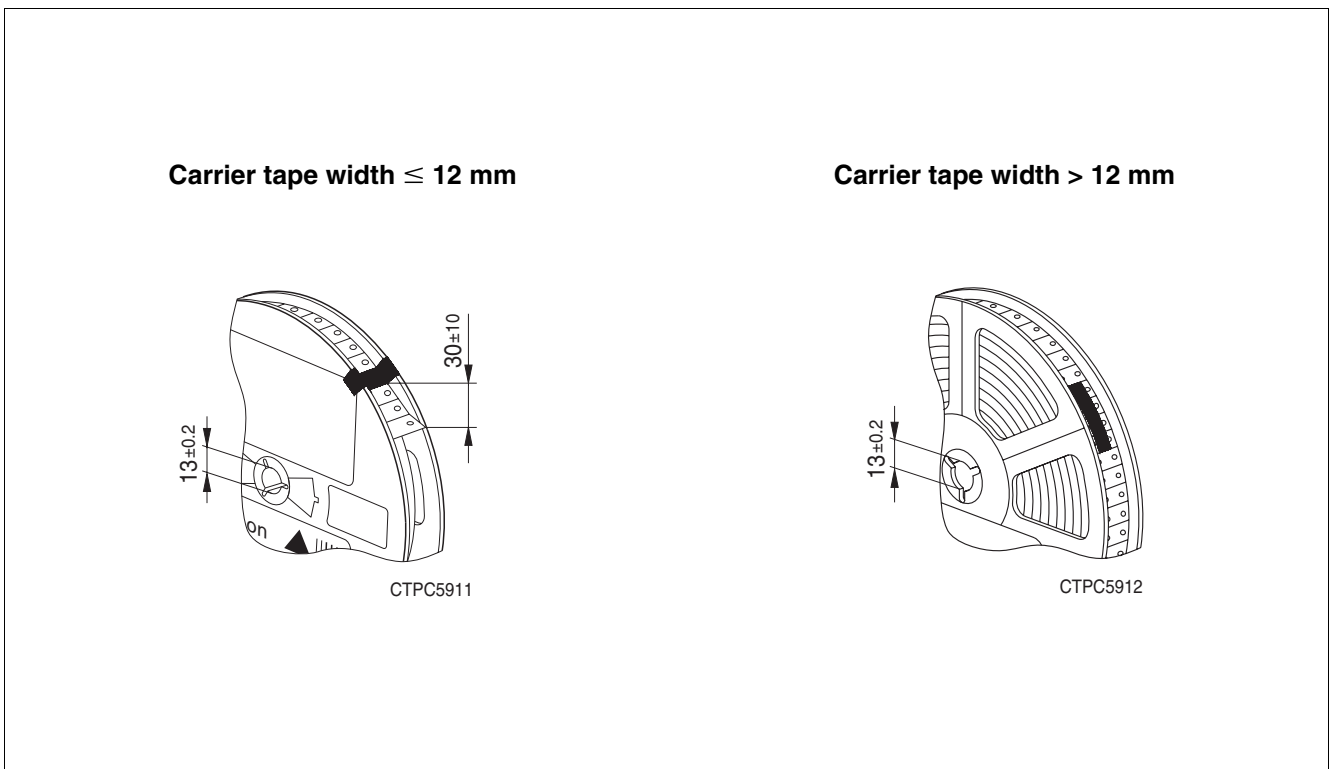

Figure 9 **Fixing on the Tape¹⁾**

1) All dimensions in mm

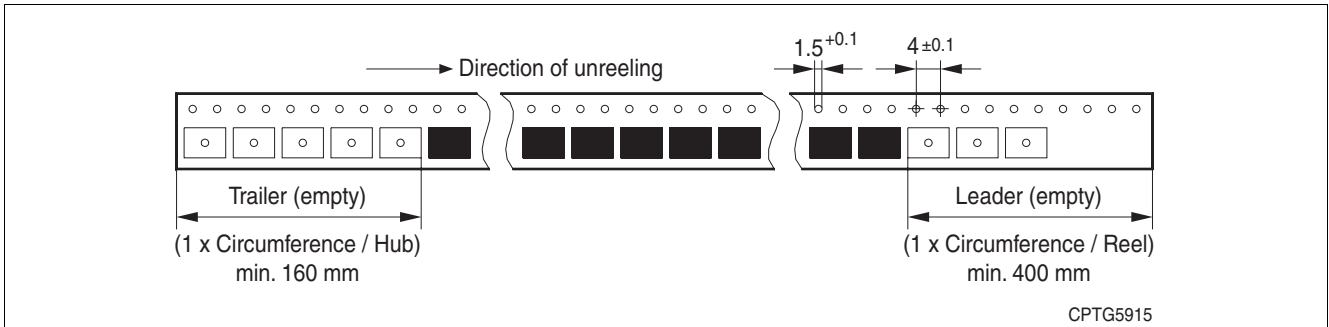

Figure 10 Direction of Unreeling¹⁾

There shall be a leader of 400 mm minimum of cover tape, which includes at least 100 mm of carrier tape with empty compartments. All the leader may consist of the carrier tape with empty compartments, sealed by cover tape.

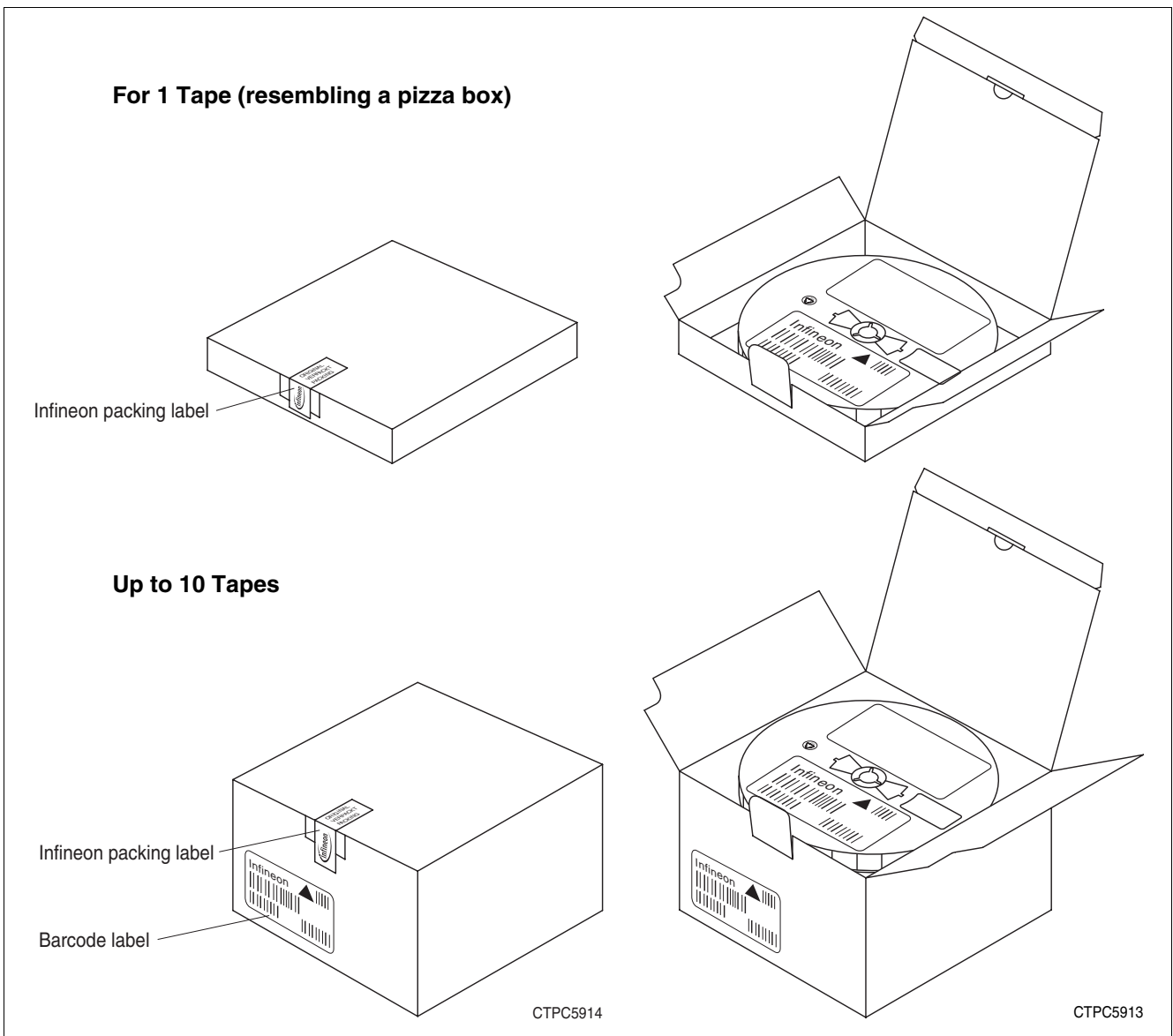

Figure 11 Labels and Boxes

1) All dimensions in mm

3.2 Ammopack

- Placed in Zigzag (DIN IEC 60 286-2)

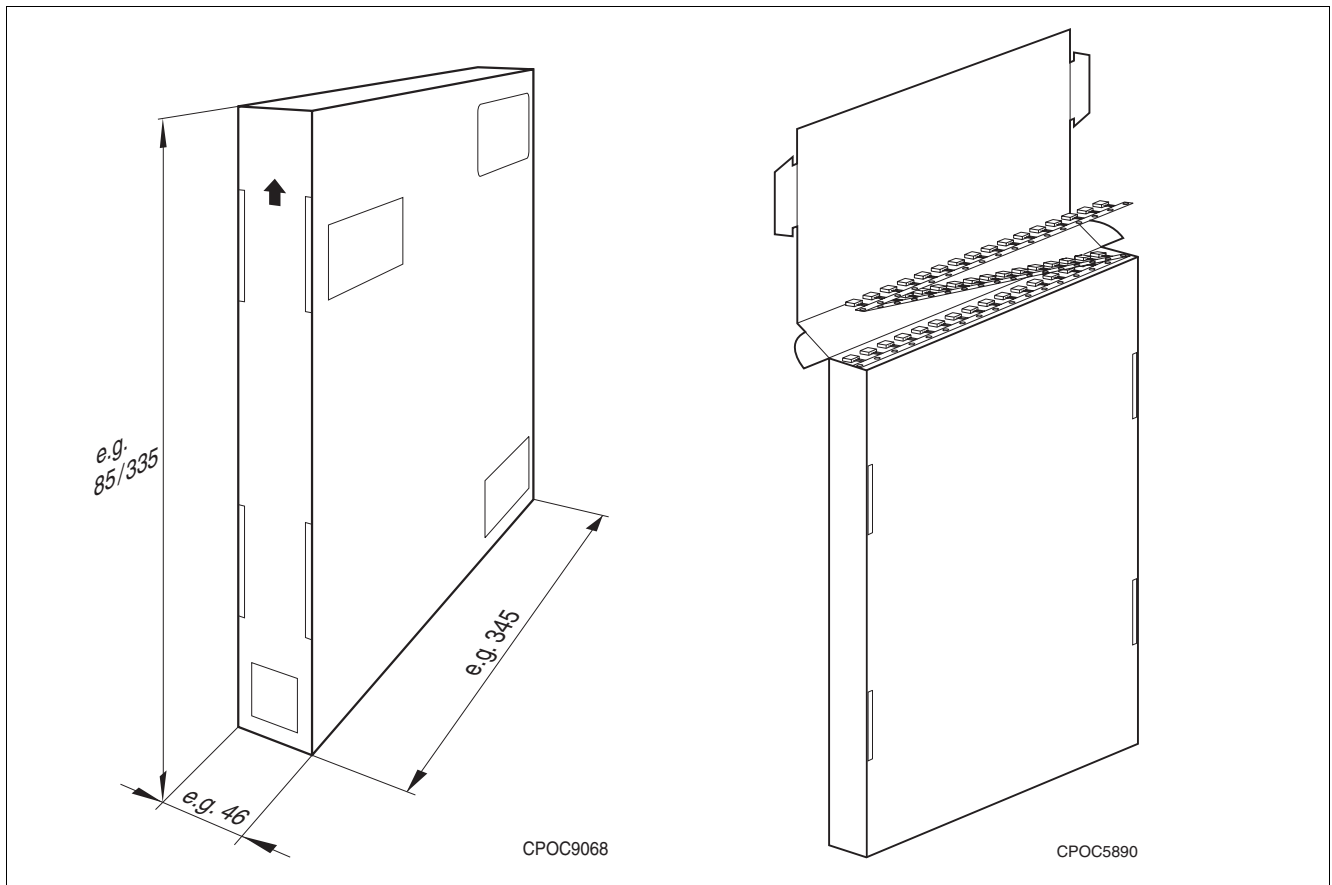

Figure 12 Up to 8.000 Components, Ammopack¹⁾

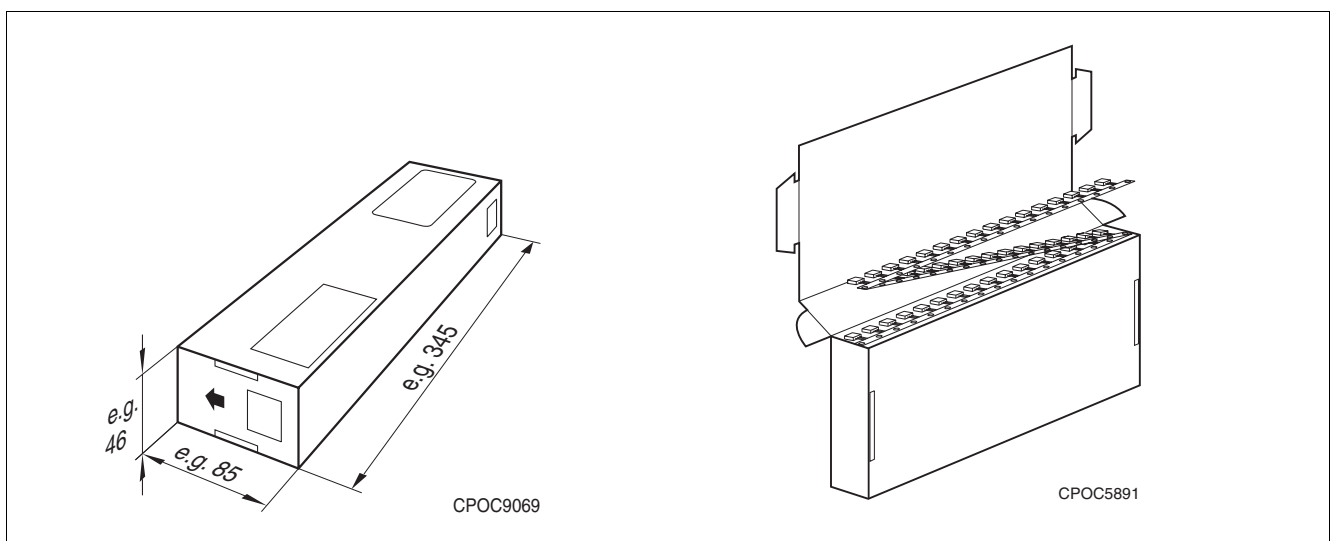

Figure 13 Up to 2.000 Components, Ammopack¹⁾

1) All dimensions in mm

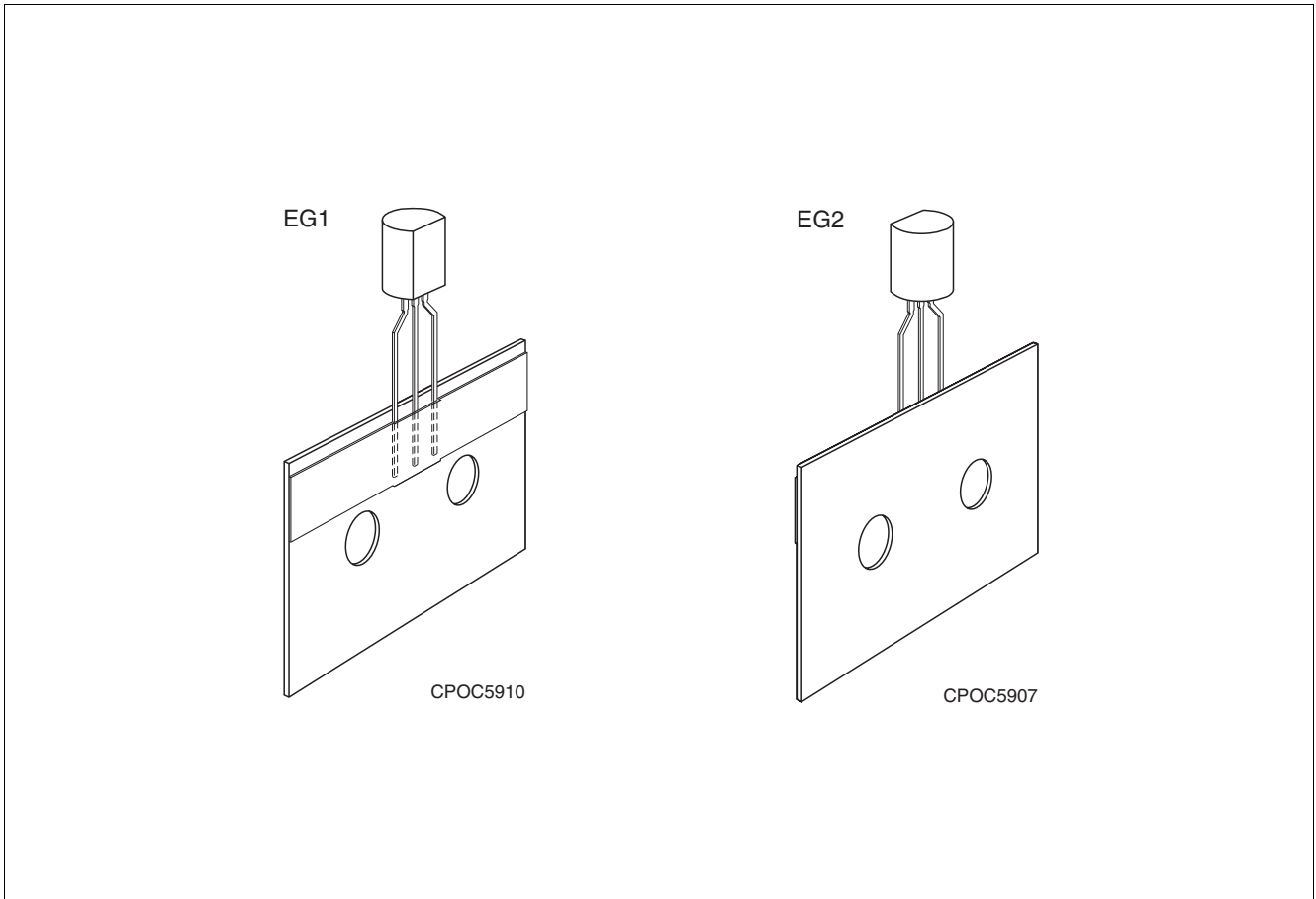

Figure 14 Supplementary Code for Ammopack

3.3 Radial Tape

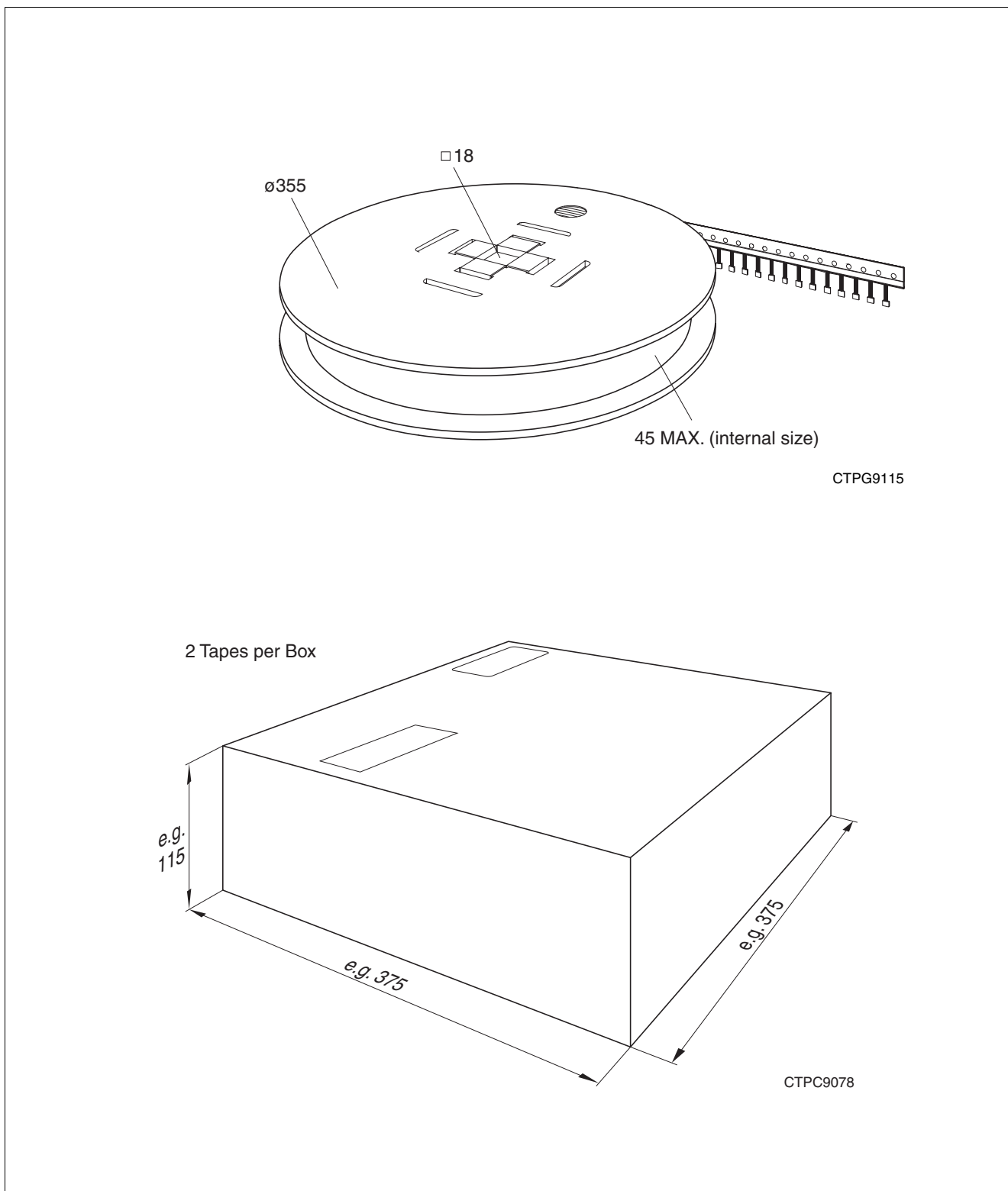

Figure 15 Packing for Radial Tape¹⁾

1) All dimensions in mm

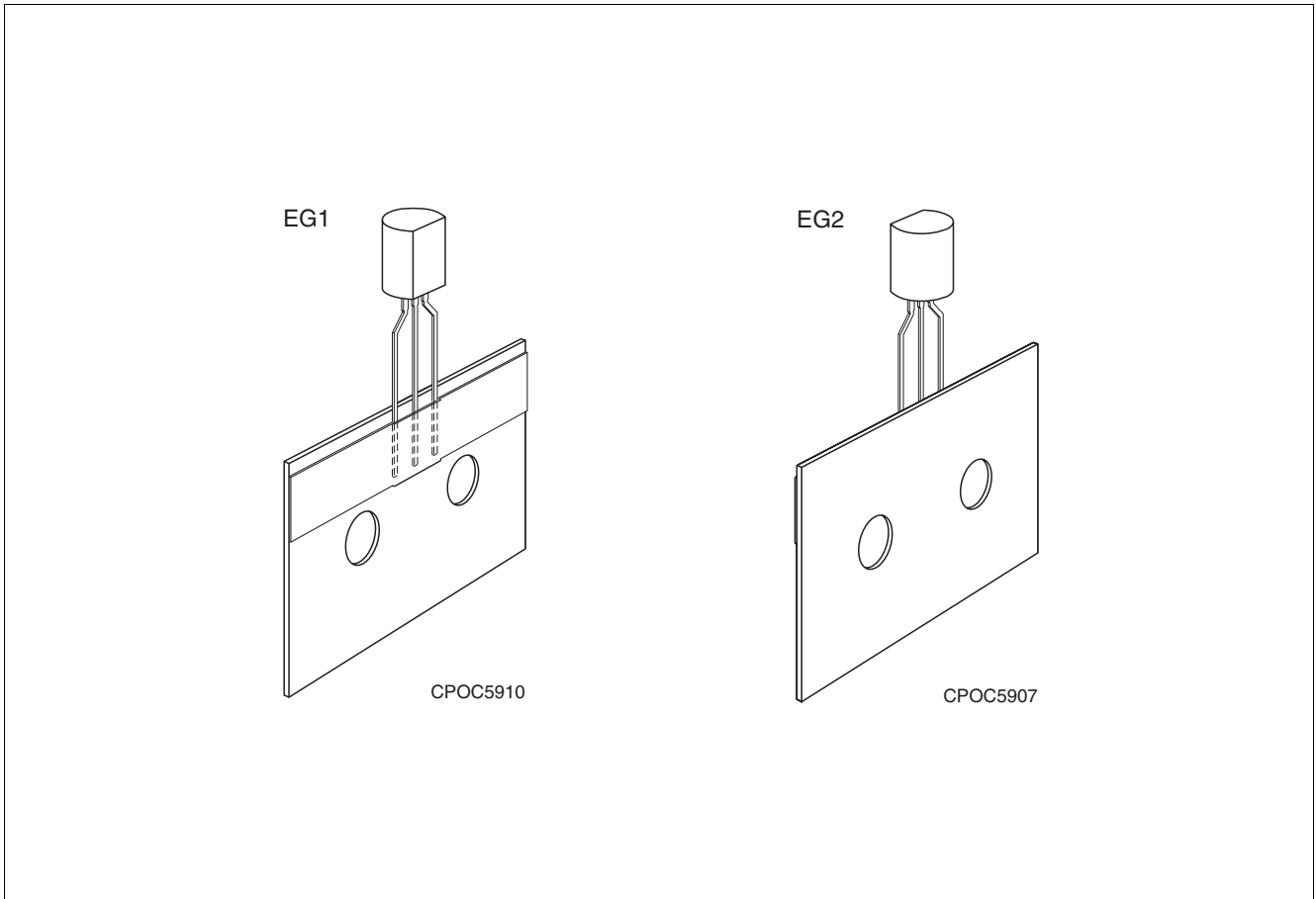

Figure 16 Supplementary Code for Radial Tape

4 Tube

- DIN IEC 60 286-4
- Standard Length: 528₂ mm; coated (unless stated to the contrary)

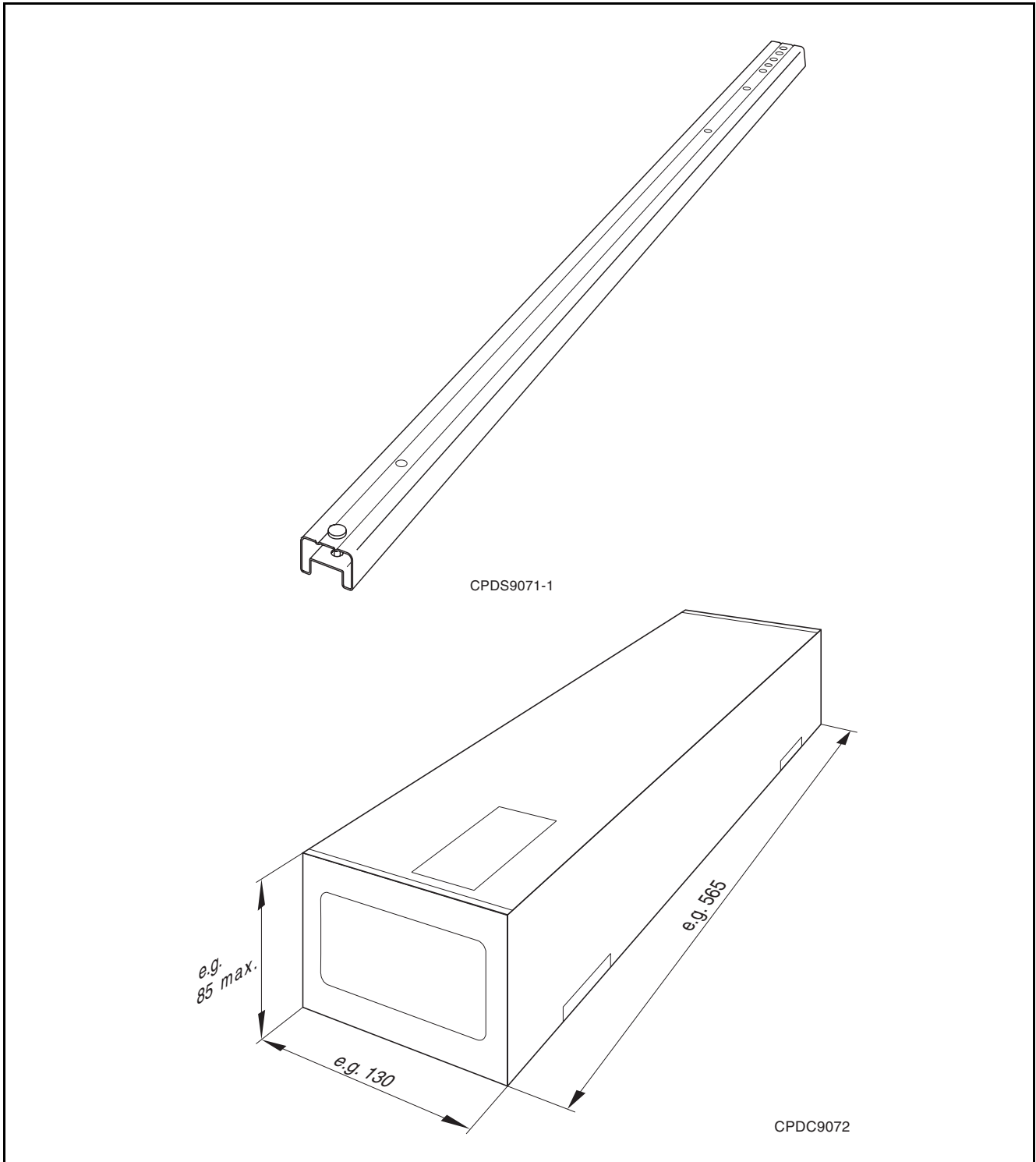

Figure 17 Packing for Tube¹⁾

1) All dimensions in mm

5 Trays

5.1 Bakable Tray

- Temperature max. 150°C (DIN IEC 60 286-5)

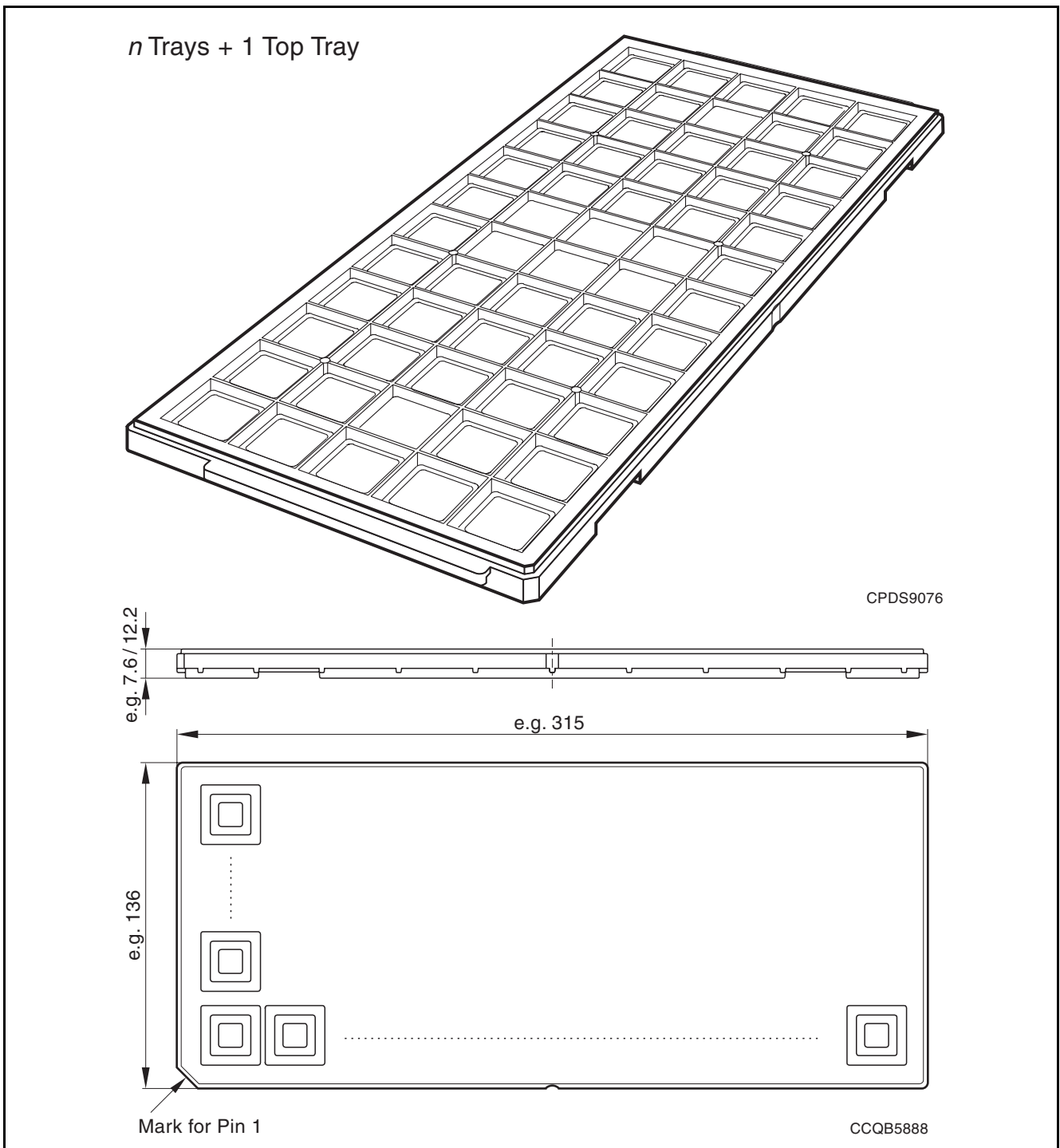

Figure 18 Bakable Tray¹⁾

1) All dimensions in mm

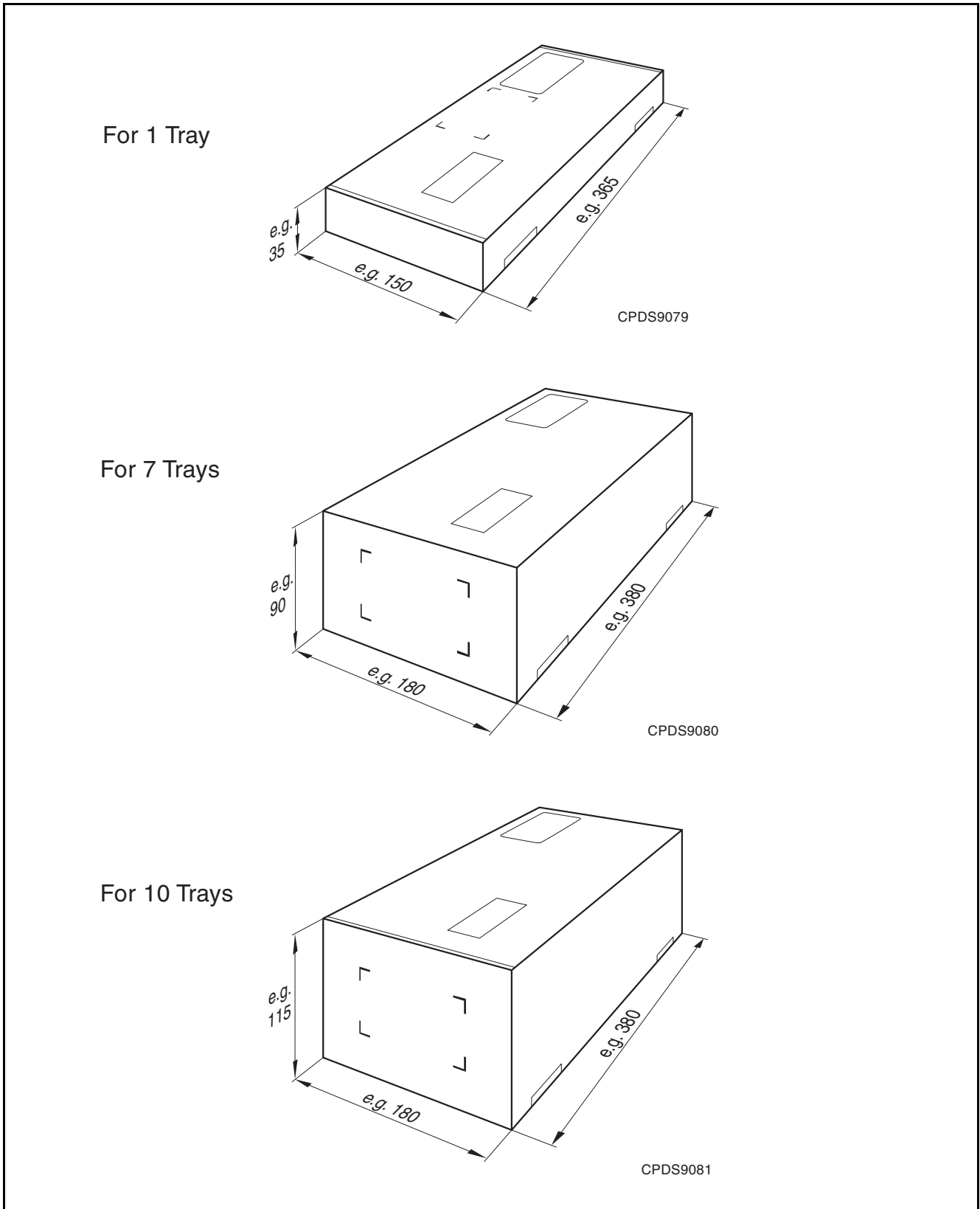

Figure 19 Type of Boxes for Bakable Tray¹⁾

1) All dimensions in mm

5.2 Blister Tray

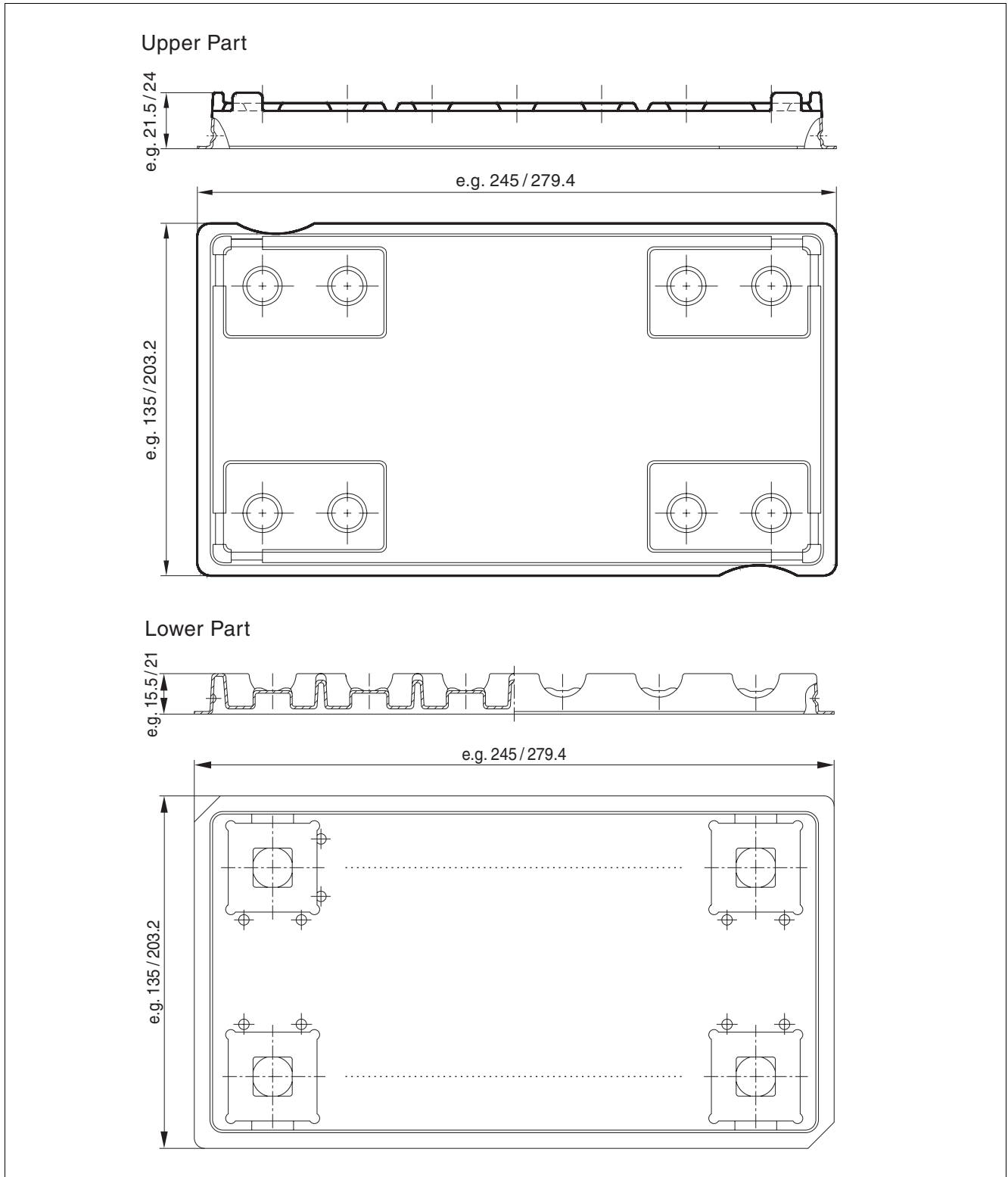

Figure 20 Blister Tray¹⁾

1) All dimensions in mm

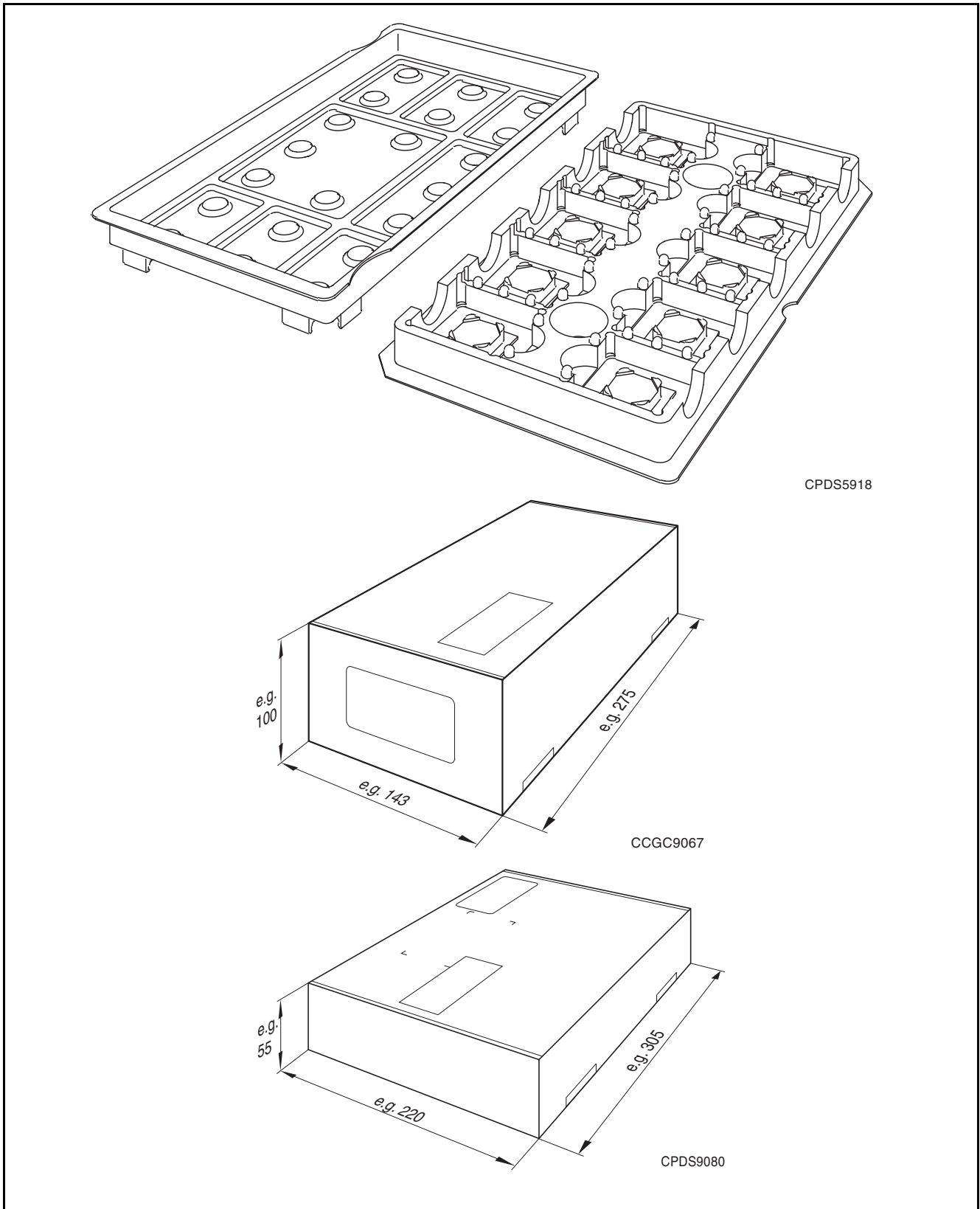

Figure 21 Packing for Blister Tray¹⁾

1) All dimensions in mm

6 Bulk Material

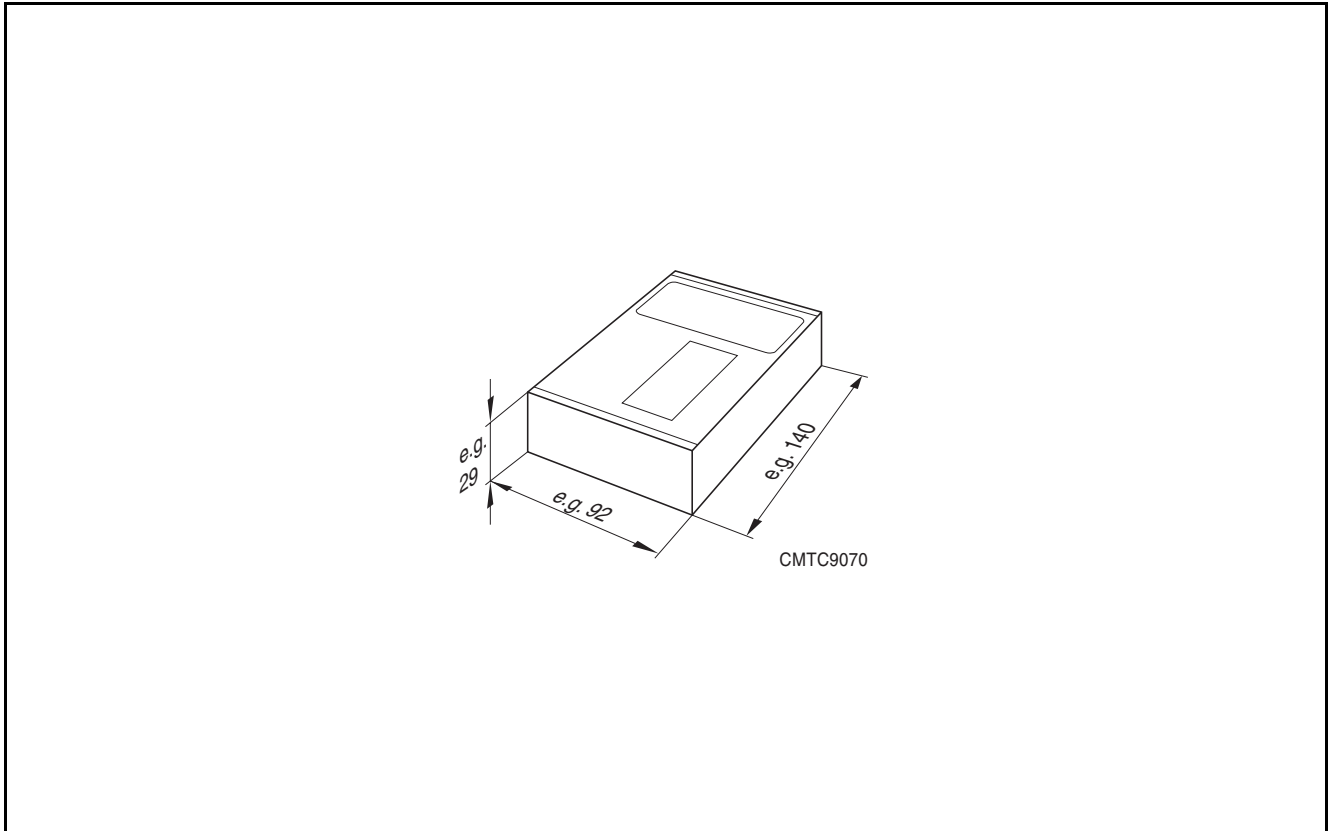

Figure 22 Bulk Material¹⁾

1) All dimensions in mm

7 Supplementary Dry-Pack

- JEDEC-STD-033B

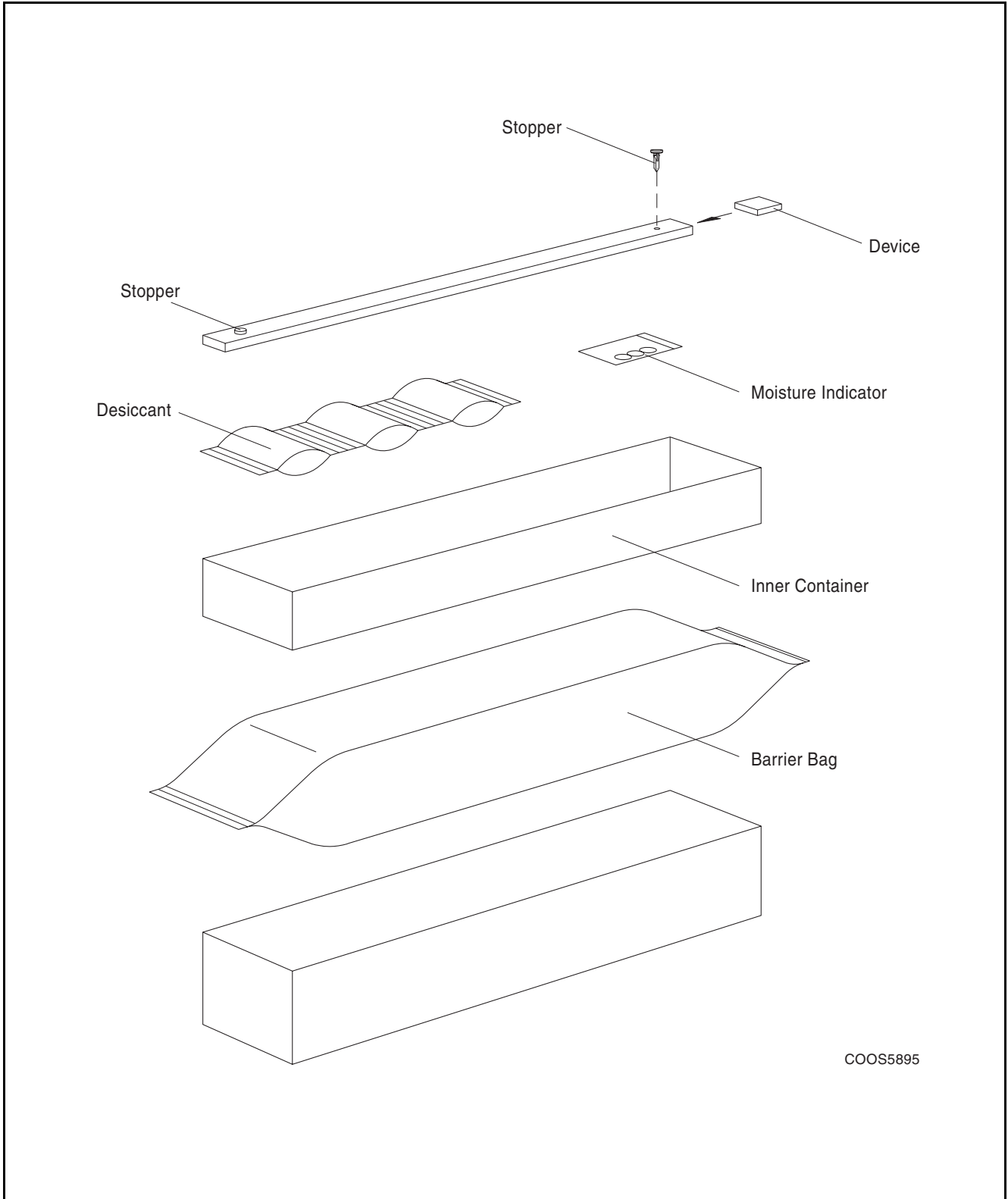

Figure 23 Example Dry-Pack e.g. for Tubes

www.infineon.com