

Package Outline

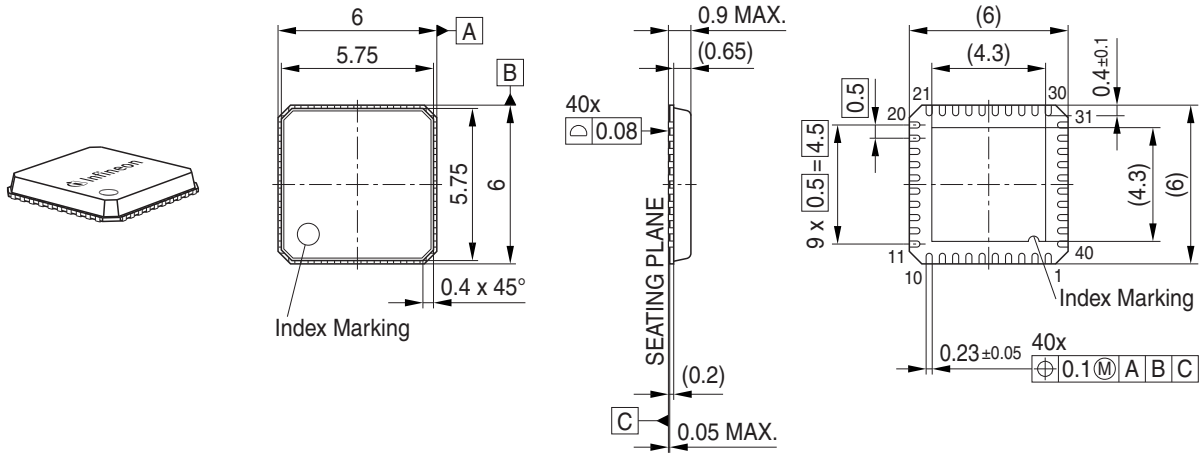

Foot Print

Soldering Type: Reflow Soldering

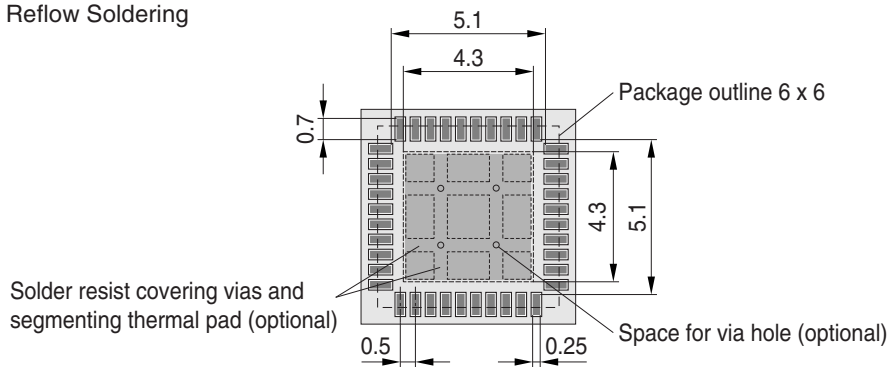

Marking Layout

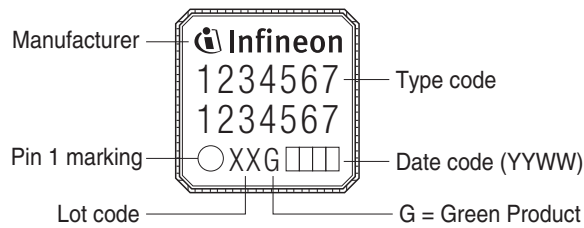

Tape and Reel

on demand