

## Package Outline

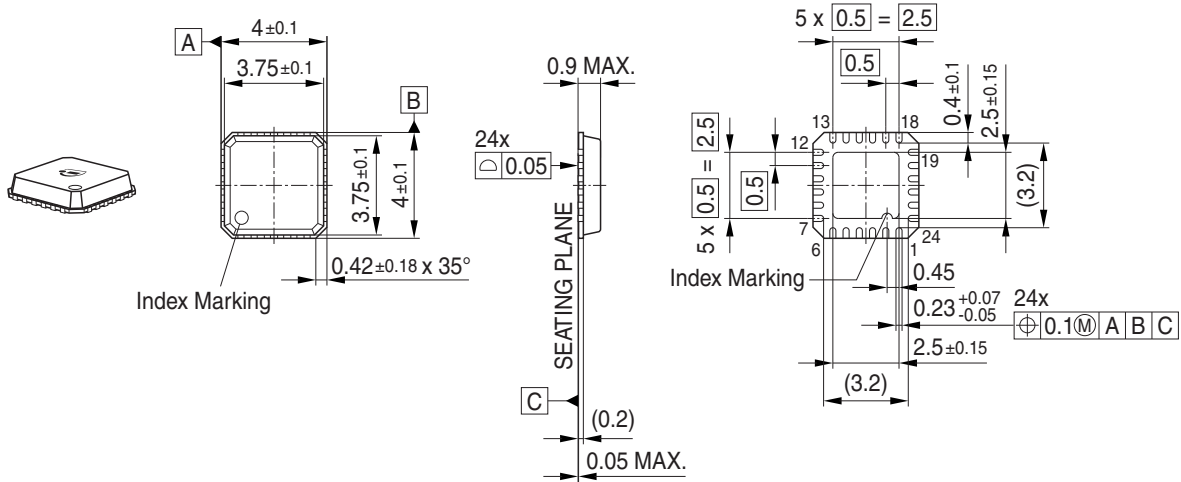

## Foot Print

Soldering Type: Reflow Soldering

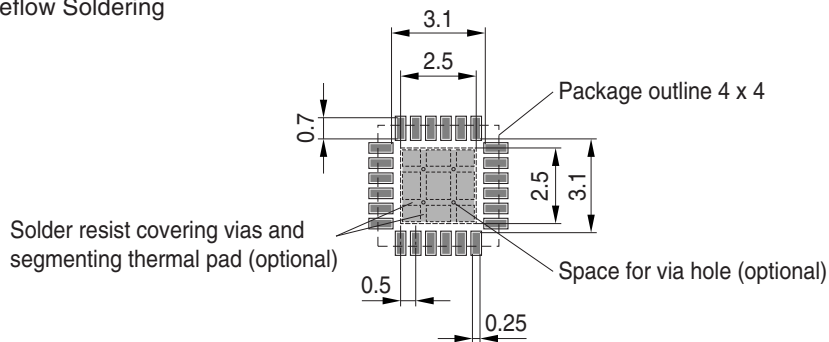

## Marking Layout

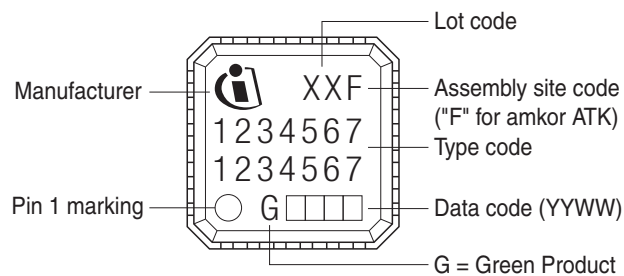

## Tape and Reel

Reel  $\phi 330 \text{ mm}$ : 6.000 Pieces/Reel

Reels/Box: 1

