

Package Outline

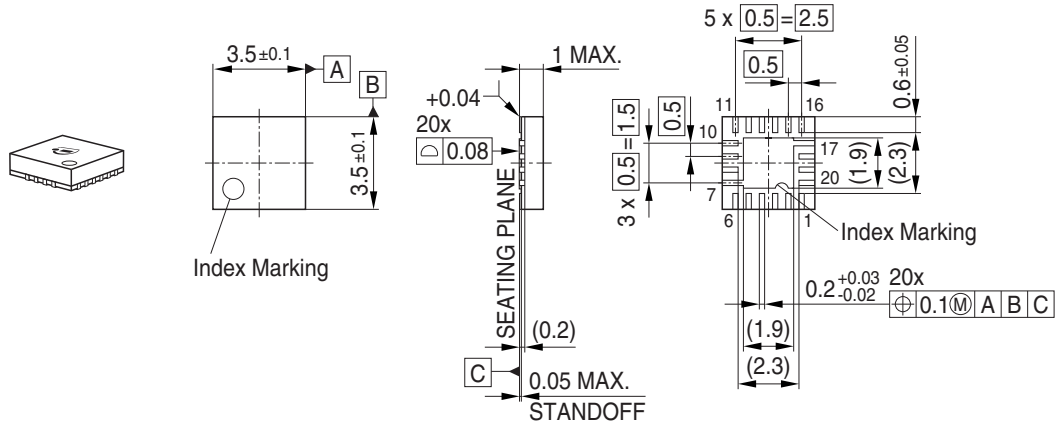

Foot Print

Soldering Type: Reflow Soldering

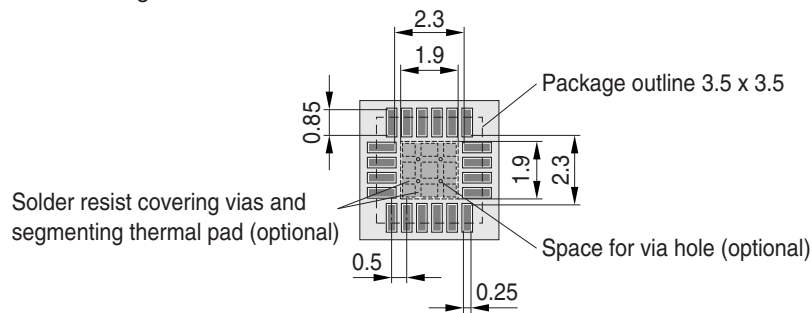

Marking Layout

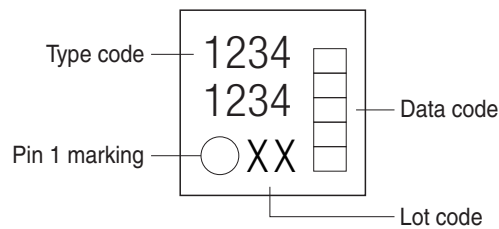

Tape and Reel

Reel ø330 mm: 4.000 Pieces/Reel
 Reels/Box: 1 x 4.000 = 4.000

