

Package Outline

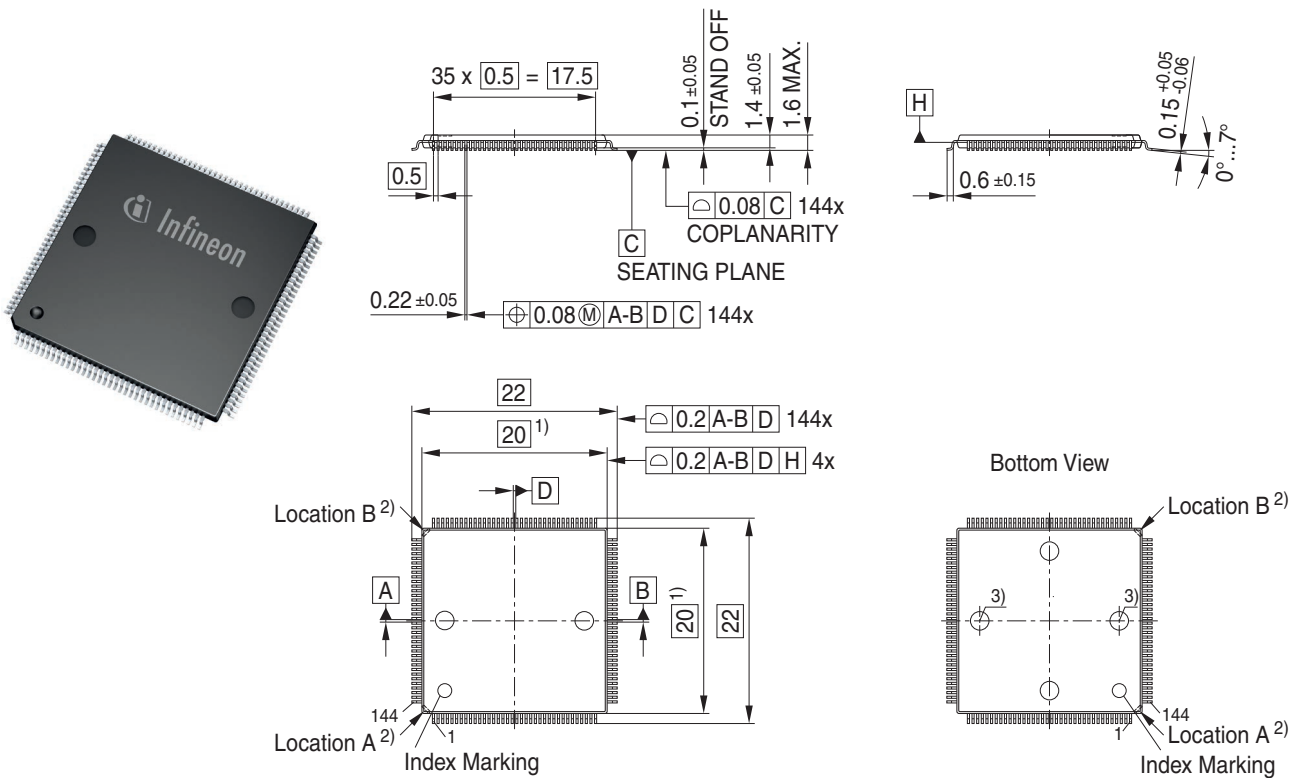

- 1) Does not include plastic or metal protrusion of 0.25 max. per side
- 2) PKG corner chamfer of 0.8 x 45° will be at Location A or Location B, defining by mold process.
- 3) This two ejector marks may be omitted depending on mold tool

Foot Print

Soldering Type: Reflow Soldering

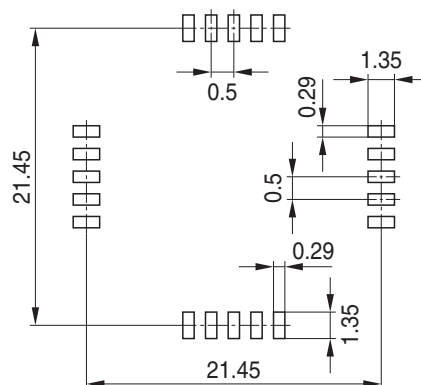

Marking Layout

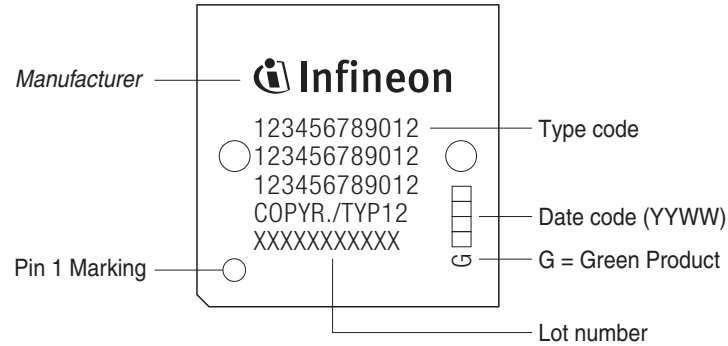

Tape and Reel (Dry)

Reel \varnothing 330 mm: 1.000 Pieces/Reel

Reels/Box: 1 x 1.000 = 1.000

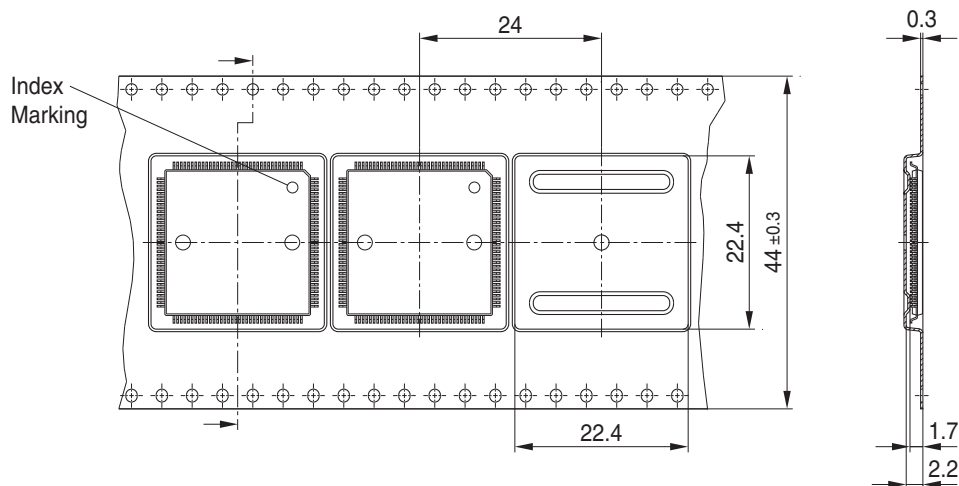

Bakable Tray (Dry)

Pieces/Tray: 60

Trays/Box: 6

