

Package Outline

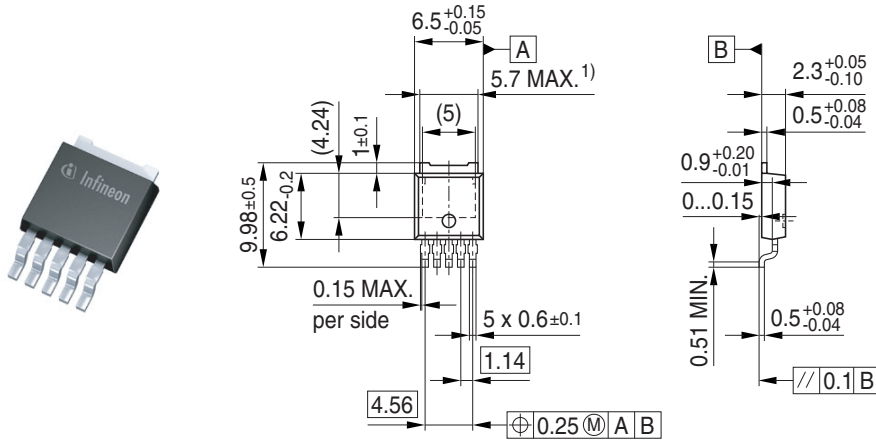

1) Includes mold flashes on each side.
All metal surfaces tin plated, except area of cut.

Foot Print

Soldering Type: Reflow Soldering

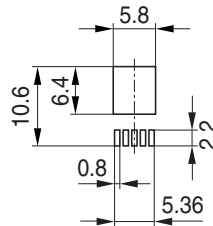

Marking Layout

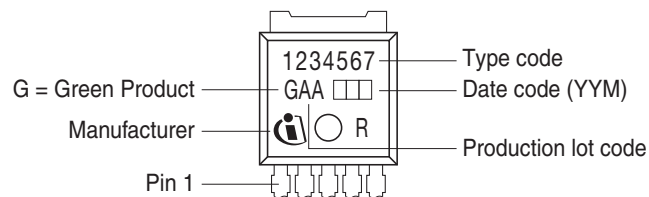

Tape and Reel

Reel \varnothing 330 mm: 2.500 Pieces/Reel
Reels/Box: 1

