

Package Outline

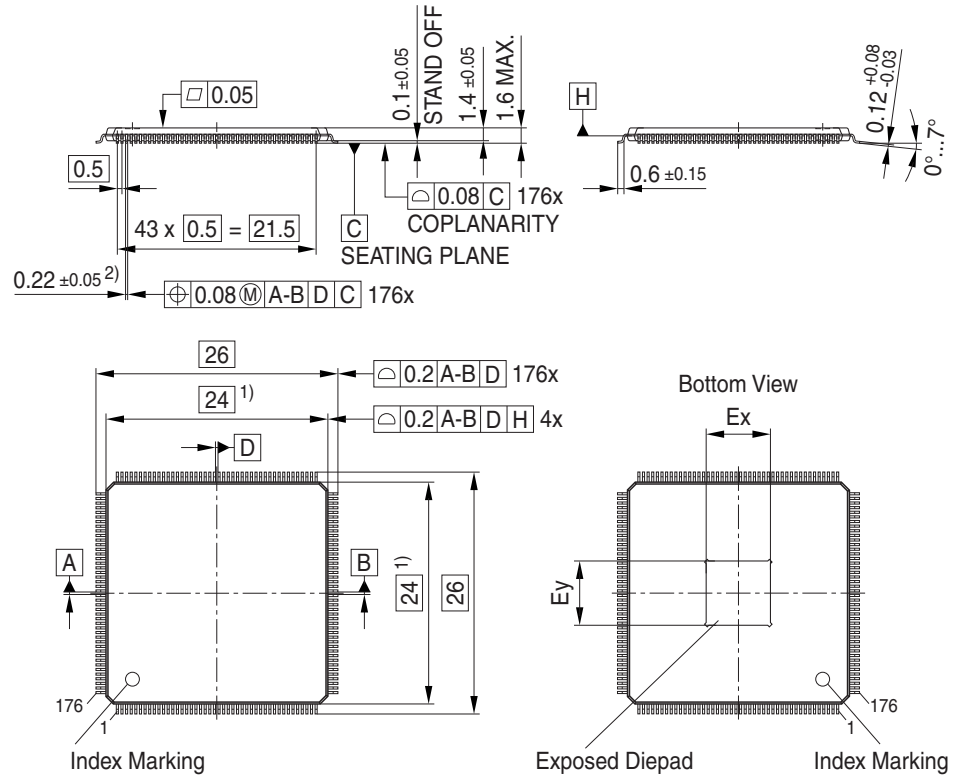

- 1) Does not include plastic or metal protrusion of 0.25 max. per side
- 2) Does not include dambar protrusion of 0.08 max. per side

Exposed Diepad Dimensions		
Leadframe	Ex	Ey
C66065-A5613-C001	9.78	11
C66065-A5613-C002	5.15	5.42

Foot Print

Soldering Type: Reflow Soldering

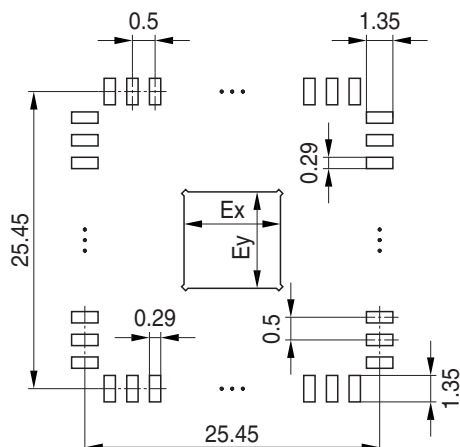

Exposed Diepad Dimensions		
Leadframe	Ex	Ey
C66065-A5613-C001	9.78	11
C66065-A5613-C002	5.15	5.42

Marking Layout

on demand

Tape and Reel

on demand