

Package Outline

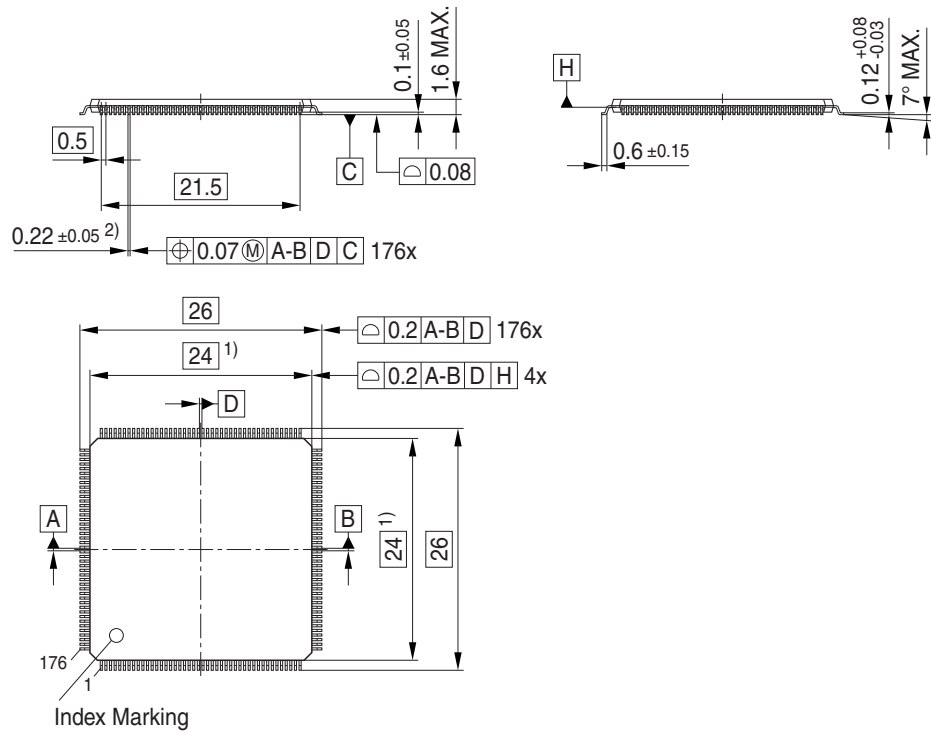

- 1) Does not include plastic or metal protrusion of 0.25 max. per side
- 2) Does not include dambar protrusion of 0.08 max. per side

Foot Print

Soldering Type: Reflow Soldering

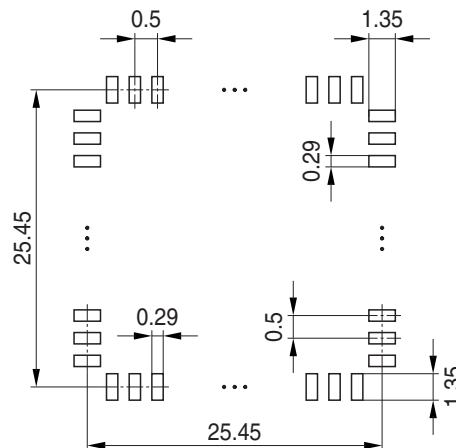

Marking Layout

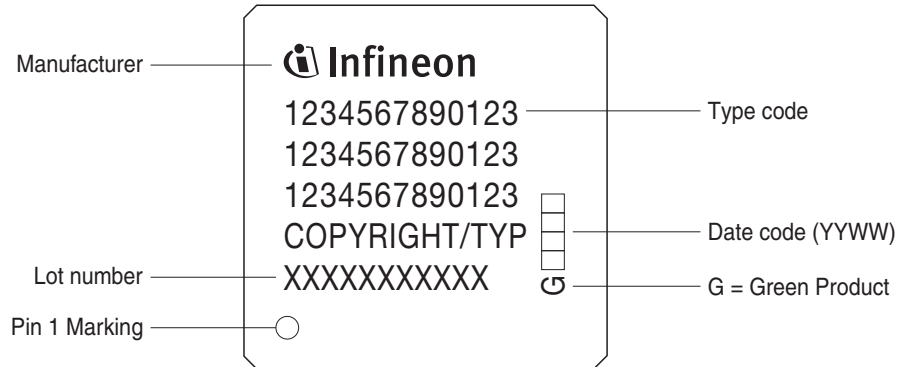

Tape and Reel

Reel ϕ 330 mm: 500 Pieces/Reel
Reels/Box: 1

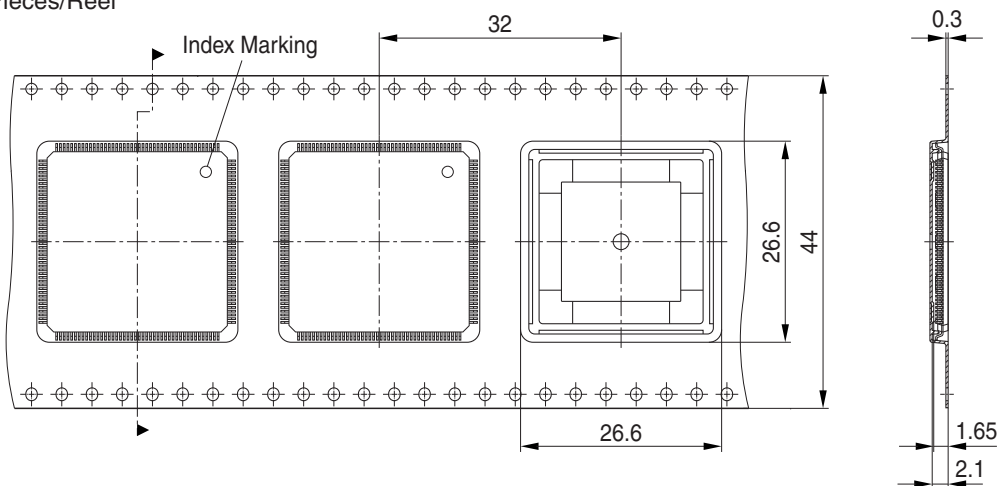

Bakable Tray

Pieces/Tray: 40
Trays/Box: 1; 6

