

## Package Outline

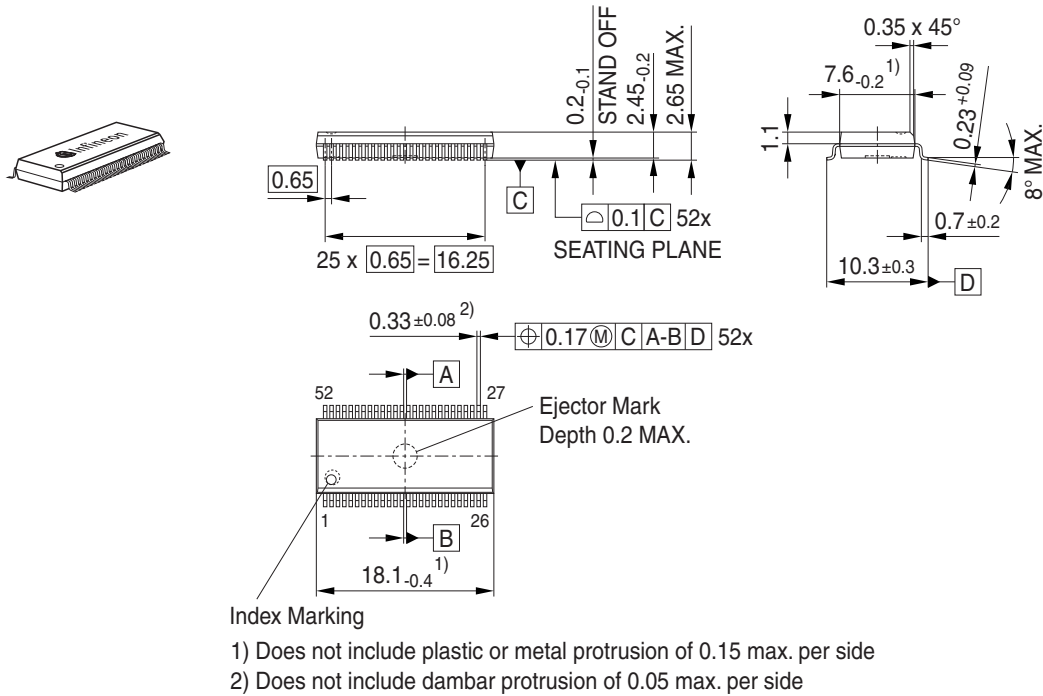

## Foot Print

Soldering Type: Reflow Soldering

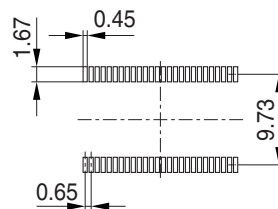

## Marking Layout

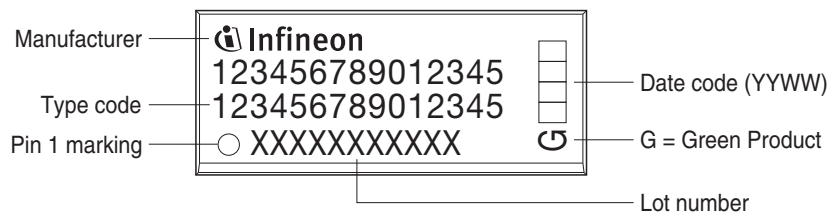

## Tape and Reel

Reel ø330 mm: 1.000 Pieces/Reel

