

Package Outline

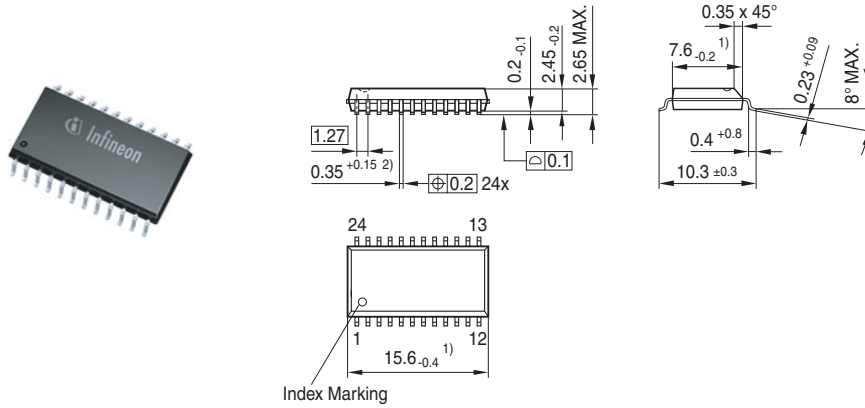

- 1) Does not include plastic or metal protrusion of 0.15 max. per side
- 2) Lead width can be 0.61 max. in dambar area

Foot Print

Soldering Type: Reflow Soldering

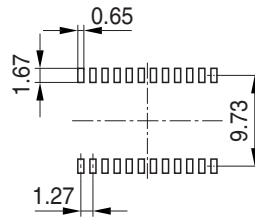

Marking Layout

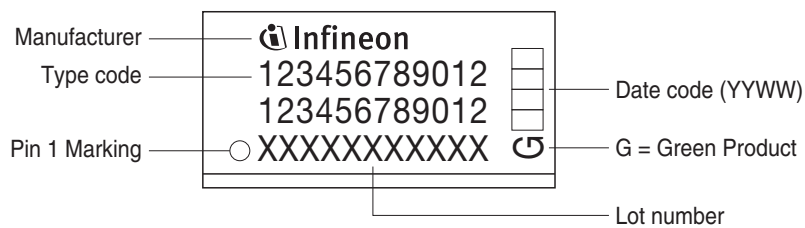

Tape and Reel

Reel ø330 mm: 1.000 Pieces/Reel
Reels/Box: 1

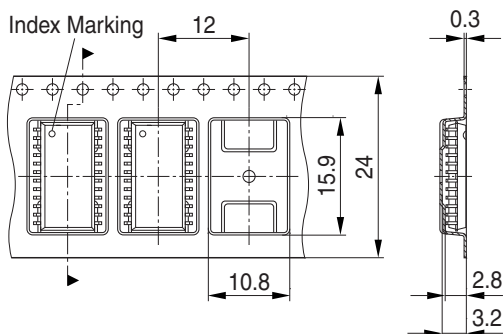

Tube

Length: 528
Piece/Tube: 30
Tubes/Box: 40

