

An aerial night view of a city skyline, likely Dubai, showing numerous illuminated skyscrapers and a dense urban landscape. The lights from the buildings and streets create a vibrant, golden glow against the dark blue night sky. The city extends to the coast, with the sea visible in the distance.

Innovative Semiconductor Solutions

for Energy Efficiency, Mobility and Security

Application Overview

Introduction	3
Automotive	4
Small Electric and Combustion Engines	5
Commercial, Construction and Agricultural Vehicles (CAV)	6
Motor Control and Drives	8
Security for IoT	11
Industrial Automation	12
Energy Generation (Solar and Wind)	14
Energy Transmission and Consumption (Smart Grid)	16
Power Supplies	18
Home Appliances	19
Lighting	20

Society currently faces a number of challenges. The world's population is growing rapidly, more and more megacities are forming and demand for energy continues to spiral across the globe. In addition, the rising need for climate protection calls for new levels of energy efficiency and more sustainable lifestyle choices.

At the same time, we are seeing the growing networking and cloud-enablement of all sorts of physical devices from wearables and cars to home appliances and factories. This increasingly connected world presents new demands for data security.

As a leading semiconductor player, we develop solutions that address today's energy efficiency, mobility and security challenges. Our innovative solutions optimize the generation, transmission and consumption of power, for instance, also maximizing energy efficiency in everything from computers to industrial drives. In addition, we are enabling the development of cars and vehicles offering greater energy efficiency, functionality and safety. And our robust security solutions create an anchor of trust in today's computing devices, protecting the integrity, authenticity and confidentiality of information as it travels across the Internet of Things.

Visit our application solutions site for comprehensive system block diagrams, products and resources to complete your design.



www.infineon.com/motorcontrol

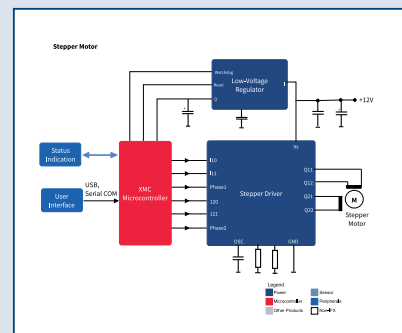



Automotive

Driving the future of automotive electronics

At Infineon, we are already powering the mobility choices of tomorrow. Our sensors, microcontrollers and power semiconductors help automotive manufacturers achieve their increasingly challenging safety, efficiency and convenience targets.

Our power semiconductors are contributing to more efficient drivetrains. In particular, they play an enabling role in the fast-growing number of electric and hybrid vehicles on the road by supporting power conversion, management and distribution. Infineon is actively helping to reduce the carbon footprint of today's mobility.

As system complexity increases in cars, so too does the volume of data to be processed and distributed. Automakers therefore need to ensure that information is processed securely and protected against external access and manipulation (e.g. car tuning or counterfeit spare parts). Infineon can draw on years of expertise in chip card and identification systems to propel automotive data security to the next level.

Infineon is continuously optimizing the chipsets that enable the safety features designed to reduce the number of road accidents. Having the most rigorous EuroNCAP in mind, we lead the field in many safety innovations for passive, active and preventive safety systems like RADAR technologies. Regarding the ISO Standard 26262 we adopted our design of appropriate products, but also to set up the appropriate processes for developing such products.





Small Electric and Combustion Engines

Small but powerful

Rising standards of living, the growing need to conserve limited natural resources and increasingly strict emissions legislation are driving a shift from mechanical to electronic control systems in small conventional vehicles such as motorcycles. This trend is evident worldwide, especially in emerging markets. At the same time, demand for small electric vehicles (SEV) such as electric-powered bicycles (e-bikes and pedelecs) is also rising around the globe.

At Infineon, we are bringing new, electrified mobility choices to life and enhancing the energy efficiency of conventional combustion engines. We deliver a wide range of efficiency-enabling semiconductor solutions in the small 1- to 2-cylinder combustion engine segment, all designed to help manufacturers comply with stricter carbon emission regulations.

As the market leader in automotive electronics, we are ideally positioned to meet growing needs for fuel-efficient solutions through a wide range of microcontrollers, sensors, power supplies, transceivers, driver ICs, MOSFETs, IGBTs as well as fully integrated chip solutions. Delivering advanced real-time performance, our 16-bit and 32-bit microcontroller portfolios already create headroom for emerging trends such as sensor-less control and new functional safety features.





Commercial, Construction and Agricultural Vehicles (CAV)

High resilience for low-power CAVs

Manufacturers of commercial, construction and agricultural vehicles (CAV) are looking for cost-effective ways to increase robustness, service life and temperature range.

We offer a vast automotive-qualified portfolio of protected high-side and low-side switches with integrated protection and diagnostic features to drive actuators in 24-volt applications. These switches can drive all kinds of loads (resistive, capacitive and inductive) in lighting, power distribution, relays and motor drives. They are also ideal replacements for relays.

In addition, we combine various innovative technologies such as MOSFETs, S-Smart power and logic and Smart Power Technologies (SPT) with advanced assembly techniques to create forward-looking products for the next generation of innovative 24V solutions. Complementing our broad 24V portfolio, we also offer the building blocks for end-to-end 24V solutions, including voltage regulators, communication ICs, microcontrollers and sensors.





Setting the standards for high-power CAVs

Rising demand for fuel and operational efficiency is driving electrification in the high-power CAV segment. The replacement of hydraulic with electric drives gives manufacturers the benefit of greater energy efficiency, compliance with increasingly strict legislation and higher productivity. In the near future, more and more tasks in industry, transport and transit will be powered by fully electric or at least partially electric (hybrid) drives.

We are ready to support designers and developers with the semiconductor components needed to enable the transition to greater fuel economy, productivity and reliability. For example all of our high-power modules are designed to meet the most stringent lifetime and reliability standards. Advanced bond wire and base-plate technologies support extreme vibration loads and temperature cycling conditions. In addition, our CAV modules are manufactured to the highest quality on automated production lines and allow 150°C operating junction temperature. Highlights include our PrimePACK™ and HybridPACK™ families.





Motor Control and Drives

Top power ratings for battery-powered, home & building applications

Battery life is the number one criteria for battery-powered motor control applications such as light electric vehicles (pedelecs and e-bikes) and cordless power tools. We have developed a range of devices to deliver the highest possible energy efficiency and top precision in power management, power consumption and voltage regulation. Highlights include our high-voltage power MOSFETs (CoolMOS™), XMC microcontrollers, EiceDRIVER™ gate drivers and n-channel low-voltage power MOSFETs (OptiMOS™).

Motor control applications are also widely used in homes and buildings. Here, applications such as fans and pumps are typically connected to the power supply. Many power tools are also designed for grid connection. With these motor control applications, efficiency is the key success factor.

We have designed a range of dedicated solutions for maximum efficiency and power ratings, including a variety of dedicated AC/DC power management ICs and active PFC devices. Designers will find the precise feature set they need in our wide portfolio, along with innovative solutions to connect motor control applications to building automation networks.





Driving efficiency into industrial motor control applications

Today's industrial motor control systems are expected to set new standards for energy efficiency, dynamic behavior, robustness and service life. Typical industrial automation applications include food processing, packaging, logistics systems, tool machines and robotics. Industrial AC and servo drives are often the key to increasing dynamic performance, precision and reliability.

We have developed a full range of motor control solutions to boost the performance of industrial applications – from microcontrollers and gate drivers through MOSFETs, IGBTs, voltage regulators and sensors to integrated bridge driver ICs, integrated power modules and high-power modules. Highlights include our CoolMOS™ MOSFETs, EiceDRIVER™ gate drivers and XMC microcontrollers. Our XMC microcontroller family with an ARM® Cortex™-M0 or Cortex™-M4 core, for instance, is engineered to sit at the heart of a top-caliber motor control system. In real-time, it can quickly compute cascaded control tasks, while measuring current, position and speed with ultimate precision.





Wireless



Boards & Systems

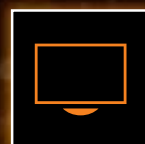

Displays



Storage

Combine Technologies

Realize **EMBEDDED** Designs

RUTRONIK **EMBEDDED** brings together entire solutions to build applications for:

- Digital Signage
- Medical
- Industrial Control
- Transportation

Learn more: www.rutronik.com/embedded

Get in touch:
embedded@rutronik.com or call +49 (0) 7231 801-1776



The Right Security for IoT

The Internet of Things (IoT) is moving from a centralized structure to a complex network of decentralized smart devices. This increasingly connected world will see the growing networking and cloud-enablement of all sorts of physical devices from wearables through cars to home appliances. It is even transforming manufacturing as we move towards smart, interconnected factories powered and secured by smart semiconductor solutions. This networked world presents new demands in terms of energy efficiency, connectivity and – above all – security.

For almost 30 years, Infineon has been providing security solutions to protect users' data and has already shipped nearly 20 billion security controllers worldwide. Now, we are bringing our market and innovation leadership to the IoT realm, offering the right security for IoT. Our power management devices, sensors and microprocessors are powering and securing a broad set of smart applications over the IoT. Even more importantly, our security controllers create an anchor of trust, supporting device integrity checks, authentication, secured communication and key management. Our portfolio ranges from basic authentication products (OPTIGA™ Trust) to advanced implementations (OPTIGA™ TPM) protecting integrity, authenticity and confidentiality of information for secured communications across the IoT.





Industrial Automation

The industrial automation advantage

The growing pace of industrial automation and networking across industrial control systems presents manufacturers with new and bigger challenges. They need industrial-grade components that can withstand harsh manufacturing environments, meet the latest energy efficiency standards and offer robust levels of security, especially as communication over the Internet of Things increases.

An industrial PC, for instance, must be fit for purpose. In other words, it must have a robust architecture that can weather rugged environments; a stable high-performance design that won't crash; and a long innovation cycle for an extended service life. In addition, it must be secure against manipulation and cyber attacks.

This same applies to all other industrial control and automation applications – Human Machine Interfaces (HMI), Programmable Logic Controllers (PLC), micro PLCs, industrial power supplies, industrial sensors, motor controls and drives, industrial communication devices and line actuators. Although these applications stretch over three solution layers – the supervisor, control and field levels – the same standards of performance, ruggedness and security apply at each layer.





Powering today's smart factories

Already today, 90 percent of manufacturing processes are supported by information and communication technologies (ICT). This interconnection trend is gathering pace, referred to as the “Fourth Industrial Revolution” (“Industry 4.0” or “Industrial Internet”). Accelerated by initiatives such as the German government’s project of the same name (“Industry 4.0”), this stage of industrial development and production promises huge resource efficiency gains, individualized products and greater adaptability. This is all being made possible through the intelligent sharing of information across the entire production and logistics chain and through rich and varied interaction between smart products, intelligent resources and production facilities. Therefore, Industry 4.0 means more than just a smart factory: It enables the stronger integration of customers and business partners.

The success of Industry 4.0 hinges on powerful, secure and smart semiconductor solutions such as our microcontrollers, power devices and sensors. They are enabling the growing penetration of embedded systems, which blur the boundaries between physical devices and cyberspace in favor of cyber-physical systems. Featuring our advanced security technologies, these cyber-physical systems will support even greater communication and alignment between machines, robots, resources, storage systems and services over the Internet of Things.





Energy Generation

Cost, efficiency and reliability gains for solar

Climate concerns are driving the popularity of solar power. The viability and success of this fast-expanding market hinges, however, on the ability of system manufacturers to squeeze system costs, increase system efficiency and extend reliability. Inverter manufacturers are challenged to systematically optimize the price-per-watt of solar power at system level, for instance. In addition, investors are looking for higher system efficiency and reliability levels to ensure maximum return on their outlay. The answer to these challenges often lies in innovative semiconductor solutions.

Market leader in solar applications, we offer a comprehensive portfolio designed for the best efficiency and reliability levels. For example, our next-generation CoolMOS™ C7 and TRENCHSTOP™ 5 IGBT technologies minimize switching losses, enabling higher switching frequencies. This paves the way for cost reductions on magnetic, housing and cooling parts. Designers can also rely on our CoolMOS™ P6 and TRENCHSTOP™ 5 devices for a superior price/performance ratio. On the efficiency front, CoolMOS™ C7 offers industry-leading efficiency levels in hard-switching topologies, whereas CoolMOS™ CFD2 and CoolMOS™ P6 optimize efficiency across all load levels in soft-switching architectures. Our new OptiMOS™ family also sets new efficiency benchmarks, as does our latest ARM® Cortex™-M4 based microcontroller. Last but not least, we are helping inverter manufacturers to raise the bar for reliability, building on our long-standing experience in Si and SiC devices and power module to constantly optimize robustness. Other highlights include our EiceDRIVER™ driver ICs and boards with coreless transformer technology, and our PressFIT mounting technology for highest performance and contact reliability.



www.infineon.com/solar



Fresh blast for wind energy

Similar to solar power, wind energy is growing in popularity. Typically installed in extremely harsh surroundings and exposed to huge stresses, wind turbines must be designed to deliver maximum levels of availability in order to contribute to grid stability.

In wind turbines, power semiconductors are used to convert power and couple the generator with the grid. They are also built into various auxiliary drives such as yaw drives, pitch drives, pumps and into protection circuits like crowbars. Power semiconductors play a key role in ensuring reliable operation of converters and drives. Grid stability thus depends on converter and drive assemblies offering dynamic capabilities coupled with outstanding functionality and superior reliability.

We deliver the full range of grid coupling components, with thyristors and other bipolar semiconductors available as modules, discs and stacks. Engineered for modular and scalable designs, our IGBTs support optimum performance even at the limits of the operating range for maximum system availability. We also deliver robust protection circuits for crowbars, choppers and active filters, along with small inverters for optimum control of yaw drives, pitch drives and pumps.





Energy Transmission and Consumption

Packing more intelligence into smart grids

Climate change, rising energy consumption in emerging economies and growing demand for energy efficiency in industry is accentuating the need for a low-carbon economy. One of the key building blocks in a low-carbon energy chain is a smart grid. Smart grids promise greater sustainability through the integration of renewable sources of energy, reduced carbon emissions, greater security of supply and the capacity to balance supply and demand. All of this can only be achieved with the help of smart semiconductors. Intelligent devices, sensors and microcontrollers are needed, for instance, to allow distributed control. Efficient power semiconductors can also reduce power losses and increase reliability, and security technologies are essential to prevent fraud and malicious attacks.

Across the full energy chain from conversion and transmission to smart consumption, we have developed a vast portfolio of semiconductor devices to power the transition to smart grids, cities and homes. With a strong focus on energy efficiency and security, our reliable, cost-effective ICs and power devices are easy to deploy. And we are constantly evolving our portfolio to ensure we can supply our customers with the best new smart grid technologies and components as we move closer to the vision of a low-carbon economy.



www.infineon.com/smartgrid

POWER BOOSTER

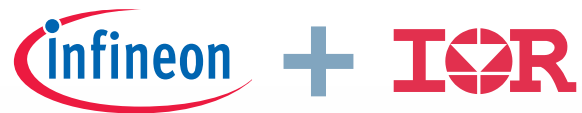

The acquisition of International Rectifier by Infineon delivers a powerful combination: From the latest 600 V GaN-on-Si and 1200 V SiC products to efficient MOSFETs, IGBTs, drivers, and space-saving power modules, Infineon is now the premier source for power products.

Looking for a competent partner to explore the combined Infineon + IR Power portfolio? Benefit from SILICA's strong partnership with both Infineon and IR and the outstanding technical support from SILICA's Power Experts.

For more information please visit:
www.silica.com/infineon



Power 'n More
SILICA Power Design Support

 **SILICA**[™]
An Avnet Company



Power Supplies

Meeting power supply pressures head on

Power supply manufacturers are challenged to comply with tighter specifications, accelerate cycle times, reduce costs and, in the case of high-power applications, differentiate their offering more effectively. The answer lies in state-of-the-art power supplies built to the highest efficiency, power density and reliability standards.

We have developed a broad portfolio of high-end products for Switched Mode Power Supply (SMPS) applications such as server, telecom, uninterruptible power supply (UPS), PC, TV, notebook charger and adapter power supplies. Not only do we offer the best products for individual design challenges, we back these up with demo boards and reference designs for faster time-to-market. Highlights include our CoolMOS™ high-voltage MOSFETs, OptiMOS™ low-voltage MOSFETs, thinQ!™ SiC Schottky barrier diodes, EiceDRIVER™ driver ICs, Rapid 1 and Rapid 2 silicon power diodes, XMC microcontrollers as well as CoolSET™ and ICE analog controller ICs.



www.infineon.com/smps



Home Appliances

Curbing the appetite of power-hungry household appliances

Household appliances can be a significant energy drain. Today's consumers want smart, efficient household equipment that delivers environmentally responsible performance while helping to cut utility costs. This means that product designers need to deliver smaller, smarter, more powerful and more energy-efficient appliances.

We deliver state-of-the-art solutions to help designers meet this challenge. Based on industry-leading technologies and our long-standing manufacturing expertise, our line of innovative components for household appliances meets and exceeds even the most rigorous requirements for reliability and quality.

Our EiceDRIVER™ family with Coreless Transformer (CLT) and Level-Shift (LS-SOI) technology, for instance, is the ideal high-performance gate driver IC for major home appliances. Combined with MOSFETs like CoolMOS™, IGBTs and Silicon Carbide (SiC) power devices in discretes and modules, EiceDRIVER™ ICs allow designers to engineer and build reliable and efficient systems for today's discerning consumers.





Lighting

Spotlight on smart lighting with LEDs

The lighting industry is rapidly evolving towards more energy-efficient lighting solutions. This generally means transitioning from traditional lighting sources to efficient lighting with LEDs. They offer huge energy savings, reducing consumption even further when dimmed. In addition, they can be easily connected to the second major building block in energy-efficient lighting installations – intelligent lighting control systems. Known as smart lighting, these management solutions promise even greater energy savings, adjustable light levels and selectable ambient color. Smart lighting also supports automation.

Our innovative AC/DC and DC/DC solutions are built around best-in-class LED driver ICs. We also offer a full portfolio of high-voltage (CoolMOS™) and low-voltage (OptiMOS™) MOSFETs. In addition, our DC/DC or linear LED topologies can be used to drive multiple strings of LEDs in residential, commercial and outdoor applications.

Complementing our LED driver portfolio, we deliver a broad range of microcontrollers and sensors to support light management systems by enabling:

- Connectivity to bus systems such as DALI, DMX, KNX, etc.
- Connectivity to sensors
- Programming of intelligent light features tailored to individual requirements

Highlights include our new ARM®-based XMC1000 microcontroller family with optimized peripherals for LED lighting and our 24 GHz radar demonstrator kit for advanced presence detection with a light output adjustment function for additional energy savings.



Efficiency in general and automotive lighting

Looking beyond LEDs and smart lighting systems, we deliver efficient lighting solutions across the full spectrum from general lighting through fluorescent and HID lamps to automotive lighting. All of our semiconductors are engineered to improve system efficiency, with high-voltage MOSFETs (CoolMOST™) for instance offering best-in-class thermal resistance performance. Our fluorescent controller ICs offer the lowest-possible system cost thanks to a high level of integration, excellent system performance and very low total harmonic distortion (THD). They are ideal for numerous general lighting applications.

We also have a broad lighting portfolio optimized for interior and exterior automotive lighting applications, including protected single- and multi-channel power switches. Highlights include our PROFET™ families with smart diagnostic and protective features. Our SPOC™ products deliver control, configuration and diagnostic capabilities through the Serial Peripheral Interface (SPI).

Last but not least, with our Automotive LITIX™ LED driver families, we support the fast-growing automotive trend to replace bulbs with LEDs across all lighting applications.

Announcing Infineon's Newsletter4Engineers

The news you need, every month

Infineon is excited to announce the Newsletter4Engineers - coming to you every month with news tailored to your interests.

Newsletter4Engineers builds on the 15-year success of the quarterly Design:)Link, retired after the October 2014 issue. Infineon is pleased to provide Newsletter4Engineers as a reliable tool to help engineers around the world get ahead of trends.

What's new in Newsletter4Engineers?

- News gets to you faster, at the beginning of each month.
- You get all the news you need in one newsletter: new products, applications and tools; industry events; webinars and tutorials.
- You choose your news! Choose the news specific to your region, industry, application and product demand.

Register for Newsletter4Engineers and join the Infineon4Engineers community to connect with engineers all over the world and receive Infineon news and updates regularly.

Register here: <http://infineon-community.com/newsletter>

Ask Infineon. Get connected with the answers.

Infineon offers its toll-free 0800/4001 service hotline as one central number, available 24/7 in English, Mandarin and German.

Our global connection service goes way beyond standard switchboard services by offering qualified support on the phone. Call us!

- Germany 0800 951 951 951 (German/English)
- China, mainland 4001 200 951 (Mandarin/English)
- India 000 800 4402 951 (English)
- USA 1-866 951 9519 (English/German)
- Other countries 00* 800 951 951 951 (English/German)
- Direct access +49 89 234-0 (interconnection fee, German/English)

* Please note: Some countries may require you to dial a code other than "00" to access this international number, please visit www.infineon.com/service for your country!

Where to Buy

Infineon Distribution Partners and Sales Offices:
www.infineon.com/WhereToBuy

Stay Connected

-  www.facebook.com/infineon
-  www.google.com/+infineon
-  www.twitter.com/infineon
-  www.infineon.com/linkedin
-  www.infineon.com/xing
-  www.youtube.com/infineon

Mobile Product Catalog

Mobile app for iOS and Android:
www.infineon.com/apps



Published by
Infineon Technologies AG
85579 Neuburg, Germany

© 2015 Infineon Technologies AG.
All Rights Reserved.

Visit us:
www.infineon.com

Order Number: B179-I0086-V1-7600-EU-EC-P
Date: 02/2015

Please note!

THIS DOCUMENT IS FOR INFORMATION PURPOSES ONLY AND ANY INFORMATION GIVEN HEREIN SHALL IN NO EVENT BE REGARDED AS A WARRANTY, GUARANTEE OR DESCRIPTION OF ANY FUNCTIONALITY, CONDITIONS AND/OR QUALITY OF OUR PRODUCTS OR ANY SUITABILITY FOR A PARTICULAR PURPOSE. WITH REGARD TO THE TECHNICAL SPECIFICATIONS OF OUR PRODUCTS, WE KINDLY ASK YOU TO REFER TO THE RELEVANT PRODUCT DATA SHEETS PROVIDED BY US. OUR CUSTOMERS AND THEIR TECHNICAL DEPARTMENTS ARE REQUIRED TO EVALUATE THE SUITABILITY OF OUR PRODUCTS FOR THE INTENDED APPLICATION.

WE RESERVE THE RIGHT TO CHANGE THIS DOCUMENT AND/OR THE INFORMATION GIVEN HEREIN AT ANY TIME.

Additional information

For further information on technologies, our products, the application of our products, delivery terms and conditions and/or prices please contact your nearest Infineon Technologies office (www.infineon.com).

Warnings

Due to technical requirements, our products may contain dangerous substances. For information on the types in question please contact your nearest Infineon Technologies office.

Except as otherwise explicitly approved by us in a written document signed by authorized representatives of Infineon Technologies, our products may not be used in any life endangering applications, including but not limited to medical, nuclear, military, life critical or any other applications where a failure of the product or any consequences of the use thereof can result in personal injury.

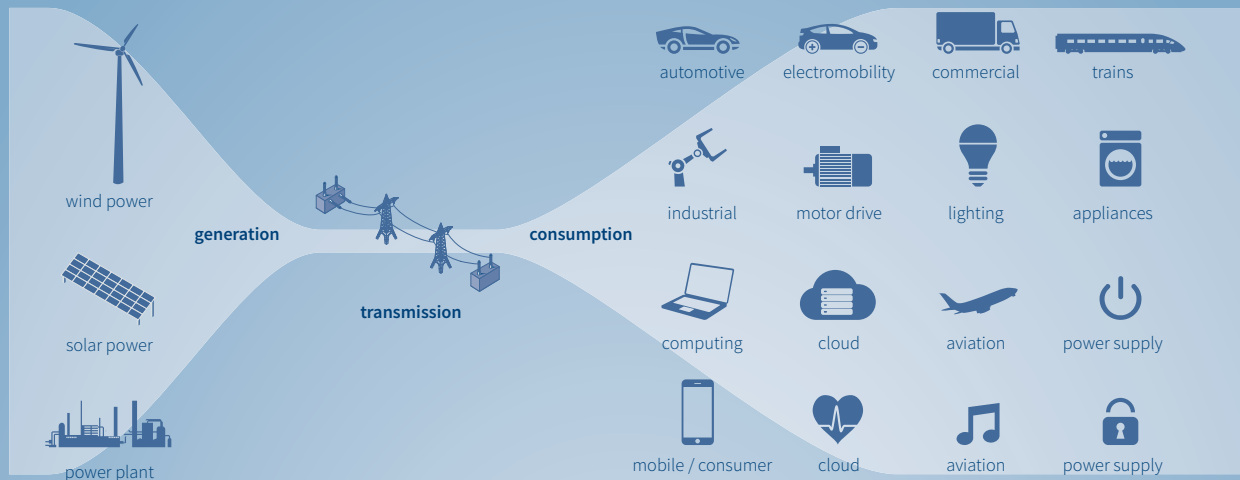

infineon + IOR = A Powerful Combination

Infineon and International Rectifier make a powerful combination and a unique opportunity for you. From the latest 600V GaN-on-Si and 1200V SiC products to efficient MOSFETs, IGBTs, drivers, and space-saving power modules, we're now your 1-stop high-voltage and low-voltage power source. We also offer leading-edge microcontrollers, sensors, and RF products, too. Together, Infineon and International Rectifier deliver more.

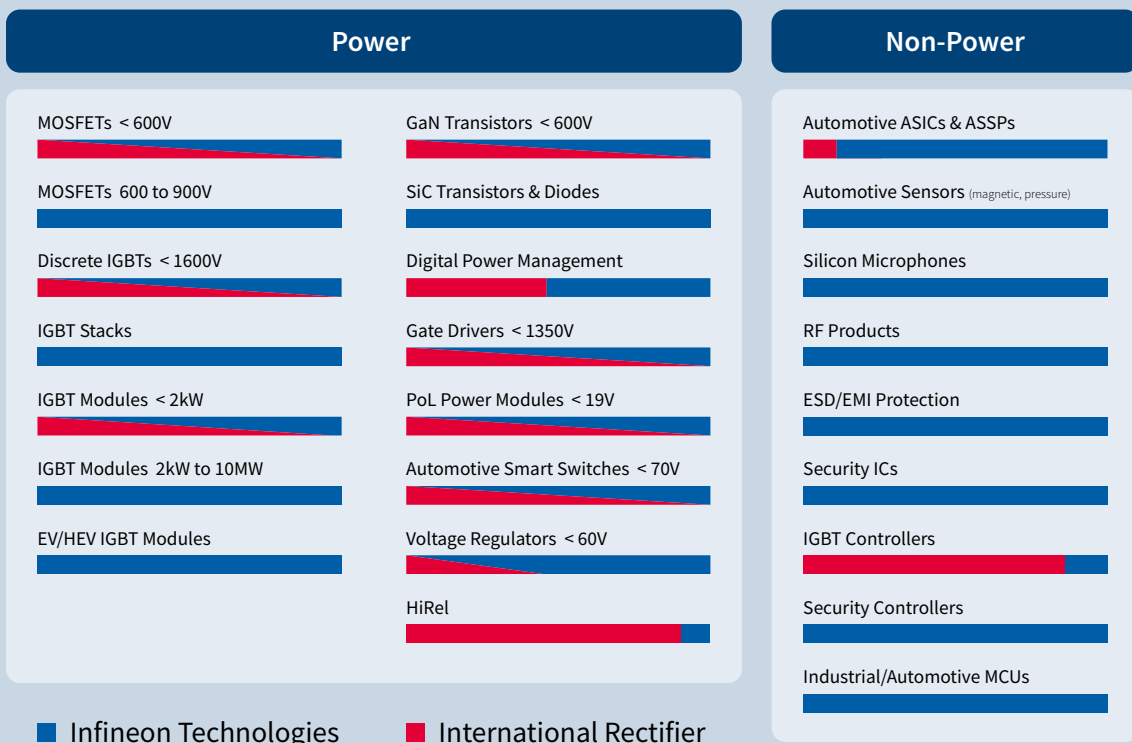

Explore our combined portfolio for your application: www.infineon.com/applications