

EconoPACK™ +  
FIT FOR THE FUTURE



EconoPACK™ + the Standard Today

**The Original since 2000!**

**FIT FOR THE FUTURE**



**Make the Next Step forward with  
the new  
EconoPACK™ + D-Series**



# Key Applications



- Renewable Energies  
Wind & Solar
- Commercial Vehicles & Tramway
- Auxillary Traction Inverter
- Elevator
- Industrial Drives
- Power Supplies



# EconoPACK™ + D-Series – Robust & Reliable

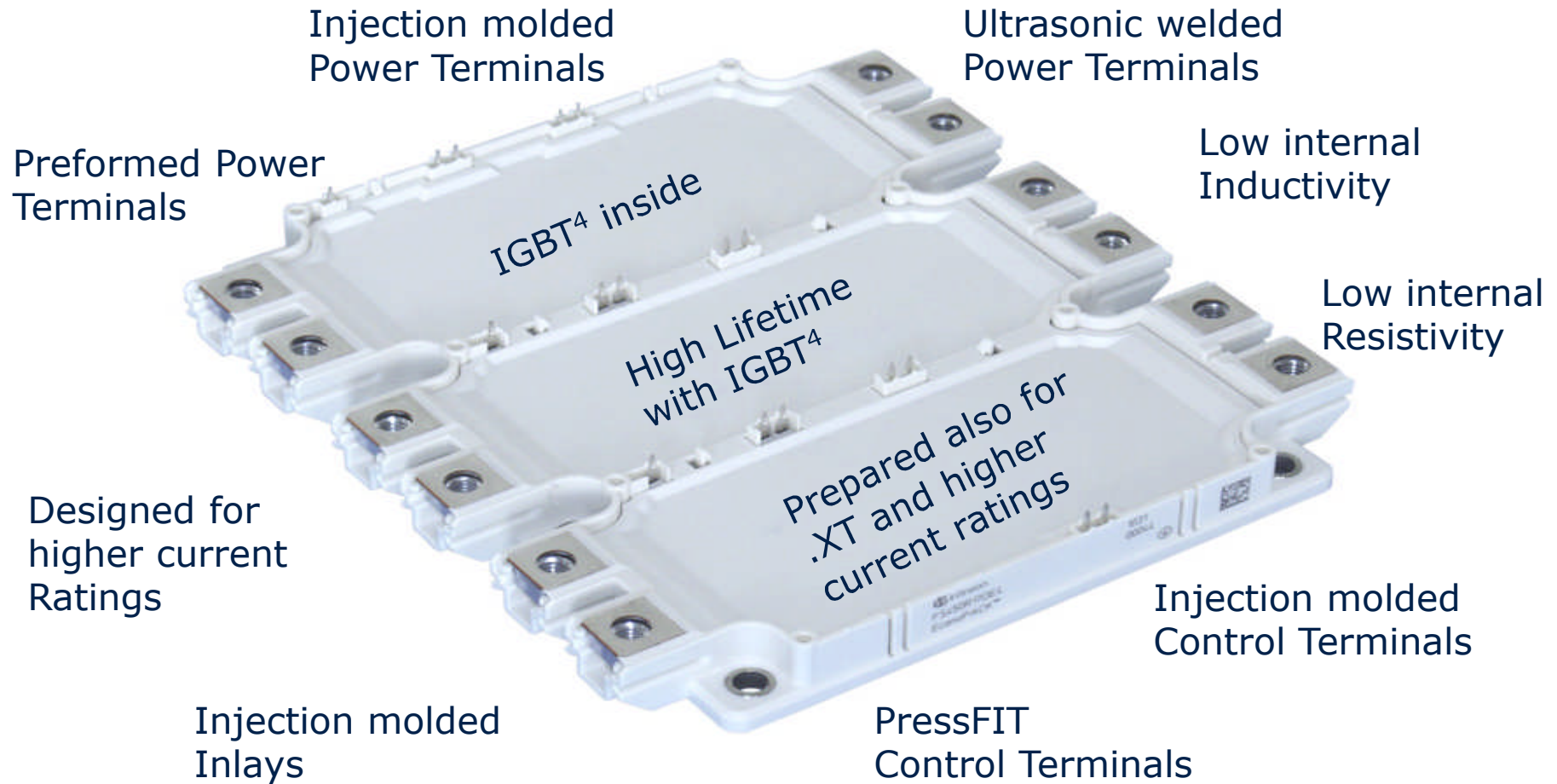

## Ultrasonic welded Terminals

- All internal Power Terminals are **ultrasonic welded**
  - Increased mechanical Robustness
  - Higher Terminal Currents possible
  - Maximum Temperature even reduced

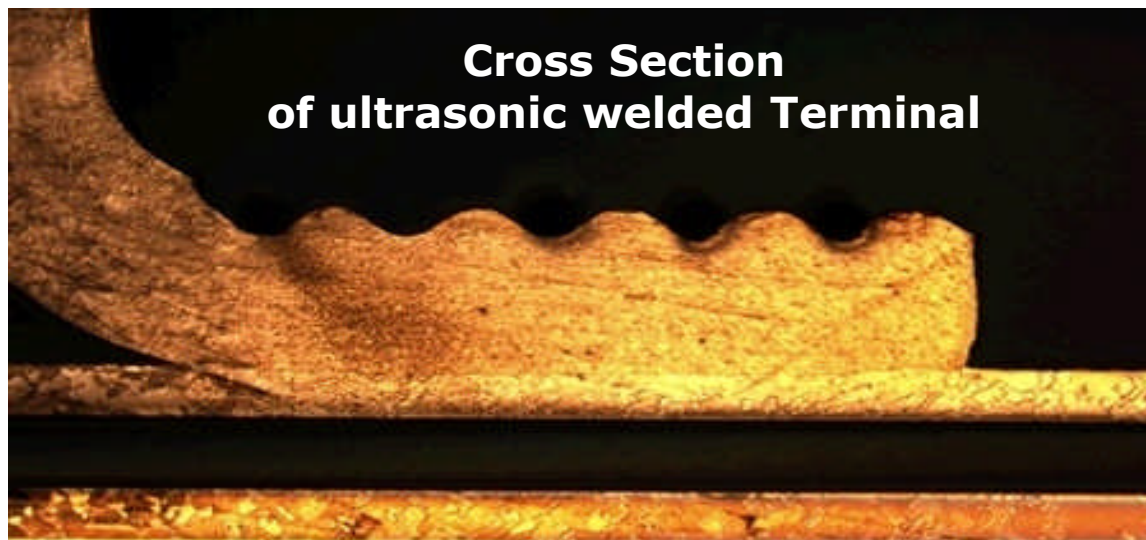
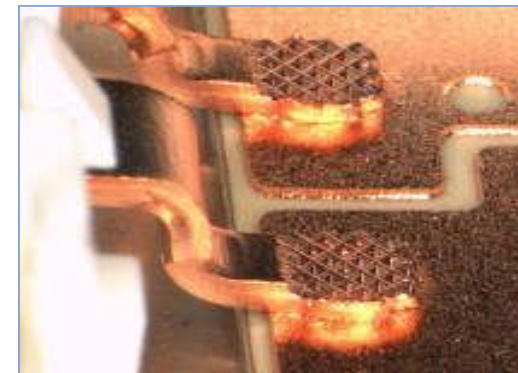

**Cross Section  
of ultrasonic welded Terminal**

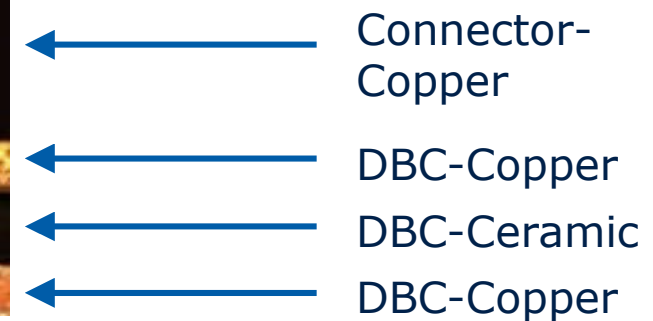



# EconoPACK™ + D-Series solder less Control Pins

**EconoPACK™ +  
D-Series**

**+ Press**

**=**

**FIT**

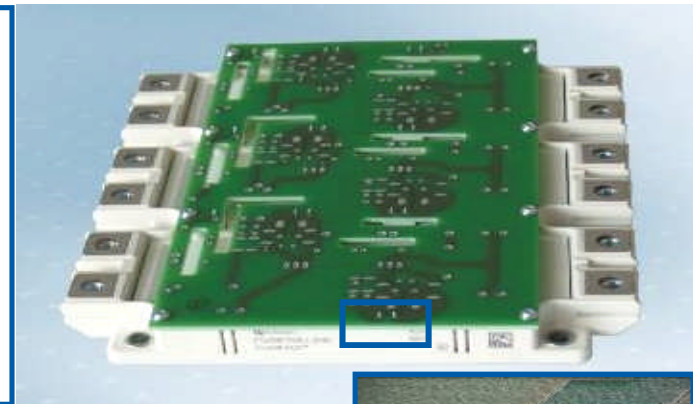
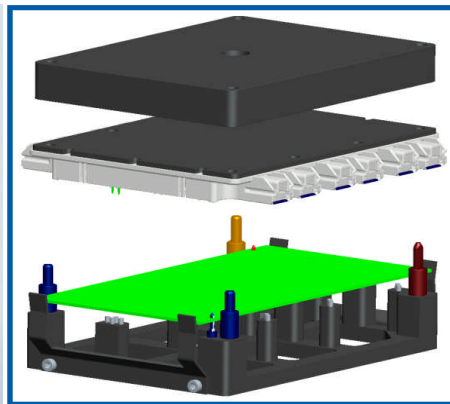

## PressFIT Technology

- **Lead free** mounting to meet RoHS
- **Approved Technology, already used in Automotive**
- **Easy Solder less mounting** Concept saves Production Cost and Time
- **High Reliability** by decreasing FIT Rate compared to Spring or Solder Contacts

# EconoPACK™ + D-Series 1700V IGBT4-E4

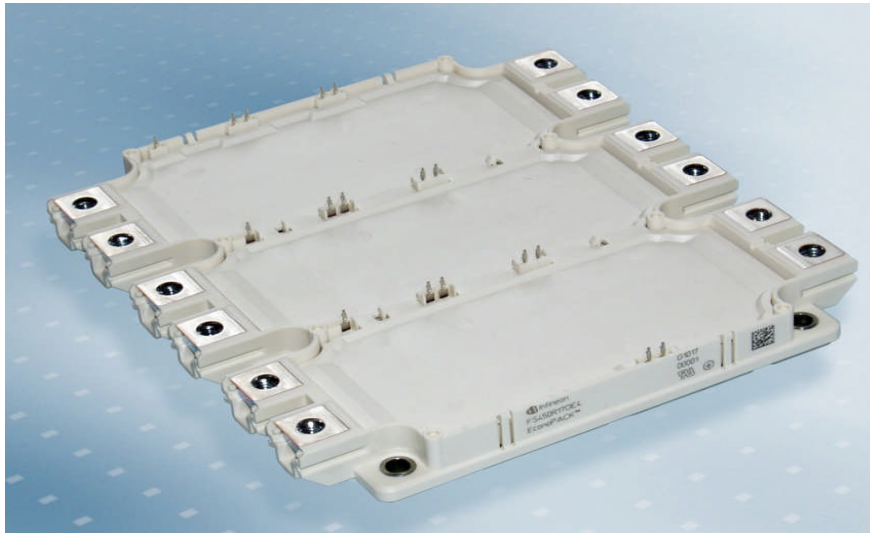

## SixPACK with NTC

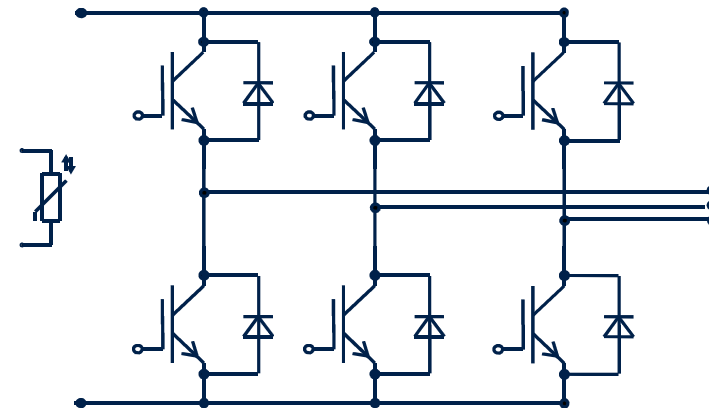

### SixPACK Modules with 1700V IGBT4-E4

Nominal current / Peak current per Switch

FS225R17OE4 :  $I_{Cnom} = 225A$  /  $I_{CRM} = 450A$

FS300R17OE4 :  $I_{Cnom} = 300A$  /  $I_{CRM} = 600A$

**FS450R17OE4 :  $I_{Cnom} = 450A$  /  $I_{CRM} = 900A$**

$T_{vjop} = 150^{\circ}C$

$T_{vjop} = 150^{\circ}C$

**$T_{vjop} = 150^{\circ}C$**

Higher current Ratings are under Development

# EconoPACK™ + D-Series 1200V IGBT4-E4

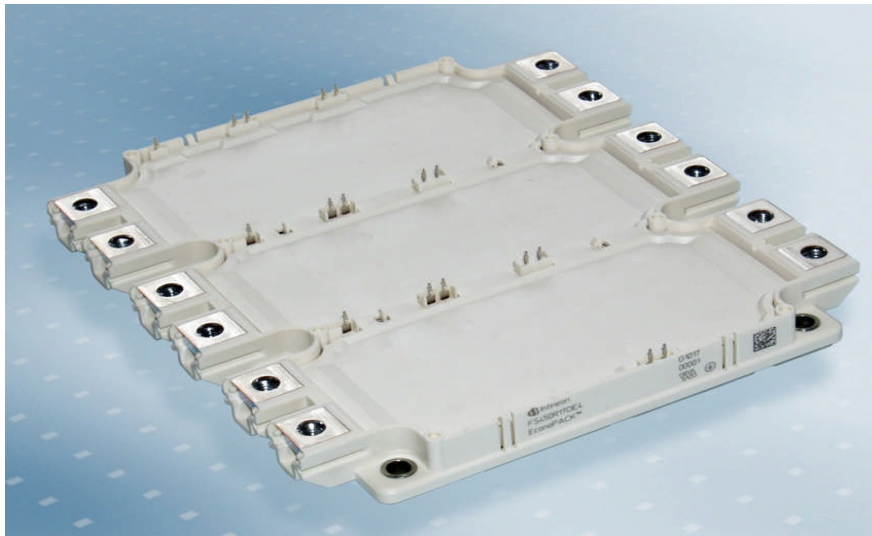

## SixPACK with NTC

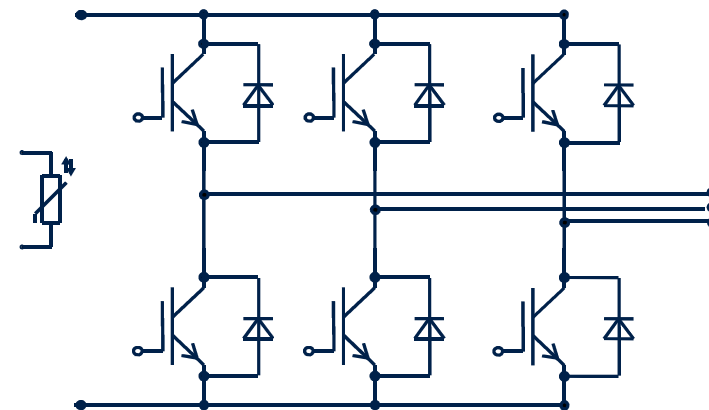

### SixPACK Modules with 1200V IGBT4-E4

Nominal current / Peak current per Switch

FS225R12OE4 :  $I_{Cnom} = 225A$  /  $I_{CRM} = 450A$       $T_{vjop} = 150^{\circ}C$

FS300R12OE4 :  $I_{Cnom} = 300A$  /  $I_{CRM} = 600A$       $T_{vjop} = 150^{\circ}C$

FS450R12OE4 :  $I_{Cnom} = 450A$  /  $I_{CRM} = 900A$       $T_{vjop} = 150^{\circ}C$

FS ... Higher current Ratings are also under Development



# EconoPACK™ + D-Series – FIT FOR THE FUTURE



EconoPACK™ + D-Series the next Evolution Step in Reliability and Power Density for advanced Inverter Designs

**Make the Next Step forward with the new EconoPACK™ + D-Series**

## ■ Focused on robust and reliably Design

- PressFIT Control Pins
- Injection molded Terminals
- State of the Art IGBT Technology
- Ultrasonic welded Power Terminals

## ■ Same Assembly and mounting Processes

as applied for the B-Series can be used

## ■ High current Density for compact Inverter Designs

- Optimized internal Layout

## ■ Prepared for higher current ratings utilized .XT and IGBT5







# ENERGY EFFICIENCY MOBILITY SECURITY

Innovative semiconductor solutions for energy efficiency, mobility and security.

