A large, light blue decorative graphic consisting of a thick, curved line that forms a partial circle, with a smaller circle at its top end, resembling a stylized 'C' or a partial orbit.

Driving Mid & High Power LEDs  
From 65mA to 700mA with  
Thermal Protection LED Controller IC  
**BCR450**

## Application Note 105

<http://www.infineon.com/lowcostleddriver>

Rev. 1.1, 2007 -11 -19

**Edition 2007-11-19**

**Published by  
Infineon Technologies AG  
81726 München, Germany**

**© Infineon Technologies AG 2009.  
All Rights Reserved.**

## **LEGAL DISCLAIMER**

THE INFORMATION GIVEN IN THIS APPLICATION NOTE IS GIVEN AS A HINT FOR THE IMPLEMENTATION OF THE INFINEON TECHNOLOGIES COMPONENT ONLY AND SHALL NOT BE REGARDED AS ANY DESCRIPTION OR WARRANTY OF A CERTAIN FUNCTIONALITY, CONDITION OR QUALITY OF THE INFINEON TECHNOLOGIES COMPONENT. THE RECIPIENT OF THIS APPLICATION NOTE MUST VERIFY ANY FUNCTION DESCRIBED HEREIN IN THE REAL APPLICATION. INFINEON TECHNOLOGIES HEREBY DISCLAIMS ANY AND ALL WARRANTIES AND LIABILITIES OF ANY KIND (INCLUDING WITHOUT LIMITATION WARRANTIES OF NON-INFRINGEMENT OF INTELLECTUAL PROPERTY RIGHTS OF ANY THIRD PARTY) WITH RESPECT TO ANY AND ALL INFORMATION GIVEN IN THIS APPLICATION NOTE.

## **Information**

For further information on technology, delivery terms and conditions and prices please contact your nearest Infineon Technologies Office ( [www.infineon.com](http://www.infineon.com) ).

## **Warnings**

Due to technical requirements components may contain dangerous substances. For information on the types in question please contact your nearest Infineon Technologies Office.

Infineon Technologies Components may only be used in life-support devices or systems with the express written approval of Infineon Technologies, if a failure of such components can reasonably be expected to cause the failure of that life-support device or system, or to affect the safety or effectiveness of that device or system. Life support devices or systems are intended to be implanted in the human body, or to support and/or maintain and sustain and/or protect human life. If they fail, it is reasonable to assume that the health of the user or other persons may be endangered.



---

Application Note No. 105

Revision History: 2007-11-19, Rev. 1.0

Previous Version:

Page	Subjects (major changes since last revision)

## 1 Description

The BCR450, realized in a bipolar power technology, is a low cost linear regulator LED controller IC for industrial applications designed to operate as a constant current source. The LED controller is capable of driving high current, high brightness LEDs up to 2.5 A by using additional external output stages as “booster” transistors.

This device operates over a 8 V - 27 V input voltage range and high output accuracy is maintained over a broad current range, from 0 to 85 mA.

For LED currents up to 85 mA the IC can be used as a stand alone device and requires only one external low side current sense resistor which monitors the output current to guarantee accurate current regulation.

The voltage drop across the sense resistor is only in the range of 0.12 V - 0.15 V, which contributes to a very small supply voltage overhead of typically 0.5 V. This low voltage drop minimizes wasted DC power and maximizes the number of LEDs that can be used in a series 'stack'.

The IC can be switched on and off by applying an external signal to the EN (Enable) pin of the device, which also linearly varies the LED brightness up to the programmed LED current by PWM (Pulse Width Modulation) dimming.

The precise internal bandgap stabilizes the circuit and provides constant current over the full temperature range. In addition, the current supply uses a sense control function with feedback mechanism that regulates the LED current.

Finally, an over voltage/current protection and temperature shut down mechanism is provided, which protects the LEDs and an Output Short Circuit protection block avoids to damage the IC in the event of a short-circuit at the output pin of the BCR450.

The BCR450 typically draws only 1.5 mA when operating in the no-load condition and draws typically less than 50 nA when the device is shut down.

In “boost” mode, where an external transistor is used for LED currents over 85 mA, the BCR450 is designed to work with a PWM frequency up to 1KHz in addition with a typical PWM range from 1% to 100%. The IC provides a wide dimming range of 1100:1 at a PWM frequency of 1 kHz.

The BCR450 is supplied in a small 6-pin TSOP6 / SC74 package.

### **Advantage of Linear Regulation of LED current**

A key benefit to use a constant-current LED lamp driving is the ability to measure the change in LED lamp current. Through series configuration of the LEDs, current matching is guaranteed.

Electromagnetic Interference (EMI) is minimized with linear regulation methods. Therefore designing with the BCR450 allows faster time to market, system integration and qualification.

Additional filters or shielding required to suppress unwanted electromagnetic radiation are therefore not necessary.

Furthermore, the linear- mode BCR450 does not need a switching inductor. By eliminating the inductor required for a switching design, overall cost is reduced.

Given the rapidly increasing DC power efficiency / efficacy of modern LEDs, a switch-mode driver is often not required to meet overall system DC energy efficiency requirements.

The BCR450 can be used with an external power transistor (boost transistor) for 1/2 W and 1 W LEDs, which helps the lighting designer to realize a low cost, EMI-free solution in a small area, while reducing the power dissipation in the BCR450 itself.

This modular approach to driver design - using BCR450 in “stand alone” mode for currents up to 85 mA, and in “boost” mode with an external transistor for currents over 85 mA - lets the designer use a building- block approach to different LED lighting designs, enabling the designer to use a common core LED driver (BCR450) for multiple designs, adding a “boost” transistor where necessary. This approach can simplify logistics and reduce overall costs.

### Features

- Voltage drop across sense resistor only 0.12 V - 0.15 V; low side current sensing
- Maximum operation voltage: 27 V
- Over voltage protection
- Over current protection
- Temperature shut down mechanism
- Extremely precise bandgap voltage reference
- Maximum operating output current: 85 mA
- Maximum LED current of 2.5 A possible by using external transistors (boost transistors)
- Digital On/Off switch
- PWM control for LED brightness possible
- Minimum external component required (only one current sense resistor)
- Small 6-pin package TSOP6 / SC74
- Low shutdown current: <50 nA typ. at operational voltage range

### Applications

- LED Controller for industrial applications (not qualified for automotive applications)
- General purpose constant current source
- General purpose constant current LED driver
- General illumination, e.g. Halogen Retrofit
- Residential architectural and industrial commercial lighting for indoor and outdoor
- Decorative and entertainment lighting
- Backlighting (illuminated advertising, general lighting)
- Display backlight where high brightness is required e.g. TFT
- Reading lamps (aircraft, car, bus)
- Substitution of micro incandescent lamps
- Signage, Gasoline Canopies, Beacons, Hotel Lighting
- Signal and symbol luminaries for orientation
- Marker lights (e.g. steps, exit ways, etc.)

## 2 Pin description

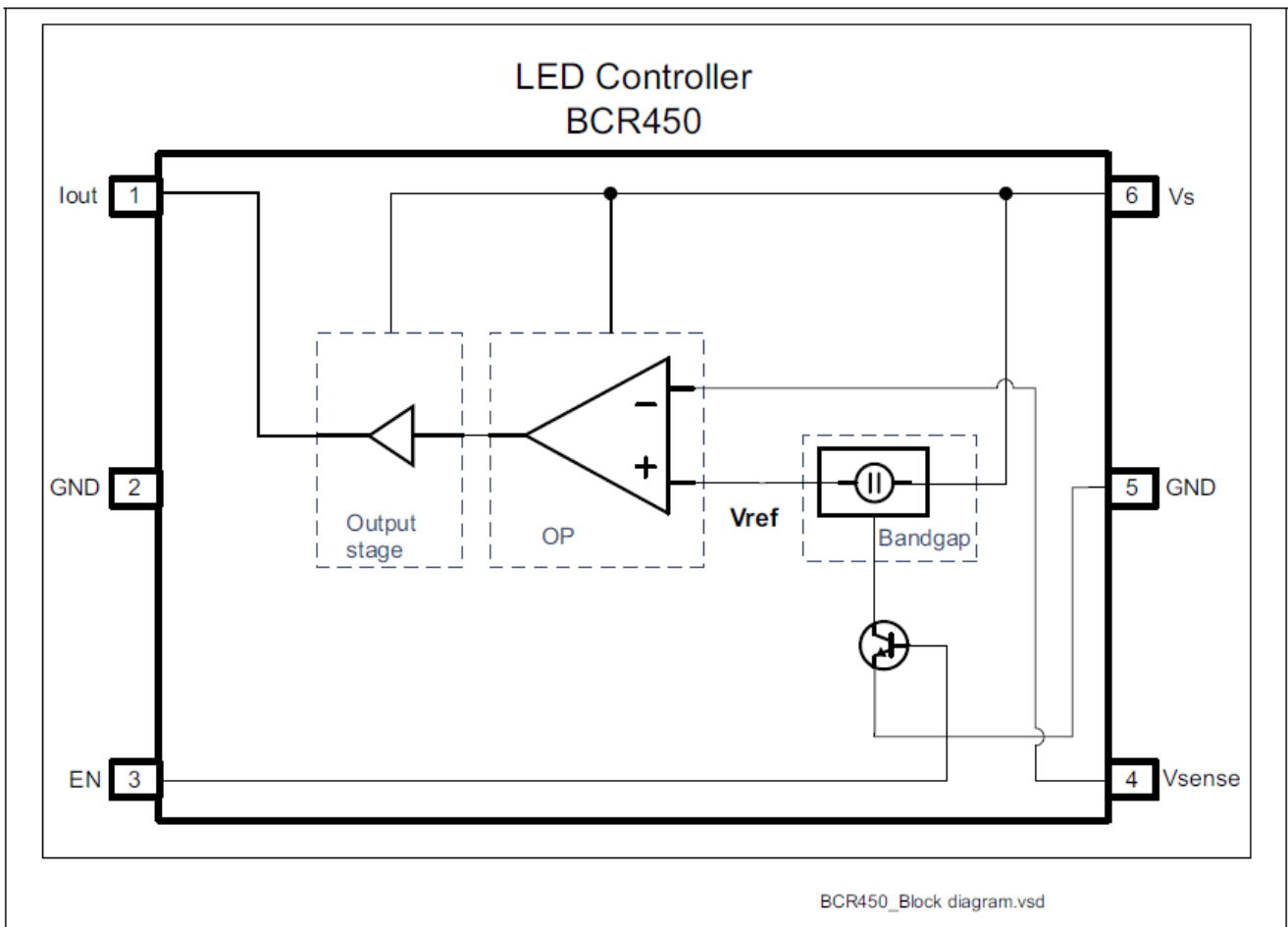

Figure 1 BCR450 block diagram

Table 1 Pin description

Pin number	Pin Symbol	Function
1	$I_{out}$	Controlled output current to drive LEDs
2	$GND$	IC ground
3	$EN$	Power On control voltage pin (PWM input)
4	$V_{sense}$	Sense control voltage pin for internal feedback mechanism
5	$GND$	IC ground
6	$V_s$	Supply voltage

### 3 Application Board

The application board is designed to test the BCR450 with additional external “booster” transistors for high current, high brightness LEDs. 3 LEDs are “stacked” in series, which guarantees the matching of the LED current.

An optional Reverse Polarity Protection (RPP) based on Infineon Schottky Diodes BAS3010A-03W is provided on the application board to avoid inverting the inputs when connecting the DC power plug.

The MCPCB (Metal Clad Printed Circuit Board) for the current application contains only one diode. The board incorporates two power transistors (boost transistors) to minimize thermal problems in high current high voltage applications. To distribute the hot spots on PCB, a cost effective solution could be the use of some Infineon BC817SU transistors in parallel.

Due to the fact that the EN Line of the application board is directly connected to the supply voltage a 270 k $\Omega$  resistor is inserted in series to the EN pin of the IC to protect that pin against higher voltages than the permitted 5 V.

A supply voltage of 8 V - 27 V may be applied and depending on the resulting power dissipation a LED current up to 1 A can be realized.

However the booster transistor requires a minimum of ~0.5 V from collector-to-emitter to operate properly. The controller BCR450 has to deliver a very small driver current due to the  $h_{FE}$  of the power transistor, which drastically reduces the power dissipation in the BCR450 IC.

The temperature of the LED is sensed by the BCR450 via two capacitors operating as thermal bridges, which are connected between the ground plane of the IC and one LED. If the ground plane heats up, the BCR450 will also warm up and if the BCR450's chip temperature exceeds 170 °C (typically), the internal temperature shut down will become active and reduce the LED current.

Based on the enable input, the IC can be switched on or off or a PWM signal can be applied, making PWM dimming possible via controlling the output current  $I_{out}$ .

Due to the fact that LED junction temperatures must be kept below their maximum ratings in order to ensure long LED lifetime, the PCB is manufactured as a metal-clad-circuit board (MCPCB). Flex-Circuit material (DuPont “Kapton”<sup>®</sup>) is attached with adhesive (DuPont “LF”<sup>®</sup>) low cost “3003” series aluminium sheet for the circuit board design.

The aluminium back-plate of the PCB serves as a heat sink for the LEDs, the LED driver IC BCR450 and booster transistor. Only one side of the dielectric has traces or metallization on it. A cross-section diagram of the circuit is given in [Figure 3](#). Note the thin dielectric layer (flex-circuit) of 0.05 mm thickness minimizes thermal resistance, permitting heat to flow from the high power LEDs and circuit components into the aluminium base plate relatively easily.

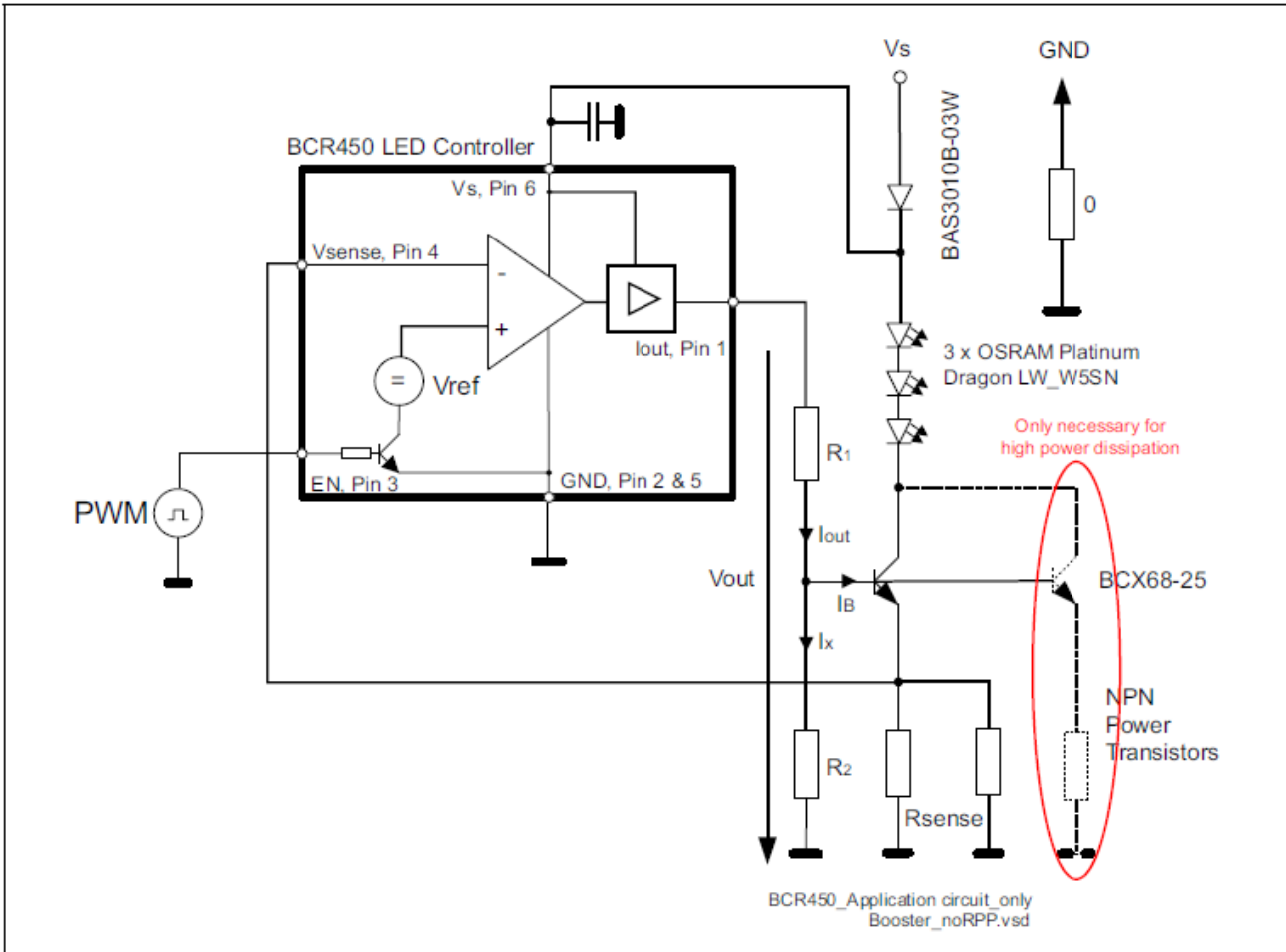

Figure 2 Application circuit with booster transistors

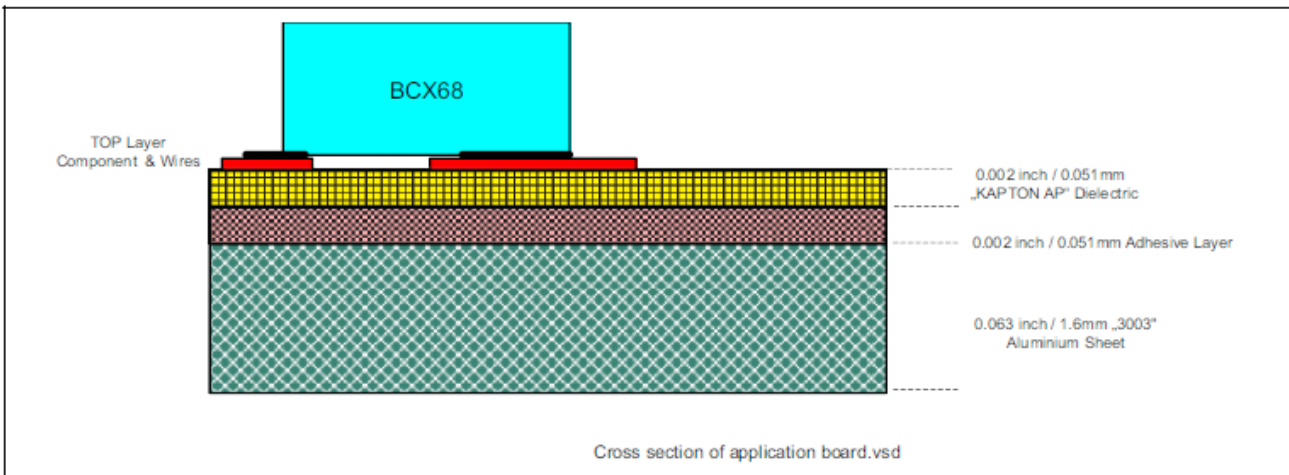

Figure 3 Cross section of the MCPCB



## OSRAM Platinum Dragon

**Table 2** Technical key parameters of OSRAM Platinum Dragon

Symbol	Min.	Typ.	Max.	Value
$V_F$	2.9	3.6	4.3	V
$I_F$	100		1000	mA
$R_{thJS}$		11		K/W
$R_{tot}$		4.6		W

## 4 The BCR450 in “boost” operation for high brightness LEDs

### 4.1 Calculation of the base voltage divider

Assuming an application with one power transistor BCX68-25 and an  $I_{LED}$  current of 350 mA.  $h_{FE}$  is typically 250.

$$V_{sense} \sim 150 \text{ mV}$$

$$V_S = 12 \text{ V}$$

Referring to [Figure 2](#)

$$\rightarrow \text{base current of the transistor: } I_B = I_{LED} / h_{FE} = 1.4 \text{ mA}$$

Assuming  $I_X$  should be 5 times higher than  $I_{Btot}$

$V_{BE}$  of the power transistor is  $\sim 0.56 \text{ V}$  (if transistor is heated up)

$$\rightarrow I_{out} = I_B + I_X = I_B + 5 \times I_B = 6 I_B$$

$$\rightarrow V_{R2} \sim 0.56 \text{ V} + V_{sense} = 0.56 \text{ V} + 0.15 \text{ V} = 0.71 \text{ V}$$

$$\rightarrow R_2 = 0.71 \text{ V} / 5 \times I_B = 0.71 \text{ V} / 7 \text{ mA} = 101.4 \Omega; \text{ Next value E24: } 100 \Omega$$

Assuming  $V_{out} = 8 \text{ V}$ , which results in  $4 \text{ V } V_{CE}$  at the output stage (between pin 6 and pin 1 of the BCR450).

Lower  $V_{CE}$  helps to minimize the power dissipation in the IC ( $V_{CE} \times I_{CE}$ ). A  $V_{CE}$  up to approx.  $1 \text{ V}$  is feasible for boost operation.

$$\rightarrow V_{R1} = V_{out} - 0.71 \text{ V} = 7.29 \text{ V}$$

$$\rightarrow R_1 = V_{R1} / 6 \times I_B = 7.29 \text{ V} / 8.4 \text{ mA} = 867.86 \Omega; \text{ Next value E24: } 820 \Omega$$

Providing two power transistors results in the same resistor values for the base voltage divider. Note, that the values of the bias circuit are not critical

## 4.2 How to calculate and choose the booster transistor

The external boost transistor is the key component to get a design which has a good efficiency in terms of power consumption, size of the PCB and cost.

1. At first we have to set the supply voltage range  $V_{\text{supply}}$
2. Determine the desired LED current  $I_{\text{LED}}$
3. Set the number of stacked diodes; this is very important, because the residual voltage will be dropped down at the booster transistor. Be sure to allow for at least 0.5 V across the collector- emitter of the booster transistor for proper operation
4. Depending on the total power dissipation it could be necessary to use 2 transistors in parallel, which is supported in the application board
5. Sufficient heat sink area should be provided for the power transistors

Maximum Power Dissipation calculation as an example:

$$V_{\text{supply}} = 12 \text{ V}$$

$$I_{\text{LED}} = 350 \text{ mA}$$

3 Platinum Dragon LEDs with a  $V_{\text{Fmin}} = 2.9 \text{ V}$  in series

$$= 150 \text{ mV typ.}$$

$V_{\text{sense}}$

$$= 3 \times 2.9 \text{ V} = 8.7 \text{ V}$$

$V_{\text{F total}}$

This results in a value of  $R_{\text{sense}}$  of

$$R_{\text{sense}} = V_{\text{sense}} / I_{\text{LED}} = 0.15 \text{ V} / 350 \text{ mA} = 0.43 \Omega \text{ (could be realized } 1.8 \Omega \text{ and } 0.56 \Omega \text{ in parallel)}$$

$$V_{\text{CEtransistor}} = 12 \text{ V} - 0.15 \text{ V} - 8.7 \text{ V} = 3.15 \text{ V}$$

$$P_{\text{tot}} = V_{\text{CE}} \times I_{\text{LED}} = 3.15 \text{ V} \times 350 \text{ mA} = 1103 \text{ mW}$$

If the Total Power Dissipation will exceed 1500 mW, adequate cooling provided by a properly sized heat sink is necessary.

## 4.3 Calculation with two transistors

The value of the sense resistor of each power transistor is half of that as compared to a design using a single booster transistor.

*Note: Both resistors should have the same value of the sense resistor to ensure both boost transistors have the same collector currents and share the power dissipation burden equally.*

Regarding the power dissipation, each transistor will dissipate half of power as well.

$$R_{\text{sense}} = V_{\text{sense}} / I_{\text{LED}} / 2 = 0.15 \text{ V} / 175 \text{ mA} = 0.86 \Omega \text{ (could be realized } 5.6 \Omega \text{ and } 1 \Omega \text{ in parallel)}$$

$$P_{\text{tot one transistor}} = V_{\text{CE}} \times I_{\text{LED}} / 2 = 3.15 \text{ V} \times 175 \text{ mA} = 551.3 \text{ mW}, \text{ which results in enough margin for the design}$$

Three transistor types are recommended

**Table 3 Recommended transistors**

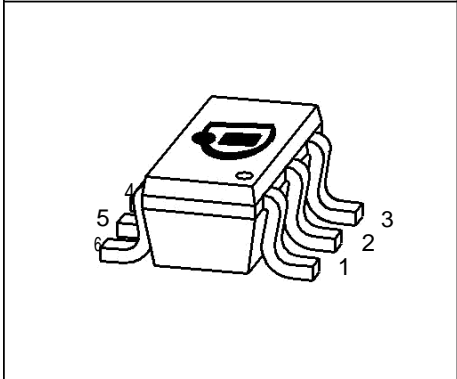
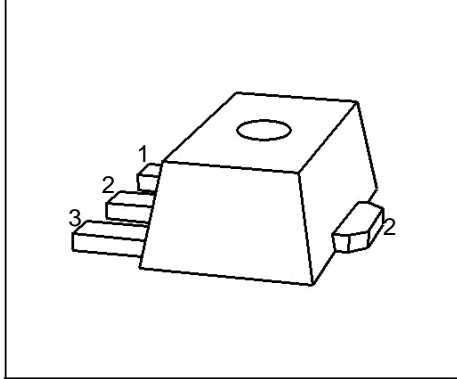
SC74	SOT89	
		
2.9 x 1.6 x 1.1 mm	4.5 x 2.5 x 1.5 mm	
BC817SU $P_{tot} = 1000 \text{ mW max.}$ $I_{Cmax} = 500 \text{ mA}$ 45 V breakdown (C-E) Thermal Resistance <sup>1)</sup> < 50 K/W	BCX55-16 $P_{tot} = 1000 \text{ mW max.}$ $I_{Cmax} = 1000 \text{ mA}$ 60 V breakdown (C-E) Thermal Resistance < 20 K/W	BCX68-25 $P_{tot} = 1500 \text{ mW max.}$ $I_{Cmax} = 1000 \text{ mA}$ 20 V breakdown (C-E) Thermal Resistance < 20 K/W

1) Thermal resistance is device Junction to package Soldering point ( $R_{thJS}$ )

As mentioned previously, if the power dissipation exceeds the maximum level of all transistor packages, it is necessary to split the power consumption by using two transistors. Without any heat sink two BCX68-25 should be used in order to handle  $P_{tot} = V_{CE} \times I_{LED}$ . Of course, power consumption issues in the transistor could be relaxed if the number of LEDs used in the stack is increased.

*Note: Stacking more LEDs, if possible, reduces the collector-emitter voltage  $V_{CE}$  across the boost transistor(s), thereby decreasing the power dissipation in the boost transistor(s). But one must ensure that the boost transistors have at least 0.5 V across their collector-emitter connections under all anticipated operating conditions to ensure they operate properly.*

It is also possible to reduce the junction temperature by providing large copper areas on the PCB connected to the collector of the transistor.

If the junction temperature does not exceed 150 °C at the highest ambient temperature, a smaller booster transistor could also be used (e.g. BC817SU).

Three transistors BC817SU with SC74 packages are recommended in order to avoid hot spots on the PCB by splitting up the power dissipation between multiple packages, e.g. this approach “spreads out the heat”.

Nevertheless, the power dissipation in the BCR450 is very low due to the fact that the output current of the BCR450 when operated with an external “boost” transistor is calculated as  $I_{out} = I_{LED} / h_{FE}$ .

In other words, in the “boost” configuration, the current that the BCR450 needs to provide, is the LED current, divided by the DC current gain of the boost transistor(s).

Therefore in this case, the BCR450 acts as a ‘controller’ with very low power dissipation, and does not require any additional effort in terms of cooling, as the largest part of the power dissipation burden has been shifted to the external boost transistor(s).

#### 4.4 Calculation of the Power Dissipation

We use the example from [Chapter 4.2](#). Only one power transistor will be used.

$$P_{\text{tot (only one transistor)}} = U_{\text{CE}} \times I_{\text{LED}} = 3.15 \text{ V} \times 350 \text{ mA} = 1103 \text{ mW}$$

In most of the case the  $R_{\text{thSA}}^{1)}$  is not known. Therefore the only method to determine the junction temperature of the transistor is to measure the temperature of the solder point  $T_{\text{S}}$ .

$$T_{\text{J}} = T_{\text{S}} + P_{\text{tot}} \times R_{\text{thJS}}$$

If the customer knows the thermal resistance of the board one can easily calculate the temperature of the solder point  $T_{\text{S}}$ , too.

$$T_{\text{S}} = T_{\text{A}} + P_{\text{tot}} \times R_{\text{thSA}}$$

A combination of both formulas results in

$$T_{\text{J}} = T_{\text{A}} + P_{\text{tot}} \times (R_{\text{thJS}} + R_{\text{thSA}})$$

#### 4.5 Using BCX68-25

$$P_{\text{tot}} = 1.5 \text{ W } (T_{\text{S}} = 120 \text{ }^{\circ}\text{C})$$

$$I_{\text{max}} = 1 \text{ A}$$

$$K_{\text{thJS}} = 20 \text{ K/W (SOT89)}$$

$$P_{\text{tot (only one transistor)}} = 1103 \text{ mW}$$

**Table 4**  $P_{\text{tot (only one transistor)}}$

$T_{\text{A}}$	$T_{\text{J}} @ R_{\text{thSA}} = 20 \text{ K/W}$	$T_{\text{J}} @ R_{\text{thSA}} = 36 \text{ K/W}$	$T_{\text{J}} @ R_{\text{thSA}} = 85 \text{ K/W}$
25 °C	69.1 °C	86.8 °C	140.8 °C
65 °C	109.1 °C	126.8 °C	180.8 °C <sup>1)</sup>
85 °C	129.1 °C	146.8 °C	200.8 <a href="#">page12</a> °C <sup>1)</sup>

1) Values exceed the maximum junction temperature of 150 °C. The transistor requires additional heat sink or a design with two transistors in parallel.

**Table 5**  $P_{\text{tot (each transistor)}} = 551.3 \text{ mW}$ ; two power transistors in parallel

$T_{\text{A}}$	$T_{\text{J}} @ R_{\text{thSA}} = 20 \text{ K/W}$	$T_{\text{J}} @ R_{\text{thSA}} = 36 \text{ K/W}$	$T_{\text{J}} @ R_{\text{thSA}} = 85 \text{ K/W}$
25 °C	47.1 °C	55.9 °C	82.9 °C
65 °C	87.1 °C	95.9 °C	122.9 °C
85 °C	107.1 °C	115.9 °C	142.9 °C

1) Thermal resistance between soldering point and ambient

#### 4.6 Using two BCX55-16

$$\begin{aligned}
 P_{\text{tot}} &= 1 \text{ W} \\
 I_{\text{max}} &= 1 \text{ A} \\
 K_{\text{thJS}} &= 20 \text{ K/W (SOT89)}
 \end{aligned}$$

**Table 6**  $P_{\text{tot}}$  (each transistor)= 551.3 mW; two power transistors in parallel

$T_A$	$T_J @ R_{\text{thSA}} = 20 \text{ K/W}$	$T_J @ R_{\text{thSA}} = 36 \text{ K/W}$	$T_J @ R_{\text{thSA}} = 85 \text{ K/W}$
25 °C	47.1 °C	55.9 °C	82.9 °C
65 °C	87.1 °C	95.9 °C	122.9 °C
85 °C	107.1 °C	115.9 °C	142.9 °C

#### 4.7 Using BC817SU

This is the most cost effective solution

*Note:  $h_{FE}$  of the BC817SU degrades at 500 mA by using only one transistor*

$$\begin{aligned}
 P_{\text{tot}} &= 1 \text{ W} \\
 I_{\text{max}} &= 0.5 \text{ A} \\
 K_{\text{thJS}} &= 50 \text{ K/W (SC74)}
 \end{aligned}$$

**Table 7**  $P_{\text{tot}}$  (each transistor)= 551.3 mW; two power transistors in parallel

$T_A$	$T_J @ R_{\text{thSA}} = 20 \text{ K/W}$	$T_J @ R_{\text{thSA}} = 36 \text{ K/W}$	$T_J @ R_{\text{thSA}} = 85 \text{ K/W}$
25 °C	63.6 °C	72.4 °C	99.5 °C
65 °C	103.6 °C	112.4 °C	139.5 °C
85 °C	123.6 °C	132.4 °C	159.5 °C

### 5 Calculation of the maximum number N of stacked diodes with identical $V_F$ in boost mode

- Determine the supply voltage
- Set the minimum  $V_{CE}$  of the booster transistor. BCX68-25 power transistor works well down to  $V_{CE} = 0.3 \text{ V}$  if  $I_{CE}$  is below 1000 mA
- Calculate the available voltage over the LEDs  
 $V_{LED} = V_{\text{supply}} - V_{\text{sense}} - V_{CE} = V_{\text{supply}} - 0.15 \text{ V} - 0.5 \text{ V}$  ( $V_{CE} = 0.5 \text{ V}$  with additional 0.2 V margin)
- $N = V_{LED} / V_F$ ; it is recommended to round down the nearest integer value

Example:

$$V_{F \text{ max}} = 4.3 \text{ V (OSRAM Platinum Dragon)}$$

$$V_{\text{supply}} = 15 \text{ V} \rightarrow V_{LED} = 14.35 \text{ V}$$

$$\rightarrow N = 14.35 \text{ V} / 4.3 \text{ V} \sim 3$$

## 6 Using a heat sink to decrease solder point temperature $T_S$ of the LEDs and the booster transistor

If the MCPCB is connected with a heat sink using SK 76 profile, the solder point temperature  $T_S$  of the boost transistor would be decreased by 45 °C.

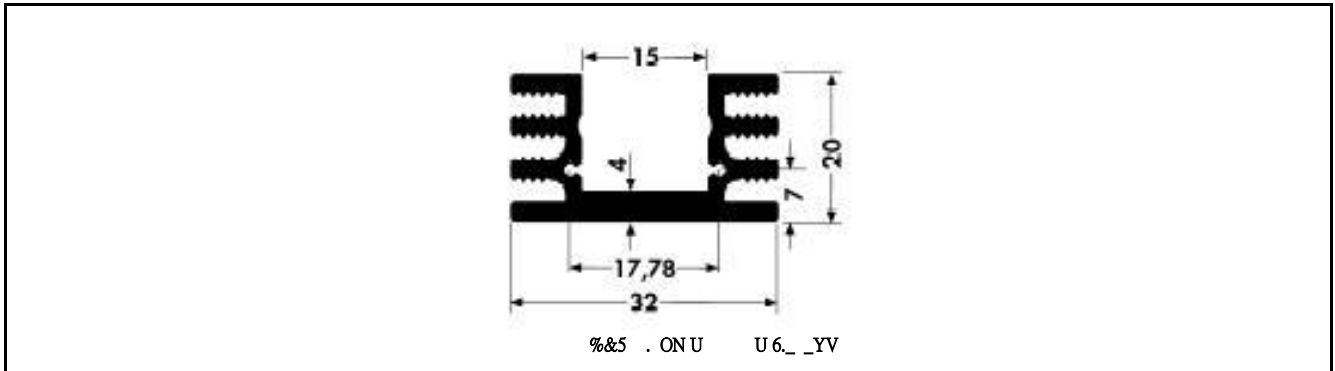

**Figure 4 SK 76 Profile (all readings in mm);  $R_{th} = 8 \text{ K/W}$**

$$V_S = 12 \text{ V}$$

$$I_{LED} = 350 \text{ mA}; V_F \sim 2.9 \text{ V}$$

$$T_A = 25 \text{ °C}$$

$$K = 20 \text{ K/W}$$

$$K_{thJS \text{ Trans}}$$

$$K = 11 \text{ K/W}$$

$$K_{thJS \text{ LED}}$$

$$SK \ 76 : 37.5 \text{ mm long (37.5 x 32 x 20mm)} \Rightarrow R_{th} = 8 \text{ K/W}$$

**Table 8 Current MCPCB Board**

	Booster Transistor	LED 1	LED 2	LED 3
$T_S$ (°C)	119.0	100.0	101.0	99.5
$P_{tot}$ (W)	1.11	1.00	1.02	0.99
$T_J$ (°C)	141.1	111.0	112.2	110.4
$R_{thSA}$ (K/W)	85.0	75.0	74.9	75.5

**Table 9 Using MCPCB Board mounted on a SK 76 cooling element**

	Booster Transistor	LED 1	LED 2	LED 3
$T_S$ (°C)	74	61	58	60.5
$P_{tot}$ (W)	1.11	1.05	1.06	1.03
$T_J$ (°C)	96.1	72.6	69.7	71.8
$R_{thSA}$ (K/W)	44.3	34.2	31.0	34.6

$$\rightarrow T_{J \text{ max Trans}} = 150 \text{ °C}$$

$$\rightarrow T_{J \text{ max Trans}} - T_{J \text{ Trans on SK76}} = 150 \text{ °C} - 96.1 \text{ °C} = 53.9 \text{ °C}$$

The ambient temperature  $T_A$  could be increased by 53.9 °C (25 °C + 53.9 °C = 78.9 °C) until  $T_J$  exceeds 150 °C. This results in a  $T_J$  of the LEDs of 125 °C.

## 7 How to use the BCR450 in “stand alone” mode

--not supported according to the application board--

The application needs only one sense resistor for operation

Assuming again the worst case scenario

Using e.g. OSRAM - Advanced Power Top LED

**Table 10 OSRAM Advanced Power Top Key technical data**

Symbol	Min.	Typ.	Max.	Unit
$V_F$	2.9	3.6	4.1	V
$I_F$	30		250	mA
$R_{thJS}$		40		K/W
$P_{tot}$		650		mW

$V_{Ftyp}$  = 3.6 V  
 $I_{LED}$  = 70 mA  
 $V_S$  = 12 V

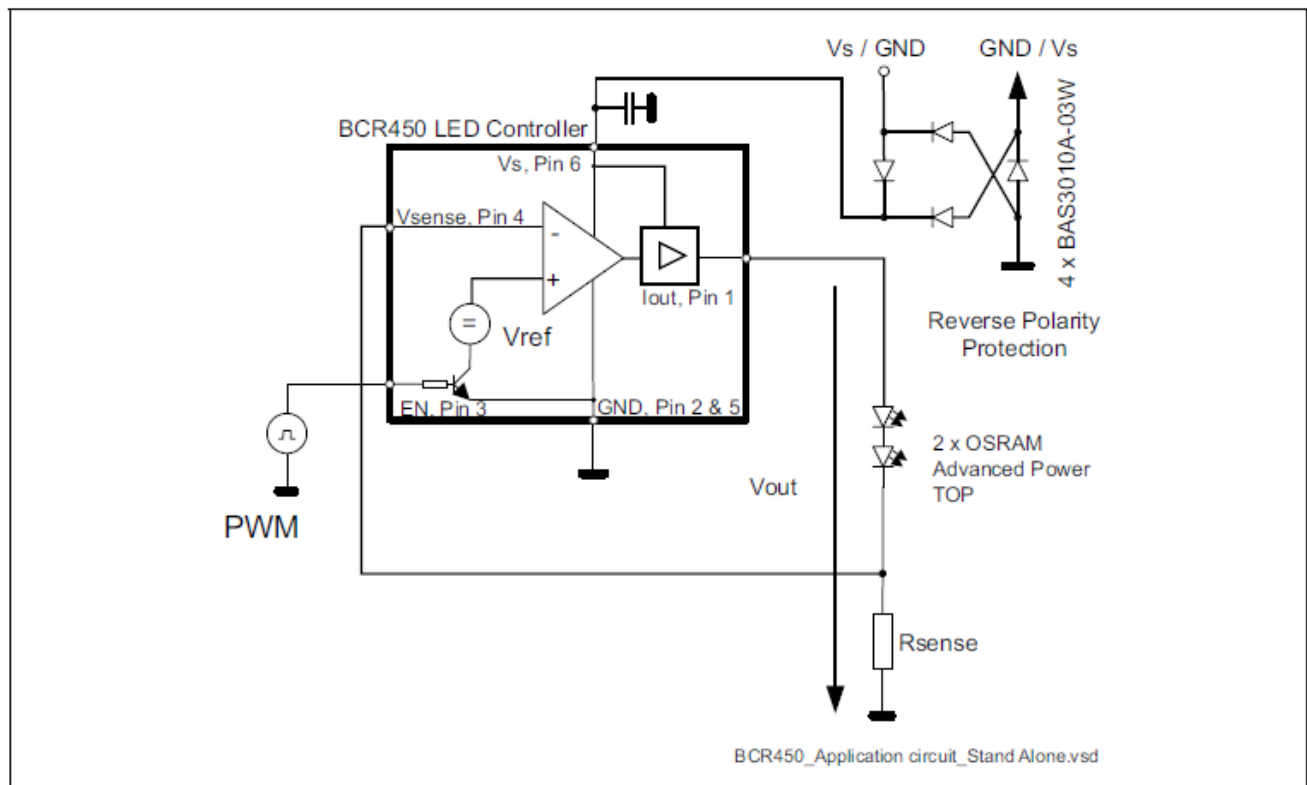

2 LEDs stacked in series  $V_{LED}$   
 $= 2 \times 3.6 \text{ V} = 7.2 \text{ V} \sim V_{out}$

**Figure 5 Application circuit BCR450 in “stand alone” mode**

The curves below are specified at  $T_A = 25\text{ }^\circ\text{C}$

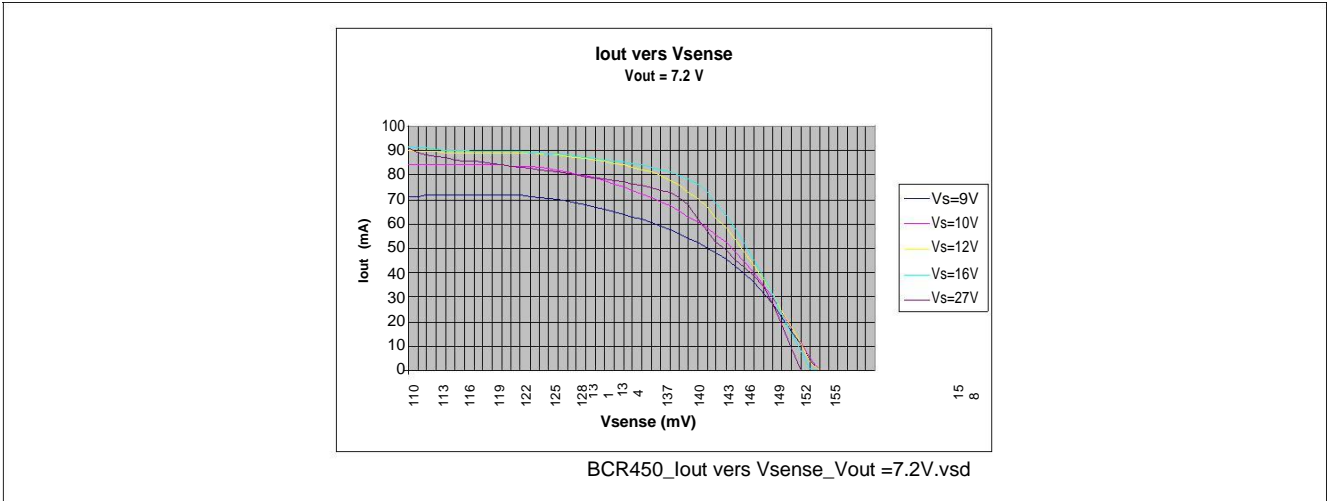

Figure 6  $I_{out}(V_{sense}); V_{out}=7.2\text{ V}$

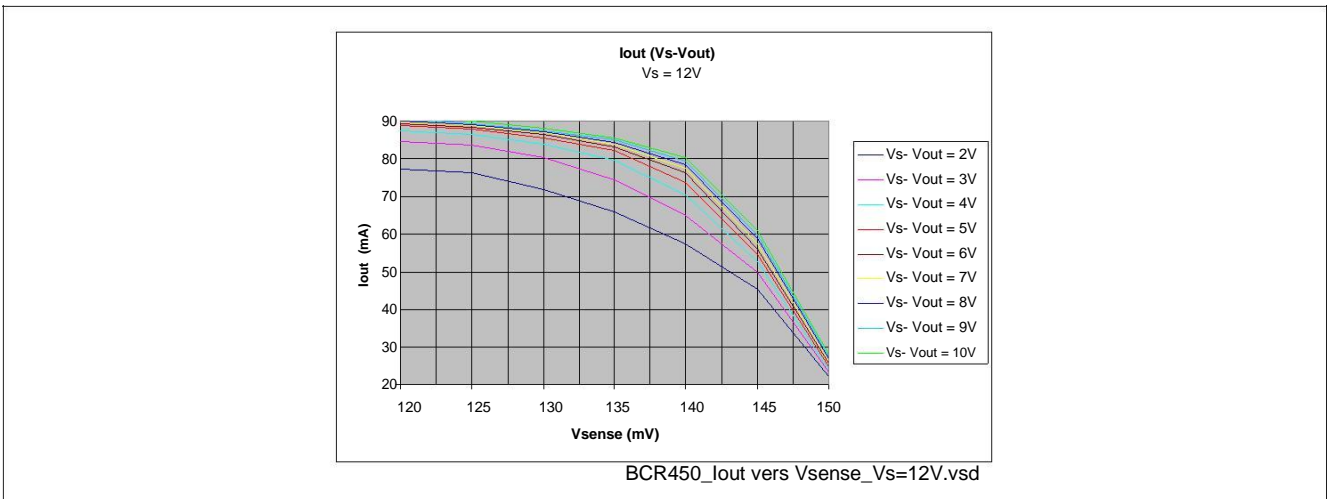

Figure 7  $I_{out}(V_{sense}); V_S = 12\text{ V}$

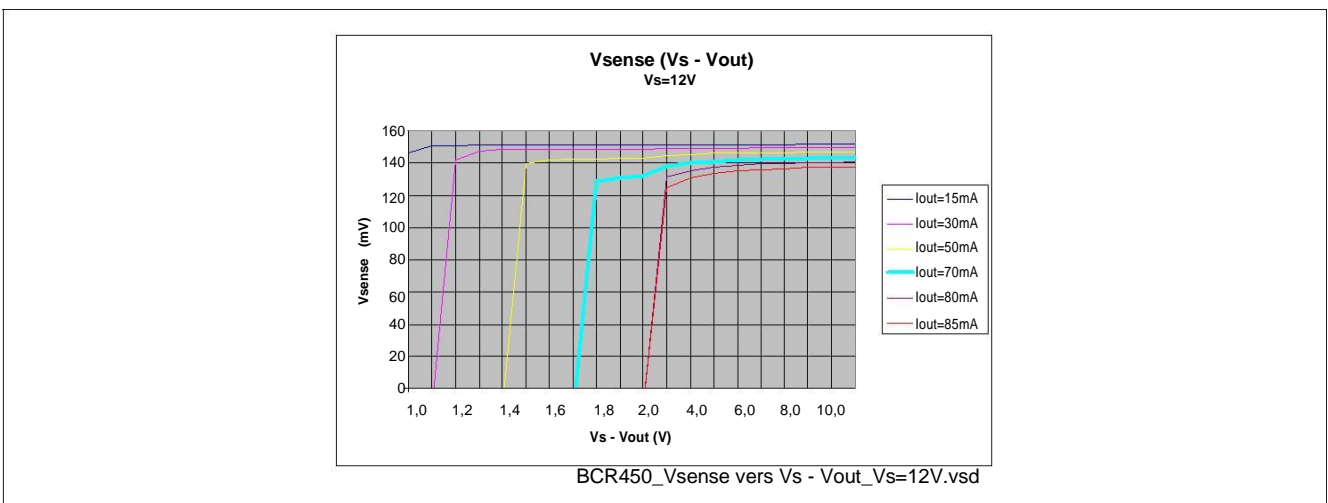

Figure 8  $V_{sense}(V_S - V_{out}); V_S = 12\text{ V}$



It must be pointed out that there are criteria a designer should be aware:

1.  $V_S - V_{out}$  should not fall below a certain value e.g. 70 mA: ~ 2.5 V (see [Figure 8](#)). If  $V_F$  tends to maximum specification value, enough overhead regarding supply voltage should be guaranteed
2. The minimum  $V_F$  of the LEDs results in increasing the power dissipation of the output stage transistor in the IC

For a stable linear regulation we use a  $V_{sense}$  which gives enough margin in order to the control range (see [Figure 6](#) and [Figure 7](#))

Derived from [Figure 6](#)

$$V_S - V_{out} = 12\text{ V} - 7.2\text{ V} = 4.8\text{ V}$$

Results in  $V_{sense} = 141\text{ mV @ } 70\text{ mA}$  (yellow curve)

$$\rightarrow R_{sense} = \frac{V_{sense}}{I_{LED}} \sim 2\ \Omega$$

## 7.1 Worst case scenario regarding power dissipation

Refer to [Figure 9](#)

$$V_{Trans} = V_S - 2 \times V_{Fmin} - V_{sense} = 12\text{ V} - 5.8\text{ V} - 0.141\text{ V} = 6.06\text{ V}$$

$$P_{tot} = 6.06\text{ V} \times 70\text{ mA} = 424\text{ mW}$$

$R_{thSA} = 20\text{ K/W}$  (assuming the  $R_{thSA}$  of an imaginary MCPCB Application Board)

$R_{thJS} = 75\text{ K/W}$  (BCR450 - Thermal resistance - Junction to Solder Point)

$$T_J = T_A + P_{tot} \times (R_{thSA} + R_{thJS}) = T_A + 40.28\text{ K}$$

**Table 11**  $T_J(T_A)$

$T_A$ (°C)	$T_J$ (°C)
25	65.3
65	105.3
85	125.3
105	145.3

## 8 General aspects regarding Overhead Voltage for a given Output current $I_{out}$

$$V_{overhead} = V_{Trans} + V_{sense} = V_S - V_{LED}$$

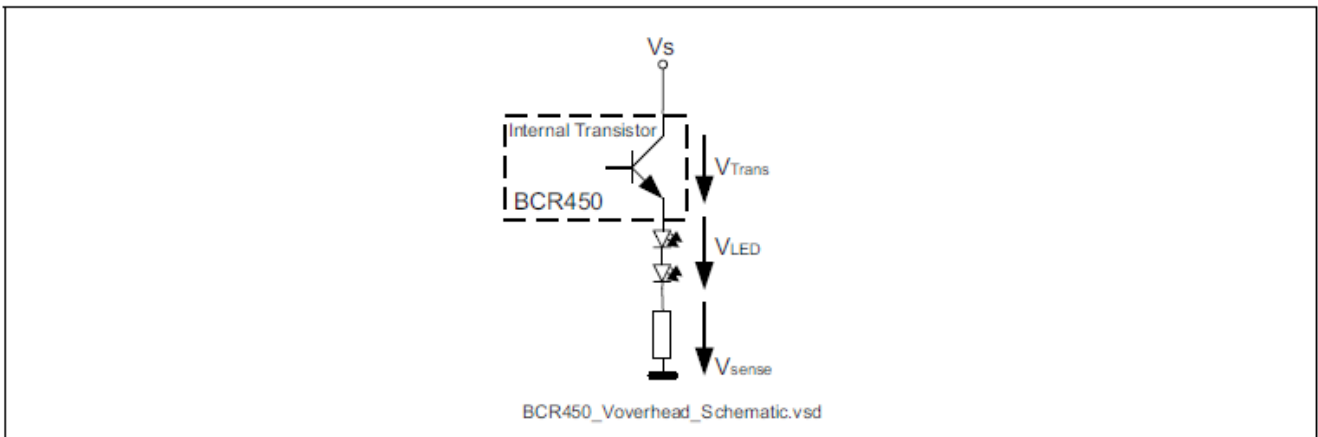

Figure 9  $V_{overhead}$  principle

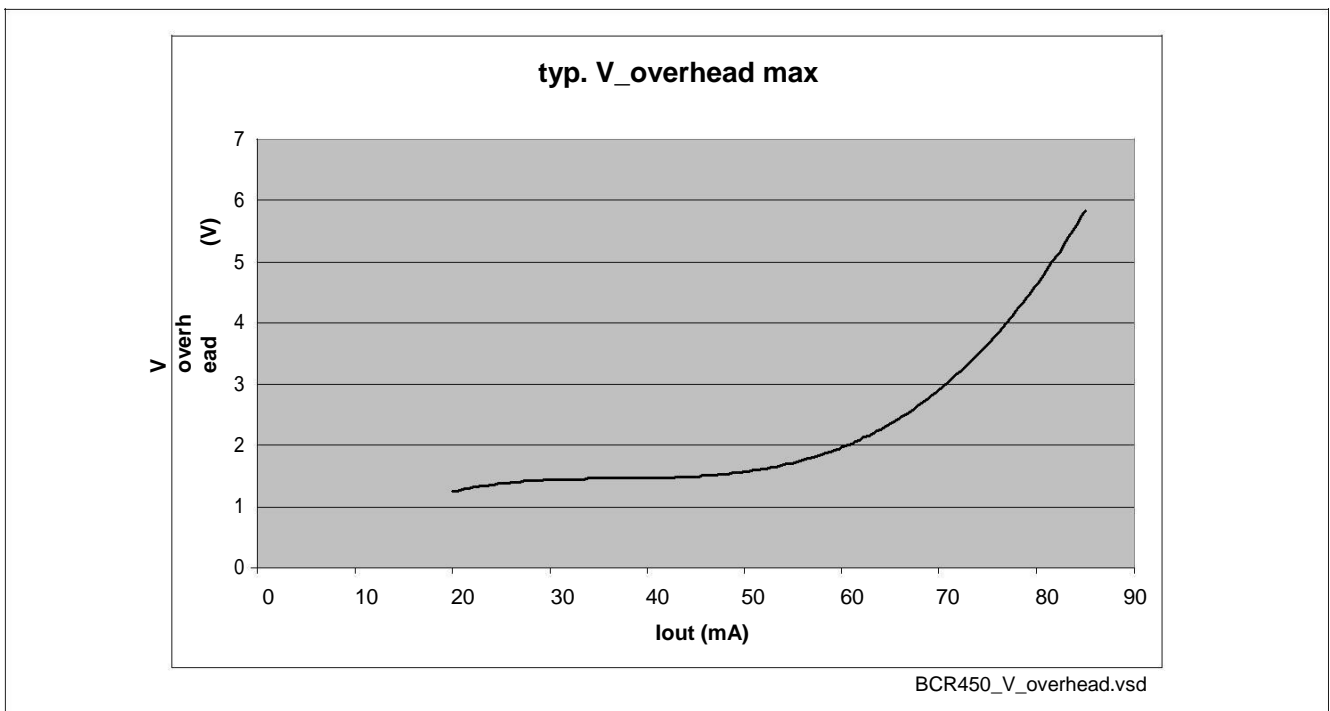

Figure 10  $V_{overhead}(I_{out})$

For a wanted output current  $I_{out}$  of 70 mA one needs approx. 3 V overhead, while  $V_{sense}$  operates in a range of > 130 mV

e.g. 3 diodes with a  $V_F$  of 3 V and 12 V supply voltage

$$\rightarrow 3 \times V_F + V_{overhead} = 9\text{ V} + 3\text{ V} = 12\text{ V}$$

## 9 Calculate PWM frequency and duty cycle

To determine the maximum PWM frequency or a certain PWM duty cycle the knowledge of the rise and fall-times of the BCR450 is necessary

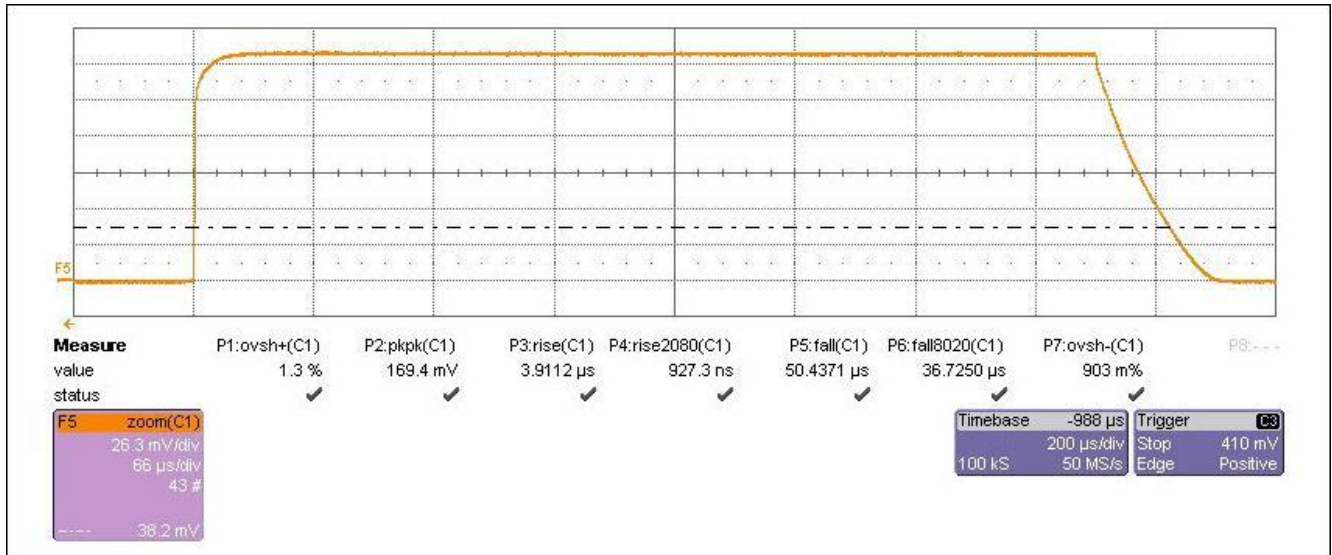

**Figure 11 Response Time**

$T_{on}$ (10-90%)	4 $\mu$ s	Maximum value does not exceed 10 $\mu$ s
$T_{off}$ (90-10%)	50.5 $\mu$ s	Maximum value: 70 $\mu$ s

For the calculation the maximum value of  $T_{on}$  of 10  $\mu$ s should be used

$$(T_{on} / T_{off}) * 100 = t_{duty} \text{ in } \%$$

$$T = (T_{on} + T_{off}) = (T_{on} + T_{on} / t_{duty}) = T_{on} (1 + 100 / t_{duty} (\%))$$

$$F_{PWM} = 1 / T$$

### Maximum frequency according to 1 % duty cycle

$$F_{PWMmax} = 1 / (10 \mu s (1 + 100/1)) = 990 \text{ Hz}$$

### Maximum duty cycle for a given PWM frequency

e.g.  $F_{PWM} = 2 \text{ KHz}$

$$t_{dutymax}(\%) = 100 / ((1 / (F_{PWM} \times T_{on}) - 1))$$

$$t_{dutymax}(\%) = 100 / ((1 / (2 \text{ KHz} \times 10 \mu s) - 1))$$

$$\rightarrow t_{dutymax} = 2.04 \%$$

### Example of PWM- Dimming in boost mode

$$\begin{aligned}
 V_S &= 12 \text{ V} \\
 I_{LED} &= 353 \text{ mA (100\% } t_{duty}) \\
 f_{PWM} &= 300 \text{ Hz}
 \end{aligned}$$

**Table 12 Dimming Range of 2300 : 1**

$T_{duty} (\%)$	$I_{LED} (\text{mA})$
1	0.15
5	17
10	34
20	68
30	108
40	144
50	180
60	214
70	250
80	286
90	320
95	340
100	353

## 10 Measurement setup for the boost mode

In order to set up and evaluate the BCR450, the following components and equipment are needed:

- A sense resistor (typically 0.1  $\Omega$  to 0.5  $\Omega$  depending on the wanted LED current).  
– See [Table 13](#)
- A power transistor (the type depends on the LED current and the maximum power dissipation, see [Table 3](#))
- LED load
- 8 V to 27 V supply
- Enable or PWM- signal
- Digital voltmeter (DVM)

**Table 13 Sense Resistor Selection**

$I_{LED} (\text{mA})$	$R_{sense} (\Omega)$
100	1.5
150	1
350	0.43
500	0.3
700	0.21

## 11 Schematic and Layout

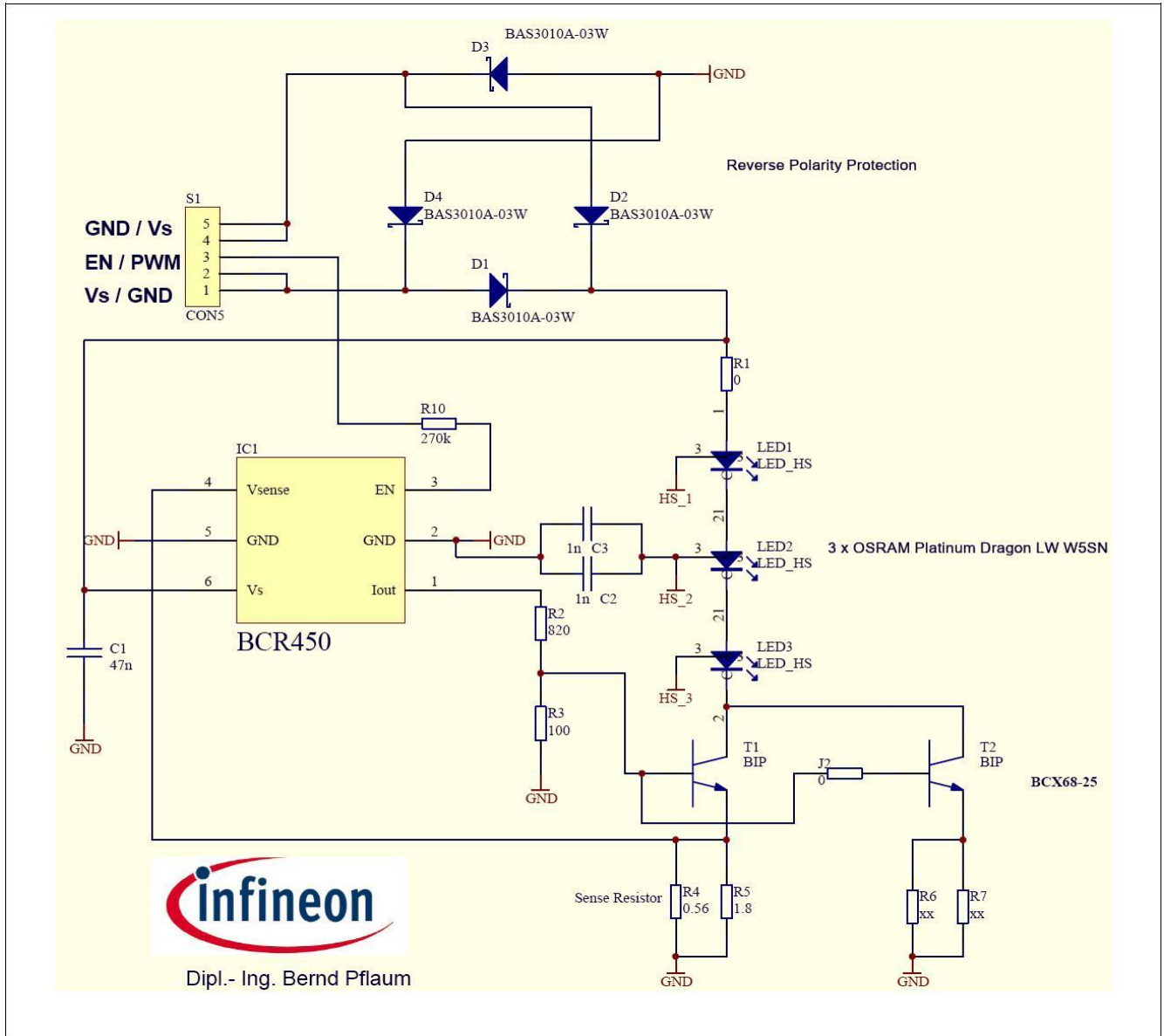

**Figure 12 Board Schematic of High Power LED Application with OSRAM Platinum Dragon**

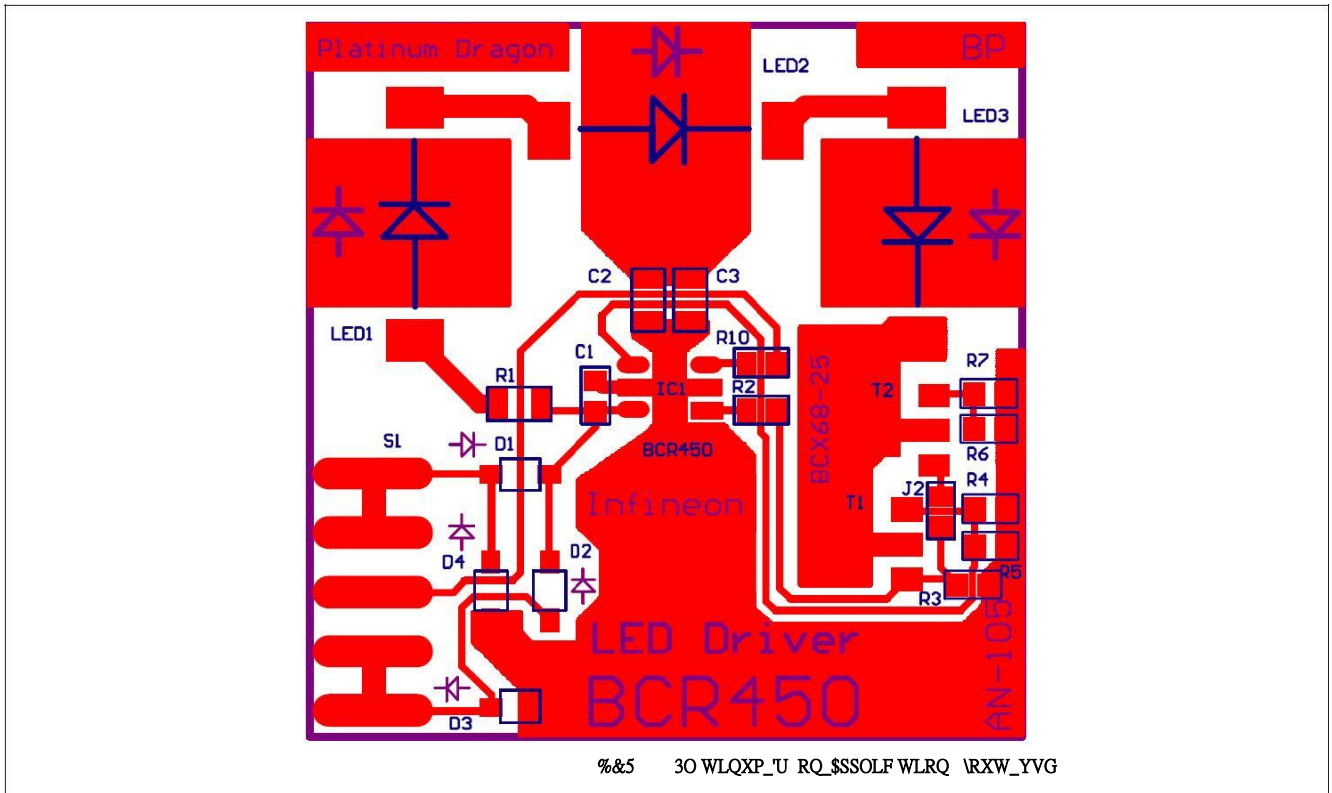

Figure 13 Layout

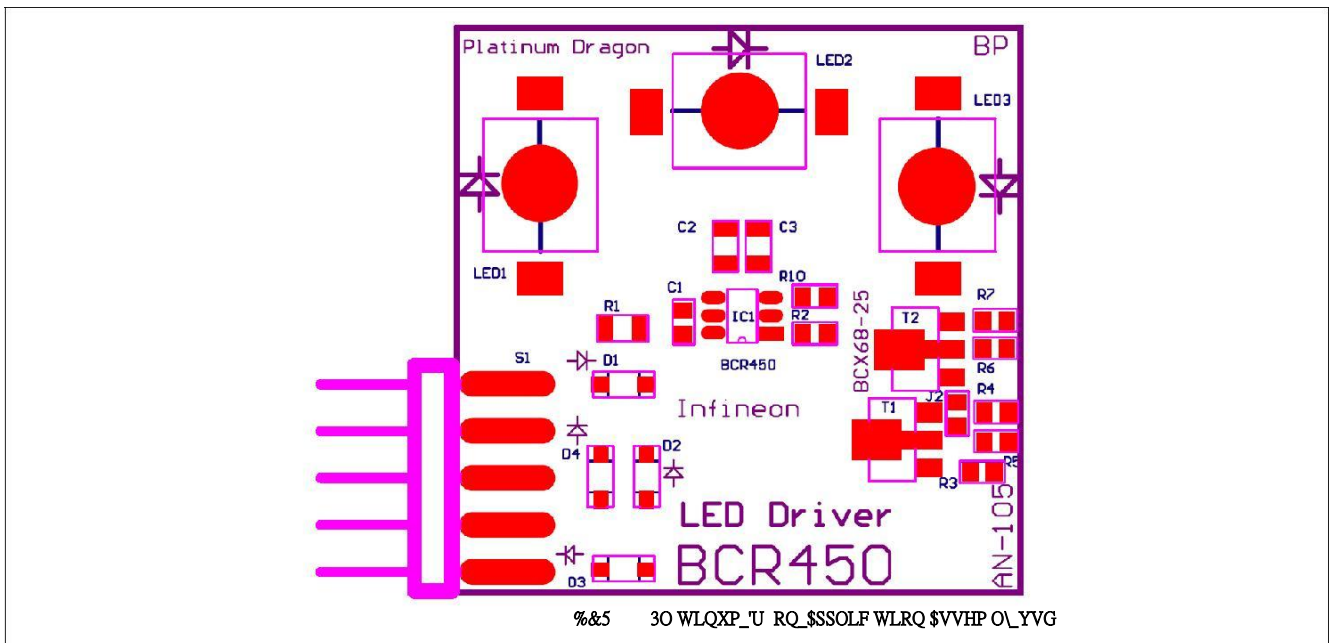

Figure 14 Component Placement Specification

**Table 14 Assembly List**

Name	Value	Package	Function
J2	0 $\Omega$	0603	
R1	0 $\Omega$	0805	
R2	820 $\Omega$	0603	
R3	100 $\Omega$	0603	
R4 <sup>1)</sup>	0.56 $\Omega$	0805	Set LED current
R5 <sup>1)</sup>	1.8 $\Omega$	0603	Set LED current
R6		0603	Only necessary by using a second booster transistor
R7		0603	Only necessary by using a second booster transistor
R10	270 k $\Omega$	0603	
C1	47 nF	0603	
C2	1 nF	0805	For heat sink purposes, optional
C3	1 nF	0805	For heat sink purposes, optional
D1	BAS3010A-03W	SOD323	
D2	BAS3010A-03W	SOD323	Only used in case of RPP circuit
D3	BAS3010A-03W	SOD323	Only used in case of RPP circuit
D4	BAS3010A-03W	SOD323	Only used in case of RPP circuit
IC1	BCR450	TSOP6 / SC74	LED controller
T1	BCX68-25	SOT89	Booster Transistor
T2	BCX68-25	SOT89	Not used in the application board
S1	CON5	EDGE_CON_TOP	DC plug
LED1	LW W5SN	Platinum Dragon	1W LED, white
LED2	LW W5SN	Platinum Dragon	1W LED, white
LED3	LW W5SN	Platinum Dragon	1W LED, white

1) Value is valid only by using one boost transistor

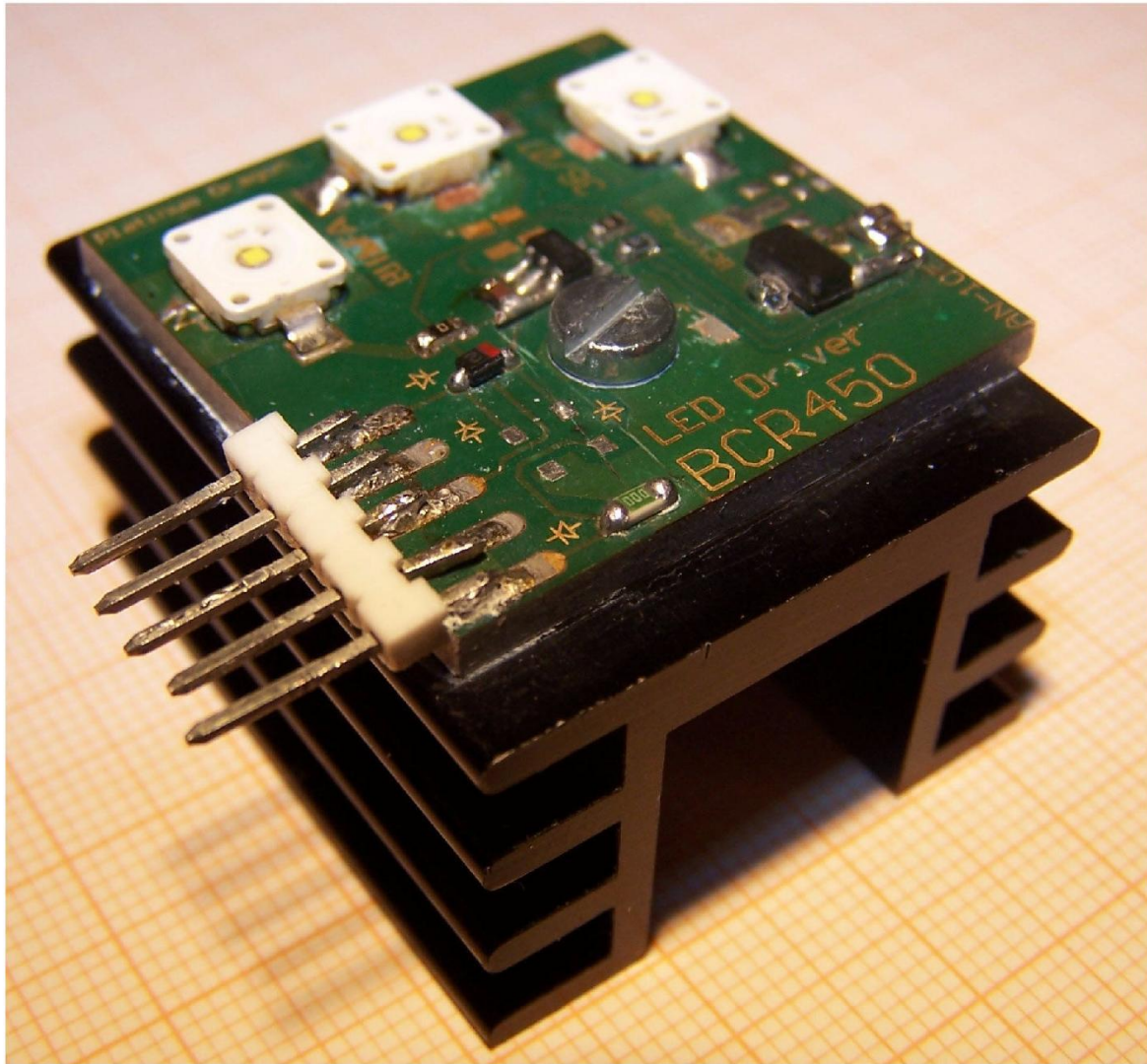

Figure 15 Photograph of the Application of BCR450 with OSRAM Platinum Dragon LEDs and additional cooling element SK 76



## 12 Package Outline

The BCR450 is assembled in a TSOP6 or SC74 Package

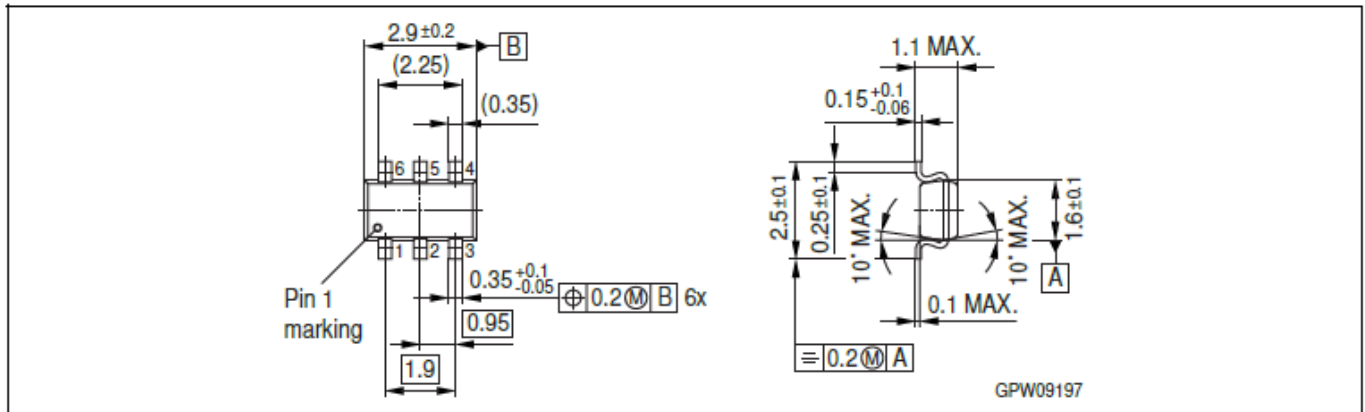

Figure 16 Package Outline SC74

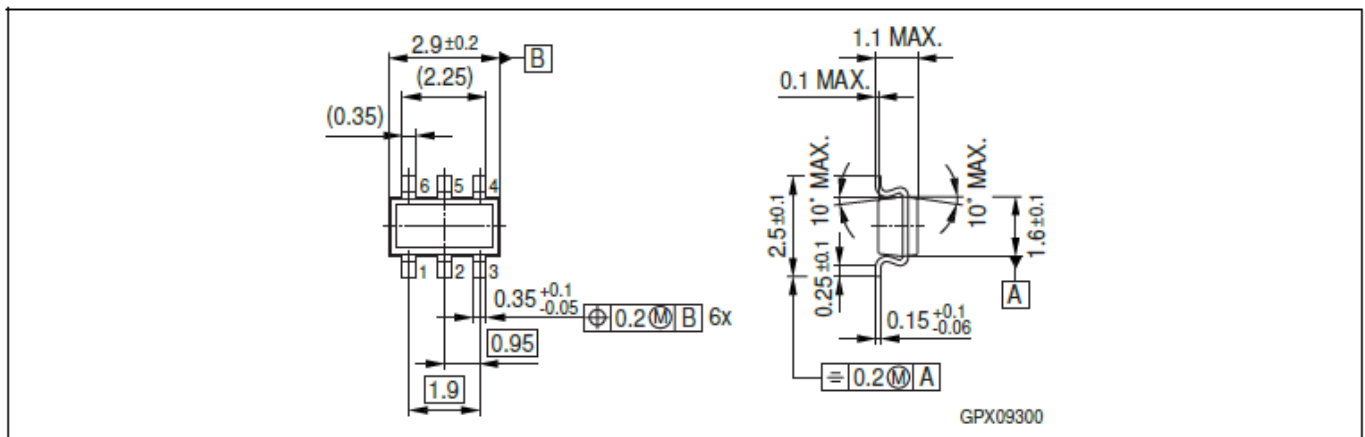

Figure 17 Package Outline TSOP6

[www.infineon.com](http://www.infineon.com)