

OPTIREG™ linear voltage regulator TLS820F3ELVxx demoboard

Z8F68163446



Family
overview



Support

Preface

Scope and purpose

This document describes the usage of the OPTIREG™ linear voltage regulator TLS820F3ELVxx demoboard for the TLS820F3ELV33 and TLS820F3ELV50 from Infineon Technologies AG. Please also refer to the corresponding datasheets.

Intended audience

This document is intended for engineers who develop applications.

Table of contents

	Preface	1
	Table of contents	2
1	Introduction	3
1.1	General description	3
1.2	TLS820F3ELV33 and TLS820F3ELV50 features	3
1.3	Block diagram	4
2	Demoboard	5
2.1	Assembly	5
2.2	Operating conditions	6
2.3	Configuration	7
2.3.1	EN selection	7
2.3.2	RADJ selection	8
2.3.3	Signal adaption	10
3	Schematic and layout	11
3.1	Schematic	11
3.2	Layout	12
4	Bill of materials	16
5	Restrictions	17
6	Revision history	18
	Disclaimer	19

1 Introduction

1 Introduction

1.1 General description

The TLS820F3ELV33 and TLS820F3ELV50 are monolithic integrated low drop out voltage regulators for loads up to 200 mA in a PG-SSOP-14 package. With an input voltage range of 3 V to 42 V and very low quiescent current of only 26 μ A, these devices are perfectly suitable for automotive or other supply systems connected to the battery permanently. Both variants provide an output voltage accuracy of $\pm 2\%$.

The loop concept combines fast regulation and very good stability while requiring only one small ceramic capacitor of 1 μ F at the output. The operating range starts already at an input voltage of only 3 V (extended operating range). This makes the devices also suitable to supply automotive systems that need to operate during cranking condition.

Additional features include:

- switching the device on and off via enable
- reset circuit to supervise the output voltage and delay the reset at power-on with an adjustable lower reset threshold
- watchdog circuit to monitor a microcontroller
- shared external delay capacitor to set both reset timing and watchdog timing
- output current limitation
- thermal shutdown

1.2 TLS820F3ELV33 and TLS820F3ELV50 features

- Output voltage 5 V and 3.3 V $\pm 2\%$
- Current capability 200 mA
- Input voltage range from 3 V to 42 V
- Stable with 1 μ F ceramic output capacitor
- Ultra low current consumption: typically 26 μ A
- Very low drop out voltage: typically 100 mV at 100 mA
- Watchdog circuit for monitoring a microprocessor
- Watchdog inhibit
- Reset circuit supervises the output voltage
 - Programmable undervoltage reset threshold: minimum 2.5 V
 - Programmable delay time
- Separate outputs for reset and watchdog
- Enable
- Output current limitation
- Overtemperature shutdown
- Automotive temperature range $T_j = -40^\circ\text{C}$ to 150°C
- Green Product (RoHS compliant)

1 Introduction

1.3 Block diagram

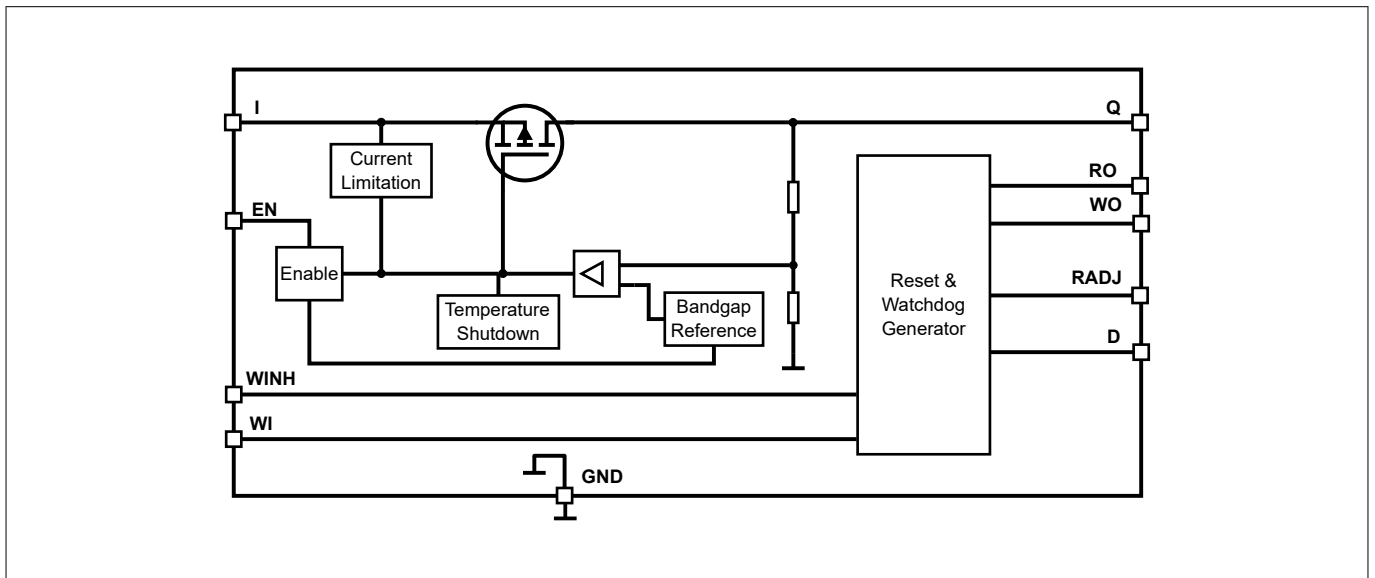

Figure 1 Block diagram TLS820F3ELVxx

2 Demoboard

2 Demoboard

2.1 Assembly

There are two different demoboard assemblies available. One for the TLS820F3ELV33 and one for the TLS820F3ELV50. They differ only by the resistor divider values on the RADJ pin, see [Table 2](#).

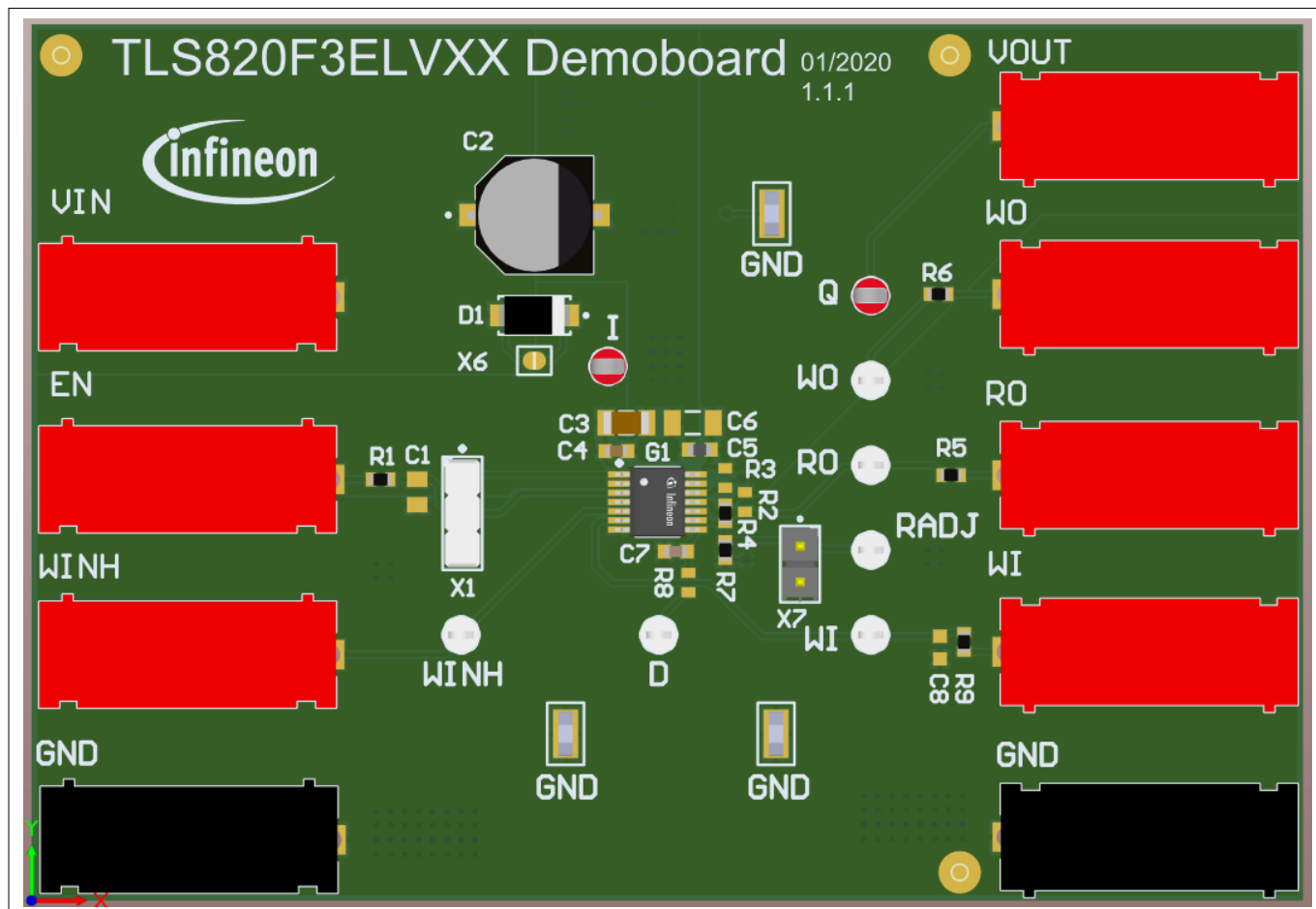

Figure 2 Assembly TLS820F3ELV50

2 Demoboard

2.2 Operating conditions

To avoid electrical damage of the demoboard, the values in [Table 1](#) must be maintained.

Table 1 Limit values for operation¹⁾

Parameter	Symbol ²⁾	Values			Unit	Note or condition
		Min.	Typ.	Max.		
Board supply voltage	V_{IN}	0	–	42	V	–
Output voltage	V_Q	-0.3	–	7	V	³⁾
Output current	I_Q	0	–	200	mA	Limited by overcurrent protection
Enable	V_{EN}	0	–	42	V	
Watchdog inhibit	V_{WINH}	-0.3	–	7	V	³⁾
Watchdog output	V_{WO}	-0.3	–	7	V	³⁾
Watchdog input	V_{WI}	-0.3	–	7	V	³⁾
Reset output	V_{RO}	-0.3	–	7	V	³⁾
Ground voltage	V_{GND}	0	–	0	V	–

- 1) $T_A = 25^\circ\text{C}$.
- 2) Symbols refer to the connectors of the demoboard.
- 3) Absolute maximum rating.

2 Demoboard

2.3 Configuration

The demoboard can be easily configured via jumpers on the board.

The board provides the following configuration options:

- connect the enable signal EN to VIN or to GND with a jumper
- connect the RADJ pin to GND with a jumper to select the default reset thresholds

2.3.1 EN selection

The EN pin can be connected to either GND or to VIN by placing a jumper as shown in [Figure 3](#). The EN pin is always connected to the external banana-plug. If the jumper is placed, then do not connect an external signal to EN.

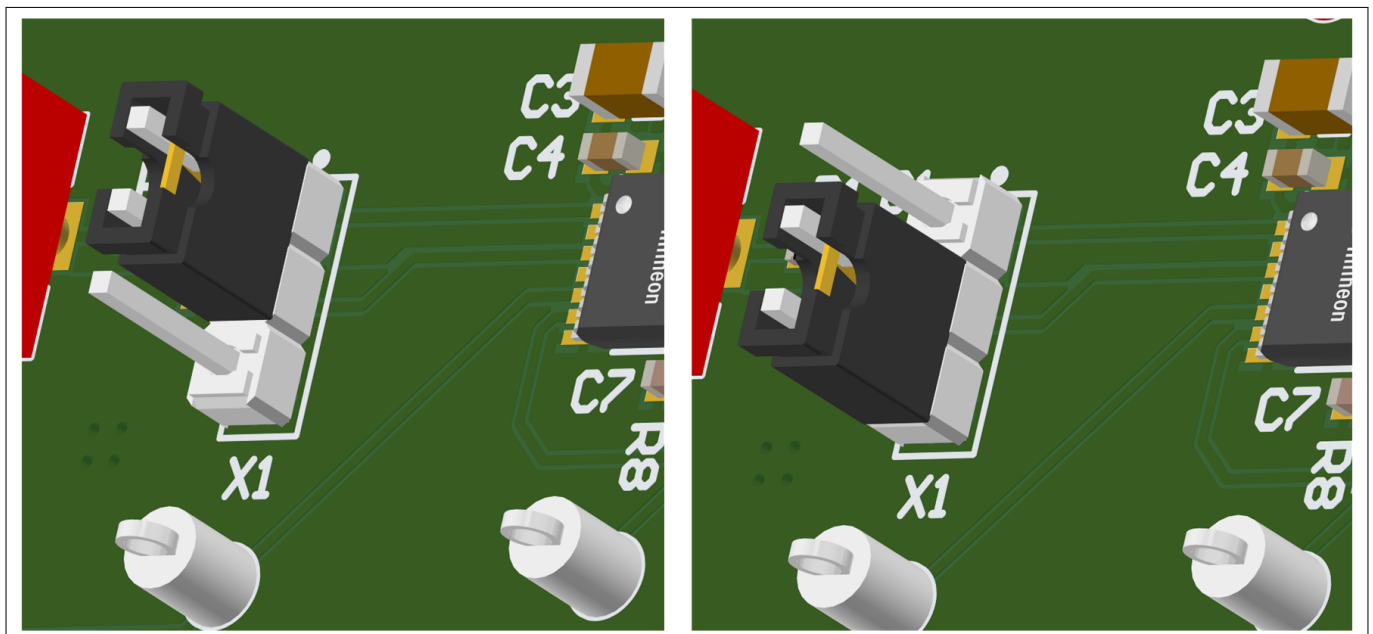

Figure 3 EN jumper (left: EN to VIN; right: EN to GND)

2 Demoboard

2.3.2 RADJ selection

The TLS820F3ELVxx features adjustable reset thresholds. By applying a voltage divider between the Q pin and the RADJ-pin. The demoboard resistors R4 and R7 set the reset adjust threshold, see Figure 4. There are two different assemblies of these resistors, one for the TLS820F3ELV33 and one for the TLS820F3ELV50, see Table 2. Equation 1 gives the formula for calculating the reset threshold. Placing the jumper as shown in Figure 5 connects the RADJ to GND and sets the default reset thresholds as shown in the datasheet. The jumper shorts resistor R7 and causes a small permanent current through R4.

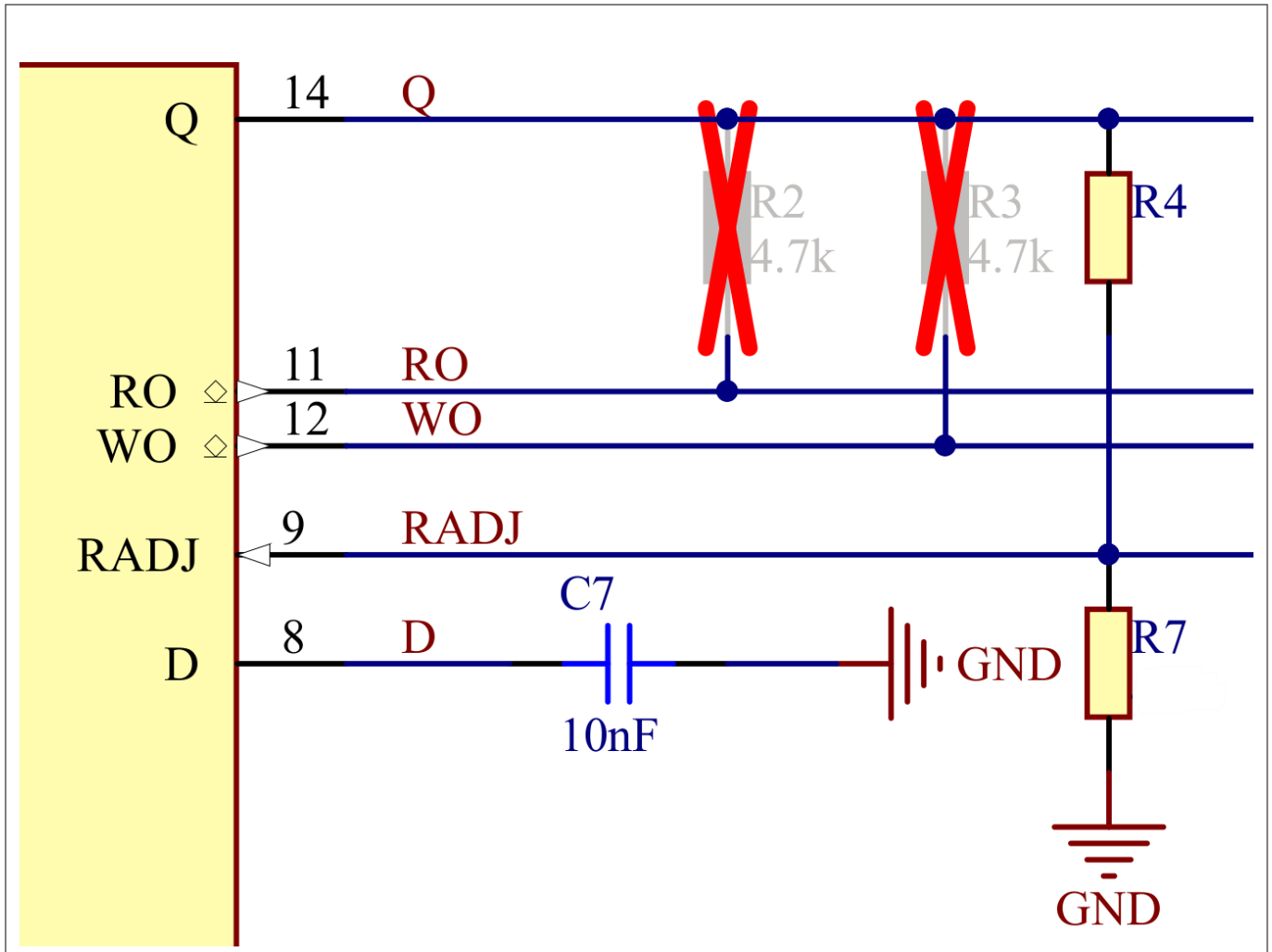

Figure 4 RADJ resistor divider schematic

Table 2 RADJ resistor divider assembly

Variant	R4	R7	V _{RT,lo}
TLS820F3ELV33	9.4 kΩ	4.7 kΩ	2.7 V
TLS820F3ELV50	16.2 kΩ	4.7 kΩ	4 V

$$V_{RT,lo} = V_{RADJ,th} \times \frac{R_4 + R_7}{R_7} \approx 0.9 \times \frac{R_4 + R_7}{R_7}$$

Equation 1 V_{RT,lo} calculation

2 Demoboard

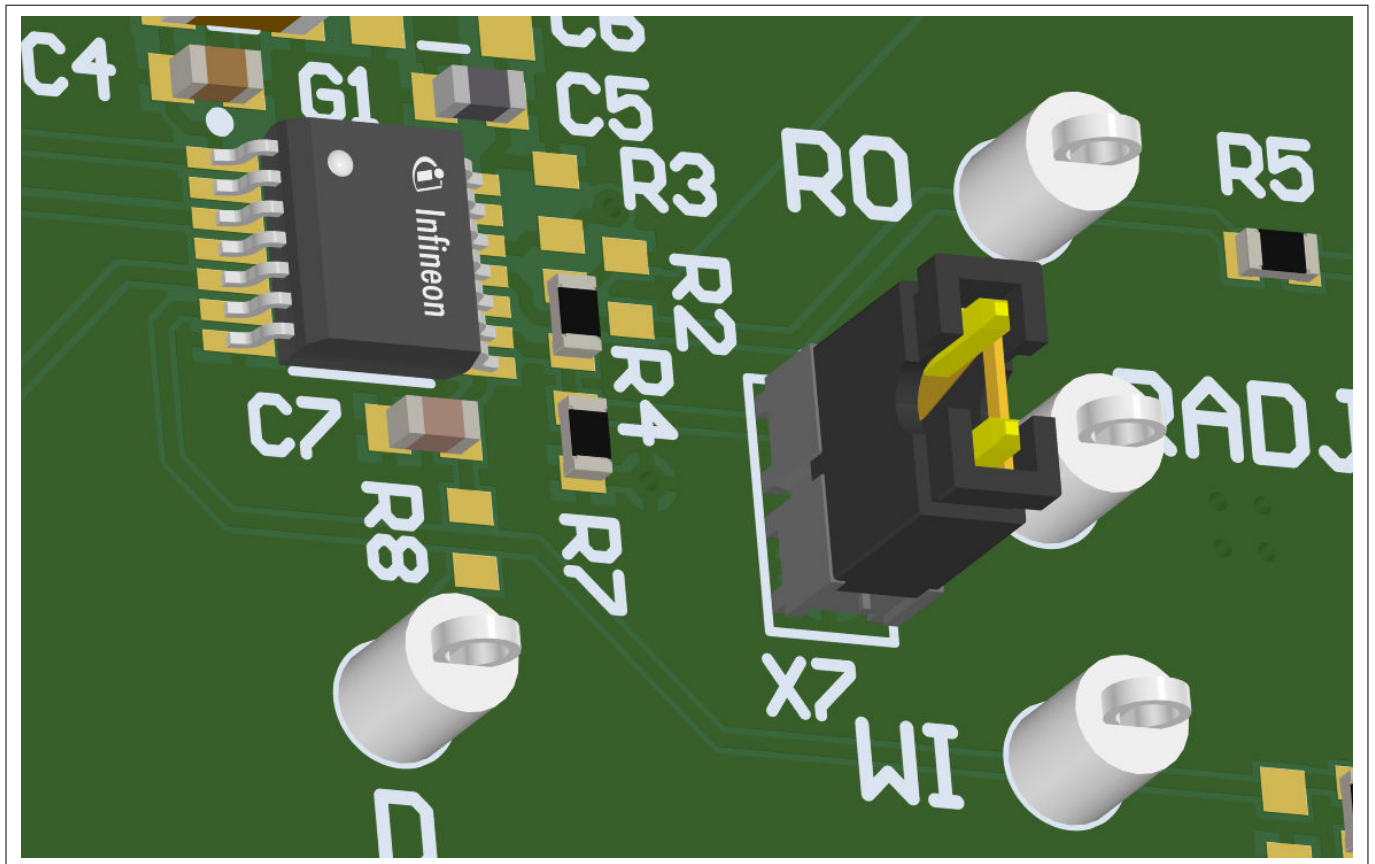

Figure 5 RADJ jumper

2 Demoboard

2.3.3 Signal adaption

For easy signal adaption, for example connecting probes of an oscilloscope, test points are scattered across the PCB. The label of each test point indicates the probed signal. For further information on the mapping between test points and signals see [Figure 7](#). The GND clip of the probe can be attached to one of several ground hooks as shown in [Figure 6](#).

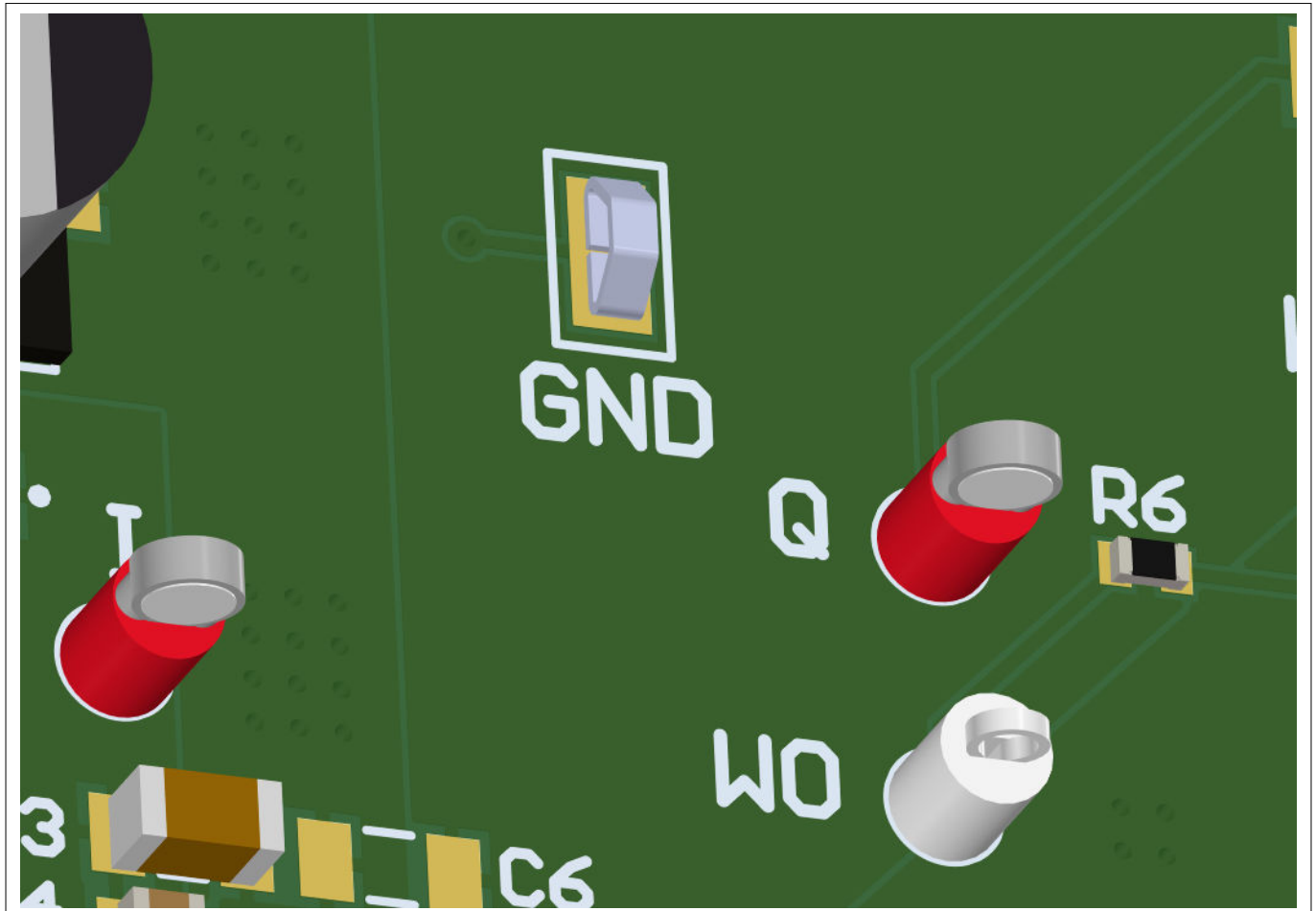

Figure 6 Testpoint and GND hook example

3 Schematic and layout

3 Schematic and layout

3.1 Schematic

The schematic for the TLS820F3ELV50 is assembled with two different configurations for the resistors R4 and R7, depending on whether the TLS820F3ELV33 or TLS820F3ELV50 is mounted, see [Table 2](#) for details. Not mounted parts are optional and marked with a red cross.

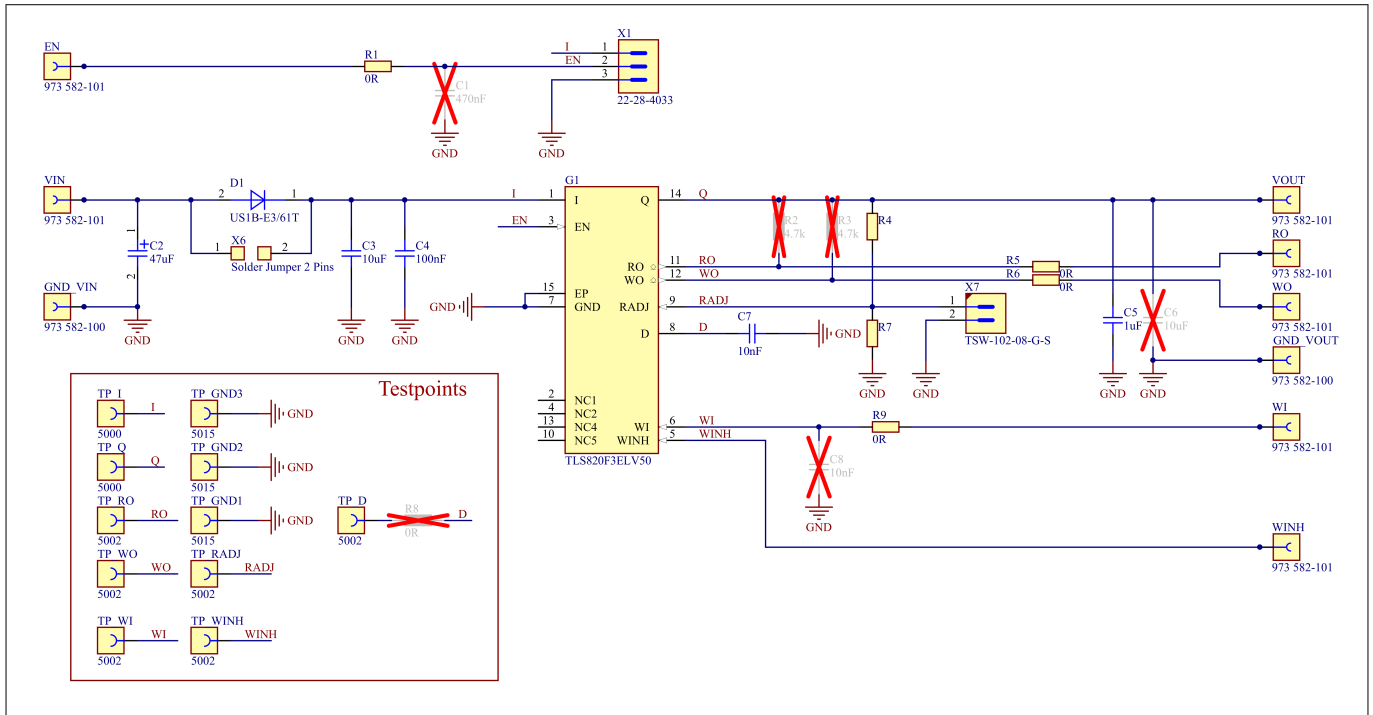

Figure 7 Schematic TLS820F3ELV50

3 Schematic and layout

3.2 Layout

The PCB uses a four layer standard stack-up. The product can also be soldered to double layer boards. However, four layers offer better thermal characteristics. The configuration on this demoboard is comparable to the 2s2p thermal interface situation.

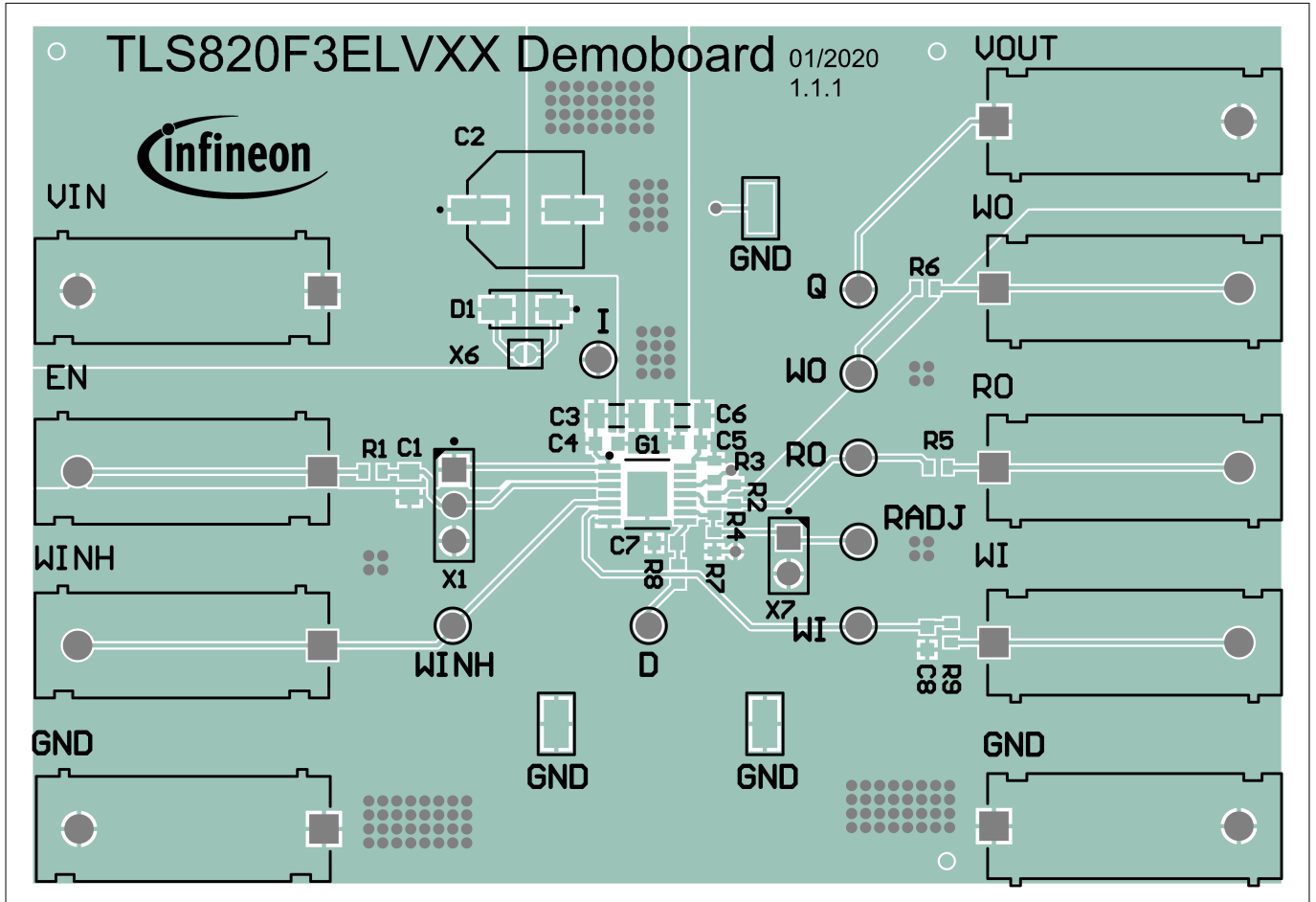

Figure 8 Top layer and components TLS820F3ELV50

3 Schematic and layout

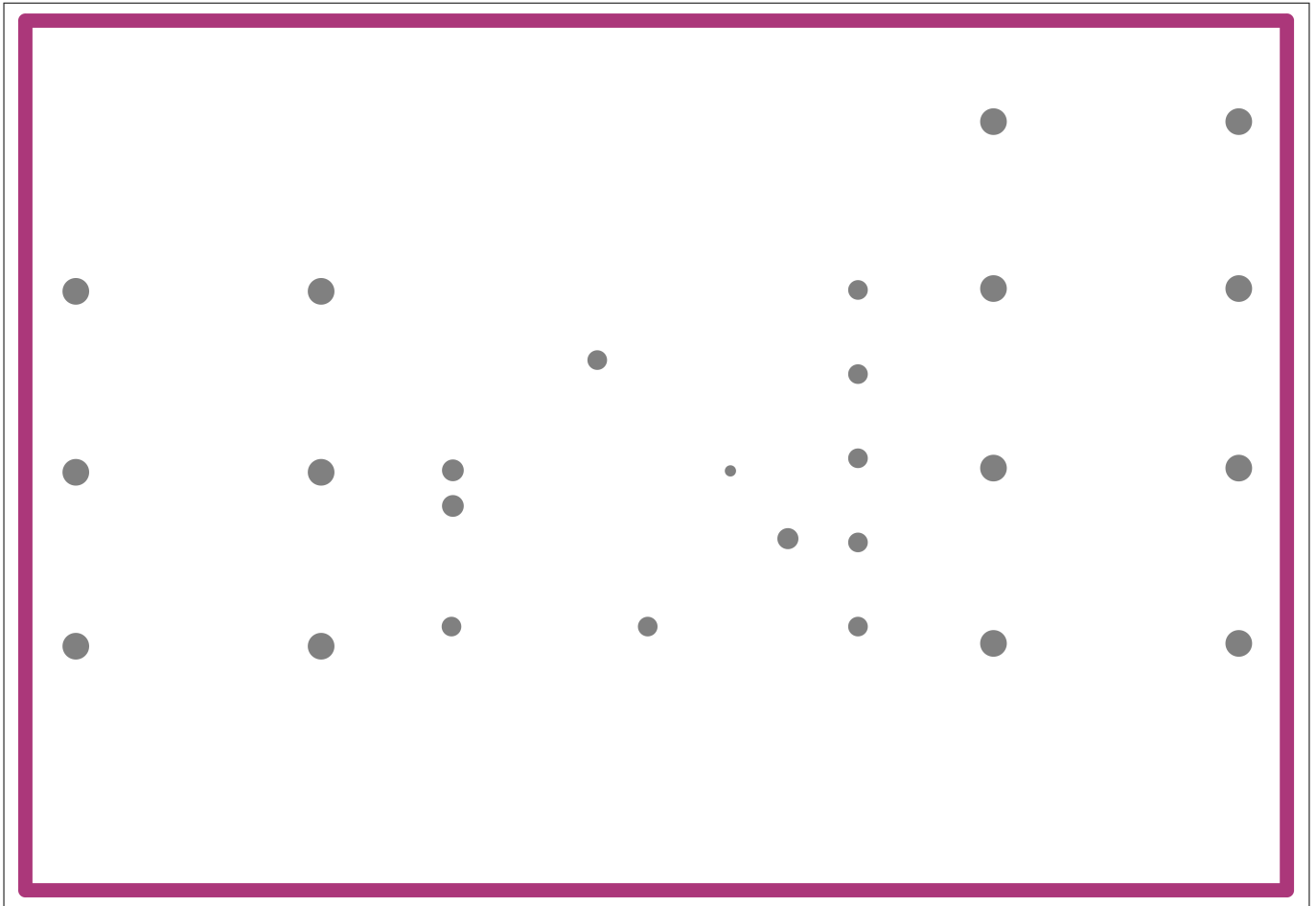

Figure 9 Internal layer 1 TLS820F3ELV50

3 Schematic and layout

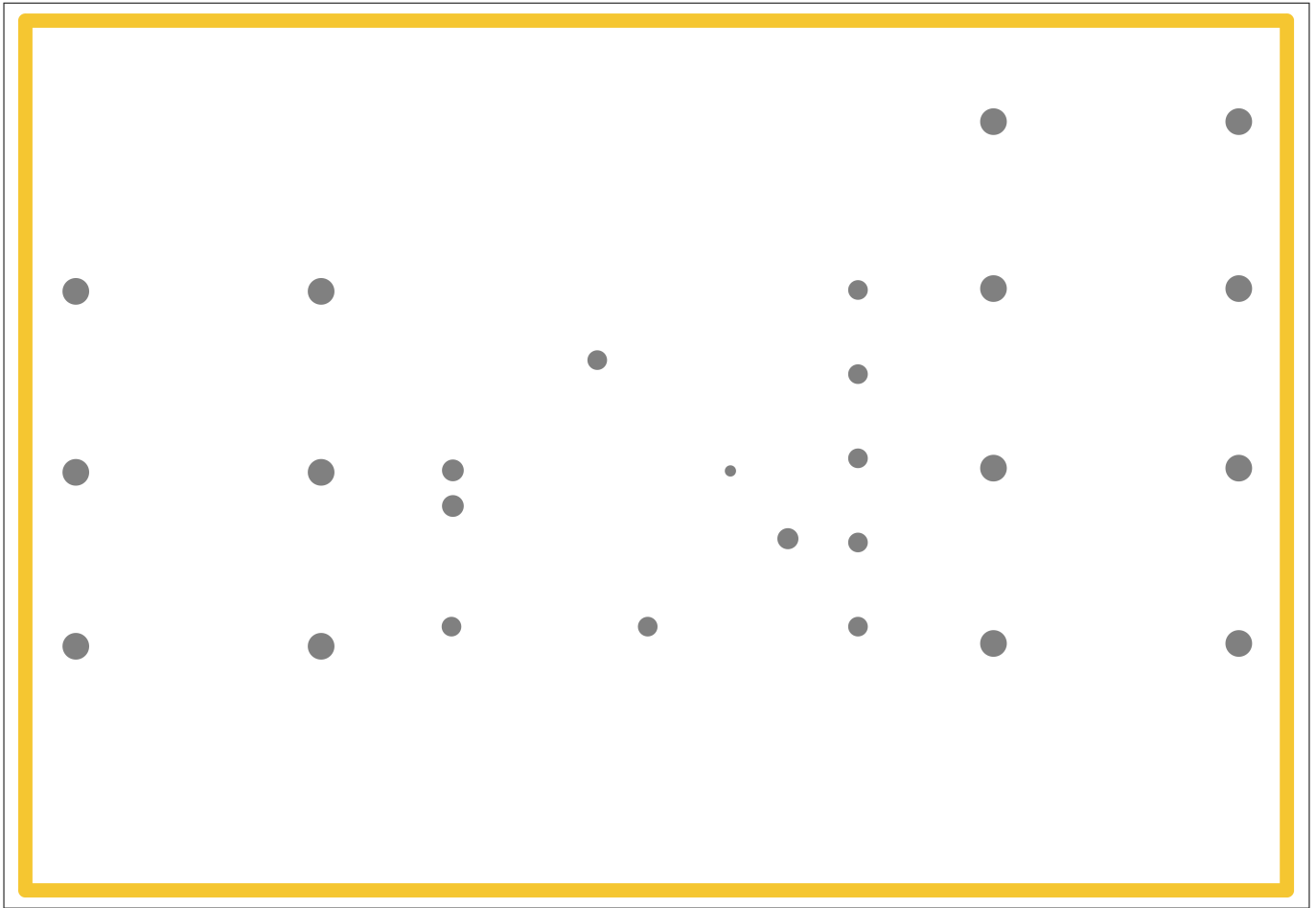

Figure 10 Internal layer 2 TLS820F3ELV50

3 Schematic and layout

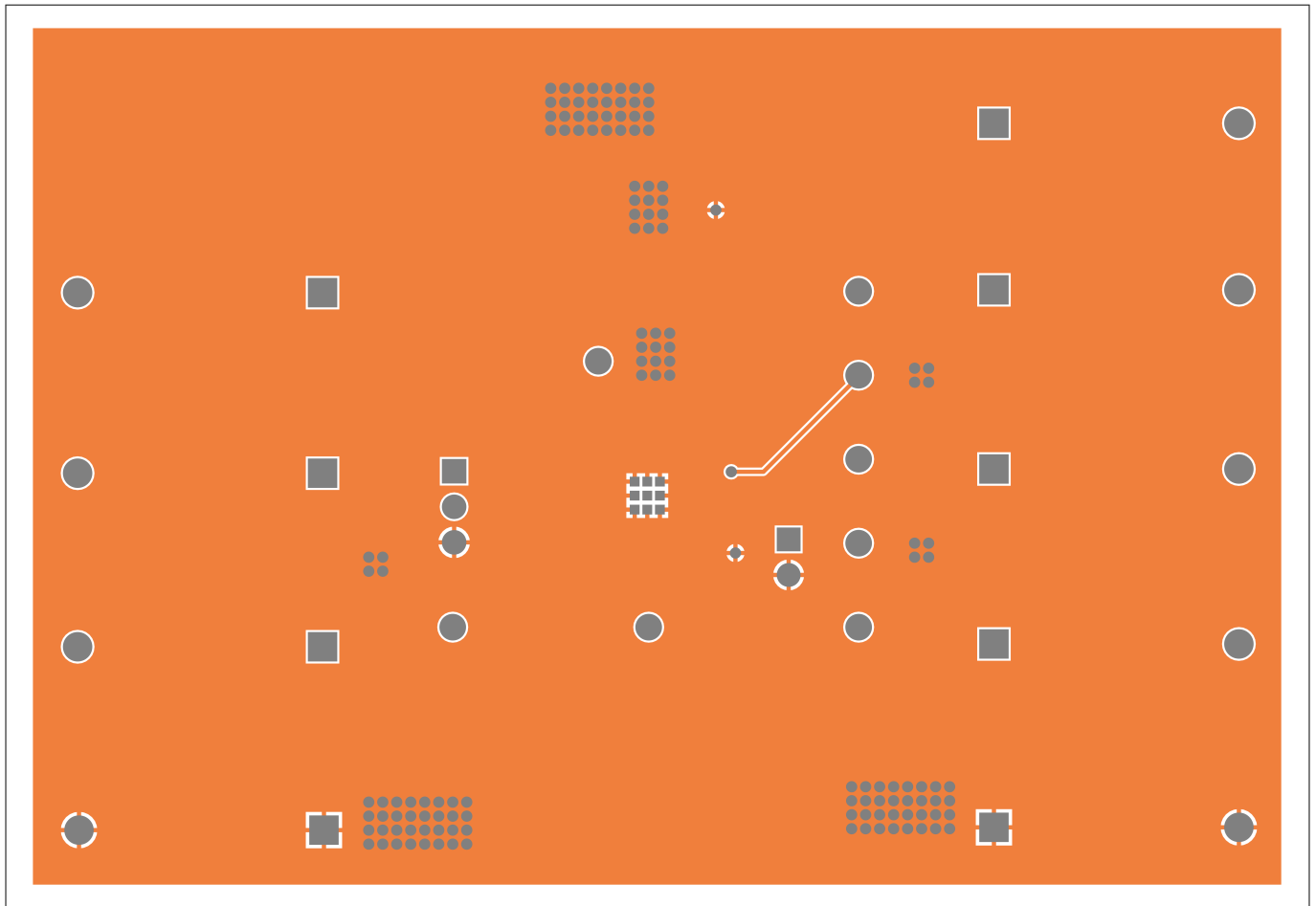

Figure 11 **Bottom layer TLS820F3ELV50**

4 Bill of materials

4 Bill of materials

The bill of materials shows the components on the TLS820F3ELV50. For the mounting condition of each component see [Figure 7](#) and [Figure 8](#). Mechanical parts, such as connectors or test-points are not mentioned. [Table 2](#) shows the configuration for resistors R4 and R7.

Table 3 Bill of materials TLS820F3ELV50

Part	Value	Package
D1	US1B-E3/61T	DO-214
C2	47 μ F / 50 V	n.a.
C3	10 μ F / 50 V	1206
C4	100 nF / 50 V	0603
C5	1 μ F / 16 V	0603
C7	10 nF / 50 V	0603
R1, R5, R6, R9	0 Ω	0603

5 Restrictions

This demoboard offers limited features only for evaluation and testing of Infineon products. The demoboard is not an end product or finished appliance, nor is it intended or authorized by Infineon to be integrated into end products. The demoboard may not be used in any production system.

For further information please visit www.infineon.com.

6 Revision history

6 Revision history

Revision	Date	Changes
1.01	2022-12-01	Document updated • Editorial changes
1.0	2020-02-26	Document created.

Trademarks

All referenced product or service names and trademarks are the property of their respective owners.

Edition 2022-12-01

Published by

Infineon Technologies AG

81726 Munich, Germany

© 2022 Infineon Technologies AG

All Rights Reserved.

Do you have a question about any aspect of this document?

Email: erratum@infineon.com

Document reference

IFX-Z8F68163446

Important notice

The information given in this document shall in no event be regarded as a guarantee of conditions or characteristics ("Beschaffheitsgarantie").

With respect to any examples, hints or any typical values stated herein and/or any information regarding the application of the product, Infineon Technologies hereby disclaims any and all warranties and liabilities of any kind, including without limitation warranties of non-infringement of intellectual property rights of any third party.

In addition, any information given in this document is subject to customer's compliance with its obligations stated in this document and any applicable legal requirements, norms and standards concerning customer's products and any use of the product of Infineon Technologies in customer's applications.

The data contained in this document is exclusively intended for technically trained staff. It is the responsibility of customer's technical departments to evaluate the suitability of the product for the intended application and the completeness of the product information given in this document with respect to such application.

Warnings

Due to technical requirements products may contain dangerous substances. For information on the types in question please contact your nearest Infineon Technologies office.

Except as otherwise explicitly approved by Infineon Technologies in a written document signed by authorized representatives of Infineon Technologies, Infineon Technologies' products may not be used in any applications where a failure of the product or any consequences of the use thereof can reasonably be expected to result in personal injury.