

# Application Note

## TLE7250

### About this document

#### Scope and purpose

This document provides application information for the transceiver TLE7250 from Infineon Technologies AG as Physical Medium Attachment within a Controller Area Network (CAN).

This document contains information about:

- set-ups for CAN application
- mode control
- fail safe behavior
- power supply concepts
- power consumption aspects

This document refers to the data sheet of the Infineon Technologies AG CAN Transceiver TLE7250.

*Note: The following information is given as a hint for the implementation of our devices only and shall not be regarded as a description or warranty of a certain functionality, condition or quality of the device.*

#### Intended audience

This document is intended for engineers who develop applications.

## Table of Contents

	<b>About this document</b> .....	<b>1</b>
	<b>Table of Contents</b> .....	<b>2</b>
<b>1</b>	<b>CAN Application</b> .....	<b>3</b>
<b>2</b>	<b>TLE7250 Description</b> .....	<b>5</b>
2.1	Features .....	5
2.2	Mode Description .....	5
<b>3</b>	<b>In Vehicle Network Applications</b> .....	<b>6</b>
3.1	Clamp 30 and Clamp 15 .....	6
3.2	Baud Rate versus Bus Length .....	7
<b>4</b>	<b>CAN FD</b> .....	<b>8</b>
<b>5</b>	<b>Pin Description</b> .....	<b>9</b>
5.1	$V_{CC}$ Pin .....	9
5.2	NEN and NRM Pins .....	9
5.3	TxD Pin .....	9
5.4	RxD Pin .....	9
5.5	CANH and CANL Pins .....	10
5.6	GND Pin .....	10
<b>6</b>	<b>Transceiver Supply</b> .....	<b>11</b>
6.1	Voltage Regulator .....	11
6.2	External Circuitry .....	11
6.3	$V_{CC}$ (5 V) Power Supply Concept .....	11
6.3.1	Single $V_{CC}$ 5 V power supply .....	11
6.3.2	Dual $V_{CC}$ 5 V power supply .....	12
6.4	Current Consumption .....	12
6.5	Loss of Battery (Unsupplied Transceiver) .....	12
6.6	Loss of Ground .....	12
6.7	Ground Shift .....	13
<b>7</b>	<b>Transceiver Control</b> .....	<b>14</b>
7.1	Mode Change by NEN, NRM .....	14
7.2	Mode Change Delay .....	14
<b>8</b>	<b>Failure Management</b> .....	<b>15</b>
8.1	TxD Dominant Time-out Detection .....	15
8.2	Minimum Baud Rate and Maximum TxD Dominant Phase .....	15
8.3	Short Circuit .....	16
8.4	TLE7250 Junction Temperature .....	17
<b>9</b>	<b>PCB Layout Recommendations for CAN FD</b> .....	<b>18</b>
<b>10</b>	<b>References</b> .....	<b>19</b>
	<b>Terms and Abbreviations</b> .....	<b>19</b>
<b>11</b>	<b>Revision History</b> .....	<b>20</b>

CAN Application

# 1 CAN Application

With the growing number of electronic modules in cars the amount of communication between modules increases. In order to reduce wires between the modules CAN was developed. CAN is a Class-C, multi master serial bus system. All nodes on the bus system are connected via a two wire bus. A termination of  $R_T = 120 \Omega$  or a split termination ( $R_{T/2} = 60 \Omega$  and  $C_T = 4.7 \text{ nF}$ ) on two nodes within the bus system is recommended.

Typically an ECU consists of:

- power supply
- microcontroller with integrated CAN protocol controller
- CAN transceiver

The CAN protocol uses a lossless bit-wise arbitration method of conflict resolution. This requires all CAN nodes to be synchronized. The complexity of the network can range from a point-to-point connection up to hundreds of nodes. A simple network concept using CAN is shown in [Figure 1](#).

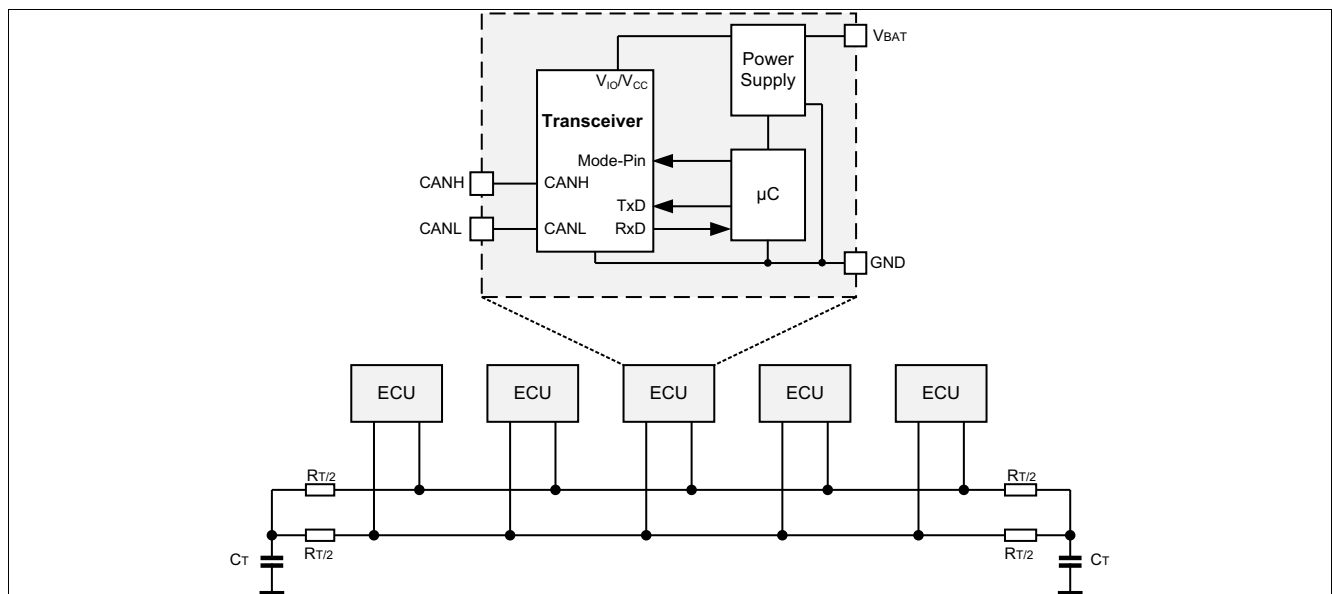

**Figure 1** CAN Example with Typical ECU Using TLE7250

The CAN bus physical layer has two defined states: dominant and recessive. In recessive state CANH and CANL are biased to  $V_{CC}/2$  (typ. 2.5 V) and the differential output voltage  $V_{Diff}$  is below 0.5 V.

A “low” signal applied to Tx/D pin generates a dominant state on CANH and CANL. The voltage on CANH changes towards  $V_{CC}$  and CANL goes towards GND. The differential voltage  $V_{Diff}$  is higher than 0.9 V.

CAN Application

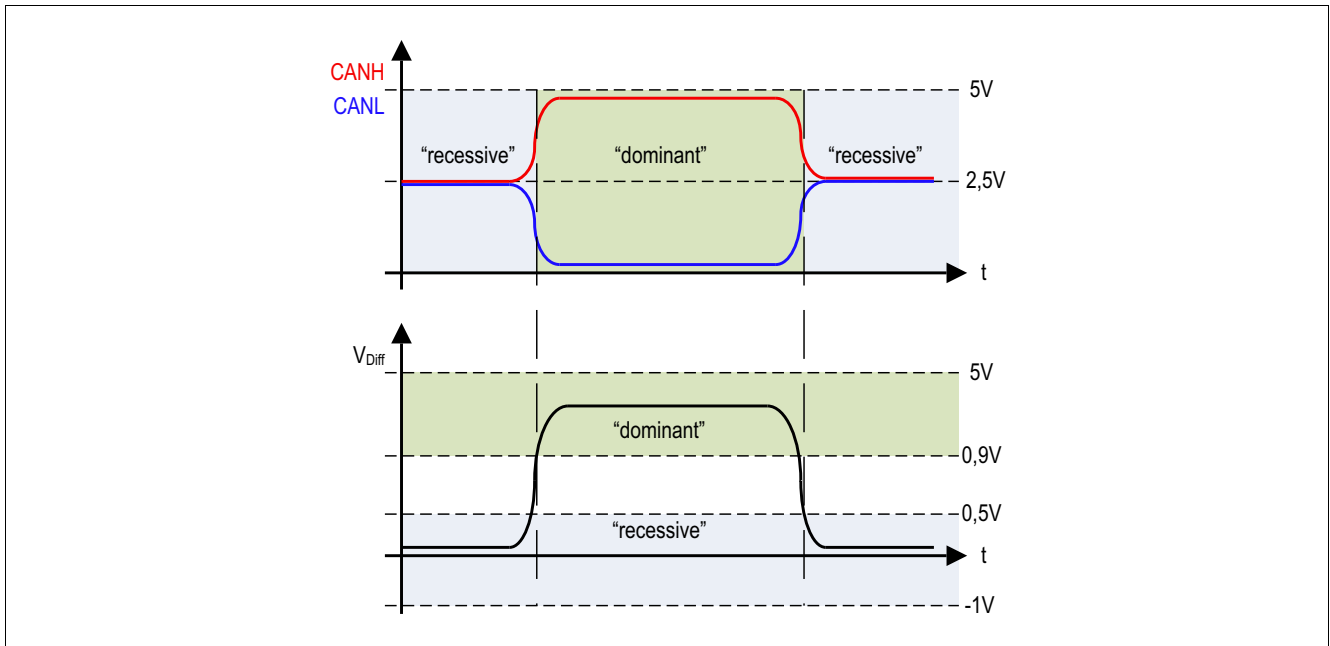

Figure 2 Voltage Levels according to ISO 11898-2

Table 1 Voltage Levels according to ISO 11898-2

Parameter	Symbol	Values			Unit	Note or Test Condition
		Min.	Typ.	Max.		
<b>Recessive State</b>						
Output Bus Voltage	$V_{CANL,H}$	2.0	2.5	3.0	V	No load
Differential Output Bus Voltage	$V_{Diff\_R\_NM}$	-500	-	50	mV	No load
Differential Input Bus Voltage	$V_{Diff\_R\_Range}$	-1.0	-	0.5	V	-
<b>Dominant State</b>						
Output Bus Voltage	$V_{CANH}$	2.75	3.5	4.5	V	$50 \Omega < R_L < 65 \Omega$
	$V_{CANL}$	0.5	1.5	2.25	V	$50 \Omega < R_L < 65 \Omega$
Differential Output Bus Voltage	$V_{Diff\_D\_NM}$	1.5	2.0	3.0	V	$50 \Omega < R_L < 65 \Omega$
Differential Input Voltage	$V_{Diff\_D\_Range}$	0.9	-	5.0	V	-

The CAN physical layer is described in ISO 11898-2. The CAN transceiver TLE7250 fulfills all parameters defined in ISO 11898-2. This document describes CAN applications with the TLE7250. It provides application hints and recommendations for the design of CAN electronic control units (ECUs) using the CAN transceiver TLE7250 from Infineon Technologies AG.

TLE7250 Description

## 2 TLE7250 Description

The transceiver TLE7250 represents the physical medium attachment, interfacing the CAN protocol controller to the CAN transmission medium. The transmit data stream of the protocol controller at the TxD input is converted by the CAN transceiver into a bus signal. The receiver of the TLE7250 detects the data stream on the CAN bus and transmits it via the RxD pin to the protocol controller.

### 2.1 Features

The main features of the TLE7250 are:

- Baud rate up to 2 Mbit/s
- Very low Electromagnetic Emission (EME) and high Electromagnetic Immunity (EMI)
- Excellent ESD performance according to HBM (+/-9 kV) and IEC (+/-8 kV)
- Very low current consumption in Power-save mode
- Transmit data (TxD) dominant time-out function
- Supply voltage range 4.5 V to 5.5 V
- Thermal shutdown protection

### 2.2 Mode Description

The TLE7250 supports three different modes of operation. The mode of operation depends on the status of the mode selection pin NEN, NRM,;

- Normal-operating mode: Used for communication on the HS CAN bus. Transmit and receive data on the bus.
- Receive-only mode: Allows diagnostics (to avoid the acknowledge bit (ACK) implemented by software), to check modules connections or to avoid communication errors on the bus due to microcontroller failure. Blocking babbling idiots from disturbing communication. Used for Pretended Networking to set ECU and microcontroller to low-power mode, waiting for a specific message to switch to Normal-operating mode. Pretended Networking is used to reduce current consumption of ECUs.
- Power-save mode: Reduces current consumption in afterrun when there is no communication on the HS CAN bus with ECU still active. Emergency undervoltage state, when the microcontroller detects undervoltage and starts saving internal information. In order to reduce current consumption the transceiver is set to Power-save mode.

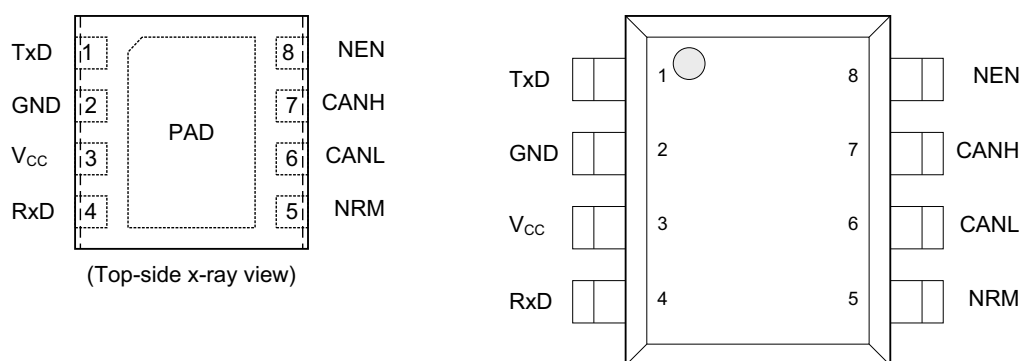

Figure 3 Pin Configuration of the TLE7250

### 3 In Vehicle Network Applications

The TLE7250/51-Family offers a perfect match for various ECU requirements. For partially supplied ECUs (Clamp 15) the TLE7250 is suitable. According to the requirements of automobile manufacturers, the modules can either be permanently supplied or unsupplied during the car is parked. The main reason for unsupplied modules is saving battery energy. Permanently supplied modules can wake up quickly via CAN message.

#### 3.1 Clamp 30 and Clamp 15

Clamp 30:

Permanently supplied modules, even when the car is parked are required by body applications such as door modules, RF keyless entry receivers, etc. Modules are directly connected to the battery. This supply line is called clamp 30. As battery voltage is present permanently, the voltage regulator, transceiver and microcontroller are always supplied. Therefore voltage regulator, transceiver and microcontroller need to be set to low-power mode in order to reduce current consumption to a minimum.

Clamp 15:

Partially supplied modules are typically used in under hood applications such as ECUs. When the car is parked a main switch or ignition key switches off the battery supply. This supply line is called clamp 15. When the battery voltage is not present, the voltage regulator and transceiver are switched off.

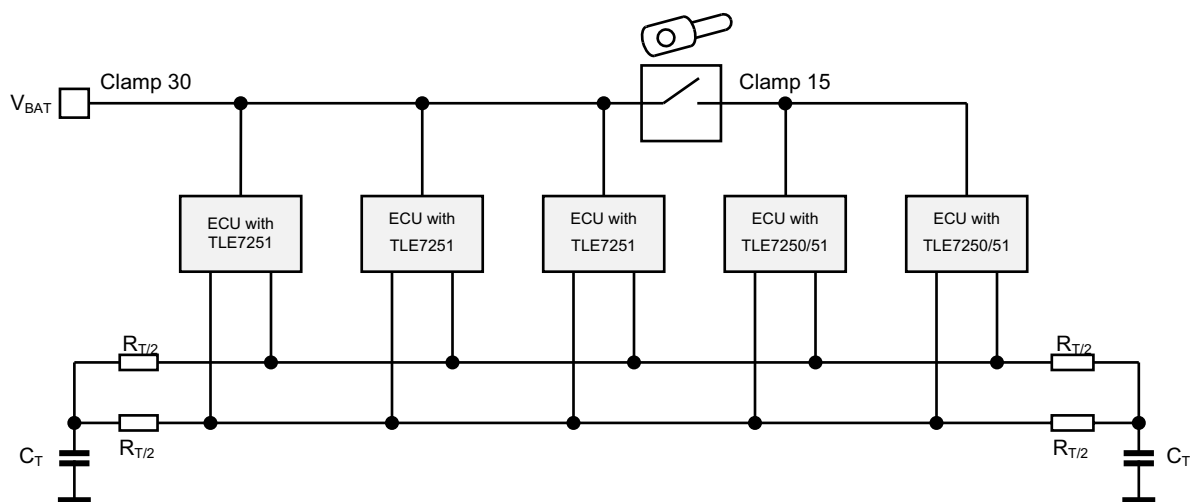

Figure 4 CAN with ECUs Using TLE7250

In Clamp 15 applications there is no need to use transceivers with bus wake-up feature. Therefore TLE7250 offers three different modes, that make applications more flexible (see [Chapter 2.2](#)). For applications that do not use the bus wake-up feature, the TLE7250 offers the Power-save mode with very low current consumption. There is also the possibility to reduce the current consumption of the ECU more by disconnecting the TLE7250 from the power supply. If communication is still on the HS CAN bus, then the TLE7250 has a perfect passive bus behavior in order not to affect CAN bus communication, while the TLE7250 is switched off.

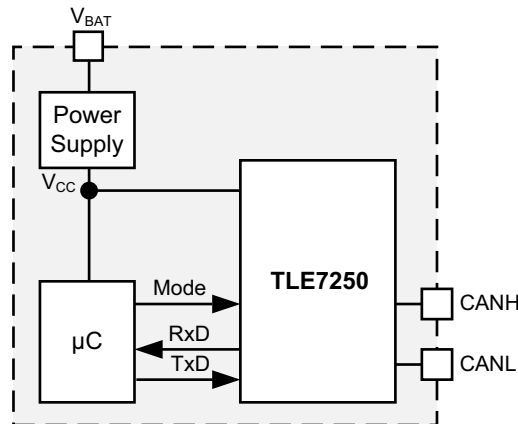

Figure 5 Example ECU with TLE7250

### 3.2 Baud Rate versus Bus Length

Table 2 Recommended Baud Rate versus Bus Length

Baud Rate (kbit/s)	Bus Length (m) Maximum Distance between two Nodes
1000	10
500	40
250	120
125	500
50	1000

Baud rate is limited by:

- bus length
- ringing
- propagation delay of cables
- propagation delay of the CAN controller of the transceiver

The two most distant nodes (A and B) in a CAN network are the limiting factor in transmission speed. The propagation delays must be considered because a round trip has to be made from the two most distant CAN controllers on the bus.

Worst case scenario: When node A starts transmitting a dominant signal, it takes a certain period of time ( $t = t_{\text{CANcontroller}} + t_{\text{Transceiver}} + t_{\text{Cable}}$ ) until the signal arrives at node B.

The propagation delay is estimated by: CAN controller delay, transceiver delay, bus length delay. Assumption: 70 ns for CAN controller, 255 ns for transceiver, 5 ns per meter of cable. Example with 50 m cable length:

$$t_{\text{prop}} = t_{\text{CANcontroller}} + t_{\text{Transceiver}} + t_{\text{Cable}} + t_{\text{CANcontroller}} + t_{\text{Transceiver}} + t_{\text{Cable}} = 70 \text{ ns} + 255 \text{ ns} + 50 \text{ m} \times 5 \text{ ns/m} + 70 \text{ ns} + 255 \text{ ns} + 50 \text{ m} \times 5 \text{ ns/m} = 1150 \text{ ns}$$

Some other factors of great influence on the maximum baud rate are cable capacitance, oscillator tolerance, ringing and reflection effects depending on the network topology. In addition to theoretical maximum propagation delay all other effects must be taken into account and an additional margin of safety must be added. Wire resistance increases with bus length and therefore the bus signal amplitude may be degraded.

CAN FD

## 4 CAN FD

CAN FD (Flexible Data Rate) is the advanced version of classical CAN. Classical CAN is specified by ISO 11898-2 for data transmission rate up to 1 Mbit/s. For CAN FD with higher data transmission rate (2 Mbit/s) ISO 11898-2 specifies additional timing parameters. CAN FD uses the same physical layer as classical CAN does, but allows higher data transmission rate and increased payload per message. During the arbitration phase and checksum the data transmission rate is the same as for classical CAN (1 Mbit/s). As soon as one node in the CAN FD network starts transmitting the payload, the data rate increases (2 Mbit/s). The increase in baud rate is possible as only one node transmits during the data transmission phase. All other nodes listen to the data on the CAN bus. Instead of 8 bytes per message (classical CAN) payload is increased up to maximum 64 byte per message. Using CAN FD saves transmission time and allows increased data payload. In order to ensure reliable data transmission, CAN FD requires a CAN transceiver with full ISO 11898-2 specification for Flexible Data rate up to 2 Mbit/s.

The TLE7250 from Infineon Technologies AG is the perfect match for CAN FD networks. TLE7250 fulfills or exceeds all classical CAN and CAN FD parameters of ISO 11898-2 in order to enable smooth and safe usage within applications.

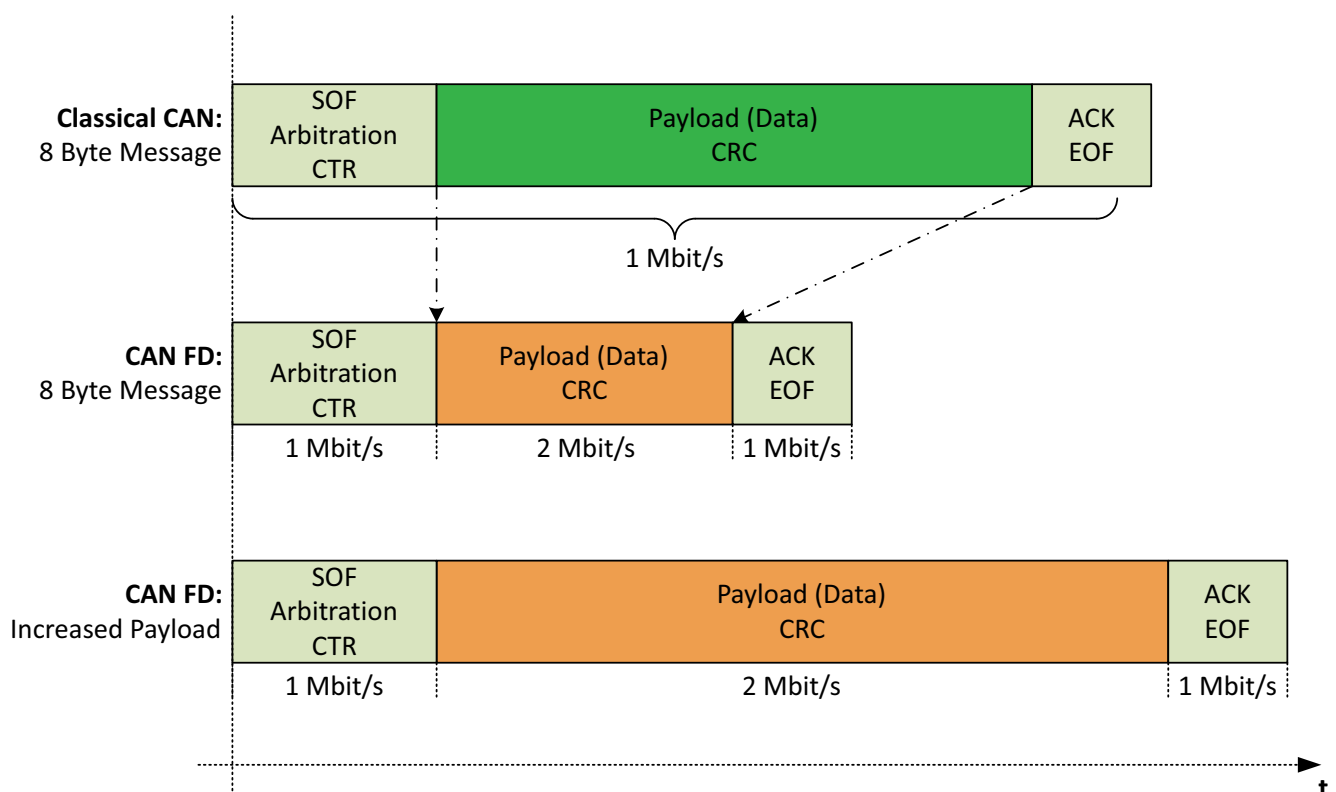

Figure 6 Classical CAN Data Rate and CAN FD Data Rate



Pin Description

## 5 Pin Description

### 5.1 $V_{CC}$ Pin

The  $V_{CC}$  pin supplies the transmitter output stage. The transmitter operates according to data sheet specifications in the voltage range of  $4.5\text{ V} < V_{CC} < 5.5\text{ V}$ . Voltage  $V_{CC} > 6\text{ V}$  can damage the device. If  $V_{CC} < V_{CC\_UV}$ , then the transmitter is disabled. The undervoltage threshold  $V_{CC\_UV}$  is in the range from 3.65 V to 4.3 V. If  $V_{CC\_UV} < V_{CC} < 4.5\text{ V}$ , then the transmitter is enabled and can then send data to the bus, but parameters may be outside the specified range.

### 5.2 NEN and NRM Pins

The NEN pin and the NRM set the mode of TLE7250 and are usually directly connected to output ports of a microcontroller. If the mode pins are unconnected and TLE7250 is supplied by  $V_{CC}$ , then the device enters Power-save mode, due to the internal pull-up resistor to  $V_{CC}$  on NEN and NRM. [Table 3](#) shows mode changes via the NEN and NRM pins, assuming  $V_{IO} > V_{IO\_UV}$ . Features and modes of operation are described in [Chapter 2](#).

**Table 3 Mode Selection via NEN and NRM**

Mode of Operation	NEN	NRM	Comment
Power-Save mode	“high”	“X”	If NEN is set to “high”, then the device enters Power-save mode, independent of the logical input at NRM.
	“high”		
Receive-Only mode	“low”	“low”	Transmitter is disabled. The receiver is enabled and operates as specified in the data sheet.
Normal-Operating mode	“low”	“high”	If $V_{CC} > V_{CC\_UV}$ , then the transmitter is enabled.

Power-save mode is the low-power mode of TLE7250. In Power-save mode both the transmitter and the receiver are disabled and current consumption is reduced to a minimum. The user can deactivate the transmitter of TLE7250 either by setting the NEN pin to “high” or setting the NRM pin to “low”. This can be used to implement two different fail safe paths.

For disconnected mode pins or microcontroller ports in “tristate” the TLE7250 has an integrated pull-up resistor to  $V_{CC}$ , by default the device is in Power-save mode in order to enable low current consumption.

### 5.3 TxD Pin

TxD is an input pin. TxD pin is used to receive the data stream from the microcontroller. If  $V_{IO} > V_{IO\_UV}$ , then the data stream is transmitted to the HS CAN bus. A “low” signal causes a dominant state on the bus and a “high” signal causes a recessive state on the bus. The TxD input pin has an integrated pull-up resistor to  $V_{CC}$ . If TxD is permanently “low”, for example due to a short circuit to GND, then the TxD time-out feature will block the signal on the TxD input pin (see [Chapter 8.1](#)). It is not recommended to use a series resistor within the TxD line between transceiver and microcontroller. A series resistor may add delay, which degrades the performance of the transceiver, especially in high data rate applications. The data stream sent from the microcontroller to the TxD pin of the transceiver is only transmitted to the HS CAN bus in Normal-operating mode. In all other modes the TxD input pin is blocked.

### 5.4 RxD Pin

RxD is an output pin. The data stream received from the HS CAN bus is displayed on the RxD output pin in Normal-operating mode, Receive-only mode. It is not recommended to use a series resistor within the RxD

---

## Pin Description

line between transceiver and microcontroller. A series resistor may add delay, which degrades the performance of the transceiver, especially in high data rate applications.

### 5.5 CANH and CANL Pins

CANH and CANL are the CAN bus input and output pins. The TLE7250 is connected to the bus via pin CANH and CANL. Transmitter output stage and receiver are connected to CANH and CANL. Data on the TxD pin is transmitted to CANH and CANL and is simultaneously received by the receiver input and signalled on the RxD output pin. For achieving optimum EME (Electromagnetic Emission) performance, transitions from dominant to recessive and from recessive to dominant are done as smooth as possible also at high data rate. Output levels of CANH and CANL in recessive and dominant state are described in [Table 1](#). Due to the excellent ESD performance on CANH and CANL no external ESD components are necessary to fulfill OEM requirements.

### 5.6 GND Pin

The GND pin must be connected as close as possible to module ground in order to reduce ground shift. It is not recommended to place filter elements or an additional resistor between GND pin and module ground. GND must be the same for transceiver, microcontroller and HS CAN bus system.

## 6 Transceiver Supply

The internal logic of TLE7250 is supplied by the  $V_{CC}$  pin. The  $V_{CC}$  pin 5 V supply is used to create the CANH and CANL signal. The transmitter output stage as well as the main CAN bus receiver are supplied by the  $V_{CC}$  pin. This chapter describes aspects of power consumption and voltage supply concepts of TLE7250.

### 6.1 Voltage Regulator

It is recommended to use one of the following Infineon low drop output (LDO) voltage regulators, depending on the  $V_{IO}$  power supply concept:

- 5 V  $V_{CC}$  power supply: TLS850D0TAV50 (500mA), [TLS850F0TA V50](#) (500mA), [TLS810D1EJV50](#) (100mA), [TLS810B1LDV50](#) (100mA), [TLE4266-2](#) (150mA)
- Dual 5V voltage power supply: [TLE4473GV55](#)

Please refer to [Infineon Linear Voltage Regulators](#) for the Infineon voltage regulator portfolio, data sheets and application notes.

### 6.2 External Circuitry

In order to reduce EME and to improve the stability of input voltage level on  $V_{CC}$  of the transceiver, it is recommended to place capacitors on the PCB. During sending a dominant bit to the HS CAN bus, current consumption of TLE7250 is higher than during sending a recessive bit. Data transmission can change the load profile on  $V_{CC}$ . Changes in load profile may reduce the stability of  $V_{CC}$ . If several CAN transceivers are connected in parallel, and if these CAN transceivers are supplied by the same  $V_{CC}$  power supply (for example LDO), then the impact on the stability of  $V_{CC}$  is even stronger. It is recommended to place a 100 nF capacitor as close as possible to  $V_{CC}$  pin. The output of the  $V_{CC}$  power supply (for example LDO) must be stabilized by a capacitor in the range of 1 to 50  $\mu$ F, depending on the load profile. Ceramic capacitors are recommended for low ESR.

### 6.3 $V_{CC}$ (5 V) Power Supply Concept

TLE7250 offers a  $V_{CC}$  input pin that supplies the internal logic and the transmitter output stage.  $V_{CC}$  must be connected to a 5 V voltage regulator. Also the microcontroller must be supplied with 5 V in order to adapt the digital and output levels of the microcontroller to the transceiver. A single voltage regulator can supply both the transceiver and the microcontroller.

#### 6.3.1 Single $V_{CC}$ 5 V power supply

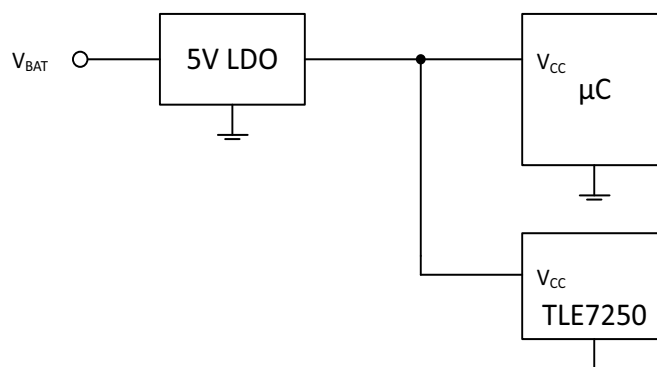

Figure 7 Single  $V_{CC}$  (5 V) Power Supply

### 6.3.2 Dual $V_{CC}$ 5 V power supply

It is possible to use two separate 5 V voltage regulators. If other components are connected to the 5 V voltage regulator that cause noise and transients on the  $V_{CC}$  voltage output of the voltage regulator, then two separate 5 V voltage regulators are useful. Transients disturb the HS CAN Signal and may also increase EME. In order to avoid this coupling the user can separate the power supplies of microcontroller and transceiver by placing two 5 V voltage regulators like [TLE7250](#) or a dual 5 V voltage regulator like [TLE4473GV55](#).

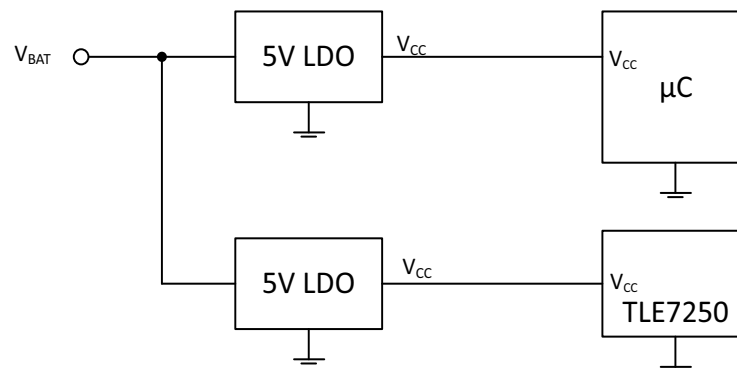

Figure 8 Dual  $V_{CC}$  (5 V) Power Supply

## 6.4 Current Consumption

Current consumption depends on the mode of operation:

- Normal-operating mode:  
Maximum current consumption of TLE7250 on the  $V_{CC}$  supply is specified as 60 mA in dominant state and 5 mA in recessive state. To estimate theoretical current consumption in Normal-operating mode, a duty cycle of 50% can be assumed, with fully loaded bus communication of 50% dominant and 50% recessive. In Normal-operating mode the TLE7250 consumes in worst case maximum:  
$$I_{CC\_AVG} = (I_{CC\_REC} + I_{CC\_DOM}) / 2 = 32.5 \text{ mA}$$
Typically the current consumption is less than 15 mA.
- Receive-only mode :  
In Receive-only mode the TLE7250 has a worst case maximum current consumption of  $I_{ROM} = 3\text{mA}$ . Typically the current consumption is less than 3mA.
- Power-save mode and Forced-power-save mode:  
In Power-save mode most of the functions are turned off.  $V_{CC}$  can be switched off. The maximum current consumption is specified as 12  $\mu\text{A}$ .

## 6.5 Loss of Battery (Unsupplied Transceiver)

When TLE7250 is unsupplied, CANH and CANL act as high impedance. The leakage current  $I_{CANH,IK}$ ,  $I_{CANL,IK}$  at CANH pin or CANL pin is limited to +/- 5  $\mu\text{A}$  in worst case. When unsupplied, TLE7250 behaves like a 1 M $\Omega$  resistor towards the bus. Therefore the device perfectly fits applications that use both Clamp 15 and Clamp 30.

## 6.6 Loss of Ground

If loss of ground occurs, then the transceiver is unsupplied and behaves like in unpowered state.

In applications with inductive load connected to the same GND, for example a motor, the transceiver can be damaged due to loss of ground. Excessive current can flow through the CAN transceiver when the inductor demagnetizes after loss of ground. The ESD structure of the transceiver cannot withstand that kind of Electrical Overstress (EOS). In order to protect the transceiver and other components of the module, an inductive load must be equipped with a free wheeling diode.

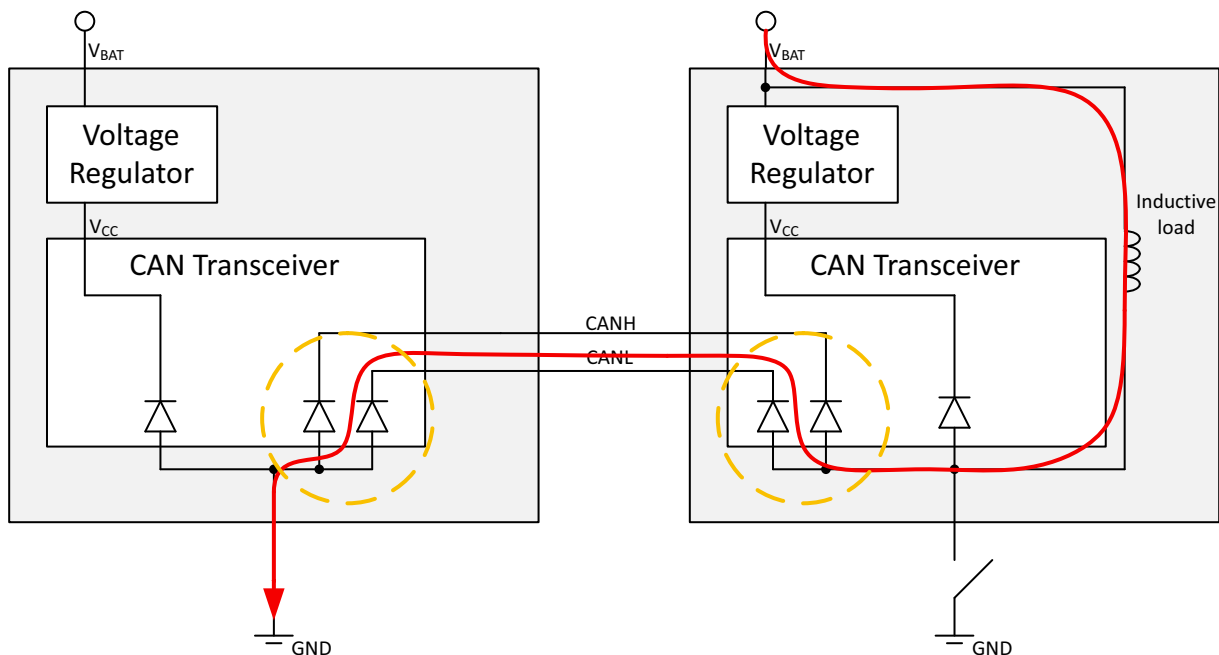

Figure 9 Loss of GND with Inductive Load

## 6.7 Ground Shift

Due to ground shift the GND levels of CAN transceivers within a network may vary. Ground shift occurs in high current applications or in modules with long GND wires. The receiver input stage acts like a resistor ( $R_i$ ) to GND. Because the transmitting node has its GND shifted to  $V_{\text{Shift}}$ , the recessive voltage level  $V_{\text{rec}}$  from the chassis ground is no longer 2.5 V but  $V_{\text{rec}} + V_{\text{Shift}}$ . The same ground shift voltage  $V_{\text{Shift}}$  must be taken into account for the dominant signal. Because CAN uses a differential signal and because of the wide common mode range of +/- 12 V for Infineon transceivers, any CANH and CANL DC value within absolute maximum ratings works.

The recessive CAN bus level  $V_{\text{rec}}$  during a ground shifted node transmitting is equal to the average recessive voltage level of all transceivers:

$$V_{\text{rec}} = [(V_{\text{rec}_1} + V_{\text{Shift}_1}) + (V_{\text{rec}_2} + V_{\text{Shift}_2}) + (V_{\text{rec}_3} + V_{\text{Shift}_3}) + \dots + (V_{\text{rec}_n} + V_{\text{Shift}_n})] / n$$

$n$ : number of connected CAN nodes

$V_{\text{rec}_1}, V_{\text{rec}_2}, \dots, V_{\text{rec}_n}$ : specific recessive voltage level of the transceiver at nodes 1, 2, ..  $n$

$V_{\text{Shift}_1}, V_{\text{Shift}_2}, \dots, V_{\text{Shift}_n}$ : specific ground shift voltage level of the transceiver at nodes 1, 2, ..  $n$

The supply current of a ground shifted transceiver increases by  $I_{\text{CC\_Shift}} = V_{\text{Shift}} / (R_{i_n} / n)$ , assuming all input resistances at CANH and CANL of the transceivers are identical.

## 7 Transceiver Control

The modes of the TLE7250 are controlled by the pins NEN, NRM.

### 7.1 Mode Change by NEN, NRM

The mode of operation is set by the mode selection pins NEN, NRM. By default the NRM input pin and the NEN input pin are “high” due to the internal pull-up resistor to  $V_{CC}$ .

The TLE7250 is in Power-save mode independent of the status of NRM. In order to change the mode to Receive-only mode, NEN and NRM must be switched to “low”. In order to change the mode to Normal-operating mode, NEN must be switched to “low” and NRM must be “high”.

### 7.2 Mode Change Delay

The HS CAN transceiver TLE7250 changes the mode of operation within the transition time period  $t_{Mode}$ . The transition time period  $t_{Mode}$  must be considered in developing software for the application. After the mode change from Power-save mode to a non-low power mode the receiver and/or transmitter is enabled. During the period  $t_{Mode}$  the RxD output pin is permanently set to “high” and does not reflect the status on the CANH and CANL input pins. In addition, during  $t_{Mode}$ , the TxD path is blocked as well. When the mode change is completed, the TLE7250 releases the RxD output pin. **Figure 10** shows this scenario.

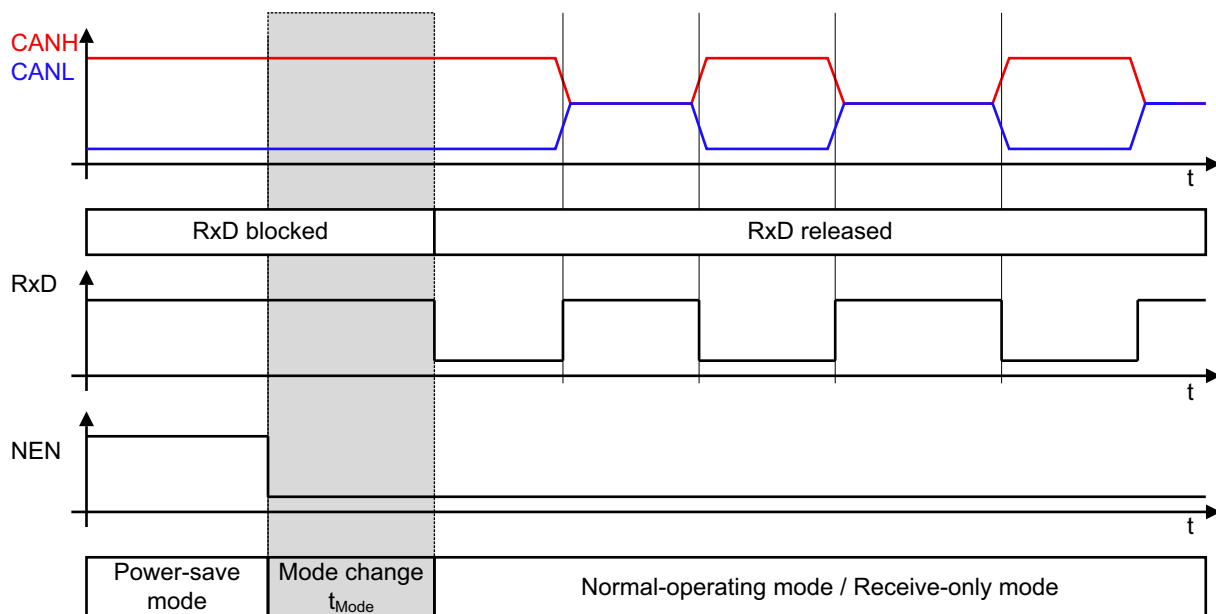

**Figure 10** RxD Behavior during Mode Change

The RxD output pin is not blocked nor be set to “high” during the following mode changes:

- Normal-operating mode → Receive-only mode
- Receive-only mode → Normal-operating mode

## 8 Failure Management

This chapter describes typical bus communication failures.

### 8.1 TxD Dominant Time-out Detection

The TxD dominant time-out detection of TLE7250 protects the CAN bus from being permanently driven to dominant level. When detecting a TxD dominant time-out, the TLE7250 disables the transmitter in order to release the CAN bus. Without the TxD dominant time-out detection, a CAN bus would be clamped to the dominant level and therefore would block any data transmission on the CAN bus. This failure may occur for example due to TxD pin shorted to ground.

The TxD dominant time-out detection can be reset after a dominant to recessive transition at the TxD pin. A “high” signal must be applied to the TxD input for at least  $t_{\text{TxD\_release}} = 200 \text{ ns}$  to reset the TxD dominant timer.

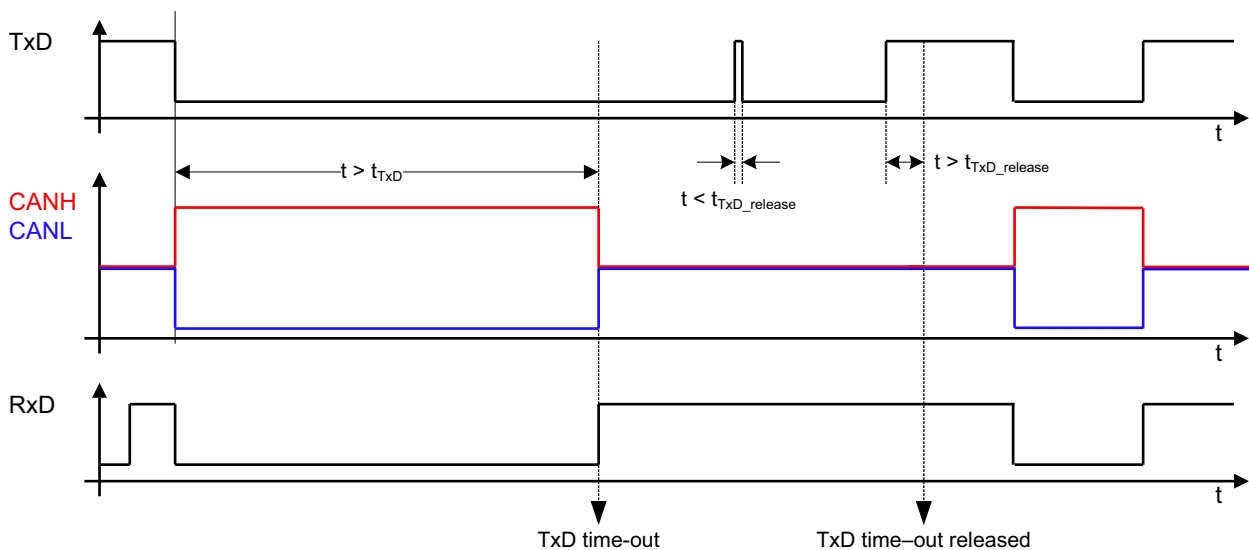

Figure 11 Resetting TxD Dominant Time-out Detection

If a TxD Dominant Time-out is present, then a mode change to Power-save mode clears the TxD dominant timer state.

### 8.2 Minimum Baud Rate and Maximum TxD Dominant Phase

Due to the TxD dominant time-out detection of the TLE7250 the maximum TxD dominant phase is limited by the minimum TxD dominant time-out time  $t_{\text{TxD}} = 4.5 \text{ ms}$ . The CAN protocol allows a maximum of 11 subsequent dominant bits at TxD pin (worst case dominant bits followed immediately by an error frame). With a minimum value of 4.5 ms given in the datasheet and maximum possible 11 dominant bits, the minimum baud rate of the application must be higher than 2.44 kbit/s.

### 8.3 Short Circuit

**Figure 12** shows short circuit types on the HS CAN bus. The CANH and CANL pins are short circuit proof to GND and to supply voltage. A current limiting circuit protects the transceiver from damage. If the device heats up due to a permanent short at CANH or CANL, then the overtemperature protection switches off the transmitter. Depending on the type of short circuit on CANH and CANL, communication might be still possible. If only CANL is shorted to GND or only CANH is shorted to  $V_{BAT}$ , then dominant and recessive states may be recognized by the receiver. Timings and/or differential output voltages might be not valid according to ISO11898 but still in the range for the receiver working properly.

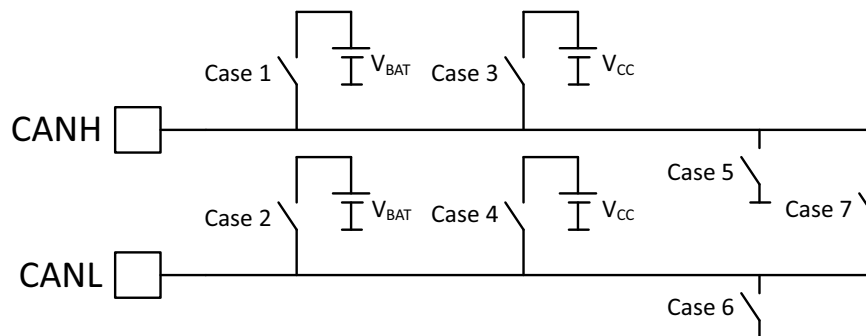

**Figure 12 HS CAN Bus Short Circuit Types**

Communication on the HS CAN bus is blocked in the following cases:

- CANH and CANL shorted (Case7)
- CANH shorted to GND (Case 5)
- CANL shorted to  $V_{BAT}$  (Case 2) or  $V_{CC}$  (Case 4)

If a short circuit occurs, the  $V_{CC}$  supply current for the transceiver can increase significantly. It is recommended to dimension the voltage regulator for the worst case, especially when  $V_{CC}$  also supplies the microcontroller.  $V_{CC}$  supply current only increases in dominant state. The recessive current remains almost unchanged.

#### CANH shorted to GND

The datasheet specifies a maximum short circuit current of 100mA. Transmitting a dominant state to the bus, 5V is shorted to GND through the transmitter output stage. Power dissipation with 10% duty cycle (DCD) is:

$$P = DCD \times U \times I = 0.1 \times 5V \times 100mA = 0.05W.$$

The average fault current with worst case parameters and assuming a realistic duty cycle of 10% is:

$$I_{CC, Fault} = I_{CC, rec} \times 0.9 + I_{CANH, SC} \times 0.1 = 13.6mA.$$

#### CANL shorted to $V_{BAT}$

If CANL is shorted to  $V_{BAT}$ , then the current through the CANL output stage is even higher and the device heats up faster. The datasheet specifies a maximum short circuit current of 100mA. When transmitting a dominant state to the bus,  $V_{BAT}$  is shorted to GND through the transmitter output stage. Assuming a realistic duty cycle of 10% for this case and the power dissipation is:

$$P = DCD \times U \times I = 0.1 \times V_{BAT} \times 100mA = 0.1 \times 18V \times 100mA = 0.18W.$$

#### CANH shorted to $V_{BAT}$

Short circuit of CANH to  $V_{BAT}$  can result in a permanent dominant state on the HS CAN bus, due to the voltage drop at the termination resistor. Therefore the termination resistor has to be chosen accordingly. If a short circuit of CANH to  $V_{BAT}$  occurs, then the power loss in the termination resistor must be taken into account. **Figure 13** shows the current in case CANH is shorted to  $V_{BAT}$ . When transmitting a dominant state to the bus, the current flows through the termination resistor and CANL to GND. Power loss in the termination resistor and



## Failure Management

CANL assuming a battery voltage of 18 V and a duty cycle of 10% is:

$$P_{\text{Loss\_Termination}} = 0.1 \times (R_{\text{Termination}} \times I_{\text{CANL,SC}}) \times I_{\text{CANL,SC}} = (60\Omega \times 100\text{mA}) \times 100\text{mA} = 0.6\text{W}$$

$$P_{\text{Loss\_CANL}} = 0.1 \times (V_{\text{BAT}} - (R_{\text{Termination}} \times I_{\text{CANL,SC}})) \times I_{\text{CANL,SC}} = 0.1 \times (18\text{V} - 6\text{V}) \times 100\text{mA} = 0.1 \times 12\text{V} \times 100\text{mA} = 0.12\text{W}$$

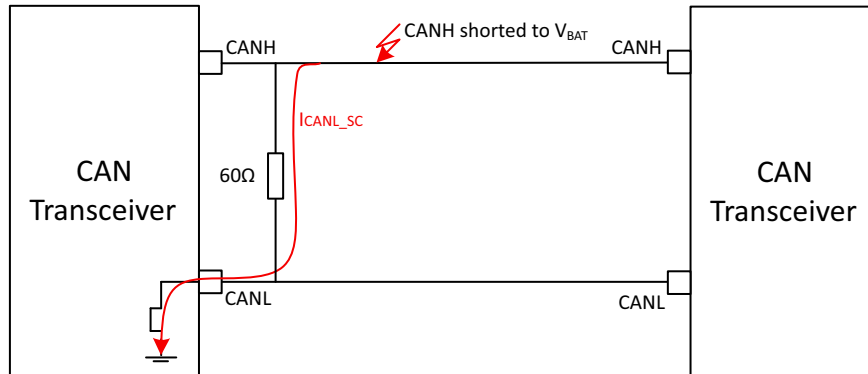

Figure 13 Current Flowing in Case of a Short Circuit CANH to  $V_{\text{BAT}}$

### 8.4 TLE7250 Junction Temperature

In Normal-operating mode highest power dissipation occurs with 50% duty cycle (D) at an ambient temperature of 150 °C:

$$P_{\text{NM,MAX}} = D \times (I_{\text{CC,R}} \times V_{\text{CC,max}}) + D \times (I_{\text{CC,D}} \times V_{\text{CC,max}}) + (I_{\text{O}} \times V_{\text{IO,max}}) =$$

$$= 0.5 \times (4 \text{ mA} \times 5.5 \text{ V}) + 0.5 \times (60 \text{ mA} \times 5.5 \text{ V}) + (1.5 \text{ mA} \times 5.5 \text{ V}) = 184.25 \text{ mW}.$$

Junction temperature increases due to power dissipation and depending on the package.

However, typical conditions are more like this: ambient temperature is below 150 °C, overall duty cycle is less than 50%, and supply voltages  $V_{\text{CC}}$  and  $V_{\text{IO}}$  have their typical values instead of maximum values.

Power dissipation is much lower for such typical conditions:

$$P_{\text{NM,AVG}} = D \times (I_{\text{CC,R,Typ}} \times V_{\text{CC,AVG}}) + D \times (I_{\text{CC,D,Typ}} \times V_{\text{CC,AVG}}) + (I_{\text{O,Typ}} \times V_{\text{IO,AVG}}) =$$

$$0.9 \times (2 \text{ mA} \times 5 \text{ V}) + 0.1 \times (38 \text{ mA} \times 5 \text{ V}) + (1 \text{ mA} \times 3.3 \text{ V}) = 23.3 \text{ mW}.$$

Table 4 Increase of Junction Temperature  $\Delta T_j$

Package	$R_{\text{thja}}$	$\Delta T_j$	Conditions
PG-DSO-8	120 K/W	22.1 K	$P_{\text{NM,MAX}} = 184.25 \text{ mW}$ ; $T_{\text{amb}} = 150 \text{ }^\circ\text{C}$ ;
PG-TSON-8	65 K/W	12 K	50% duty cycle; $V_{\text{CC}} = V_{\text{CC,max}}$ ; $V_{\text{IO}} = V_{\text{IO,max}}$
PG-DSO-8	120 K/W	2.8 K	$P_{\text{NM,AVG}} = 23.3 \text{ mW}$ ; $T_{\text{amb}} = 80 \text{ }^\circ\text{C}$ ;
PG-TSON-8	65 K/W	1.5 K	10% duty cycle; $V_{\text{CC}} = V_{\text{CC,typ}}$ ; $V_{\text{IO}} = V_{\text{IO,typ}}$
PG-DSO-8	120 K/W	6K	Short Circuit CANH to GND
PG-TSON-8	65 K/W	3.25K	10% duty cycle;
PG-DSO-8	120 K/W	21.62K	Short Circuit CANL to $V_{\text{BAT}}$
PG-TSON-8	65 K/W	11.72K	10% duty cycle;

If a short circuit occurs, then the TLE7250 heats up. The higher the duty cycle, the higher the power dissipation. If a thermal shutdown occurs due to high temperature, then the receiver is still enabled with only the transmitter disabled. The behavior is identical to Receive-only mode.

## 9 PCB Layout Recommendations for CAN FD

The following layout rules should be considered to achieve best performance of the transceiver and the ECU:

- TxD and RxD connections to microcontroller should be as short as possible.
- For each microcontroller the TxD driver output stage current capability may vary depending on the selected port and pin. The driver output stage current capability should be strong enough to guarantee a maximum propagation delay from  $\mu\text{C}$  port to transceiver TxD pin of less than 30ns.
- Place two individual 100nF capacitors close to  $V_{\text{CC}}$  and  $V_{\text{IO}}$  pins for local decoupling. Due to their low resistance and lower inductance compared to other capacitor types, it is recommended to use ceramic capacitors.
- If a common mode choke is used, it has to be placed as close as possible to the bus pins CANH and CANL.
- Avoid routing CANH and CANL in parallel to fast-switching lines or off-board signals in order to reduce noise injection to the bus.
- It is recommended to place the transceiver as close as possible to the ECU connector in order to minimize track length of bus lines.
- Avoid routing digital signals in parallel to CANH and CANL.
- CANH and CANL tracks should have the same length. They should be routed symmetrically close together with smooth edges.
- GND connector should be placed as close as possible to the transceiver.
- Avoid routing transceiver GND and microcontroller GND in series in order to reduce coupled noise to the transceiver. This also applies for high current applications, where the current should not flow through the GND line of transceiver and microcontroller in serial.
- Avoid routing transceiver  $V_{\text{CC}}$  supply and microcontroller  $V_{\text{CC}}$  supply in series in order to reduce coupled noise to the transceiver.
- Same dimensions and lengths for all wire connections from the transceiver to CMC and/or termination.
- In case an external ESD protection circuit is used, make sure the total capacitance is lower than 50pF. Use equal ESD protection for CANH and CANL in order to improve signal symmetry.
- For CAN FD application it is recommended to use a Common Mode Choke with  $100\mu\text{H}$  impedance and a Split termination with a capacitance of  $4.7\text{nF}$  in order to achieve excellent EME performance in automotive applications.

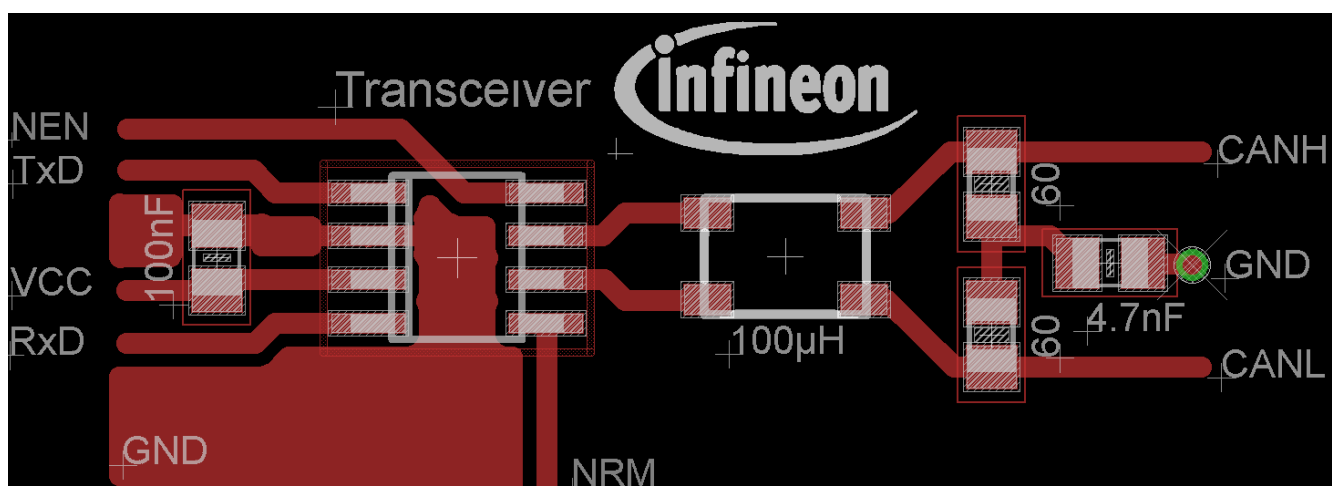

Figure 14 Example CAN transceiver PCB layout

References

## 10 References

- 1) [Data Sheet TLE7250SJ / TLE7250LE, HS CAN Transceiver, Infineon Technologies AG](#)
- 2) [White Paper - The CAN FD Physical Layer, Infineon Technologies AG](#)
- 3) [Infineon Automotive Transceivers Homepage](#)

## Terms and Abbreviations

**Table 5** Terms and Abbreviations

CMC	Common mode choke
EMC	Electromagnetic compatibility
EME	Electromagnetic emission
EMI	Electromagnetic interference
EOS	Electrical overstress
ESD	Electrostatic discharge
ESR	Equivalent Series Resistance
“high”	logical high
“low”	logical low

---

Revision History

## 11 Revision History

Revision	Date	Changes
1.2	2016-06-20	Editorial Changes; Added <a href="#">Chapter 9</a> PCB Layout Recommendations; Added <a href="#">Chapter 10</a> References;
1.1	2016-05-03	TxD Dominant time-out detection updated <a href="#">Figure 11</a> ;
1.0	2016-01-25	Application Note created

#### Trademarks of Infineon Technologies AG

$\mu$ HVIC™,  $\mu$ IPM™,  $\mu$ PFC™, AU-ConvertIR™, AURIX™, C166™, CanPAK™, CIPOS™, CIPURSE™, CoolDP™, CoolGaN™, COOLIR™, CoolMOS™, CoolSET™, CoolSiC™, DAVE™, DI-POL™, DirectFET™, DrBlade™, EasyPIM™, EconoBRIDGE™, EconoDUAL™, EconoPACK™, EconoPIM™, EiceDRIVER™, eupec™, FCOS™, GaNpowIR™, HEXFET™, HITFET™, HybridPACK™, iMOTION™, IRAM™, ISOFACE™, IsoPACK™, LEDrivr™, LITIX™, MIPAQ™, ModSTACK™, my-d™, NovalithIC™, OPTIGA™, OptiMOS™, ORIGA™, PowIRaudio™, PowIRstage™, PrimePACK™, PrimeSTACK™, PROFET™, PRO-SIL™, RASIC™, REAL3™, SmartLEWIS™, SOLID FLASH™, SPOC™, StrongIRFET™, SupIRBuck™, TEMPFET™, TRENCHSTOP™, TriCore™, UHVIC™, XHP™, XMC™.

Trademarks updated November 2015

#### Other Trademarks

All referenced product or service names and trademarks are the property of their respective owners.

Edition 2016-06-20

Published by

Infineon Technologies AG

81726 Munich, Germany

© 2006 Infineon Technologies AG.

All Rights Reserved.

Do you have a question about any aspect of this document?

Email: [erratum@infineon.com](mailto:erratum@infineon.com)

Document reference  
Z8F54978220

#### IMPORTANT NOTICE

The information contained in this application note is given as a hint for the implementation of the product only and shall in no event be regarded as a description or warranty of a certain functionality, condition or quality of the product. Before implementation of the product, the recipient of this application note must verify any function and other technical information given herein in the real application. Infineon Technologies hereby disclaims any and all warranties and liabilities of any kind (including without limitation warranties of non-infringement of intellectual property rights of any third party) with respect to any and all information given in this application note.

The data contained in this document is exclusively intended for technically trained staff. It is the responsibility of customer's technical departments to evaluate the suitability of the product for the intended application and the completeness of the product information given in this document with respect to such application.

For further information on technology, delivery terms and conditions and prices, please contact the nearest Infineon Technologies Office ([www.infineon.com](http://www.infineon.com)).

#### WARNINGS

Due to technical requirements products may contain dangerous substances. For information on the types in question please contact your nearest Infineon Technologies office.

Except as otherwise explicitly approved by Infineon Technologies in a written document signed by authorized representatives of Infineon Technologies, Infineon Technologies' products may not be used in any applications where a failure of the product or any consequences of the use thereof can reasonably be expected to result in personal injury.