

# EVAL-M1-301F User Guide

## iMOTION™ Modular Application Design Kit

### About this document

#### Scope and purpose

This user guide provides an overview of the evaluation board EVAL-M1-301F including its main features, key data, pin assignments and mechanical dimensions.

EVAL-M1-301F is an evaluation board as part of the iMOTION™ modular application design kit (MADK). This board features and demonstrates Infineon's advanced motion control engine (MCE 2.0) technology for permanent magnet motor drives over the full speed range.

The evaluation board EVAL-M1-301F was developed to support customers during their first steps designing applications using permanent magnet motors via sensorless sinusoidal control.

The IMC301A contains two cores – the motion control engine (MCE) and an additional microcontroller (MCU). MCE support files and documentation will be available on the Infineon website. The MCU-related CMSIS pack can be downloaded from the KEIL IDE, and this document does not cover it.

#### Intended audience

This User Guide is intended for all technical specialists who have a knowledge of motor control and high-power electronics converters. The board is intended for use under laboratory conditions.

This board will be used during design-in, for evaluation and measurement of characteristics, and proof of data sheet specifications.

*Note: PCB and auxiliary circuits are NOT optimized for final customer design.*

### Table of contents

<b>About this document</b> .....	<b>1</b>
<b>Table of contents</b> .....	<b>1</b>
<b>1 Important notice</b> .....	<b>3</b>
<b>2 Safety precautions</b> .....	<b>5</b>
<b>3 Introduction</b> .....	<b>6</b>
<b>4 EVAL-M1-301F main features</b> .....	<b>7</b>
4.1 Functional description.....	8
4.2 EVAL-M1-301F board specifications.....	9
4.3 Connectors and pin assignment.....	10
<b>5 Getting started with EVAL-M1-301F</b> .....	<b>14</b>
5.1 Setting up the Motion Control Engine (MCE).....	15
5.2 iMOTION™ development tools and software.....	17
5.2.1 MCEWizard setup overview.....	17
5.2.2 MCEDesigner setup overview.....	20

**Table of contents**

5.3	Working with the MCU .....	22
<b>6</b>	<b>Hardware description of EVAL-M1-301F .....</b>	<b>23</b>
6.1	Motor current feedback circuitry .....	23
6.1.1	Motor shunt configuration .....	23
6.1.2	Motor external current feedback configuration and calculation .....	23
6.1.3	Amplifier-gain configuration .....	25
6.2	EVAL-M1-301F analog inputs and their MCEWizard setup .....	26
6.2.1	DC bus sensing configuration .....	26
6.2.2	NTC shutdown value calculation and configuration .....	27
6.3	Schematics overview .....	29
6.4	PCB layout overview .....	29
<b>7</b>	<b>Bill of materials.....</b>	<b>34</b>
<b>8</b>	<b>Reference.....</b>	<b>37</b>
	<b>Revision history.....</b>	<b>38</b>

## **1 Important notice**

**Attention:** *The Evaluation Boards and Reference Boards as well as the information in this document are solely intended to support designers of applications in evaluating the use of products from Infineon Technologies for their intended applications.*

*Environmental conditions have been considered in the design of the Evaluation Boards and Reference Boards provided by Infineon Technologies. The design of the Evaluation Boards and Reference Boards has been tested by Infineon Technologies only as described in this document. The design is not qualified in terms of safety requirements, manufacturing and operation over the entire operating temperature range or lifetime.*

*The Evaluation Boards and Reference Boards provided by Infineon Technologies are subject to functional testing only under typical load conditions. Evaluation Boards and Reference Boards are not subject to the same procedures as regular products regarding returned material analysis (RMA), process change notification (PCN) and product discontinuation (PD).*

*Evaluation Boards and Reference Boards are not commercialized products, and are solely intended for evaluation and testing purposes. In particular, they shall not be used for reliability testing or production. The Evaluation Boards and Reference Boards may therefore not comply with CE or similar standards (including but not limited to the EMC Directive 2004/EC/108 and the EMC Act) and may not fulfill other requirements of the country in which they are operated by the customer. The customer shall ensure that all Evaluation Boards and Reference Boards will be handled in a way which is compliant with the relevant requirements and standards of the country in which they are operated.*

*The Evaluation Boards and Reference Boards as well as the information provided in this document are addressed only to qualified and skilled technical staff, for laboratory usage, and shall be used and managed according to the terms and conditions set forth in this document and in other related documentation supplied with the respective Evaluation Board or Reference Board.*

*It is the responsibility of the customer's technical departments to evaluate the suitability of the Evaluation Boards and Reference Boards for the intended application, and to evaluate the completeness and correctness of the information provided in this document with respect to such application.*

*The customer accepts that the Evaluation Boards and Reference Boards are not intended to be used in life-endangering applications such as medical, nuclear, military, life-critical or other applications, where failure of the Evaluation Boards and Reference Boards, or any results from the use thereof, can reasonably be expected to result in personal injury.*

*The Evaluation Boards and Reference Boards and any information in this document is provided "as is" and Infineon Technologies disclaims any warranties, express or implied, including but not limited to warranties of non-infringement of third party rights and implied warranties of fitness for any purpose, or for merchantability.*

*Infineon Technologies shall not be responsible for any damages resulting from the use of the Evaluation Boards and Reference Boards and/or from any information provided in this*

**Important notice**

*document. The customer is obliged to defend, indemnify and hold Infineon Technologies harmless from and against any claims or damages arising out of or resulting from any use thereof.*

*Infineon Technologies reserves the right to modify this document and/or any information provided herein at any time without further notice.*

**Safety precautions**

## 2 Safety precautions

Please note the following warnings regarding the hazards associated with development systems.

**Table 1 Safety precautions**

	<p><b>Warning:</b> The DC link potential of this board is up to 1000 V<sub>DC</sub>. When measuring voltage waveforms by oscilloscope, high voltage differential probes must be used. Failure to do so may result in personal injury or death.</p>
	<p><b>Warning:</b> The evaluation or reference board contains DC bus capacitors which take time to discharge after removal of the main supply. Before working on the drive system, wait five minutes for capacitors to discharge to safe voltage levels. Failure to do so may result in personal injury or death. Darkened display LEDs are not an indication that capacitors have discharged to safe voltage levels.</p>
	<p><b>Warning:</b> The evaluation or reference board is connected to the grid input during testing. Hence, high-voltage differential probes must be used when measuring voltage waveforms by oscilloscope. Failure to do so may result in personal injury or death. Darkened display LEDs are not an indication that capacitors have discharged to safe voltage levels.</p>
	<p><b>Warning:</b> Remove or disconnect power from the drive before you disconnect or reconnect wires, or perform maintenance work. Wait five minutes after removing power to discharge the bus capacitors. Do not attempt to service the drive until the bus capacitors have discharged to zero. Failure to do so may result in personal injury or death.</p>
	<p><b>Caution:</b> The heat sink and device surfaces of the evaluation or reference board may become hot during testing. Hence, necessary precautions are required while handling the board. Failure to comply may cause injury.</p>
	<p><b>Caution:</b> Only personnel familiar with the drive, power electronics and associated machinery should plan, install, commission and subsequently service the system. Failure to comply may result in personal injury and/or equipment damage.</p>
	<p><b>Caution:</b> The evaluation or reference board contains parts and assemblies sensitive to electrostatic discharge (ESD). Electrostatic control precautions are required when installing, testing, servicing or repairing the assembly. Component damage may result if ESD control procedures are not followed. If you are not familiar with electrostatic control procedures, refer to the applicable ESD protection handbooks and guidelines.</p>
	<p><b>Caution:</b> A drive that is incorrectly applied or installed can lead to component damage or reduction in product lifetime. Wiring or application errors such as undersizing the motor, supplying an incorrect or inadequate AC supply, or excessive ambient temperatures may result in system malfunction.</p>
	<p><b>Caution:</b> The evaluation or reference board is shipped with packing materials that need to be removed prior to installation. Failure to remove all packing materials that are unnecessary for system installation may result in overheating or abnormal operating conditions.</p>

**Introduction**

### **3 Introduction**

The EVAL-M1-301F evaluation board is a part of the iMOTION™ modular application design kit for drives (iMOTION™ MADK). In order to run a motor, the mating power board is required to interface this evaluation board.

The MADK platform is intended for use with various power stages with different control boards. These boards can easily be interfaced through the 20-pin iMOTION™ MADK M1, or the 30-pin iMOTION™ MADK M3 interface connector. This board is equipped with a 20-pin M1 connector and is intended for running a single motor.

This evaluation board is designed to give comprehensible solutions of sensorless control of permanent magnet motors over the full speed range. It provides Hall-sensor based or sensorless controls applying 3-phase and type 3 of 2-phase modulation. PC interface is via a micro-USB connector and the on-board debugger is galvanically isolated. The PC interface provides a UART connection to the MCE as well as a serial wire debug (SWD) channel to the MCU.

The EVAL-M1-301F evaluation board is available from Infineon. The features of this board are described in the main features chapter of this document, whereas the remaining paragraphs provide information to enable the customers to copy, modify and qualify the design for production according to their own specific requirements.

Environmental conditions were considered in the design of the EVAL-M1-301F, but the board is not qualified in terms of safety requirements or manufacturing and operation over the entire operating temperature range or lifetime. The boards provided by Infineon are subject to functional testing only.

Evaluation boards are not subject to the same procedures as regular products regarding returned material analysis (RMA), process change notification (PCN) and product discontinuation (PD). Evaluation boards are intended to be used under laboratory conditions by technical specialists only.

Figure 1 shows the evaluation board EVAL-M1-301F. This document explains the features and details of this board as well as the control IC, IMC301A-F064.

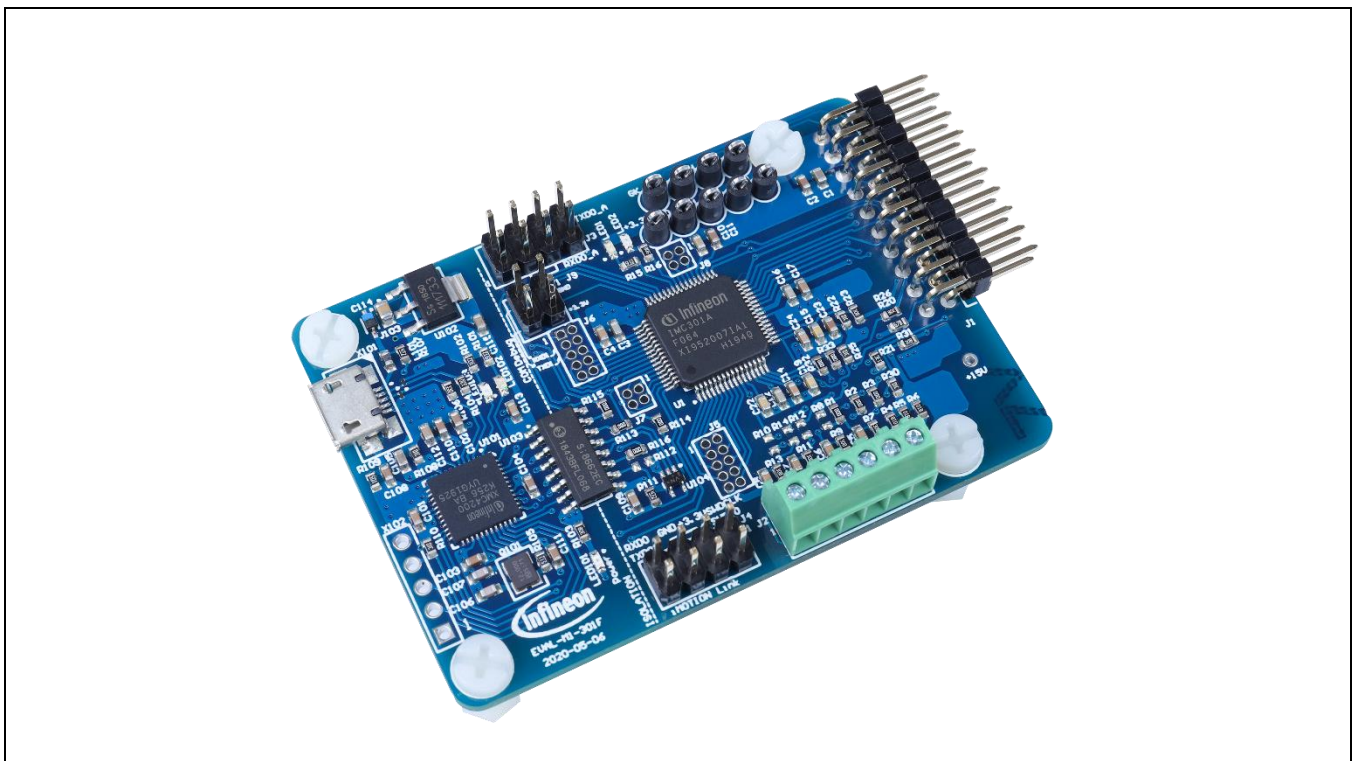

**Figure 1 Evaluation board EVAL-M1-301F**

## **4 EVAL-M1-301F main features**

EVAL-M1-301F is an evaluation control board for motor control applications. The kit demonstrates Infineon's motion control IC technology.

### **The evaluation board characteristics:**

- Control board for any permanent magnet motor with field oriented control
- Compatible with all M1 boards
- Current sensing via single or leg shunt
- Sensorless or Hall-sensor based operation (connector for analog or digital hall sensors)
- Galvanic isolation between motor and pc interface
  - On-board debugger is powered by USB interface
  - Motor controller is powered from power board
- Micro-USB connector to **on-board debugger**
  - Access to MCE via virtual COM port
  - Access to MCU via SWD debug channel (Segger® J-Link light)
- **Optional** pin headers available
- RoHS complaint
- PCB size is 65 x 45 mm

### **Main features of the IMC301A-F064 motion control IC include:**

- Dual core device with MCE and MCU connected via high speed serial link
- **MCE and MCU run** in parallel and **independently** from each other
- MCE controls the motor
- MCU is used for system tasks, communication, monitoring, data logging, any anything else
- **High-speed serial link (JCOM)** between MCE and MCU for commanding the MCE
- **MCE (Motion Control Engine)** as ready-to-use solution for variable speed drives
  - Field-oriented control (FOC) for permanent magnet synchronous motor (PMSM)
  - Space vector PWM with sinusoidal commutation and integrated protection features
  - Capable of 3-phase and type 3 of 2-phase modulation
  - Multiple motor parameter support
  - Flexible host interface options for speed commands: UART, I2C, SPI, PWM or analog signal
  - UL / CSA 60730 certified (Class B)
- Additional **microcontroller (MCU)** based on Arm® Cortex® M0 core
  - 96/48 MHz clock, 128 /16 KByte Flash/SRAM
  - RTC/ systick/ watchdog timer, fast interrupt controller
  - Various serial communication interfaces (UART, I2C, SPI)
  - Peripheral set targeting system control and communication
- 3.3 V (default) or 5 V VDD power supply
- Scalable package options



**EVAL-M1-301F main features**

**4.1 Functional description**

Figure 2 shows a typical block diagram of a motor control application using the IMC301A-F064. The IMC301A-F064 provides a built-in, closed loop and sensorless control algorithm using the unique flexible motion control engine (MCE) for permanent magnet motors. The MCE™ consists of a collection of control elements, motion peripherals, a dedicated motion control sequencer and internal memory to map internal signal nodes. IMC301A-F064 also employs a unique single shunt current reconstruction circuit in addition to a leg shunt current sensing circuit to eliminate additional analog/digital circuitry.

The integrated MCU is based on an Arm® Cortex® M0 core. It is internally connected to the MCE via a fast serial port. The debug interface (SWD) is routed to the on-board debug interface via a galvanic isolation.

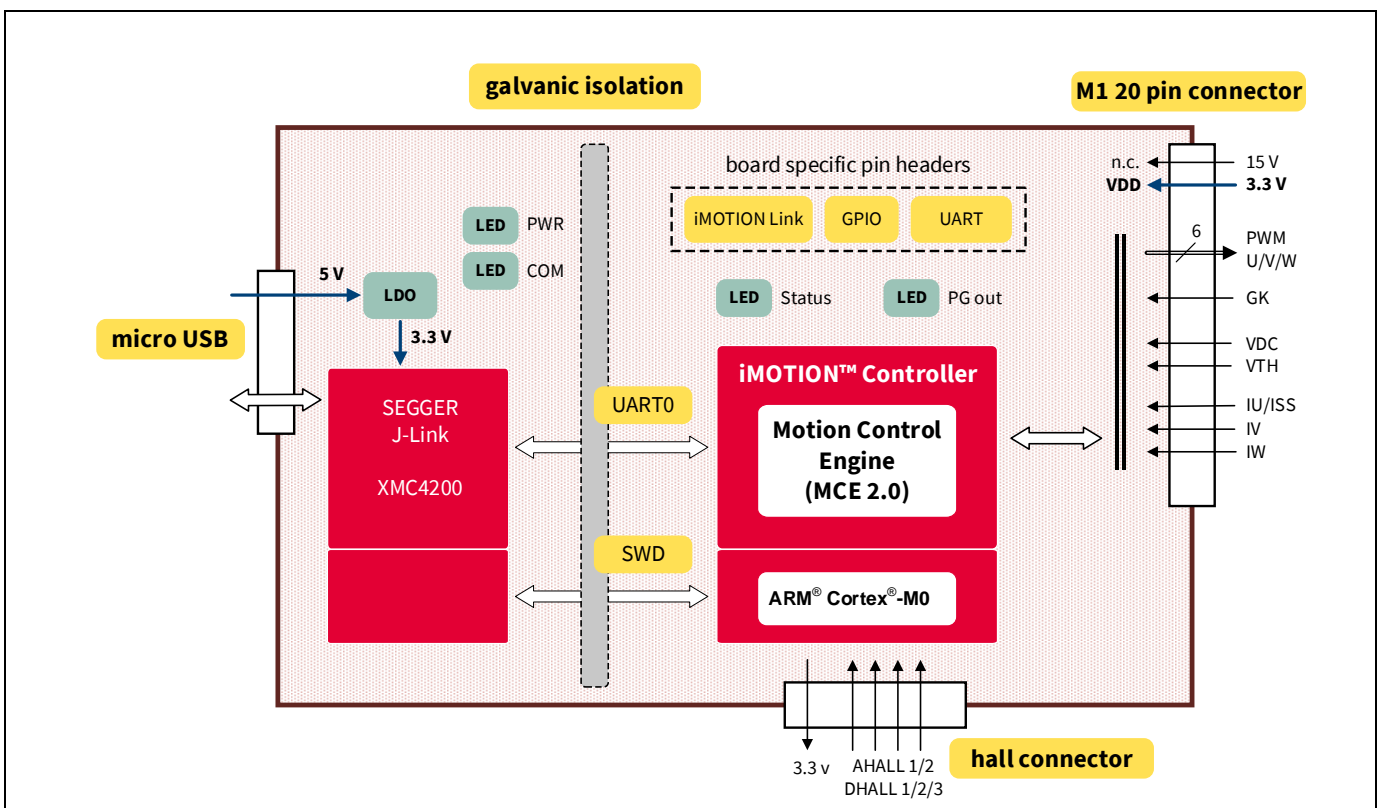

**Figure 2 Block diagram of the EVAL-M1-301F**



## 4.2 EVAL-M1-301F board specifications

Table 2 depicts the key specifications of the evaluation board EVAL-M1-301F.

**Table 2 EVAL-M1-301F board specifications**

Parameters	Values	Conditions / comments
<b>Host interface (not isolated)</b>		
UART(TXD, RXD)	0 - VDD	UART0, UART0_A, UART1_A
AIN	0 - VDD	Analog input
DIN	0 - VDD	Digital input
DOUT	0 - VDD	Digital output
<b>Input</b>		
VDD	3.3 V (default), 5 V	Controller supply voltage
<b>DC bus</b>		
DC bus scaling	8.20 counts/V	13.3 kΩ resistor on control board, and 2 MΩ resistor on power board
DC bus sensing range	499.54 V max	
<b>Current feedback</b>		
Motor internal current feedback amplifier gain	1, 3, 6, 12	Configured by MCEWizard
Motor current sensing device	0 - VDD/Gain	Single shunt resistor Leg shunt resistor
Motor current op-amp configuration	Non-Inverting	Default setting
Motor current external amplification gain	0.833	
Resolution	12-bit	PCB design may reduce the resolution
<b>Protection</b>		
NTC temperature shutdown value	0 - VDD (configured by MCEWizard)	
<b>PCB characteristics</b>		
Material	FR4, 1.6 mm thickness Copper thickness = 1 oz (35 μm)	
Dimension	65 mm x 45 mm	

**EVAL-M1-301F main features**

**4.3 Connectors and pin assignment**

The EVAL-M1-301F consists of several functional groups which enable an out-of-the-box, fully functional motor control system combined with additional interfaces and test points for more advanced use cases. Figure 3 shows the functional groups of the EVAL-M1-301F evaluation board.

Key information about the connections of the EVAL-M1-301F evaluation board is described below. Only the USB interface and the M3 connector to the power board are mandatory, all other interfaces are optional.

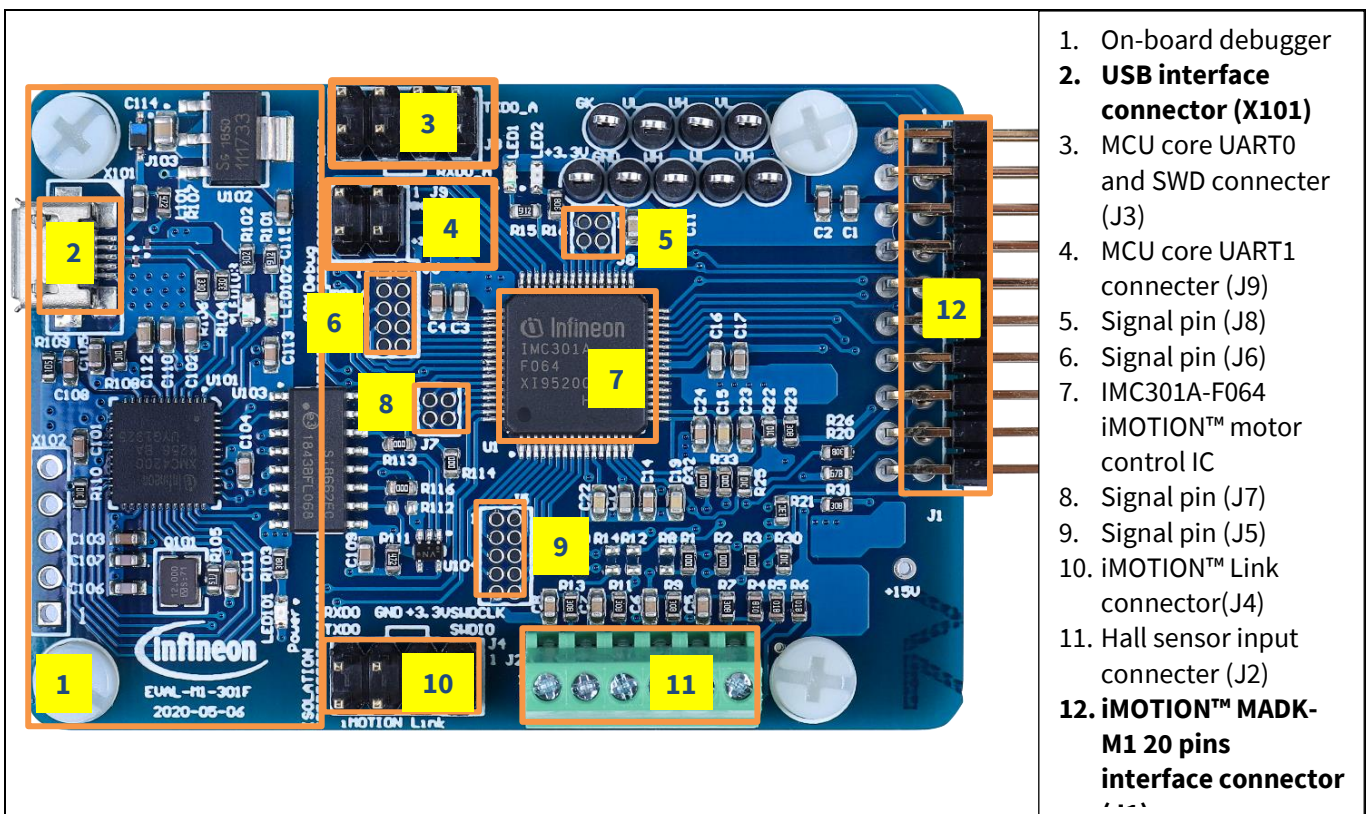

**Figure 3 Functional groups of the EVAL-M1-301F evaluation board's top side**

Table 3 provides the pin assignments of the iMOTION™ MADK-M1 20-pin interface connector J1. This connector is the interface to the power board.

**Table 3 J1- iMOTION™ MADK-M1 20-pin interface connector for control board**

Pin No.	Pin	Details
1	PWMUH	3.3 V compatible logic output for high side gate driver-Phase U
2	GND	Ground
3	PWMUL	3.3 V compatible logic output for low side gate driver-Phase U
4	GND	Ground
5	PWMVH	3.3 V compatible logic output for high side gate driver-Phase V
6	+3.3V	On board 3.3 V supply
7	PWMVL	3.3 V compatible logic output for low side gate driver-Phase V
8	+3.3V	On board 3.3 V supply

**EVAL-M1-301F main features**

Pin No.	Pin	Details
9	PWMWH	3.3 V compatible logic output for high side gate driver-Phase W
10	IU+	Shunt voltage phase U
11	PWMWL	3.3 V compatible logic output for low side gate driver-Phase W
12	IU-	Ground
13	GK	Gate kill signal – active low when over current is detected
14	DCBSENSE	DC bus positive voltage, scaled in 0-3.3 V range by a voltage divider
15	VTH	Thermistor input
16	IV+	Shunt voltage phase V
17	IV-	Ground
18	IW+	Shunt voltage phase W
19	IW-	Ground
20	VCC	Defined for 15 V power supply (not used in this board)

The EVAL-M1-301F supports the use of both digital as well as analog Hall sensors. Table 4 includes the details of the Hall sensor interface connector.

**Table 4 J2- Hall sensor Input**

Pin	Name	Pin name connectors
1	GND	Ground
2	DHAL1/AHAL1+	Digital Hall sensor Input1 or analog Hall sensor Input1+
3	DHAL2/AHAL1-	Digital Hall sensor Input2 or analog Hall sensor Input1-
4	DHAL3/AHAL2+	Digital Hall sensor Input3 or analog Hall sensor Input2+
5	AHAL2-	Analog Hall sensor Input2-
6	+3.3 V	+3.3V power supply

The IMC300 series of dual core controllers is the most flexible solution in terms of application support. A large number of pins is made available on pin headers supporting multiple customer-use cases.

Table 5, Table 6, Table 7, Table 8, Table 9, and Table 10 include the details of the respective signal pins for the application microcontroller (MCU). Functionality of the pins is flexible and can be assigned via the respective program running on the MCU. For details please refer to the IMC300 hardware reference manual.

**Table 5 J3- MCU UART0 and SWD**

Pin	Name	Pin name connectors
1	SWDCLK	User serial debug clock
2	SWDIO	User serial debug I/O
3	+3.3 V	+3.3 V power supply
4	GND	Ground
5	GND	Ground
6	+3.3 V	+3.3 V power supply

**EVAL-M1-301F main features**

Pin	Name	Pin name connectors
7	P2.0 (RXD0_A)	MCU serial port 0, RXD
8	P2.1 (TXD0_A)	MCU serial port 0, TXD

**Table 6 J4- iMOTION Link**

Pin	Name	Pin name connector
1	SWDCLK	User serial debug clock for MCU
2	SWDIO	User serial debug I/O for MCU
3	+3.3 V	+3.3 V power supply
4	GND	Ground
5	GND	Ground
6	+3.3 V	+3.3 V power supply
7	RXD0	Reception of UART0 for MCE
8	TXD0	Transmission of UART0 for MCE

**Table 7 J5- MCU IO connection**

Pin	Name	Pin name connector
1	P2.1 (TXD0_A)	Programmable I/O, or MCU serial port 0, TXD
2	P2.2	Programmable I/O
3	P2.0 (RXD0_A)	Programmable I/O , or MCU serial port 0, RXD
4	P2.6	Programmable I/O
5	P4.7	Programmable I/O
6	P2.8	Programmable I/O
7	P4.6	Programmable I/O
8	P2.10	Programmable I/O
9	GND	Ground
10	P2.11	Programmable I/O

**Table 8 J6- MCU I/O connection**

Pin	Name	Pin name connector
1	P1.1	Programmable I/O
2	P1.0	Programmable I/O
3	+3.3 V	+3.3 V power supply
4	GND	Ground
5	P0.13	Programmable I/O
6	P0.8	Programmable I/O
7	P0.12	Programmable I/O
8	P0.9	Programmable I/O
9	P0.11	Programmable I/O
10	P0.10	Programmable I/O

**EVAL-M1-301F main features**

**Table 9 J7- MCU I/O connection**

Pin	Name	Pin name connector
1	P4.1	Programmable I/O
2	P4.2	Programmable I/O
3	P4.0	Programmable I/O
4	P4.3	Programmable I/O

**Table 10 J9- MCU UART1**

Pin	Name	Pin Name Connector
5	GND	Ground
6	+3.3 V	VDD
7	P4.4 (RXD1_A)	MCU serial port 1, RXD
8	P4.5 (TXD1_A)	MCU serial port 1, TXD

The motion control engine (MCE) in the IMC300 can read and drive pins directly and it also supports scripting. Table 11 lists the MCE I/O pins that are made available. For functionality please refer to the Motion Control Engine Software Reference Manual.

**Table 11 J8- MCE GPIO pins**

Pin	Name	Pin name connector
1	GPIO12	User configurable I/O, digital
2	GPIO13	User configurable I/O, digital
3	GPIO15	User configurable I/O, digital
4	GPIO14	User configurable I/O, digital

## 5 Getting started with EVAL-M1-301F

In order to run the motor system, the following components are required:

- iMOTION™ MADK control board (EVAL-M1-301F)
- Matching MADK power board with M1 connector
- USB cable with micro-USB connector

A single USB interface is used to power the on-board debugger and interface to both the MCE as well as the MCU. This setup is shown below in Figure 4.

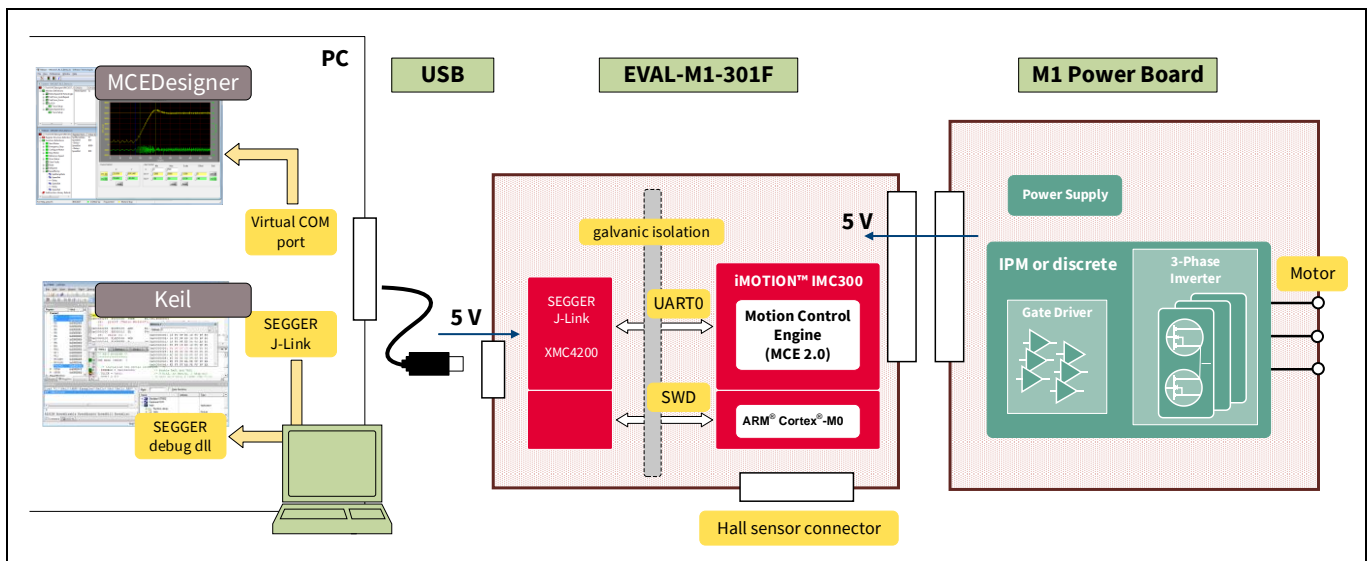

**Figure 4 Board setup and interfaces to the MCE and the MCU**

On the PC a virtual COM port is used to connect to the MCE, e.g. using the MCEDesigner. Chapter 5.1 describes the setup and usage of the MCE and the respective tools.

Connection to the SWD debug interface of the MCU is provided via the SEGGER debug DLL. This DLL is part of the installation of MCEDesigner but can also be installed and updated separately. The preferred C development environment like Keil µVision is used to download and debug code on the MCU. (see Chapter 5.2)

The iMOTION™ software tools, MCEDesigner and MCEWizard, are also required to initially set up the system, as well as to control and fine-tune the system performance to match users' exact needs. This chapter provides more details on setting up the system and getting started with the iMOTION™ MADK development platform.

The MCE and MCU in the IMC301A work independently from each other. Code for the MCU can be downloaded and debugged while the MCE is running the motor.

## **5.1 Setting up the Motion Control Engine (MCE)**

After downloading and installing the iMOTION™ PC tools (MCEWizard and MCEDesigner), the following steps need to be executed in order to run the motor. Refer to Chapters 5.2.1 and 5.2.2 as well as MCEWizard and MCEDesigner documentation for more information.

1. Get the latest IMC301A-F064 MCE software package available on [www.infineon.com/imotion-software](http://www.infineon.com/imotion-software) website.
2. Connect PC-USB connector on the on-board-debugger to the PC via USB cable.
3. Connect EVAL-M1-301F M1 20-pin interface connector (J1) to power board (for example EVAL-M1-05-065D, see Figure 5).
4. Use MCEWizard to enter the target motor's system and operating parameters, as well as the hardware parameters of the evaluation board, which will then be used to calculate controller's digital parameter set representing complete motor drive system. First click "Calculate" button on the "Verify & Save Page" and then save the drive parameter set into your project directory by clicking "Export to Designer file (.txt)". Saved Drive System Parameter File will be later used by the MCEDesigner; refer to Chapter 5.2.1 or MCEWizard user guide for more details.
5. Connect motor phase outputs to the motor.
6. Connect AC power to power input connector and power on system.
7. Start MCEDesigner tool and open MCEDesigner default configuration file (.irc) for IMC301A-F064 controller (IMC301A\_Vxxx.irc) by clicking "File" > "Open". IMC301A\_Vxxx.irc file is included in "IMC301A-F064 MCE Software Package" downloaded in step 1.
8. MCEDesigner should automatically connect to the EVAL-M1-301F control board using default COM port (indicated by green circle next to "COMx Up" status in the bottom frame of the MCEDesigner GUI). If it cannot establish the connection, change COM port by doing the following steps: ("System" window active) > Preferences > Connection > Connect using (Choose one of the other available COM ports from the drop-down menu).
9. In case the IMC301A-F064 IC on the EVAL-M1-301F is empty (not programmed), which will be indicated by the pop-up window message after connecting to the MCEDesigner, then use following steps to program the firmware and system parameters into the internal SRAM of iMOTION™ IC: Click "Tools" > "Programmer" and select "Program Firmware and Parameters." Browse and select the IMC301A-F064\_A\_Vxxx.ldf file which was included in the "IMC301A-F064 MCE Software Package" downloaded in step 1. Then browse and select the System Drive Parameters .txt file created in step 4. See chapter MCEDesigner setup overview 5.2.2 for more details.
10. In case the IMC301A-F064 IC firmware has already been loaded, use the following steps to program the system parameters into the internal SRAM of iMOTION™ IC: Click "Tools" > "Programmer" and select "Program Parameters." Browse and select the System Drive Parameters .txt file created in step 4. See chapter MCEDesigner setup overview 5.2.2 for more details.
11. Start the motor by clicking the green traffic light button in the control bar.



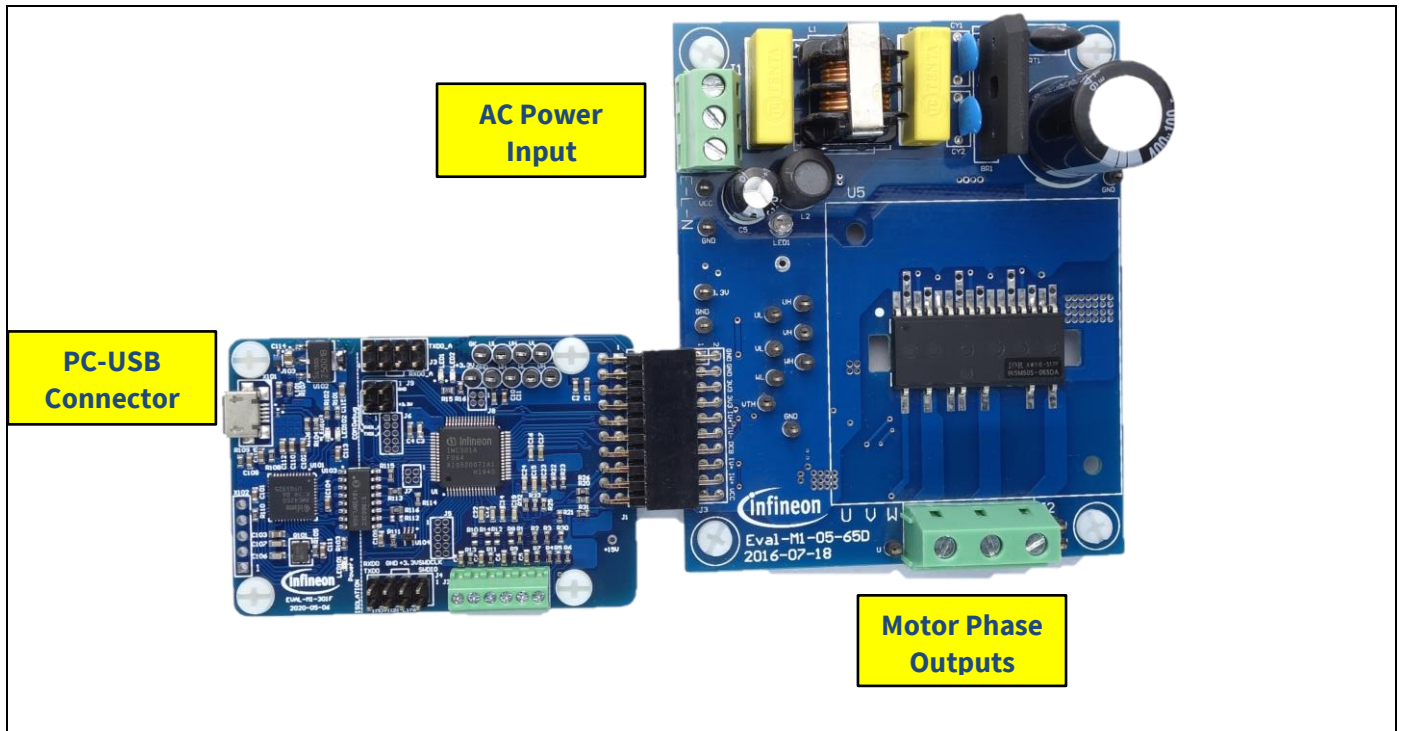

**Figure 5** System connection example using EVAL-M1-301F and EVAL-M1-05-65D

## 5.2 iMOTION™ development tools and software

The iMOTION™ Development Tool installers for MCEDesigner and MCEWizard are available for download via Infineon iMOTION™ website (<http://www.infineon.com/imotion-software>). All supported tools and software variants are listed there. Please visit this page periodically to check for tool/software updates.

The isolated on-board debugger provides the USB to UART bridge between the PC and the target iMOTION™ device with 1kV DC galvanic isolation between the motor drive system (hot side) and the PC/debugger (cold side). The on-board debugger uses the SEGGER J-Link driver for UART communication with IMC301A-F064. The J-Link driver will be installed during the MCEDesigner installation. In case the driver is not installed properly, please go to [SEGGER J-Link website](#) to download and install the latest J-Link “Software and Documentation pack for Windows.”

### 5.2.1 MCEWizard setup overview

After installing the MCEWizard, please read the MCEWizard user guide first. Figure 6 shows the welcome page of MCEWizard.

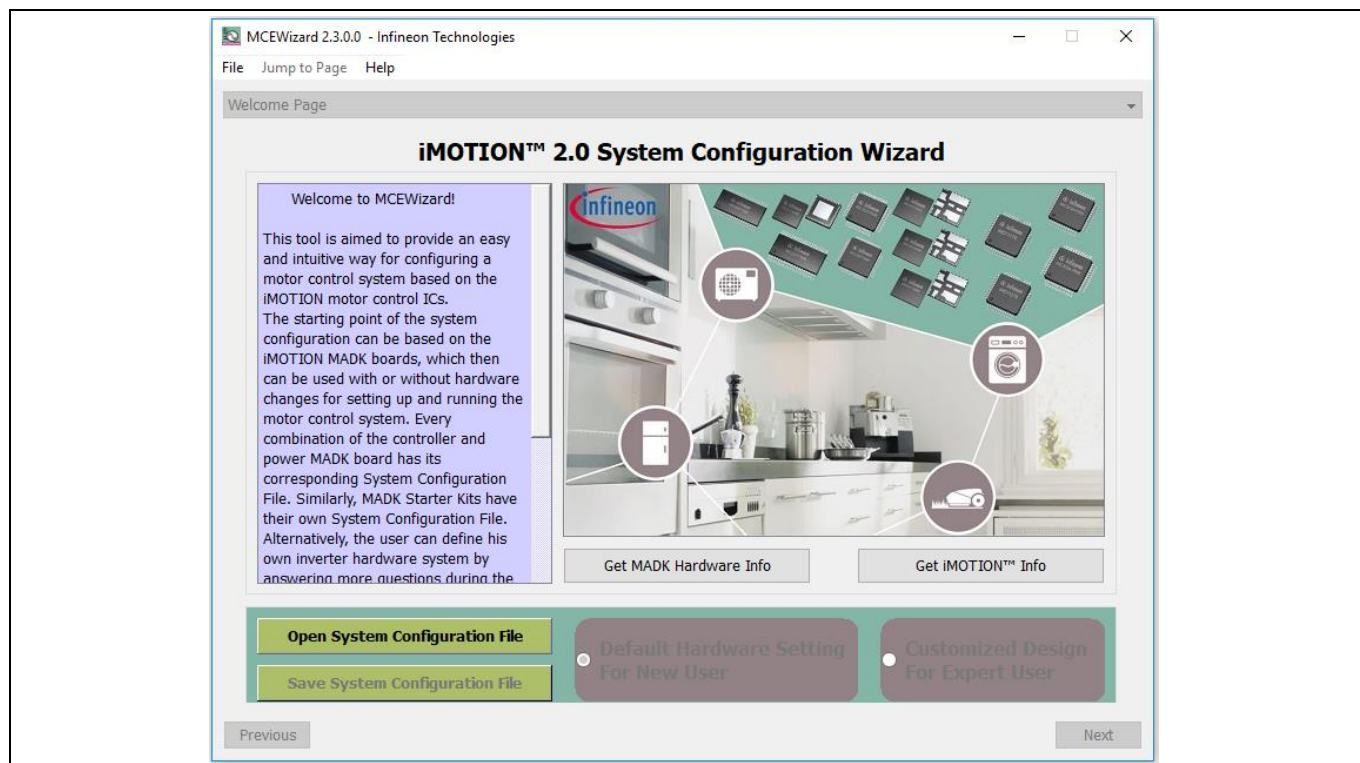

**Figure 6** Welcome page of MCEWizard

For new users, it is suggested to use this evaluation board with a released MADK power board, as they will always have a tested parameter file available on the MADK website. The default power board in this user guide is EVAL-M1-05-65D as shown in Figure 7.

iMOTION™ MADK system enables users to easily test different combinations of control and power boards with their motors. User should be familiar with the system-level parameters related to the motor used. There are a very limited number of parameters that are specific to the control board or power board hardware. Table 12 provides the MCEWizard setup overview for hardware-related parameters. Similar tables will be available in each power board’s user guide. A combination of this table and the corresponding table of the power board provides enough information to set up the MADK-based motor drive system in the shortest time.

**Table 12 MCEWizard setup overview table**

<b>Parameter</b>	<b>Value</b>	<b>Comment</b>
Power board selecting	MADK power board name	If no, select similar power board to modify
Motor 1 shunt configuration	Refer to the power board App Note	
Controller supply voltage	Refer to the power board App Note	VDD is 3.3V by default
Max DC bus voltage	Refer to the power board App Note	
DC bus sensing high resistor	Refer to the power board App Note	
DC bus sensing low resistor	13.3 kΩ	
NTC temperature shutdown value	Calculated as in Section 6.2.2	Refer to the power board App Note
GateSense low-side devices	Refer to the power board App Note	High is true by default
GateSense high-side devices	Refer to the power board App Note	High is true by default
Motor 1 current input	Calculated as in Section 6.1.2	

To start the MCEWizard system setup procedure, click the “Next” button in the right bottom corner as shown in Figure 7.

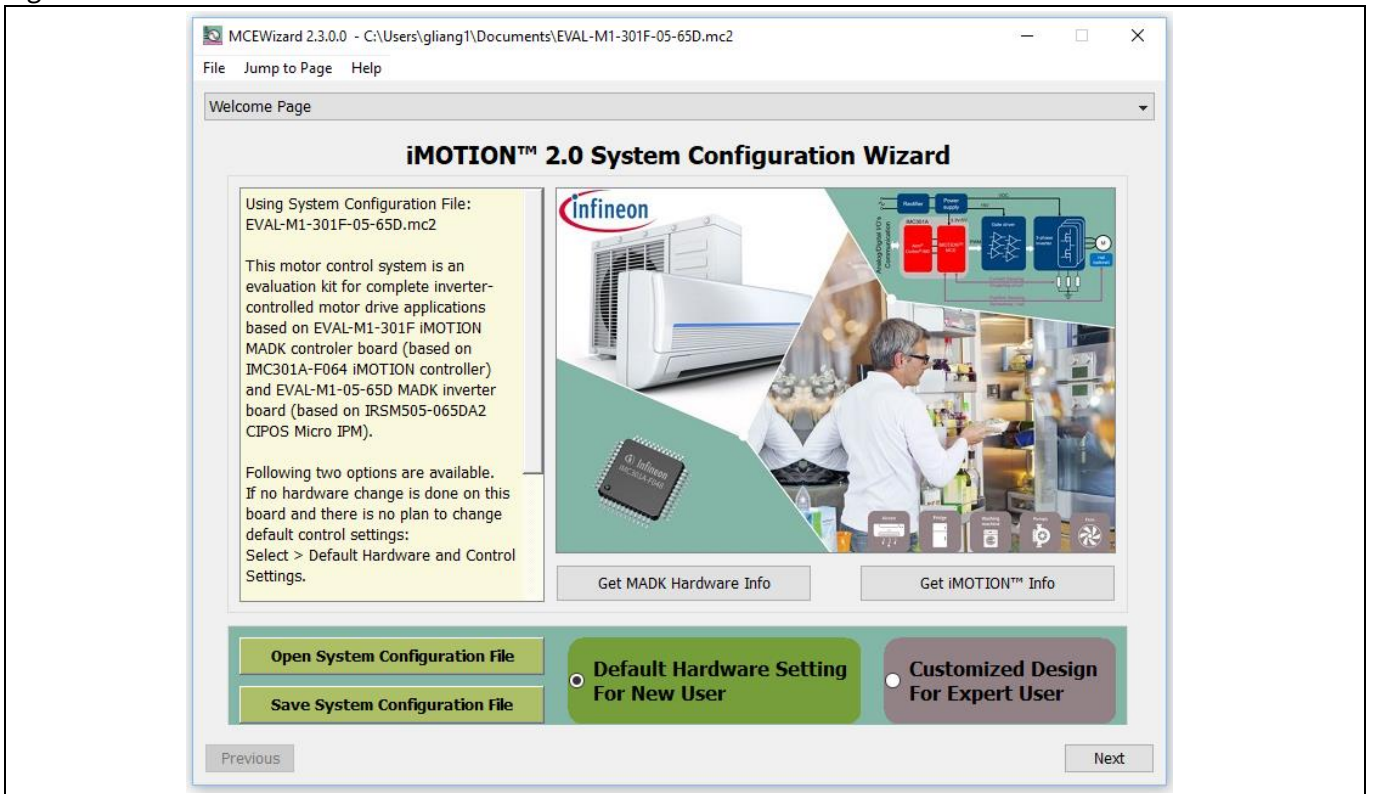

**Figure 7** Opening the default configuration file of this board

After all the MCEWizard questions have been answered, the “Verify & Save Page” will be shown as in Figure 8.

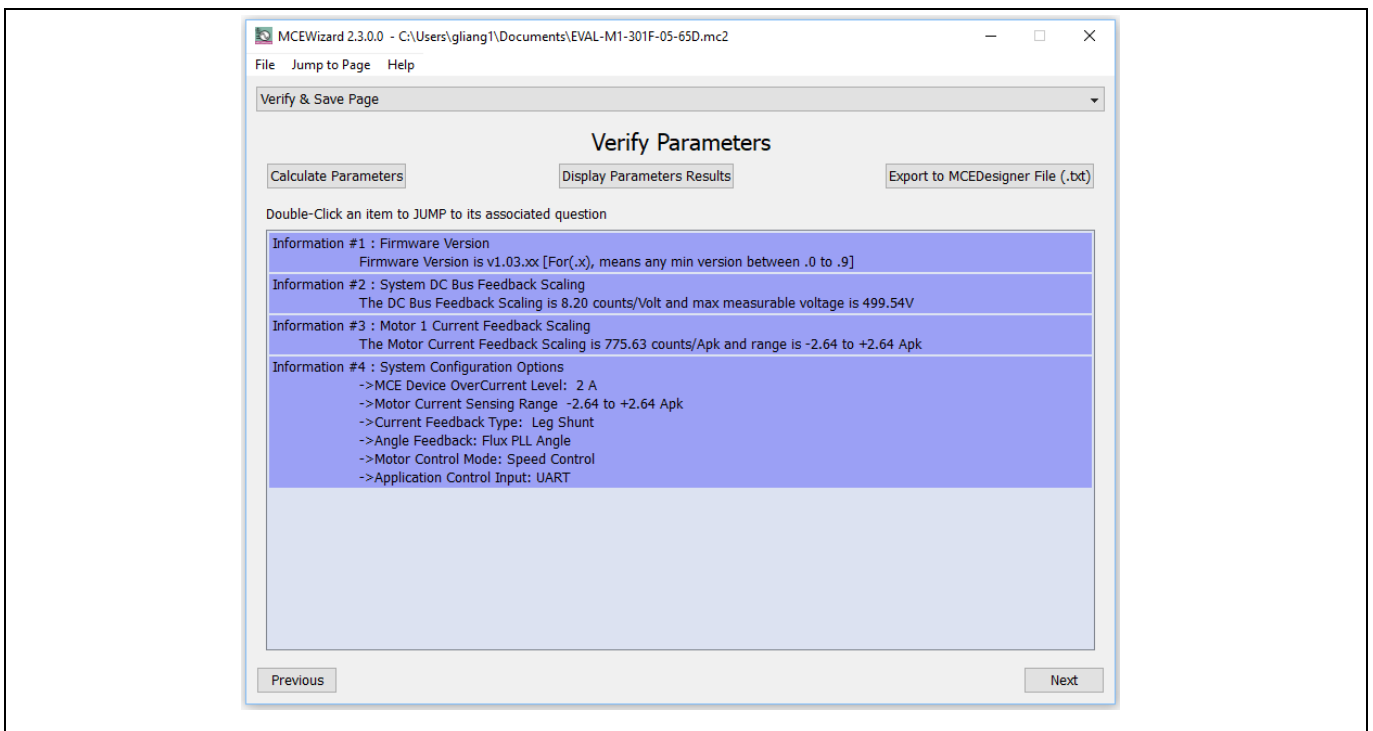
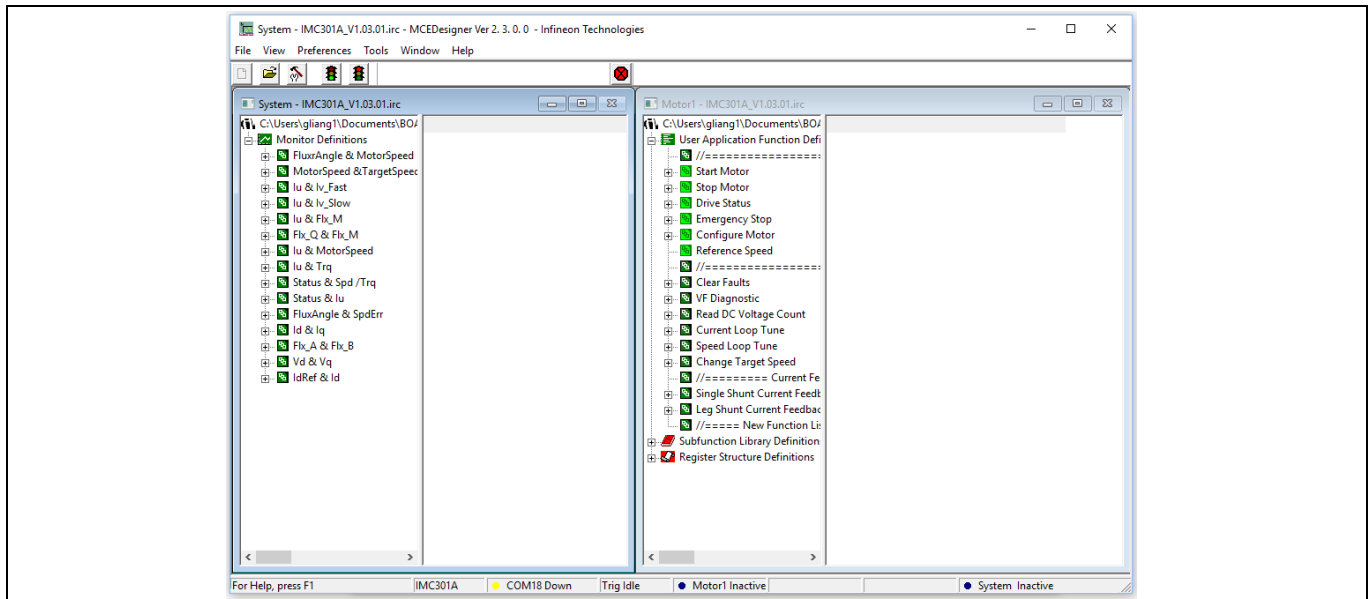

**Figure 8** Verify and Save page for MCEWizard

Click “Calculate Parameters” button and “Export to Designer File (.txt)” button to save the parameter file that will be used by the MCEDesigner in the next steps.

## 5.2.2 MCEDesigner setup overview

After installing the MCEDesigner installer, there is a shortcut for MCEDesigner on the Windows desktop. Double-click on the shortcut to open MCEDesigner and then open “IMC301A\_xx.irc” file (which was included in the “IMC301A-F064 MCE Software Package” installed earlier, as instructed in Chapter 0) shown in Figure 9.



**Figure 9 MCEDesigner’s main display for EVAL-M1-301F**

MCEDesigner programmer function can be used to program IMC301A-F064 firmware and/or system parameters. To call up this function, click on “Tools” menu and then select “Programmer” in the pull-down list. The pop-up window “Program IMC controller” will show up as in Figure 10.

To program both firmware and drive system parameters into IMC301A-F064 (which can happen when programming the brand new devices with default factory settings for the first time, or when the new version of iMOTION™ firmware is being downloaded), first click on the “Program Firmware and Parameter” radio button in the “Program IMC controller” pop-up window. After that, select the “Drive System Parameter” file created using MCEWizard by clicking on the “Browse...” button at the end of the “Program Parameter File” row, and then also select the IMC301A-F064\_A\_Vxxx.ldf file (which was included in the “IMC301A-F064 MCE Software Package”) by clicking on the “Browse...” button at the end of “Program Firmware File” row. Finally, click on the “Start” button to program the parameter file into the IMC301A-F064 IC.

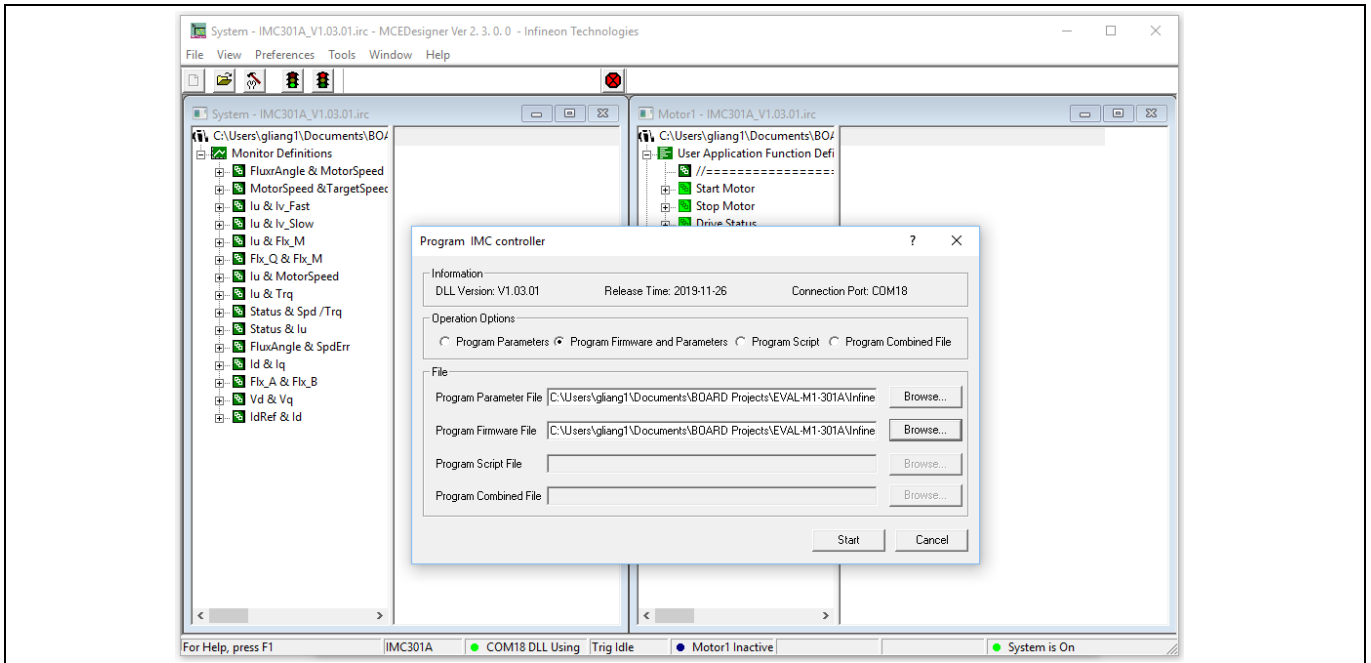

**Figure 10** Program firmware and parameters in “Program IMC Controller” pop-up window

To program only “Drive System Parameter” file into IMC301A-F064, click on “Tools” menu and select “Programmer” in the pull-down list. The pop-up window “Program IMC controller” will show up as in Figure 11. Click on the “Program Parameters” button (this is the default option), and then select the “Drive System Parameter” file created using MCEWizard by clicking on “Browse...”. Finally, click on the “Start” button to program the parameter file into the IMC301A-F064 IC.

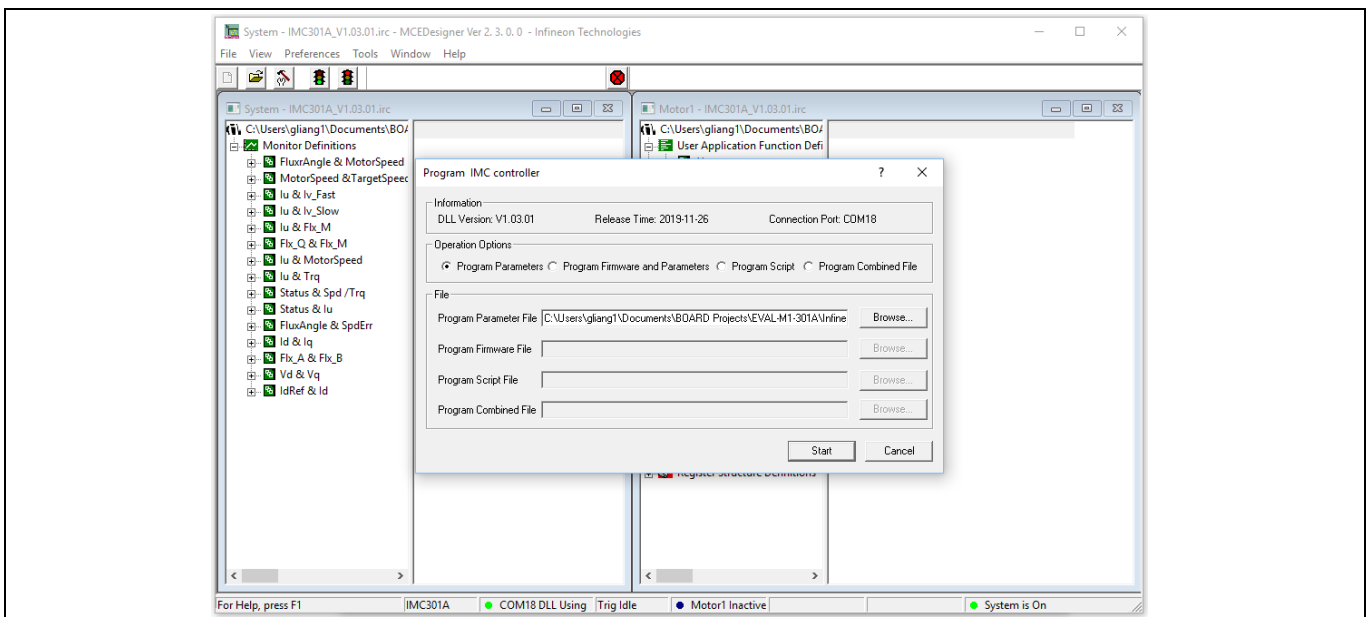

**Figure 11** “Program IMC Controller” pop-up window

After “Drive System Parameter” file has been programmed into IMC301A controller, and the motor drive system is powered, the MCEDesigner can be used to start/stop the motor, display motor current traces, change the



motor speed, modify drive parameters, and many other functions. Please refer to the MCEDesigner documentation for more details.

*Note: The on-board debugger section of EVAL-M1-301F is galvanically isolated from the controller section and the attached power board. In order to program the parameters or firmware to the IMC301A-F064 controller, the 3.3 V DC voltage needs to be supplied to the controller portion of the EVAL-M1-301F. This voltage can either be supplied by the power board (MADK power boards are designed to supply the 3.3 V to the control board through M1 or M3 connector) or by feeding the 3.3 V DC voltage to the control board through some of the available 3.3 V access/test points, if the power board is not attached to the EVAL-M1-301F control board.*

All the latest firmware files for different types of iMOTION™ control ICs are available for download via Infineon iMOTION™ website (<http://www.infineon.com/imotion-software>).

### **5.3 Working with the MCU**

The microcontroller in the IMC301A-F064 is based on an Arm® Cortex® M0 core allowing the use of a wide range of development tools and available software solutions.

Connection to the MCU is offered via the standard serial wire debug (SWD). The SWD interface is routed via the galvanic isolation to the on-board interface. The debug interface is based on Segger® J-Link technology. The respective DLL is installed on the PC during installation of the above-mentioned iMOTION tools, namely the MCEDesigner. Alternatively, the installation of the respective driver can be updated from the Segger website.

Configuring, setting up and programming the embedded MCU is beyond the scope of this user guide. Please refer to the Hardware Reference Manual of the IMC300 series and the CMSIS pack.



## 6 Hardware description of EVAL-M1-301F

This chapter covers the hardware design of the EVAL-M1-301F in more detail. To enable users to make the EVAL-M1-301F evaluation board a basis for a new development or modification of their own systems, all necessary technical data such as schematics, layout and components are also included in this chapter.

### 6.1 Motor current feedback circuitry

#### 6.1.1 Motor shunt configuration

Both single shunt and leg shunt topologies are supported by the EVAL-M1-301F control board. The user needs to ensure that the shunt configuration matches with the power board hardware configuration. Please refer to the power board user guide for details. The shunt configuration can be changed in the option page as shown in Figure 12.

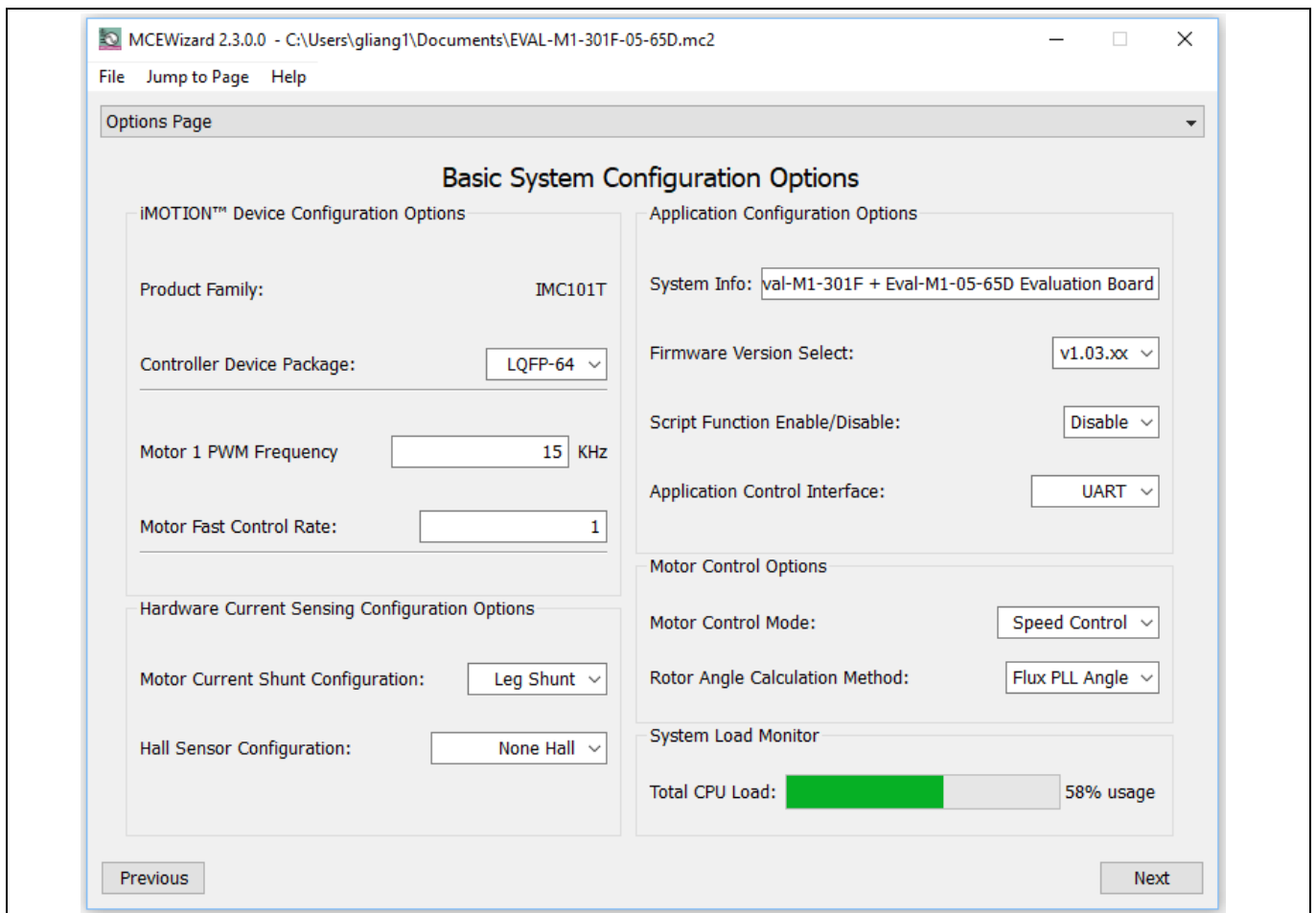
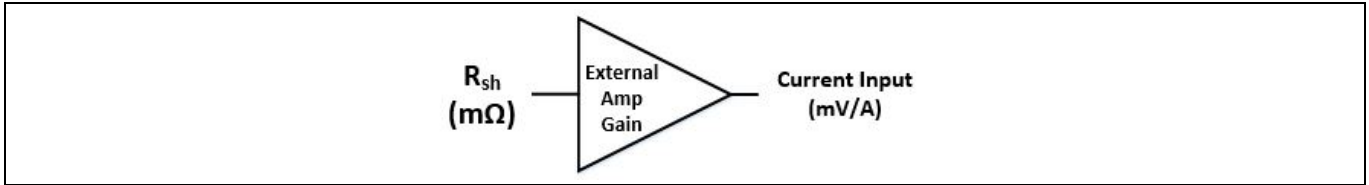

**Figure 12 Shunt configuration**

#### 6.1.2 Motor external current feedback configuration and calculation

The shunt resistance  $R_{sh}$  value can be found in the schematics or user guide for the power board (for example, the leg shunt resistors are 30 mΩ for EVAL-M1-05-065D).

The current input value is a product of the shunt resistance in milliohms and gain of external current sense amplifier as shown in Figure 13.



**Figure 13** Current shunt feedback and sample timing

Figure 14 depicts IU+ current feedback sensing circuitry on EVAL-M1-301F evaluation board. Please note that the default external amplification gain is less than 1 for current sense in this evaluation board.

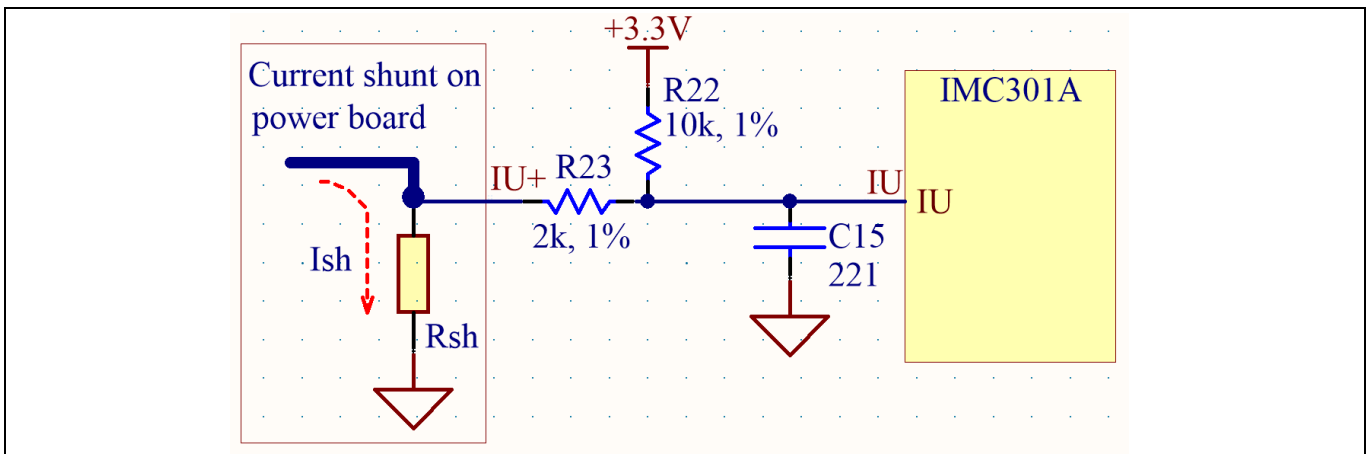

**Figure 14** The current feedback section on the EVAL-M1-301F evaluation board

Based on the principle of Kirchhoff's voltage law,

$$V_{IU} = (V_{DD} - I_{sh} * R_{sh}) * \frac{R_{23}}{R_{22} + R_{23}} + I_{sh} * R_{sh} = \frac{R_{23}}{R_{22} + R_{23}} V_{DD} + \frac{R_{22}}{R_{22} + R_{23}} R_{sh} * I_{sh}$$

$$Current\ input = \frac{R_{22}}{R_{22} + R_{23}} R_{sh} = \frac{5}{6} R_{sh}$$

R<sub>sh</sub> in EVAL-M1-05-065D is 250 mΩ, based on this calculation, the current input for the MADK combination of EVAL-M1-301F and EVAL-M1-05-065D is 208.3 mV/A. Please use the same procedure to calculate the current input for other combinations of MADK boards and enter it into MCEWizard.

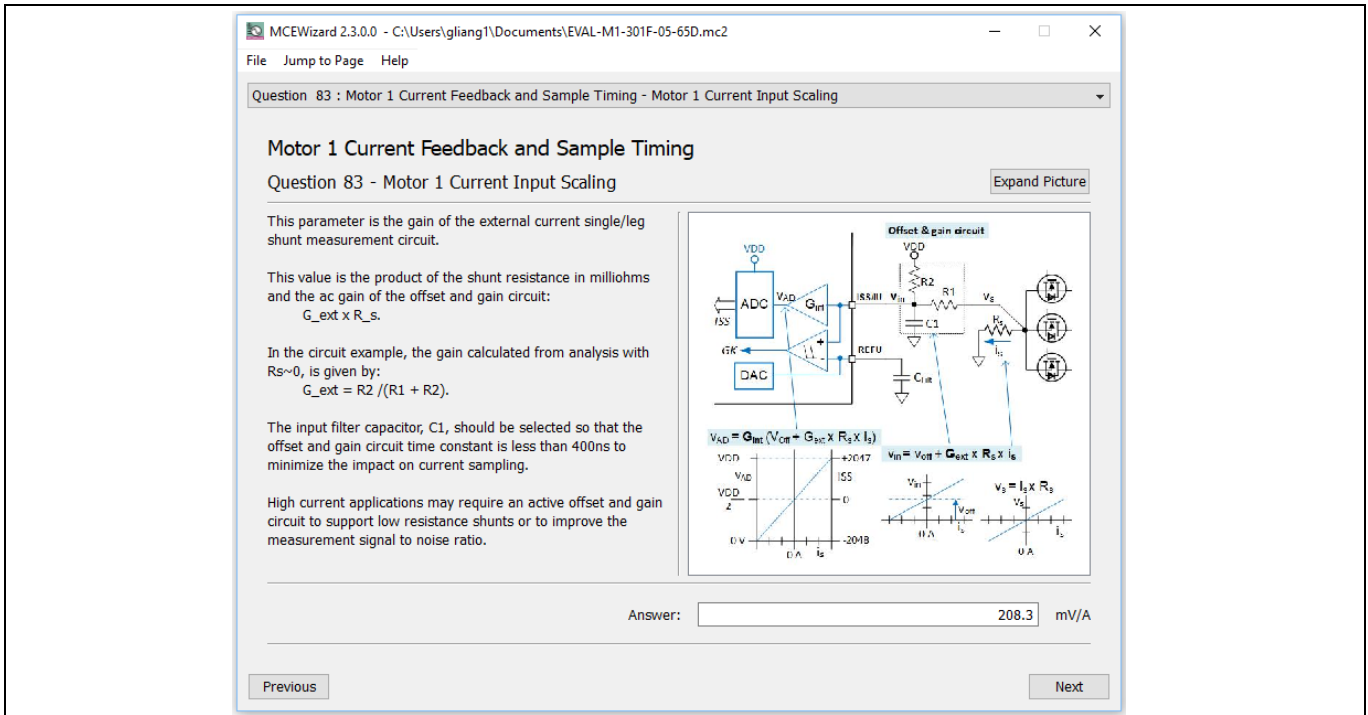
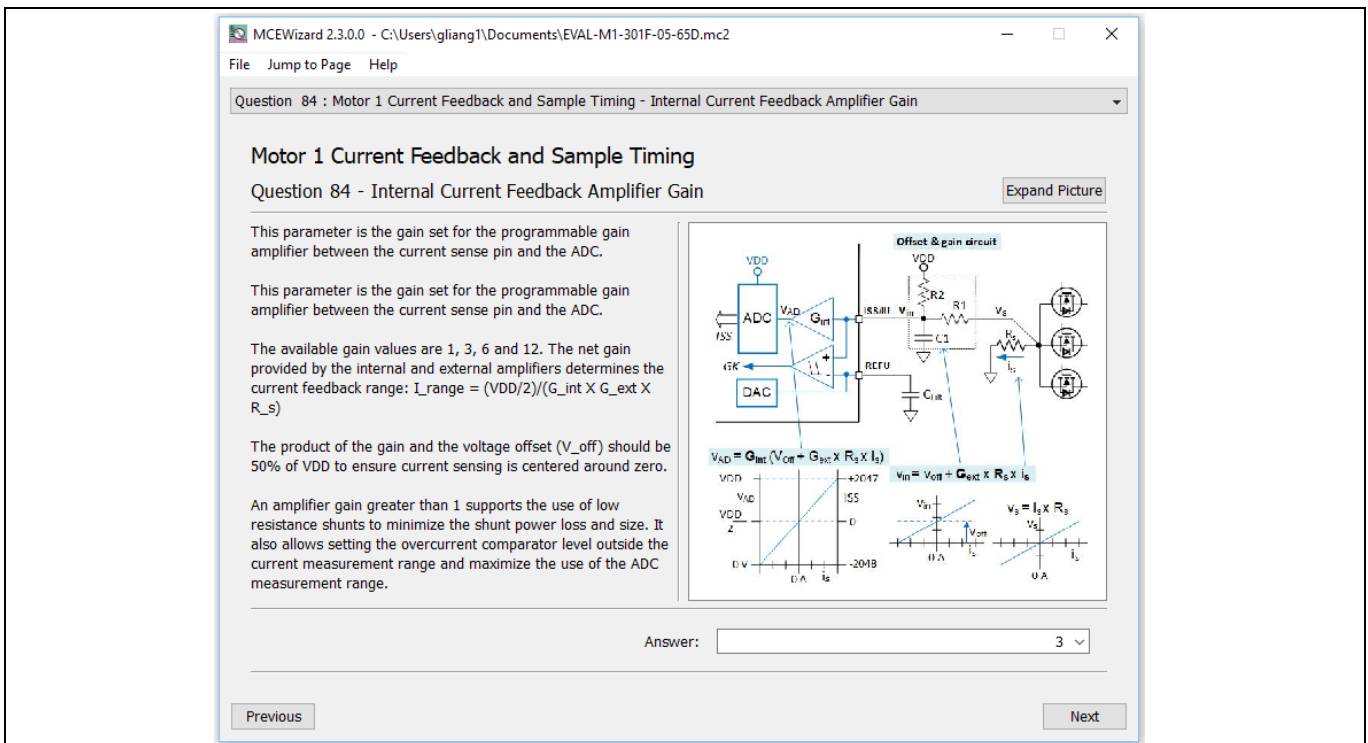

**Figure 15 Current feedback configuration in MCEWizard for EVAL-M1-301F and EVAL-M1-05-065D**

### 6.1.3 Amplifier-gain configuration

For the current feedback, the iMOTION™ controller on this board has an internal amplifier, which has four programmable gain settings: 1x, 3x, 6x and 12x.

The internal current-feedback amplifier gain can be configured in MCEWizard as shown in Figure 16.



**Figure 16 Internal current-feedback amplifier-gain configuration**

## 6.2 EVAL-M1-301F analog inputs and their MCEWizard setup

Besides current-sensing inputs, IMC301A-F064 provides a number of analog inputs for different system functions. Figure 17 depicts the analog inputs of the IMC301A-F064 except for the current-sensing inputs.

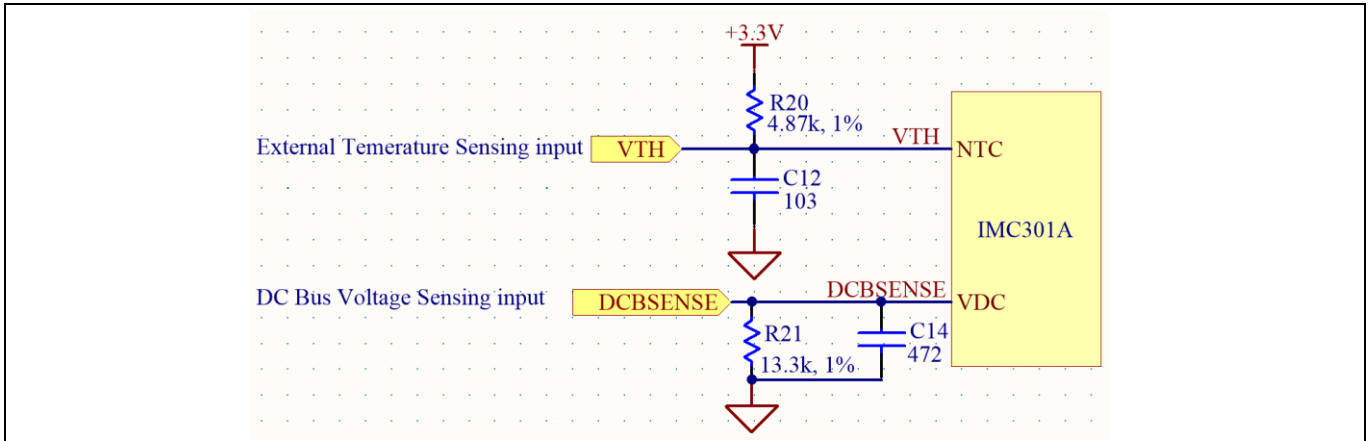

**Figure 17** Analog inputs on the EVAL-M1-301F evaluation board

### 6.2.1 DC bus sensing configuration

The low-side resistor R4 for the DC bus sensing resistor divider on the controller board EVAL-M1-301F is 13.3 kΩ, and should be configured in MCEWizard as shown in Figure 18. For the high-side resistor value, please refer to the user guide of the corresponding power board.

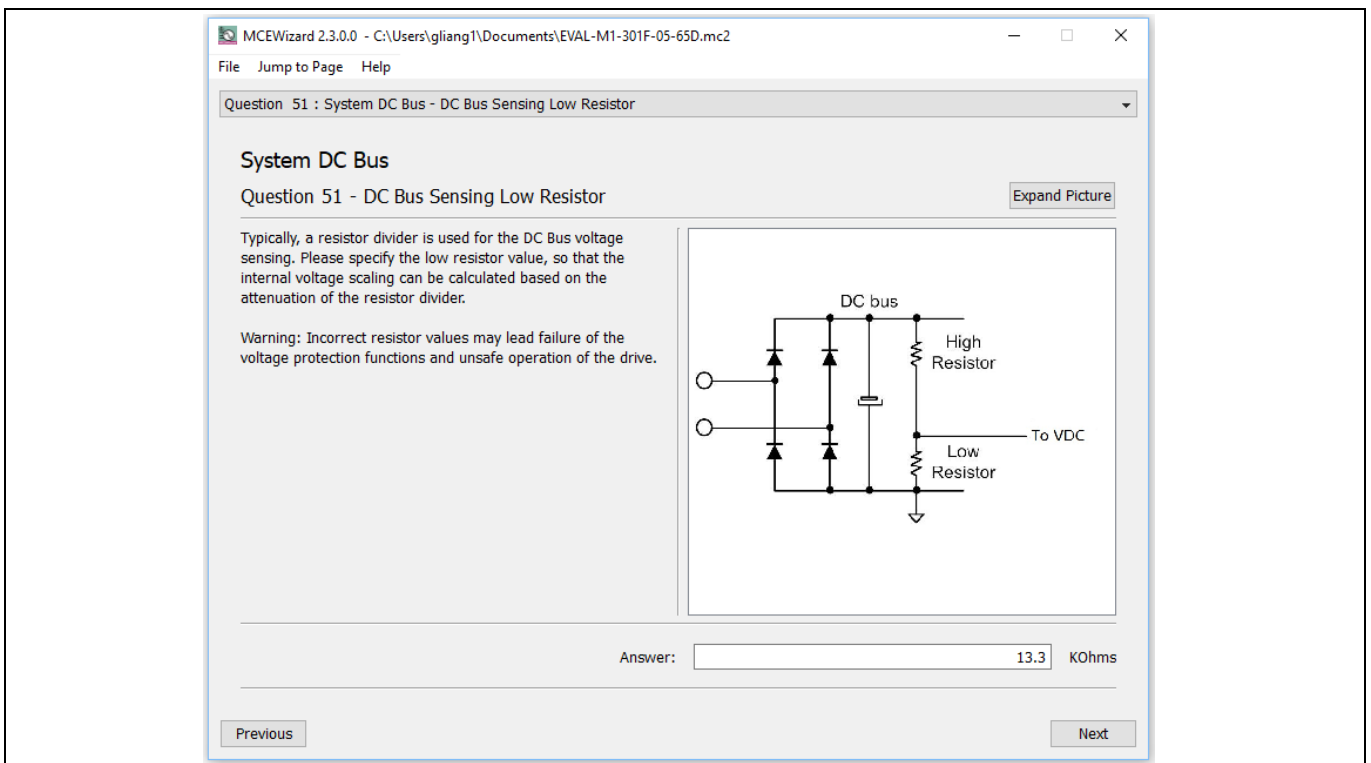

**Figure 18** DC bus-sensing configuration in MCEWizard

## 6.2.2 NTC shutdown value calculation and configuration

External NTC temperature shutdown values can be calculated as shown below and configured in MCEWizard as shown in Figure 19. For the pull-up resistor on the evaluation power board and the NTC value, please refer to the power board's user guide. The value of the pull-up resistor on EVAL-M1-301F is 4.87 kΩ (see Figure 17).

$$R_{total\ pull-up} = \frac{R_{pull-up\ on\ Control\ board} * R_{pull-up\ on\ Power\ board}}{R_{pull-up\ on\ Control\ board} + R_{pull-up\ on\ Power\ board}}$$

$$V_{shut\ down} = \frac{R_{NTC@setting\ temperature}}{R_{NTC@setting\ temperature} + R_{total\ pull-up}} V_{DD}$$

The typical value of  $R_{NTC}$  at 100°C is 2.9 kΩ for the IPM IRSM505-065DA that is used in EVAL-M1-05-065D and no pull-up resistor is connected. If the setting temperature is 100°C, the shutdown value should be 1.24 V.

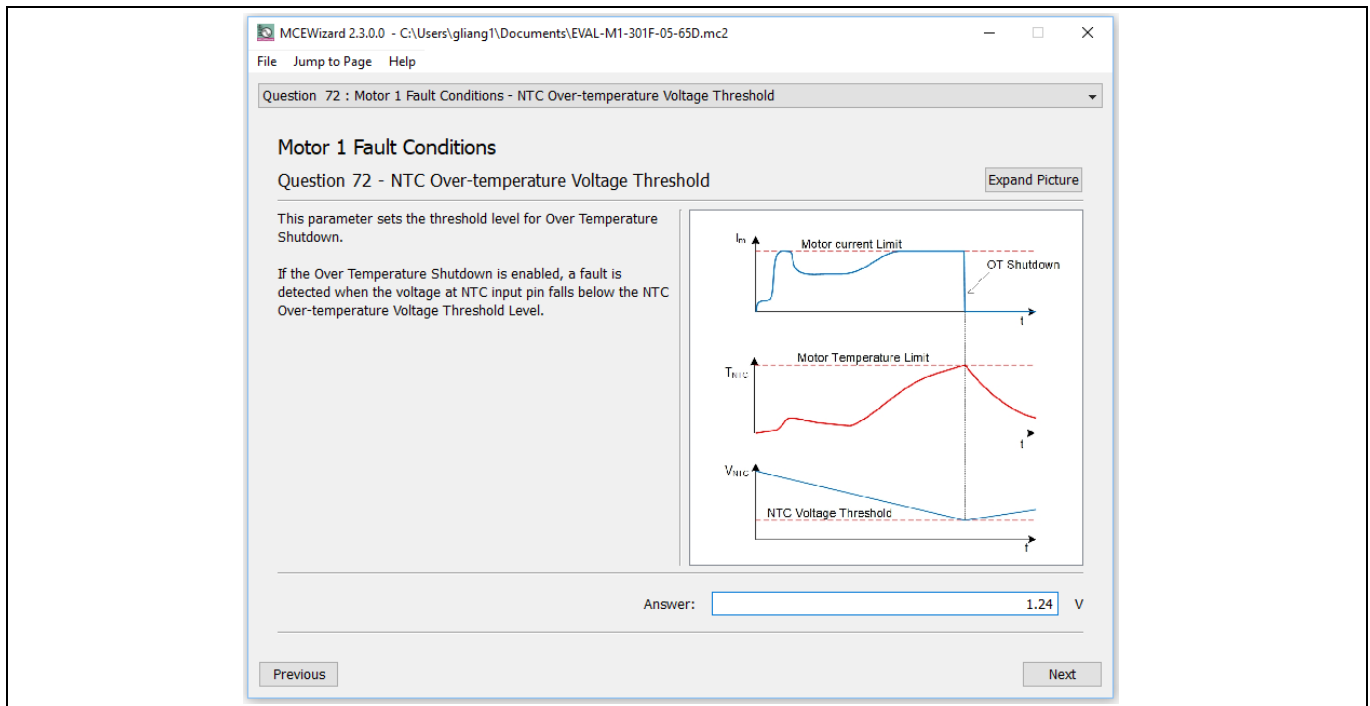

**Figure 19 External temperature-sensing input configuration in MCEWizard**

### 6.3 Schematics overview

Figure 20 shows the schematics of EVAL-M1-301F evaluation board with IMC301A-F064 controller.

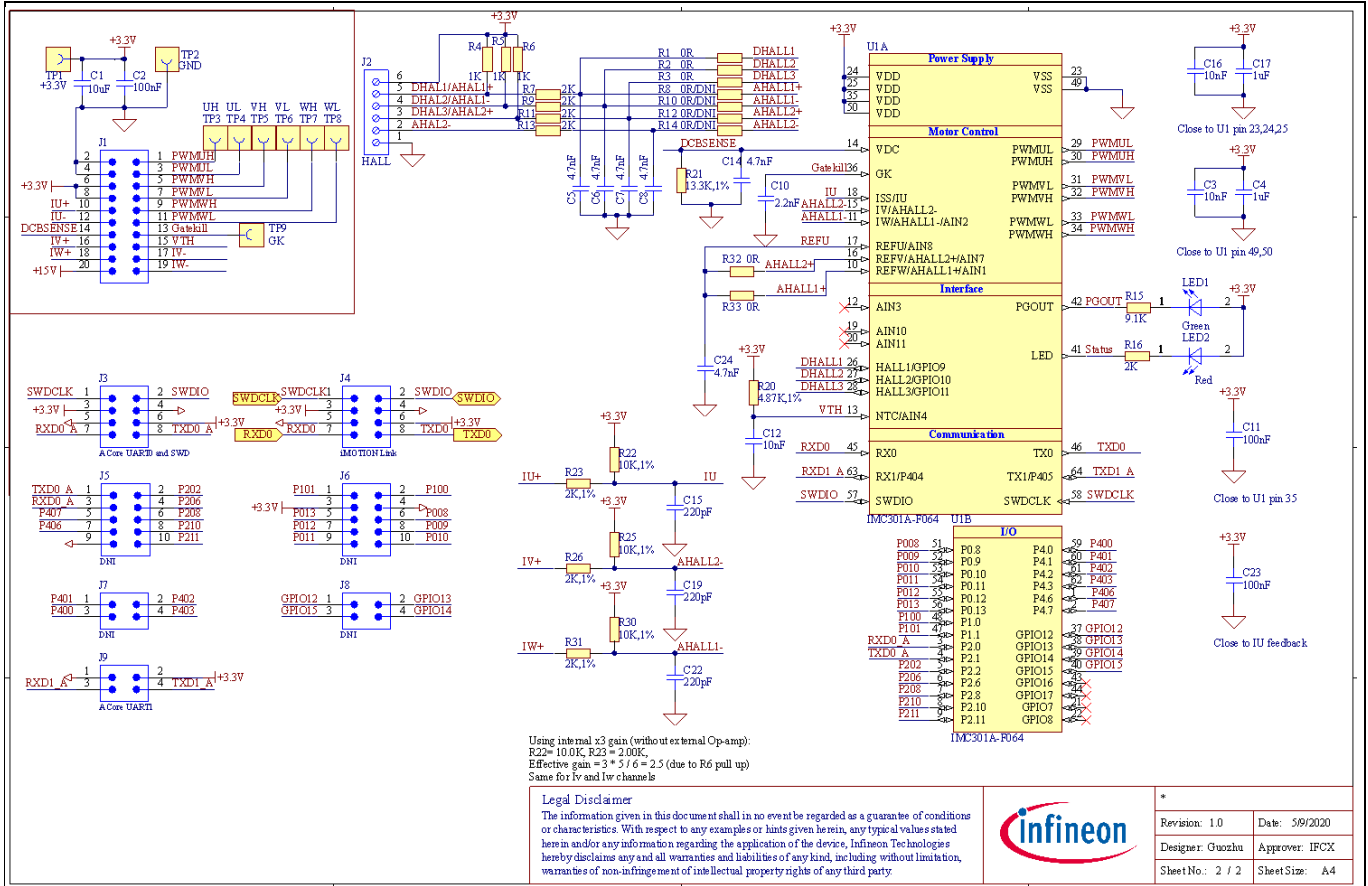

**Figure 20** The schematics of the EVAL-M1-301F evaluation board

### 6.4 PCB layout overview

The layout of this board can be used for different voltages or power classes of the power board. The PCB has two electrical layers with 35 μm copper by default, and its size is 65 mm × 45 mm. The PCB board thickness is 1.6 mm. Check Infineon’s website or get in contact with Infineon’s technical support team to obtain more detailed information and the latest Gerber files.

Figure 21 illustrates the top assembly print and top paste layers of the evaluation board.



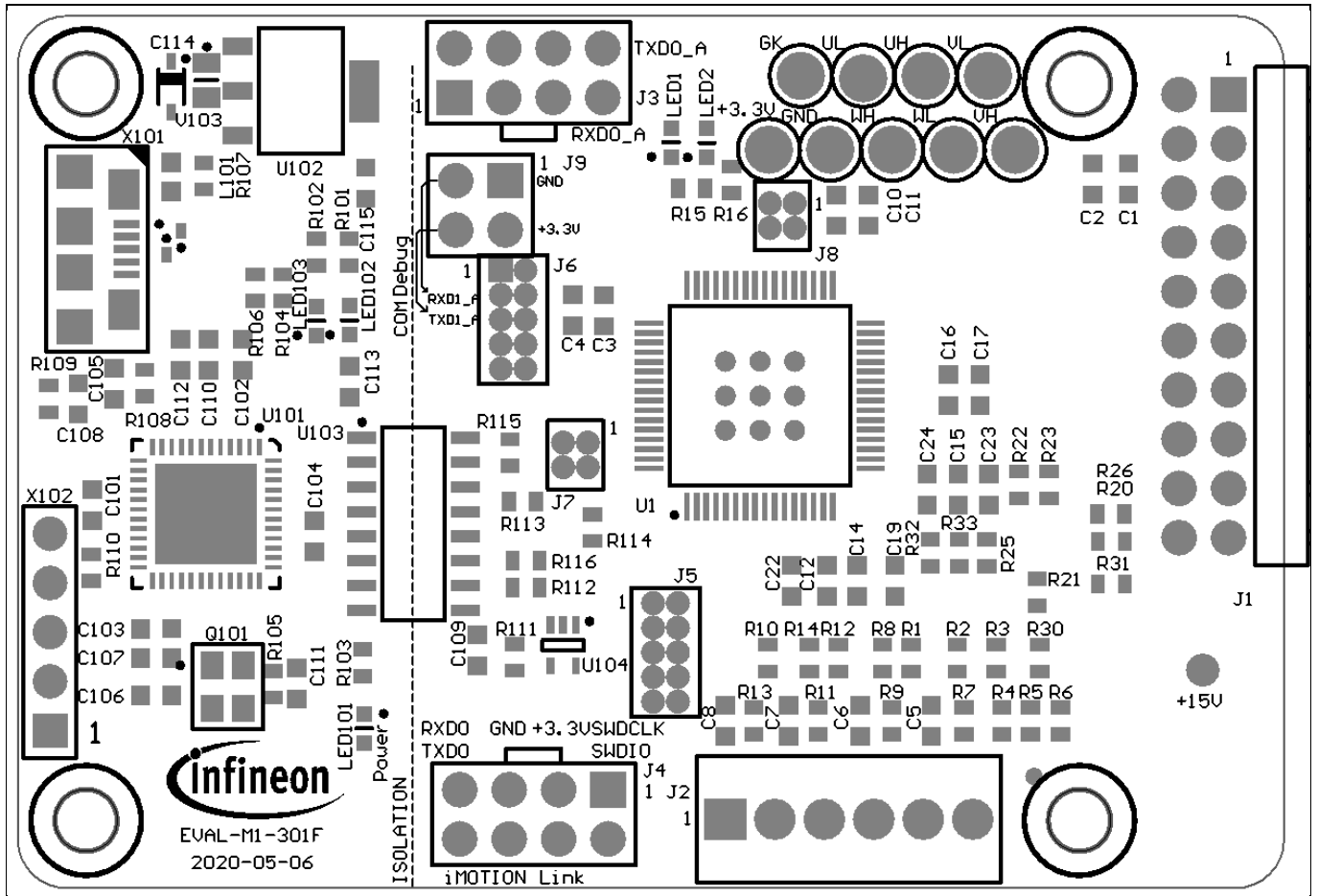

**Figure 21 Top overlay print of the EVAL-M1-301F evaluation board**

Figure 22 depicts the bottom assembly print of the evaluation board.

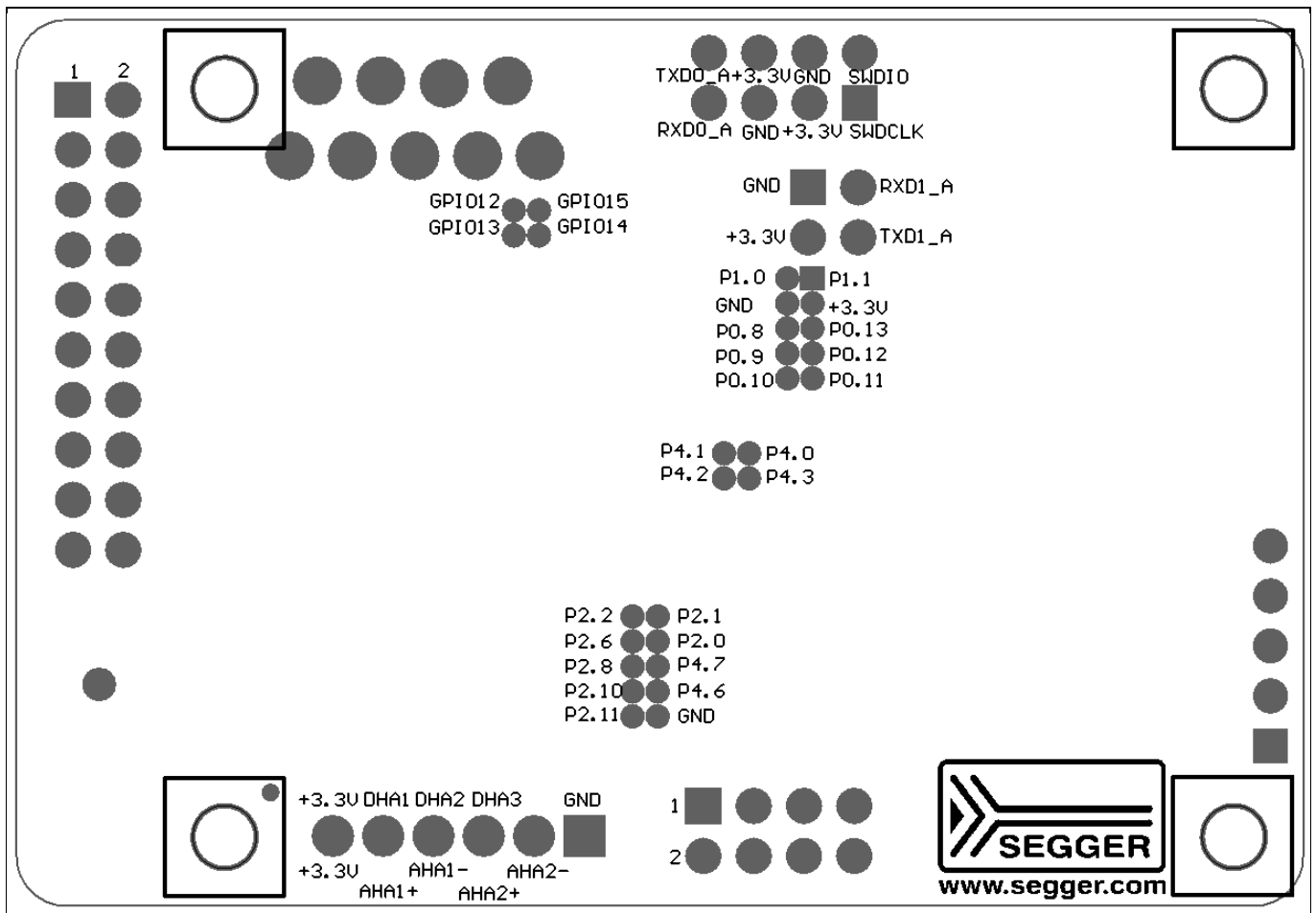

**Figure 22 Bottom overlay print of the EVAL-M1-301F evaluation board**

The top layer routing of the PCB is provided in the following Figure 23.

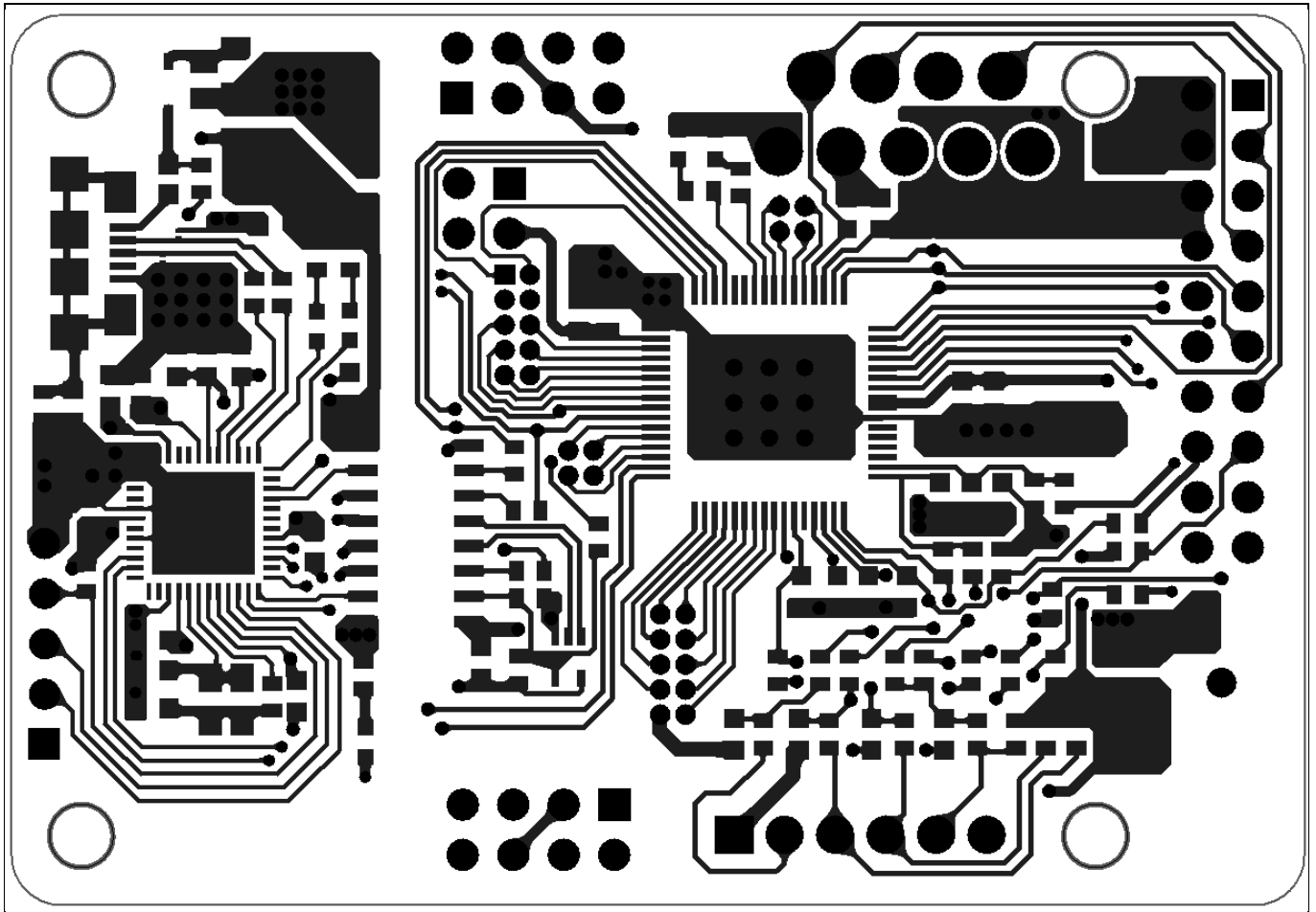

**Figure 23 Top layer routing of the EVAL-M1-301F**

Figure 24 illustrates the bottom layer routing of the PCB.

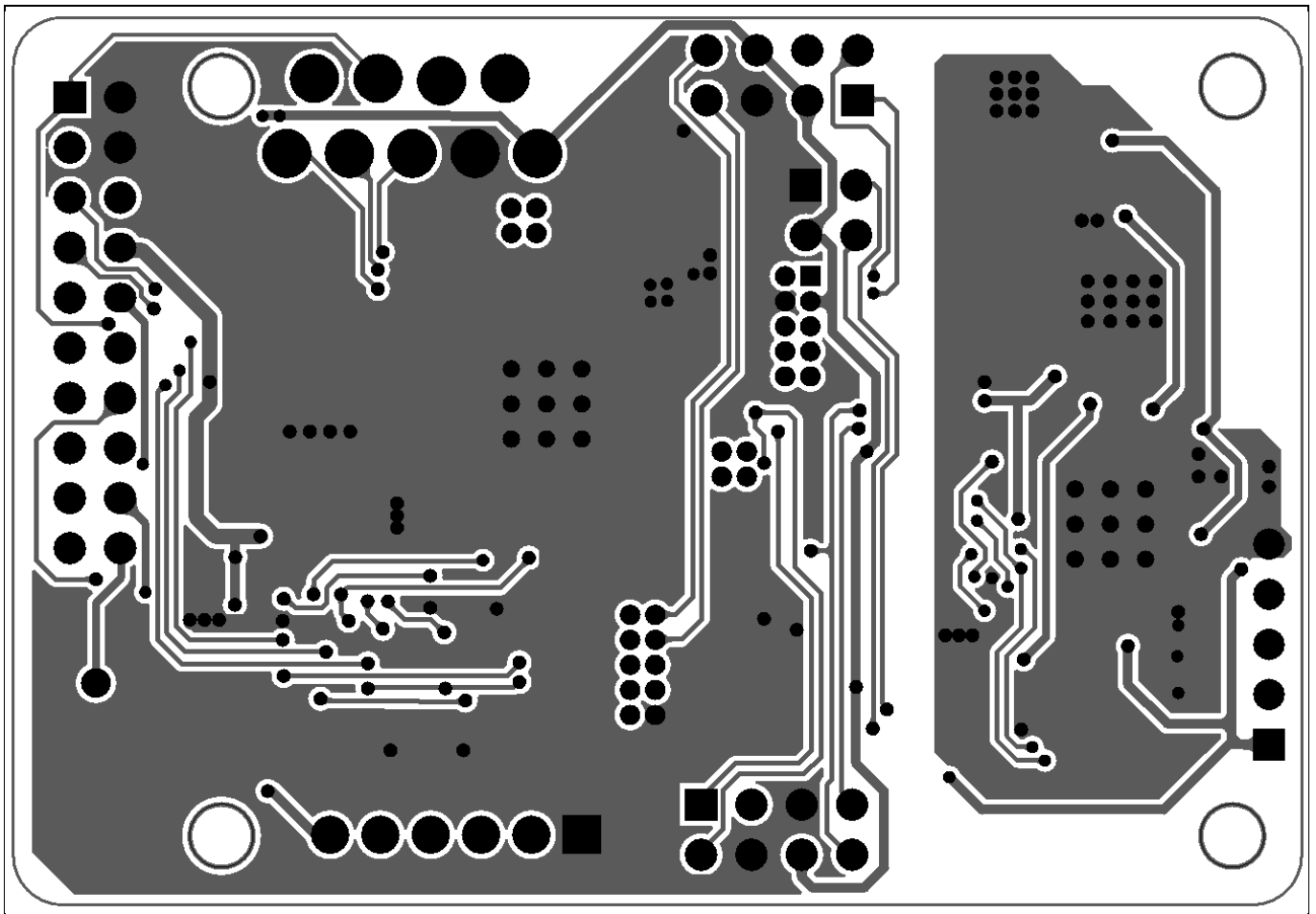

**Figure 24** Bottom layer routing of the EVAL-M1-301F

**Bill of materials**

## 7 Bill of materials

Table 13 provides the complete bill of materials for the EVAL-M1-301F board.

**Table 13 Bill of materials**

No.	Qty.	Part description	Designator	Part Number	Manufacturer
1	3	10uF / 6.3V / 20% / X5R (EIA) / CAPC1608X90N	C1, C105, C115	GRM188R60J106ME84	
2	10	100nF / 16V / 5% / X7R (EIA) / CAPC1608X90N	C2, C11, C23, C101, C102, C103, C104, C108, C110, C111	GRM188R71C104JA01	
3	3	10nF / 16V / 5% / X7R (EIA) / CAPC1608X90N	C3, C12, C16	GRM188R71C103JA01	
4	4	1uF / 16V / 10% / X5R (EIA) / CAPC1608X90N	C4, C17, C109, C113	GRM188R61C105KA12	
5	6	4.7nF / 16V / 10% / X7R (EIA) / CAPC1608X90N	C5, C6, C7, C8, C14, C24	GRM188R71C472KA01	
6	1	2.2nF / 50V / 5% / COG (EIA) / NPO / CAPC1608X90N	C10	GRM1885C1H222JA01	
7	3	220pF / 50V / 2% / COG (EIA) / NPO / CAPC1608X90N	C15, C19, C22	GRM1885C1H221GA01	
8	2	15pF / 50V / 2% / COG (EIA) / NPO / CAPC1608X90N	C106, C107	GRM1885C1H150GA01	
9	1	4.7uF / 16V / 10% / X5R (EIA) / CAPC1608X90N	C112	GRM188R61C475KAAJ	
10	1	10uF / 10V / 10% / X5R (EIA) / CAPC2013X95N	C114	GRM219R61A106KE44	
11	1	WR-PHD Pin Header, THT, pitch 2.54mm, Dual Row, Angled, 20pin	J1	61302021021	Würth Elektronik
12	1	WR-TBL Serie 2109 Horizontal Entry, Rising Cage Clamp, pitch 2.54mm, 6p	J2	691210910006	Würth Elektronik
13	2	WR-PHD Pin Header, THT, pitch 2.54mm, Dual Row, Vertical, 8pin	J3, J4	61300821121	Würth Elektronik
14	2	WR-PHD Pin Header, THT, pitch 1.27mm, Dual Row, Vertical, 10pin	J5, J6	62201021121	Würth Elektronik
15	2	WR-PHD Pin Header, THT, pitch 1.27mm, Dual Row, Vertical, 4pin	J7, J8	62200421121	Würth Elektronik

**Bill of materials**

No.	Qty.	Part description	Designator	Part Number	Manufacturer
16	1	WR-PHD Pin Header, THT, pitch 2.54mm, Dual Row, Vertical, 4pin	J9	61300421121	Wurth Elektronik
17	1	60R / Ferrite Bead / SMD Chip	L101	BLM18PG600SN1	
18	2	LED / 0603	LED1, LED102	LG L29K-G2J1-24	
19	2	LED / 0603	LED2, LED101	LS L29K-H1J2-1	
20	1	LED / 0603	LED103	LS L29K-H1J2-1	
21	1	12.000MHz, 100ohm, 10uW, 8pF. Crystal	Q101	NX3225GA-12.000M-STD-CRG-2	
22	9	0R / 0R / 0603	R1, R2, R3, R32, R33, R113, R114, R115, R116	CRCW06030000Z0	
23	3	1k / 1% / 0.10 / 0603	R4, R5, R6	CRCW06031K00FK	
24	6	2k / 1% / 0.10 / 0603	R7, R9, R11, R13, R16, R103	CRCW06032K00FK	
25	4	0R / 0R / 0603	R8, R10, R12, R14	CRCW06030000Z0	
26	2	9.1k / 1% / 0.10 / 0603	R15, R101	CRCW06039K10FK	
27	1	4.87k / 1% / 0.10 / 0603	R20	CRCW06034K87FK	
28	1	13.3k / 1% / 0.10 / 0603	R21	CRCW060313K3FK	
29	3	10k / 1% / 0.10 / 0603	R22, R25, R30	CRCW060310K0FK	
30	3	2k / 1% / 0.10 / 0603	R23, R26, R31	CRCW06032K00FK	
31	1	3k / 1% / 0.10 / 0603	R102	CRCW06033K00FK	
32	2	33R / 1% / 0.10 / 0603	R104, R106	CRCW060333R0FK	
33	1	510R / 1% / 0.10 / 0603	R105	CRCW0603510RFK	
34	2	4.7k / 1% / 0.10 / 0603	R107, R111	CRCW06034K70FK	
35	2	10k / 1% / 0.10 / 0603	R108, R110	CRCW060310K0FK	
36	1	1MEG / 1% / 0.10 / 0603	R109	CRCW06031M00FK	
37	1	0R / 0R / 0603	R112	CRCW06030000Z0	
38	4	M3 X 6mm Pan Head, Cross Head Metric Screw, 5.6mm X 2.4mm Head, Nylon 6,6	Screw1, Screw2, Screw3, Screw4	D00687	
39	4	Hex-Standoff / Female - Female M3 / 6 x 6 (DxH)	Standoff1, Standoff2, Standoff3, Standoff4	05.30.315	
40	9	None (onboard) / Board-to-Cable	TP1, TP2, ... , TP9	20-2136	

**Bill of materials**

<b>No.</b>	<b>Qty.</b>	<b>Part description</b>	<b>Designator</b>	<b>Part Number</b>	<b>Manufacturer</b>
41	1	High Performance motor control IC series	U1	IMC301A-F064	Infineon Technologies
42	1	3.63V - 3.13V / PG-VQFN-48-53	U101	XMC4200Q48K256ABX UMA1	Infineon Technologies
43	1	Linear / PG-SOT223-4	U102	IFX25001ME V33	Infineon Technologies
44	1	Low Power Six-Channel Digital Isolator	U103	SI8462BA-A-IS1	
45	1	Bus Buffer/Line Driver; 3-State	U104	74LVC1G126GW	
46	2	TVS Diode / PG-TSSLP-2-1	V101, V102	ESD237-B1-W0201	Infineon Technologies
47	1	Schottky Diode / SOD323	V103	BAS3010A-03W	Infineon Technologies
48	1	Micro-USB 2.0 Standard, Type AB, Bottom Mount, Shell SMT	X101	ZX62-AB-5PA(31)	
49	1	WR-PHD Pin Header, THT, pitch 2.54mm, Single Row, Vertical, 5pin	X102	61300511121	Wurth Elektronik



**Reference**

## **8 Reference**

- [1] IMC300 Series Datasheet
- [2] IMC300 Hardware Reference Manual
- [3] iMOTION™ MCE Software Reference Manual
- [4] MCEWizard User Guide
- [5] MCEDesigner User Guide
- [6] Interfacing with iMOTION™ products , Application Note

*Note:* All listed reference materials are available for download on Infineon's website [www.infineon.com/imotion](http://www.infineon.com/imotion). All User Guides of the iMOTION™ MADK power boards are available at [www.infineon.com/MADK](http://www.infineon.com/MADK)

### **Notice:**

Infineon's product registration is now online. You can register your board online, and download additional information.

There are three easy steps to register:

1. Go to [www.infineon.com](http://www.infineon.com)/ login to myinfineon
2. Click on "Product Registration"
3. Choose your board, and enter board series number, then download the related information package

## Revision history

Document version	Date of release	Description of changes
1.0	2020-06-08	First Release
1.1	2021-04-16	Update getting started, PC interface

**Trademarks**

All referenced product or service names and trademarks are the property of their respective owners.

**Edition 2021-04-16**

**Published by**

**Infineon Technologies AG**

**81726 Munich, Germany**

**© 2021 Infineon Technologies AG.**

**All Rights Reserved.**

**Do you have a question about this document?**

**Email: [erratum@infineon.com](mailto:erratum@infineon.com)**

**Document reference**

**UG-2020-13**

For further information on the product, technology, delivery terms and conditions and prices please contact your nearest Infineon Technologies office ([www.infineon.com](http://www.infineon.com)).

**WARNINGS**

Due to technical requirements products may contain dangerous substances. For information on the types in question please contact your nearest Infineon Technologies office.

Except as otherwise explicitly approved by Infineon Technologies in a written document signed by authorized representatives of Infineon Technologies, Infineon Technologies' products may not be used in any applications where a failure of the product or any consequences of the use thereof can reasonably be expected to result in personal injury.