

REF-SHA35WRC2SYS user guide

High voltage ceiling fan reference design

About this document

Scope and purpose

This user guide provides an overview of the reference board REF-SHA35WRC2SYS including its main features, key test results and mechanical dimensions.

The REF-SHA35WRC2SYS is a full-featured starter kit, with a turnkey motor driver designed for high-performance, high-efficiency permanent magnet synchronous motor (PMSM) / brushless direct current motor (BLDC) applications, including all the required elements for high voltage ceiling fan applications. It includes the iMOTION™ IMD112T driver for PFC and motor control, the 1ED44171N01B for PFC gate driver, IKA08N65H5 DuoPack IGBTs and diodes for PFC switching, and the TRENCHSTOP™ RC-Series IKN03N60RC2 that provides cost-effective, monolithically integrated IGBTs with diode for the inverter stage.

The starter kit features Infineon's iMOTION™ driver and advanced motion control engine (MCE 2.0) technology for PMSM/BLDC motor and PFC driver. It is optimized for small and major home appliances like fans, pumps, compressors, and other general-purpose variable speed drives.

Note: Please note that this product is not qualified according to the AEC Q100 or AEC Q101 documents from the Automotive Electronics Council.

Intended audience

This user guide is intended for all technical specialists who are familiar with ceiling fan control and electronics converters. The reference design is intended to be used under laboratory conditions only by trained specialists.

Reference board/kit

Product(s) embedded on a PCB, with a focus on specific applications and defined use cases that may include software. PCB and auxiliary circuits are optimized for the requirements of the target application.

Note: The boards do not necessarily meet the safety or quality standards requirements such as UL, CE.

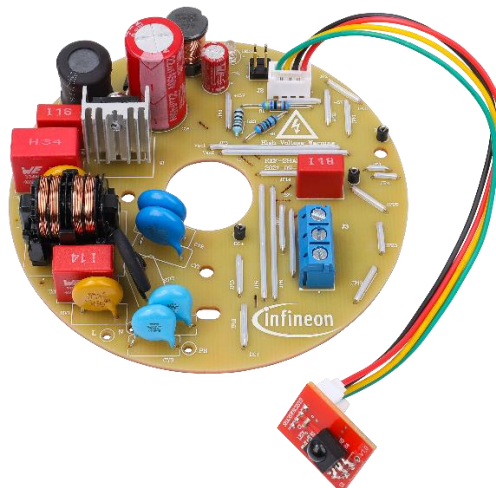

Important notice

Important notice

“Evaluation Boards and Reference Boards” shall mean products embedded on a printed circuit board (PCB) for demonstration and/or evaluation purposes, which include, without limitation, demonstration, reference and evaluation boards, kits and design (collectively referred to as “Reference Board”).

Environmental conditions have been considered in the design of the Evaluation Boards and Reference Boards provided by Infineon Technologies. The design of the Evaluation Boards and Reference Boards has been tested by Infineon Technologies only as described in this document. The design is not qualified in terms of safety requirements, manufacturing and operation over the entire operating temperature range or lifetime.

The Evaluation Boards and Reference Boards provided by Infineon Technologies are subject to functional testing only under typical load conditions. Evaluation Boards and Reference Boards are not subject to the same procedures as regular products regarding returned material analysis (RMA), process change notification (PCN) and product discontinuation (PD).

Evaluation Boards and Reference Boards are not commercialized products, and are solely intended for evaluation and testing purposes. In particular, they shall not be used for reliability testing or production. The Evaluation Boards and Reference Boards may therefore not comply with CE or similar standards (including but not limited to the EMC Directive 2004/EC/108 and the EMC Act) and may not fulfill other requirements of the country in which they are operated by the customer. The customer shall ensure that all Evaluation Boards and Reference Boards will be handled in a way which is compliant with the relevant requirements and standards of the country in which they are operated.

The Evaluation Boards and Reference Boards as well as the information provided in this document are addressed only to qualified and skilled technical staff, for laboratory usage, and shall be used and managed according to the terms and conditions set forth in this document and in other related documentation supplied with the respective Evaluation Board or Reference Board.

It is the responsibility of the customer’s technical departments to evaluate the suitability of the Evaluation Boards and Reference Boards for the intended application, and to evaluate the completeness and correctness of the information provided in this document with respect to such application.

The customer is obliged to ensure that the use of the Evaluation Boards and Reference Boards does not cause any harm to persons or third party property.

The Evaluation Boards and Reference Boards and any information in this document is provided "as is" and Infineon Technologies disclaims any warranties, express or implied, including but not limited to warranties of non-infringement of third party rights and implied warranties of fitness for any purpose, or for merchantability.

Infineon Technologies shall not be responsible for any damages resulting from the use of the Evaluation Boards and Reference Boards and/or from any information provided in this document. The customer is obliged to defend, indemnify and hold Infineon Technologies harmless from and against any claims or damages arising out of or resulting from any use thereof.

Infineon Technologies reserves the right to modify this document and/or any information provided herein at any time without further notice.

Safety precautions

Safety precautions

Note: Please note the following warnings regarding the hazards associated with development systems.

Table 1 Safety precautions

	<p>Warning: The DC link potential of this board is up to 1000 VDC. When measuring voltage waveforms by oscilloscope, high voltage differential probes must be used. Failure to do so may result in personal injury or death.</p>
	<p>Warning: The evaluation or reference board contains DC bus capacitors which take time to discharge after removal of the main supply. Before working on the drive system, wait five minutes for capacitors to discharge to safe voltage levels. Failure to do so may result in personal injury or death. Darkened display LEDs are not an indication that capacitors have discharged to safe voltage levels.</p>
	<p>Warning: The evaluation or reference board is connected to the grid input during testing. Hence, high-voltage differential probes must be used when measuring voltage waveforms by oscilloscope. Failure to do so may result in personal injury or death. Darkened display LEDs are not an indication that capacitors have discharged to safe voltage levels.</p>
	<p>Warning: Remove or disconnect power from the drive before you disconnect or reconnect wires, or perform maintenance work. Wait five minutes after removing power to discharge the bus capacitors. Do not attempt to service the drive until the bus capacitors have discharged to zero. Failure to do so may result in personal injury or death.</p>
	<p>Caution: The heat sink and device surfaces of the evaluation or reference board may become hot during testing. Hence, necessary precautions are required while handling the board. Failure to comply may cause injury.</p>
	<p>Caution: Only personnel familiar with the drive, power electronics and associated machinery should plan, install, commission and subsequently service the system. Failure to comply may result in personal injury and/or equipment damage.</p>
	<p>Caution: The evaluation or reference board contains parts and assemblies sensitive to electrostatic discharge (ESD). Electrostatic control precautions are required when installing, testing, servicing or repairing the assembly. Component damage may result if ESD control procedures are not followed. If you are not familiar with electrostatic control procedures, refer to the applicable ESD protection handbooks and guidelines.</p>
	<p>Caution: A drive that is incorrectly applied or installed can lead to component damage or reduction in product lifetime. Wiring or application errors such as undersizing the motor, supplying an incorrect or inadequate AC supply, or excessive ambient temperatures may result in system malfunction.</p>
	<p>Caution: The evaluation or reference board is shipped with packing materials that need to be removed prior to installation. Failure to remove all packing materials that are unnecessary for system installation may result in overheating or abnormal operating conditions.</p>

Table of contents

About this document.....	1
Important notice	2
Safety precautions.....	3
Table of contents.....	4
1 The board at a glance.....	6
1.1 Delivery content	6
1.2 Block diagram.....	7
1.3 Main features	9
1.4 Board parameters and technical data	10
2 System and functional description	12
2.1 Commissioning.....	12
2.1.1 Hardware connection	12
2.1.2 Software tools preparation.....	13
2.1.3 Firmware preparation	13
2.1.4 Parameter and script files preparation	13
2.1.5 Program firmware/parameters/script.....	18
2.1.6 Open-loop diagnostic	20
2.1.7 Closed loop run	21
2.1.8 Infrared control commissioning.....	22
2.2 Description of the main board functional blocks.....	23
2.2.1 EMI filter and surge protection	23
2.2.2 DC bus sensing and MCEWizard configuration	23
2.2.3 Inverter section	24
2.2.4 Motor current sensing and overcurrent protection	25
2.2.4.1 Motor current sensing.....	25
2.2.4.2 Motor overcurrent protection.....	27
2.2.5 PFC section	28
2.2.6 PFC current sensing and overcurrent protection	28
2.2.6.1 PFC current sensing	28
2.2.6.2 PFC overcurrent protection	29
2.2.7 Interface circuit of IMD112T	30
2.2.8 Interface circuit to XMC daughter board	31
2.3 Description of the daughter board functional blocks.....	32
2.3.1 Circuit of daughter board.....	32
2.3.2 Output duty signals versus infrared control box buttons.....	32
2.4 Description of script code	34
3 System design.....	39
3.1 Schematics	39
3.2 Layout	39
3.2.1 Main board layout	39
3.2.2 Daughter board layout.....	41
3.3 Bill of material	43
3.4 Connector details	44
3.4.1 Main board connectors	44
3.4.2 Daughter board connectors.....	45
4 System performance	46

Table of contents

4.1	PFC iTHD at rated condition	46
4.2	Bus voltage ripple.....	46
4.3	PFC IGBT Vce dv/dt performance	47
4.4	PFC thermal performance.....	49
4.5	Inverter IGBT dv/dt performance	50
4.6	Inverter IGBT dead time test.....	52
4.7	System test with infrared control	52
5	References and appendices	54
5.1	Abbreviations and definitions.....	54
5.2	References	54
5.3	Additional information.....	54
	Revision history.....	55

The board at a glance

1 The board at a glance

The REF-SHA35WRC2SYS is a part of Infineon's TRENCHSTOP™ IGBT, gate driver and iMOTION™ driver reference design kits. It is designed to provide a ready-to-use ceiling fan solution based on the above-mentioned technology as well as on the advanced motion control engine (MCE 2.0).

The REF-SHA35WRC2SYS is an optimized design for 35 W high voltage ceiling fan applications. It allows fast prototyping and a fast time to market. It is available through regular Infineon distribution partners as well as on Infineon's website. The main features of this board are described in Chapter 1.3 of this document. The remaining sections provide information for customers, enabling them to copy and modify the design for production according to their specific requirements.

Environmental conditions have been considered in the design of the REF-SHA35WRC2SYS. The design was tested as described in this document, but not qualified in terms of safety requirements or manufacturing and operation over the whole operating temperature range or lifetime. The boards provided by Infineon are subject to functional testing only.

The boards are not subject to the same procedures as regular products in terms of returned material analysis (RMA), process change notification (PCN) and product discontinuation (PD).

1.1 Delivery content

The scope of delivery contains the main board REF-SHA35WRC2SYS and daughter board XMC1100_IR_RC as shown in Figure 2 to Figure 5, one connecting cable, and remote infrared control box. The detailed ordering information is indicated in Table 2.

Table 2 Delivery content

Base part number	Package	Standard pack		Orderable part number
		Form	Quantity	
REF-SHA35WRC2SYS		Boxed	1	REFSHA35WRC2SYSTOBO1
XMC1100_IR_RC		Boxed	1	
Cable		Boxed	1	
Remote infrared control box		Boxed	1	

The board at a glance

1.2 Block diagram

The block diagram of the REF-SHA35WRC2SYS is depicted in Figure 1.

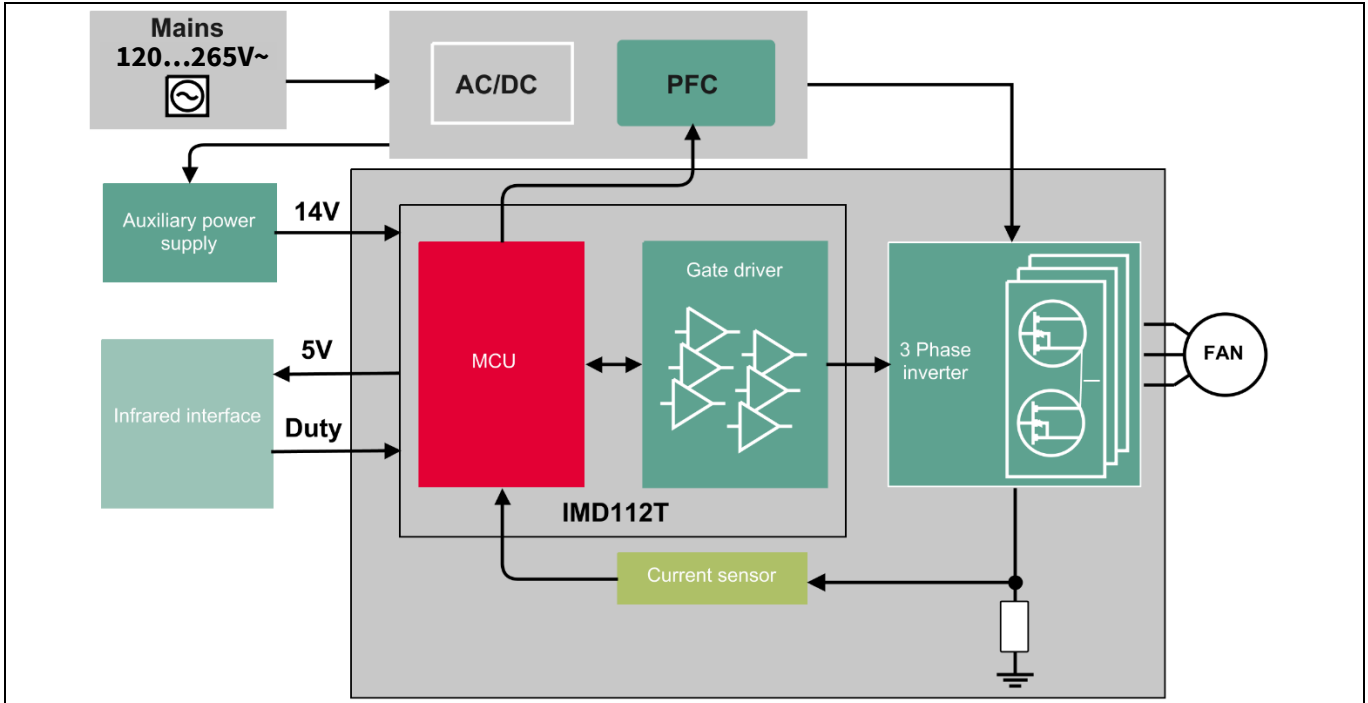

Figure 1 Block diagram of the REF-SHA35WRC2SYS

Figure 2 to Figure 5 depict the functional groups of the main board REF-SHA35WRC2SYS and daughter board XMC1100_IR_RC.

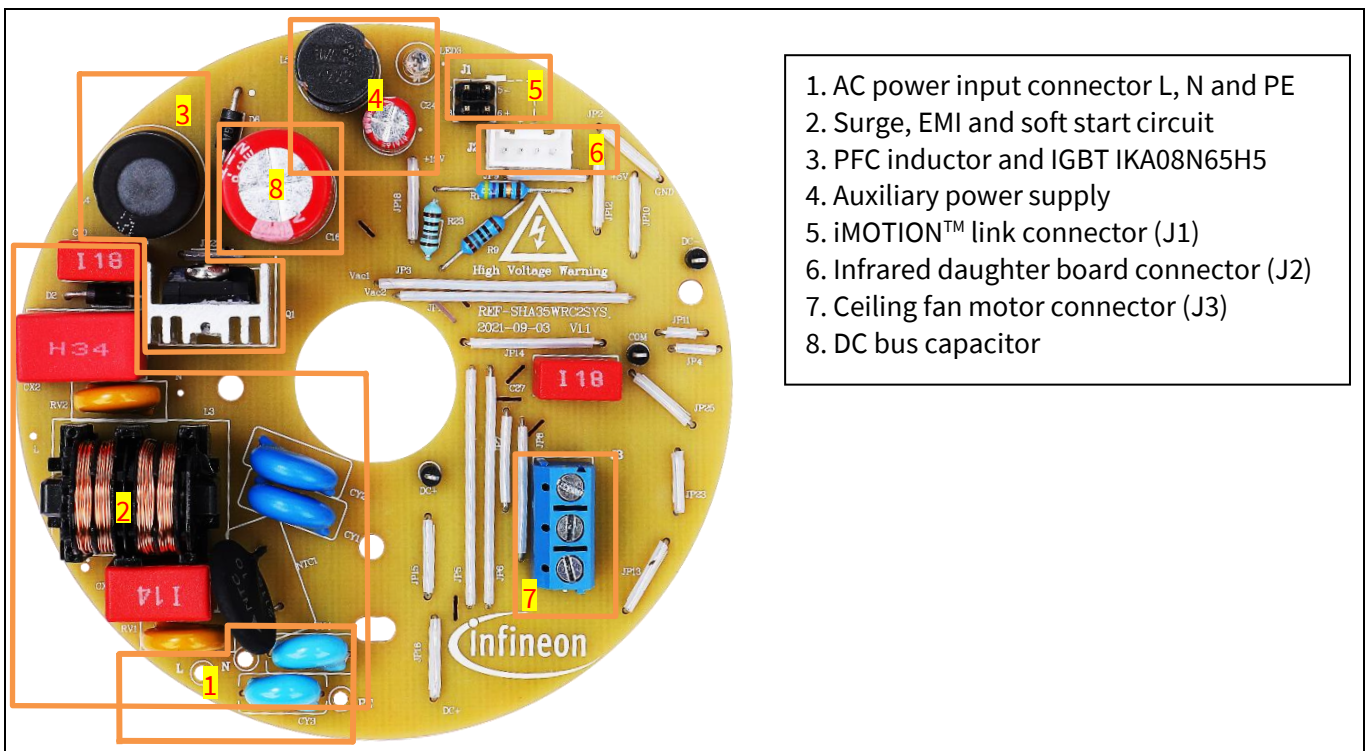

Figure 2 Functional groups on top side of the main board REF-SHA35WRC2SYS

REF-SHA35WRC2SYS user guide

High voltage ceiling fan reference design

The board at a glance

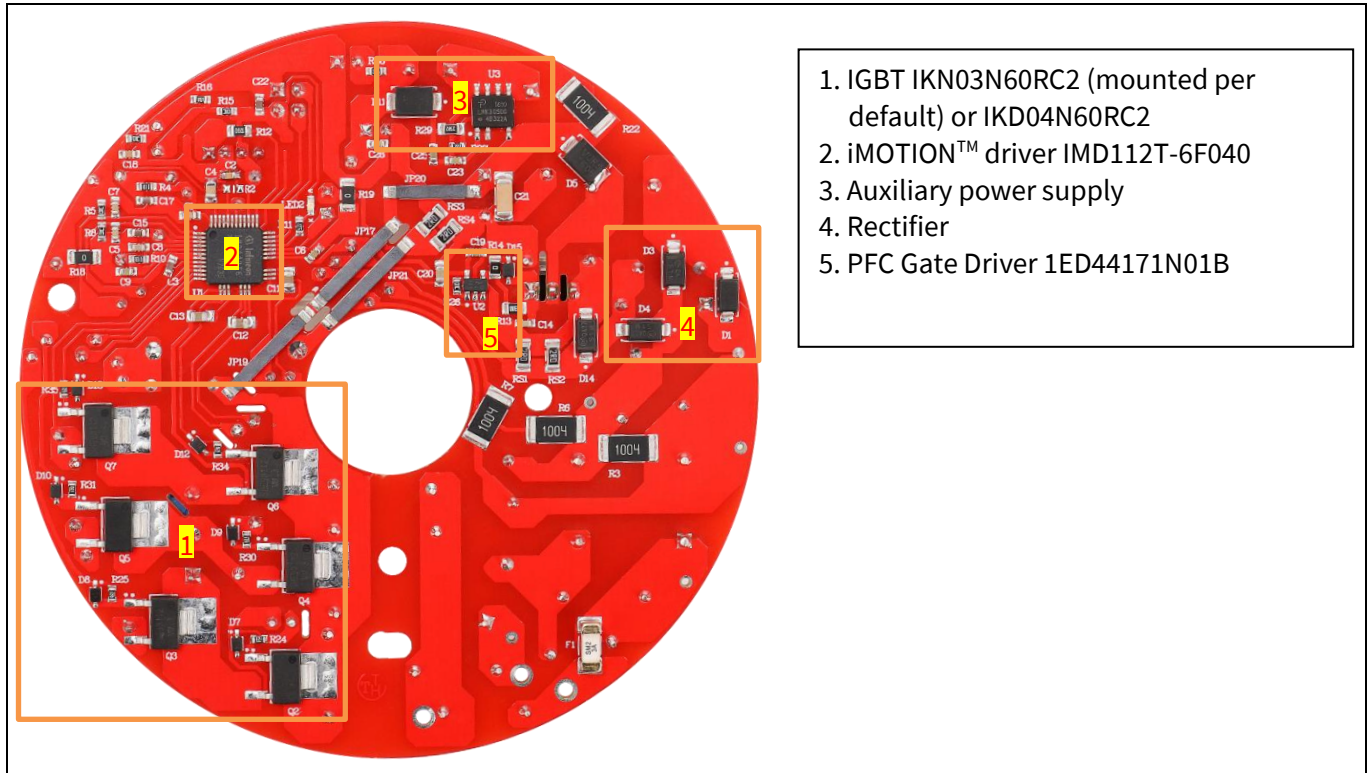

Figure 3 Functional groups on bottom side of the main board REF-SHA35WRC2SYS

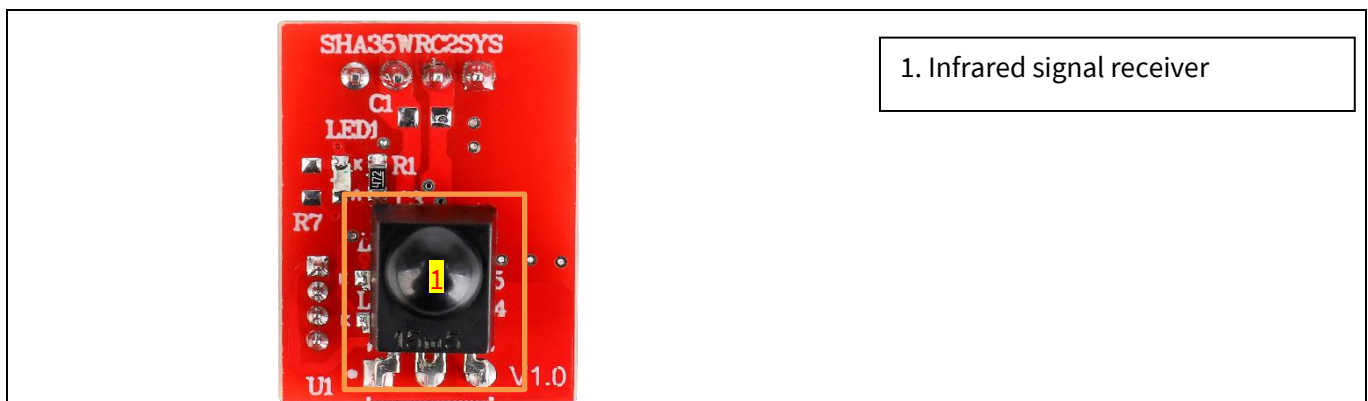

Figure 4 Functional groups on top side of the daughter board XMC1100_IR_RC

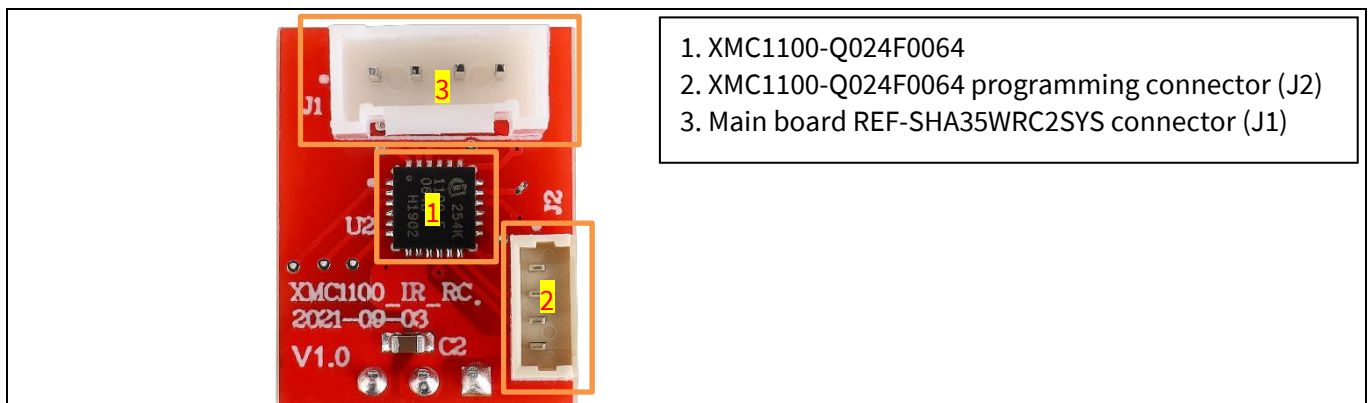

Figure 5 Functional groups on bottom side of the daughter board XMC1100_IR_RC

The board at a glance

1.3 Main features

The REF-SHA35WRC2SYS board is an optimized reference design for 230 V_{rms} ceiling fan applications. It contains iMOTION™ driver IMD112T for controller and inverter driver, TRENCHSTOP™ RC-Series cost-effective, monolithically integrated IGBT with diode IKN03N60RC2 for inverter switches, 650 V DuoPack IGBT and diode IKA08N65H5 for PFC switch, and 1ED44171N01B for PFC gate driver.

Major REF- SHA35WRC2SYS characteristics include:

- Infrared remote interface for ceiling fan speed control
- Last-used setting speed command restore function after re-power
- DC bus tracking input voltage in PFC control
- Input voltage range 120~265 V_{rms}, Normal input voltage 230 V_{rms}, DC-bus voltage of up to 450V
- Maximum input power 35 W at T_{vj}=25°C with input voltage range of 120~265 V_{rms}
- PFC factor ≥ 0.9 at normal input voltage 230 V_{rms} and maximum input power of 35 W
- iTHD ≤ 10% at normal input voltage 230 V_{rms} and maximum input power of 35 W
- 650 V DuoPack IGBT and diode for PFC switch
- Single-channel, low-side IGBT gate driver IC for PFC switch driver
- On-board 0.3 A, 10 mH PFC inductor for 60 kHz PFC operation
- Cost-effective, monolithically integrated 600 V Reverse Conducting Driver 2 for 16 kHz PWM motor control
- iMOTION™ driver for PFC and motor control
- Overcurrent protection
- Auxiliary power supply with 14 V
- 5 V supply by on-board iMOTION™ driver
- Main board PCB with 90 mm diameter cycle, single layer, 1 oz. copper
- Daughter board with 15 mm x 9 mm, 2 layers, 1 oz. copper
- RoHS compliant

The board at a glance

1.4 Board parameters and technical data

Table 3 depicts the key specifications of the reference design of REF-SHA35WRC2SYS.

Table 3 REF-SHA35WRC2SYS board specifications

Parameter	Symbol	Conditions	Value	Unit
Input voltage	V_{ac}	Optimized design for 230 V_{rms} applications	120 ~ 265	V_{rms}
Maximum input current	$I_{ac(max)}$	Input 120 V_{rms} , input power = 35W, $T_a=25^{\circ}C$, Motor $f_{PWM}=16$ kHz, PFC $f_{PWM}=60$ kHz natural cooling mode	290	mA_{rms}
Normal input current	$I_{ac(norm)}$	Input 230 V_{rms} , input power = 35W, $T_a=25^{\circ}C$, Motor $f_{PWM}=16$ kHz, PFC $f_{PWM}=60$ kHz natural cooling mode	155	mA_{rms}
Maximum input power	$P_{in(max)}$	Input 120 ~ 265 V_{rms} , input power = 35W, $T_a=25^{\circ}C$, natural cooling mode	35	W
Maximum motor current	$I_{mtr(max)}$	Input 230 V_{rms} , input power = 35W, $T_a=25^{\circ}C$, Motor $f_{PWM}=16$ kHz, PFC $f_{PWM}=60$ kHz, Natural cooling mode	130	mA_{rms}
DC bus voltage				
Maximum DC bus voltage	$V_{dc(max)}$	DC bus capacitors are 450 V, 22 μF	450	V
Minimum DC bus voltage	$V_{dc(min)}$	Aux power supply brown-in voltage	25	V
Current feedback				
PFC shunt resistance	RS1	Direct AD sample, two 0.25 W, 2 Ω shunt resistor paralleled	1	Ω
Motor shunt resistance	RS2	Direct AD sample, two 0.25 W, 2 Ω shunt resistor paralleled	1	Ω
Protections				
PFC current protection trigger level	$PFCI_{trip}$	IMD112T's internal comparator for cycle-by-cycle OCP, trip level can be adjusted by R15 & R16	853 ¹	mA_{peak}
Motor current protection trigger level	$Mtrl_{trip}$	Wizard setup for OC trigger level, related to AD range, shunt resistor RS3, RS4 and pull-up bias	500 ²	mA_{peak}
Auxiliary power supply1 – 14V				
Output voltage	V_{AUout1}	Used for IPM driver	14 \pm 2%	V
Maximum output current	I_{AUout1}		175	mA

¹ For iMOTION™ IC IMD112T PFC overcurrent protection, there are two options in the MCEWizard setup.

If you select “Cycle-By-Cycle” mode, the PWM output immediately goes to logic LOW when the inductor current exceeds the pre-determined OCP threshold, and re-starts at the following PWM cycle.

If you select “Latch-off” mode, PFC state machine would shift from RUN state to FAULT state when the inductor current exceeds the pre-determined OCP threshold for a duration specified by parameter “PFC_GateKillTime”, only Fault_clear command can make it back to STOP/RUN mode.

² For iMOTION™ IC IMD112T, there is only one type of Gatekill input source in MCEWizard setup: comparator. The feedback current will be compared by the internal comparator with the “Overcurrent Trip Level for Internal GateKill Comparator” value set in MCEWizard.

The board at a glance

Parameter	Symbol	Conditions	Value	Unit
Auxiliary power supply2 – 5V				
Output voltage	V_{AUout2}	Supplied by IMD112T and power daughter board	$5 \pm 4\%$	V
Maximum output current	I_{AUout2}		10	mA
PCB characteristics				
Main board dimension		Diameter× height, single layer	90×65	mm
Material		FR4, 1.6 mm thickness, 1 oz. PCB		
Daughter board dimension		Length × width × height, double layer	19×15 ×11	mm
Material		FR4, 1.6 mm thickness, 1 oz. PCB		
System environment				
Ambient temperature	T_a	Non-condensing, maximum RH of 95%	0 ~ 50	°C

2 System and functional description

2.1 Commissioning

This section describes how to get the system working after the user has installed the board. The following items detail these steps. For those who are familiar with the system, or who have already run the board, some of the steps can be skipped, depending on the user's situation. For more in-depth start-up requirements, please refer to the MCE reference manual or the corresponding reference material^{[4][5][6]}.

2.1.1 Hardware connection

Figure 6 shows the hardware connection details for the reference design board.

The **iMOTION™ link** cable is needed to bridge the PC/debugger side and motor drive system (the target iMOTION™ device, hot side) with 1 kV DC galvanic isolation. Users can go to Section 5.3 for more information on the iMOTION™ link.

1. Connect iMOTION™ link's 8-pin cable to main board J1 using the default pin order (only pin 5~8 are used), and connect PC and iMOTION™ link with the USB wire.
2. Then connect AC power supply (L, N, PE) and the motor (J3).
3. Connect main board J2 to daughter board J1 by cable attached in package box.

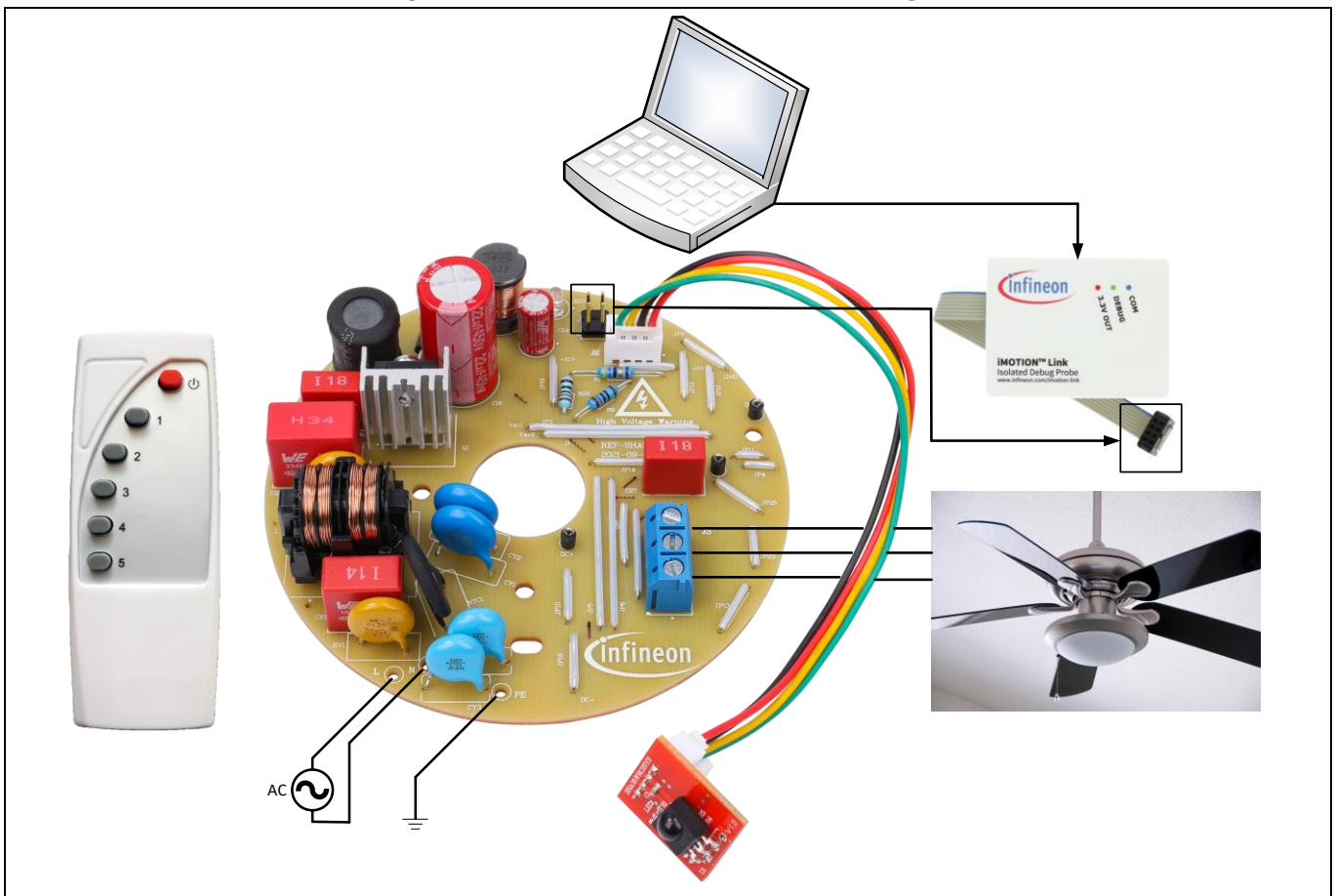

Figure 6 Hardware connection details

Note: The iMOTION™ link shown in Figure 6 is required for commissioning, but it is not included in the delivery content. It can be ordered separately according to the details in Section 5.3.

System and functional description

2.1.2 Software tools preparation

The iMOTION™ software tools, MCEDesigner and MCEWizard, are required to set up the system, as well as to control and fine-tune the system performance to match users' needs. These tools are available for download via the Infineon website (<http://www.infineon.com/imotion-software>). Please check this page periodically for software tools updates. Regarding the use of MCEDesigner and MCEWizard, please refer to the “MCEDesigner Application Guide” and the “MCEWizard User Guide,” which can be got in the installing path of each tools.

Note: This reference board has been tested by the software tools MCEdesigner v2.3.1 and MCEWizard v2.3.1. The same performance is not guaranteed for updated software tools.

2.1.3 Firmware preparation

Please download MCE firmware via the Infineon website (<http://www.infineon.com/imotion-software>). Select the firmware package “IMD112T-F040 MCE Software Package v x.x.x.” and please check this page periodically for MCE firmware updates. The key files included in the package for IMD112T-F040 commissioning are shown below.

- a) Firmware (‘.ldf’)
- b) Default parameters (‘.txt’)
- c) Default map file (‘.map’)
- d) MCEDesigner file(‘.irc’).

Note: This reference board has been tested by MCE firmware IMD112T-F040 MCE Software Package v1.3.3. The same performance is not guaranteed for updated software tools and MCE firmware.

Note: This reference bord has been programmed firmware IMD112T-F040_A_V1.03.03.ldf before shipment, so you can re-programmed firmware or not.

2.1.4 Parameter and script files preparation

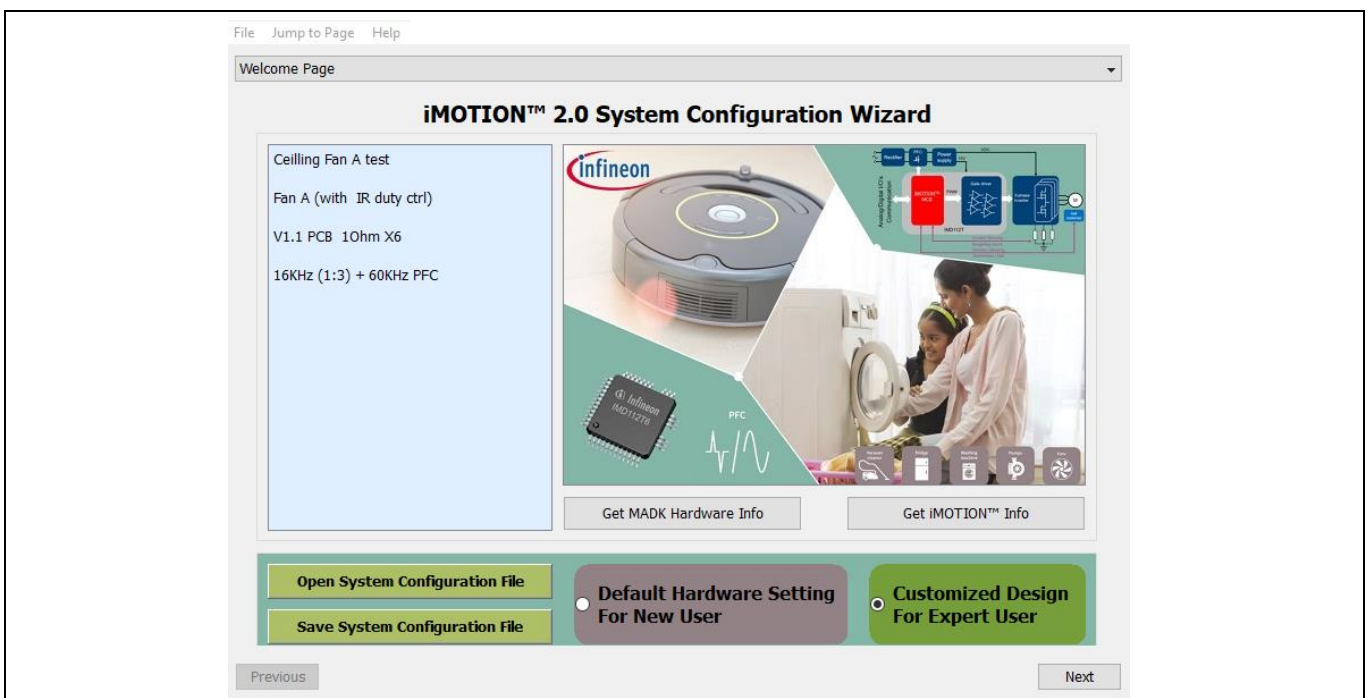

Figure 7 Wizard welcome page

System and functional description

If you are not familiar with the application of iMOTION™, you can log-in to myInfineon and make product registration, then download the default software package for this reference board. The package includes only one MCEWizard file (‘.mc2’) in which all the parameters related to the board hardware and script code for remote infrared control have been already configured. To make things easier and save time, you only need to modify the parameters related to your motor, and generate the parameters as the steps described below.

1. Use MCEWizard to open the MCEWizard file (‘.mc2’) as shown in Figure 7, then enter the target motor’s system parameters in “Advanced Mode > Motor 1” as shown in Figure 8, which will be used to calculate the controller’s digital parameter set, representing the complete motor drive system.

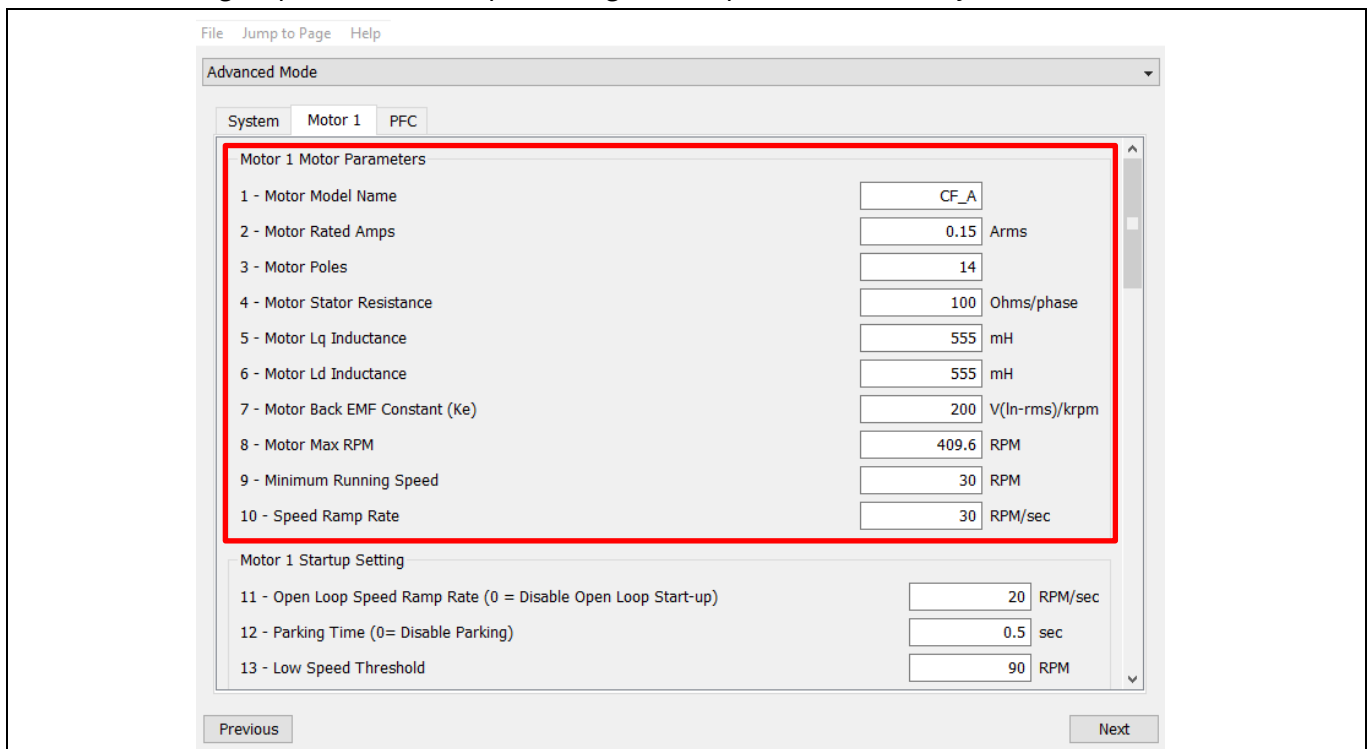

Figure 8 Motor parameters input

2. To perfect motor running performance, the key motor control parameters listed in Table 4 may need to be modified in your commissioning process.

Table 4 Key parameters for perfecting motor running performance

Name of item in MCEWizard	Description¹
Open loop speed ramp rate	Influence motor start up performance.
Parking time	Influence motor start up performance.
Low speed threshold	Influence motor start up performance.
Low speed current limit	Influence motor start up performance.
Current regulator bandwidth	Influence motor steady-state running performance.
Speed regulator proportional gain	Influence motor steady-state running performance.
Speed regulator integral gain	Influence motor steady-state running performance.

¹ Only the influence of each key parameter is briefly described here. For more information of each parameters, please refer to the description in MCEWizard.

System and functional description

3. If the script function for remote infrared control is needed for commissioning, then please go to step 4. If the script function is not needed for motor initial open-loop and closed-loop commissioning, then please go to step 5.
4. The script function is enabled by default in the provided MCEWizard file (.mc2). Click menu “Jump to page > Script” and click label “Script Coding”, then you can edit the script code according to the properties of motor you used as shown in Figure 13. For more information regarding to script editing, please refer to the MCE reference manual^[6]. About how to change script to adapt customer motor, please refer to Section 2.4. Then click menu “Jump to page > Verify & Save Page”, go to “Verify & Save Page” page and click on the “Calculate Parameters and Compile Script Code” key to calculate parameters and compile script code. If no errors are reported, then save the drive parameters set in your project directory by clicking “Export to Designer file (.txt)” as shown in Figure 9. If errors are detected, double-click on the error message (highlighted in RED) and adjust the related parameters. The saved drive system parameter file will later be used for programming.

The output files of this step are below:

Table 5 Files generated by MCEwizard (script-enabled)

Suffix of file	Description
.map	Includes the avriables defined in script code and need to import into MCEDesigner .irc file.
.ldf	The code compiled from script code and need to programme.
.txt	The parameters for this board hardware and need to programme.

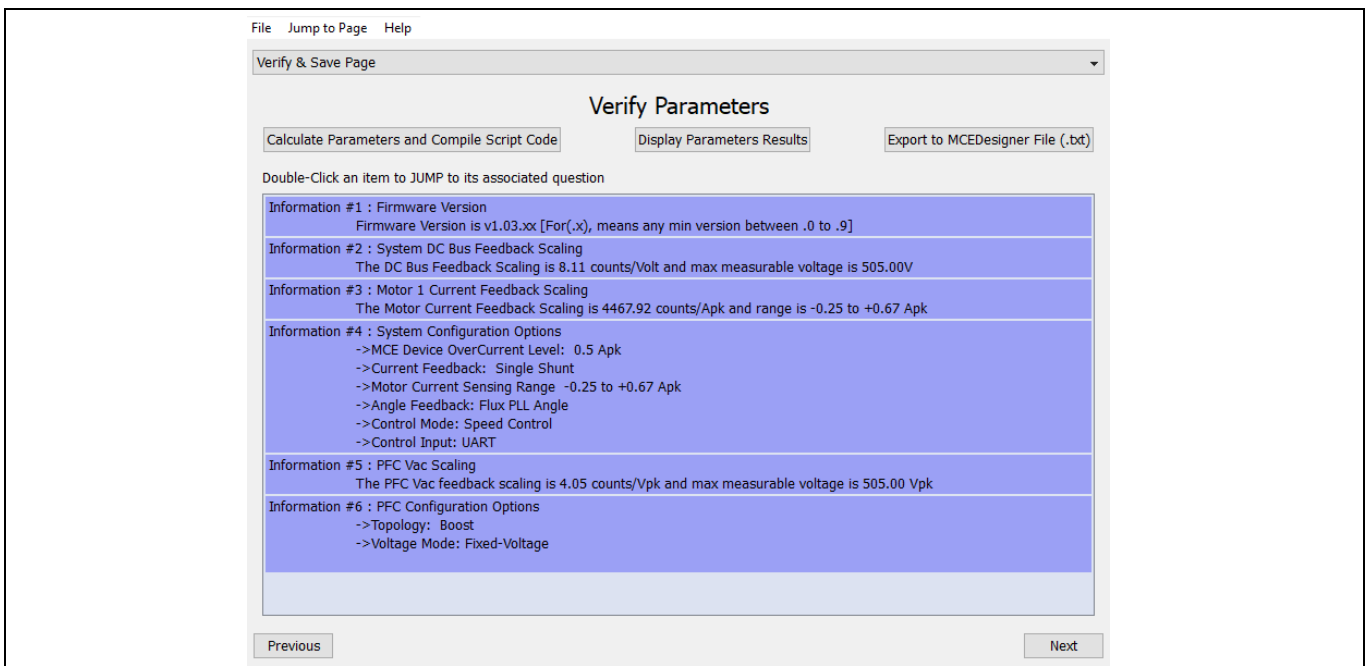

Figure 9 Verify and save page (script-enabled)

5. Click menu “Jump to page > Option” and disable script function as shown in Figure 10. Then click menu “Jump to page > Verify & Save Page”, go to “Verify & Save Page” page and click on the “Calculate Parameters” key to calculate parameters. If no errors are reported, then save the drive parameters set in your project directory by clicking “Export to Designer file (.txt)” as shown in Figure 11. If errors are detected, double-click on the error message (highlighted in RED) and adjust the related parameters. The saved drive system parameter file will later be used for programming.

System and functional description

The output files of this step are below:

Table 6 Files generated by MCEwizard (script-disabled)

Suffix of file	Description
.txt	The parameters for this board hardware and need to programme.

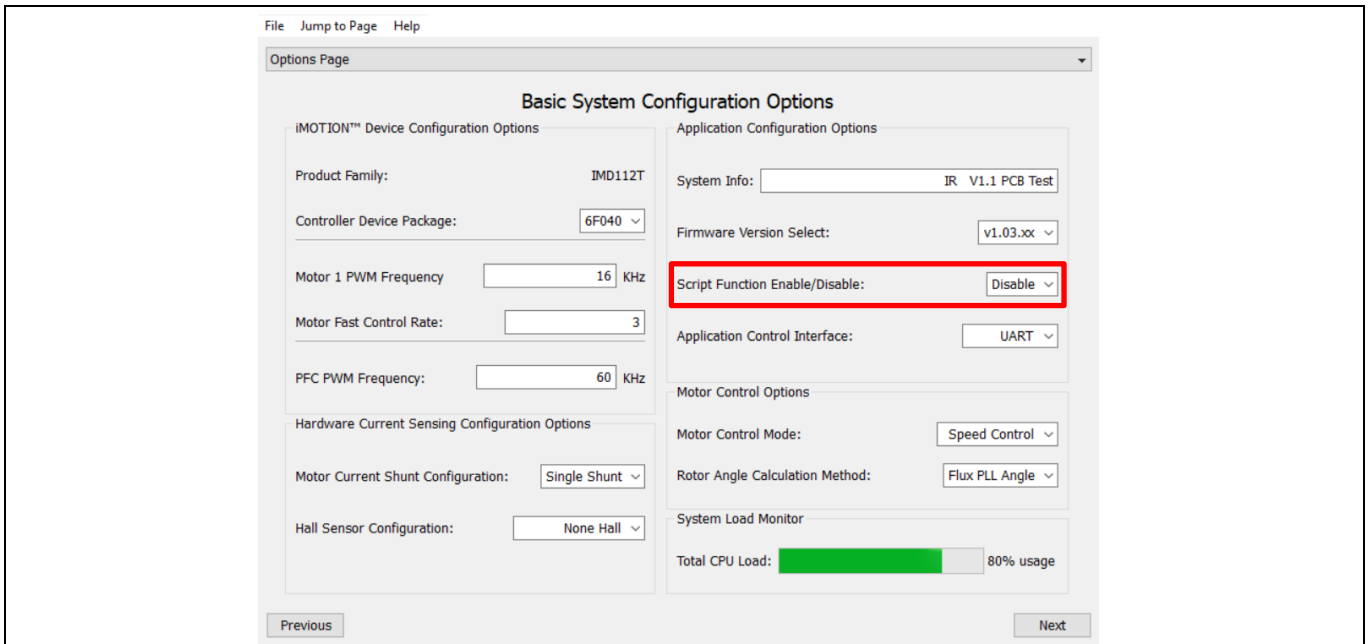

Figure 10 Enable/Disable script function in options page

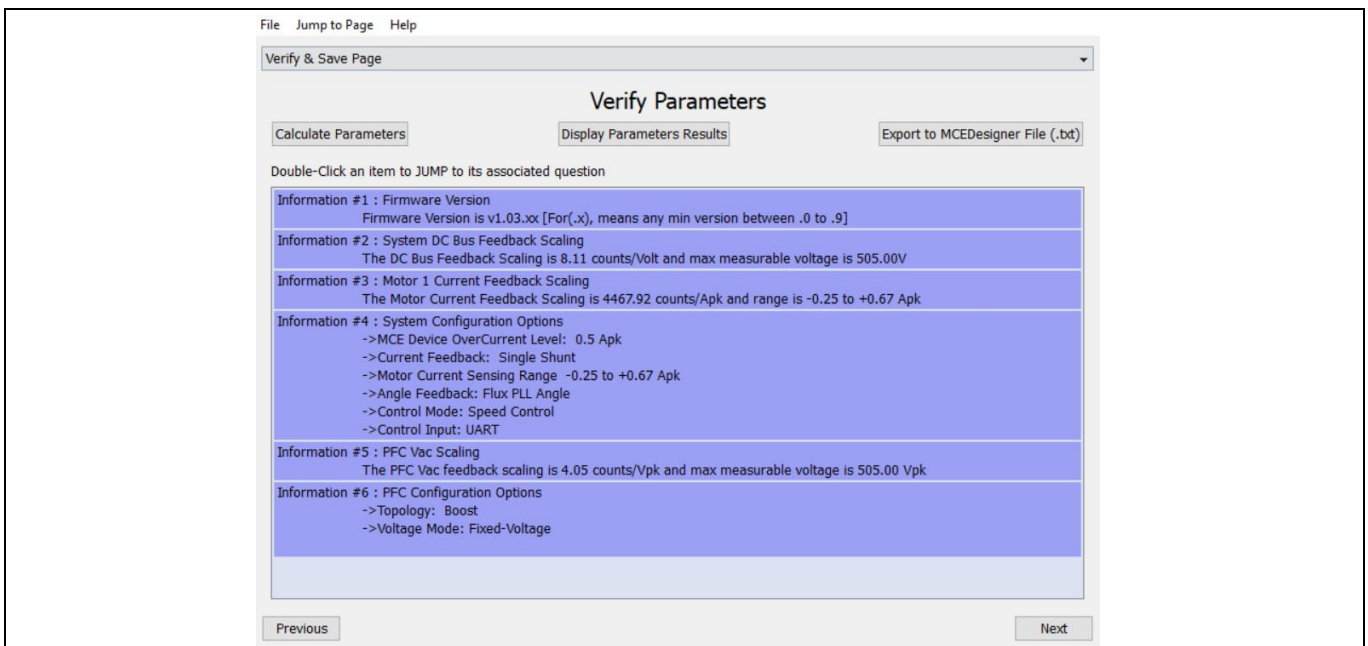

Figure 11 Verify and save page (script-disabled)

System and functional description

If you are familiar with the application of iMOTION™, you can open MCEWizard and click menu “File > Create System Configuration File” to create a new configuration file for IMD112T as shown in Figure 12. Then select “Customized Design For Expert User” and configure as below steps:

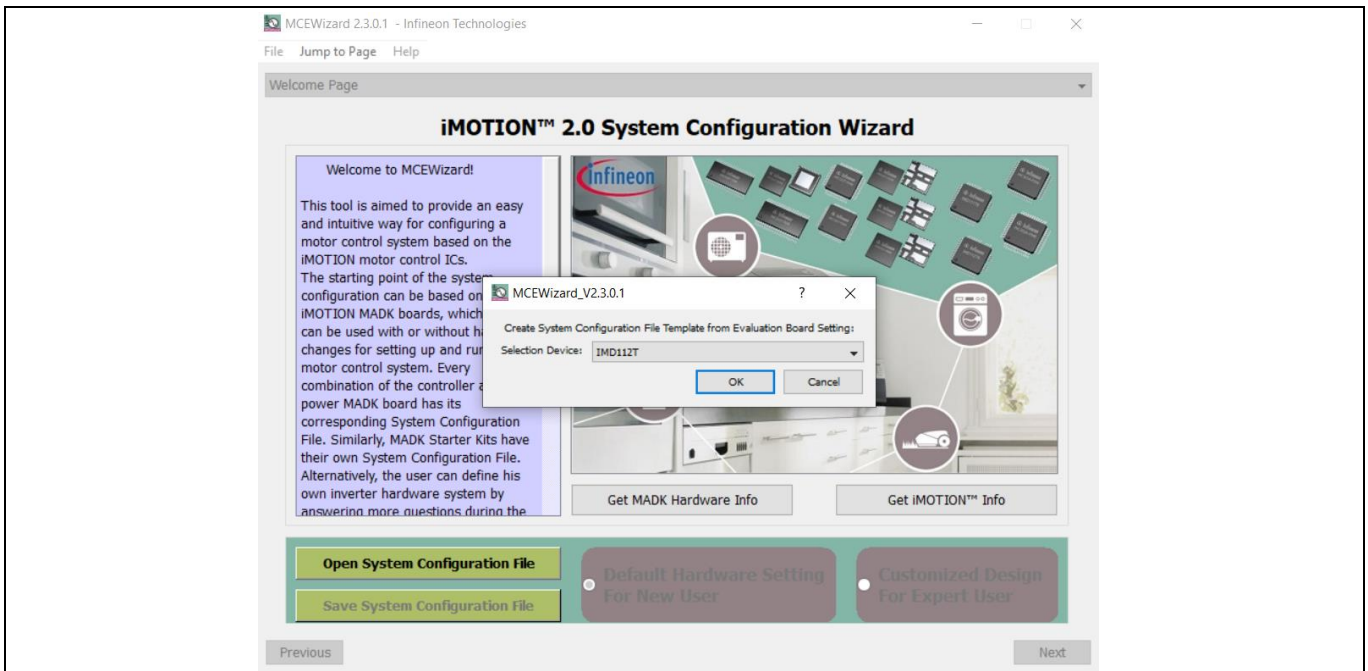

Figure 12 New configuration file created for IMD112T

1. Enter the target motor’s system and operating parameters, as well as the reference board’s hardware parameters step by step according to MCEWizard user guide^[4].
2. If the script function for remote infrared control is needed for commissioning, then please go to step 3. If the script function is not needed for motor initial open-loop and closed-loop commissioning, then please go to step 4.
3. Click menu “Jump to page > Option” and enable script function as shown in Figure 10. Copy the script code for remote infrared control in the Code Listing 1 to “Script Edit Page > Script Coding” in the MCEWizard as shown in Figure 13. For more information regarding to script editing, please refer to the MCE reference manual^[6]. About how to change script to adapt customer motor, please refer to Section 2.4. Then define pulse input pin for remote infrared control as shown in Figure 14, and please define the pin “GPIO13/DUTYFREQ/PFCG1” as input for this reference board. Then click menu “Jump to page > Verify & Save Page”, go to “Verify & Save Page” page and click on the “Calculate Parameters and Compile Script Code” key to calculate parameters and compile script code. If no errors are reported, then save the drive parameters set in your project directory by clicking “Export to Designer file (.txt)” as shown in Figure 9. If errors are detected, double-click on the error message (highlighted in RED) and adjust the related parameters. The saved drive system parameter file will later be used for programming.
The output files of this step are same as Table 5.
4. Click menu “Jump to page > Option” and disable script function as shown in Figure 10. Then click menu “Jump to page > Verify & Save Page”, go to “Verify & Save Page” page and click on the “Calculate Parameters” key to calculate parameters. If no errors are reported, then save the drive parameters set in your project directory by clicking “Export to Designer file (.txt)” as shown in Figure 11. If errors are detected, double-click on the error message (highlighted in RED) and adjust the related parameters. The saved drive system parameter file will later be used for programming.
The output files of this step are as same as Table 6.

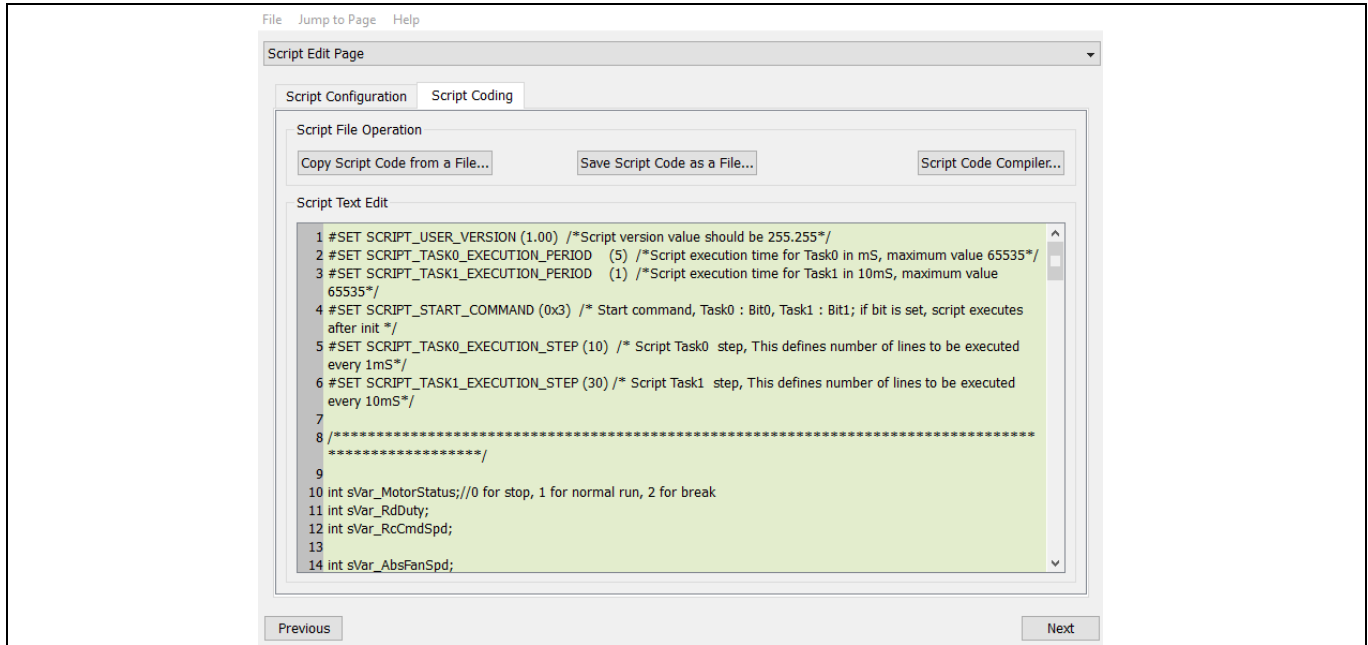

Figure 13 Script edit page

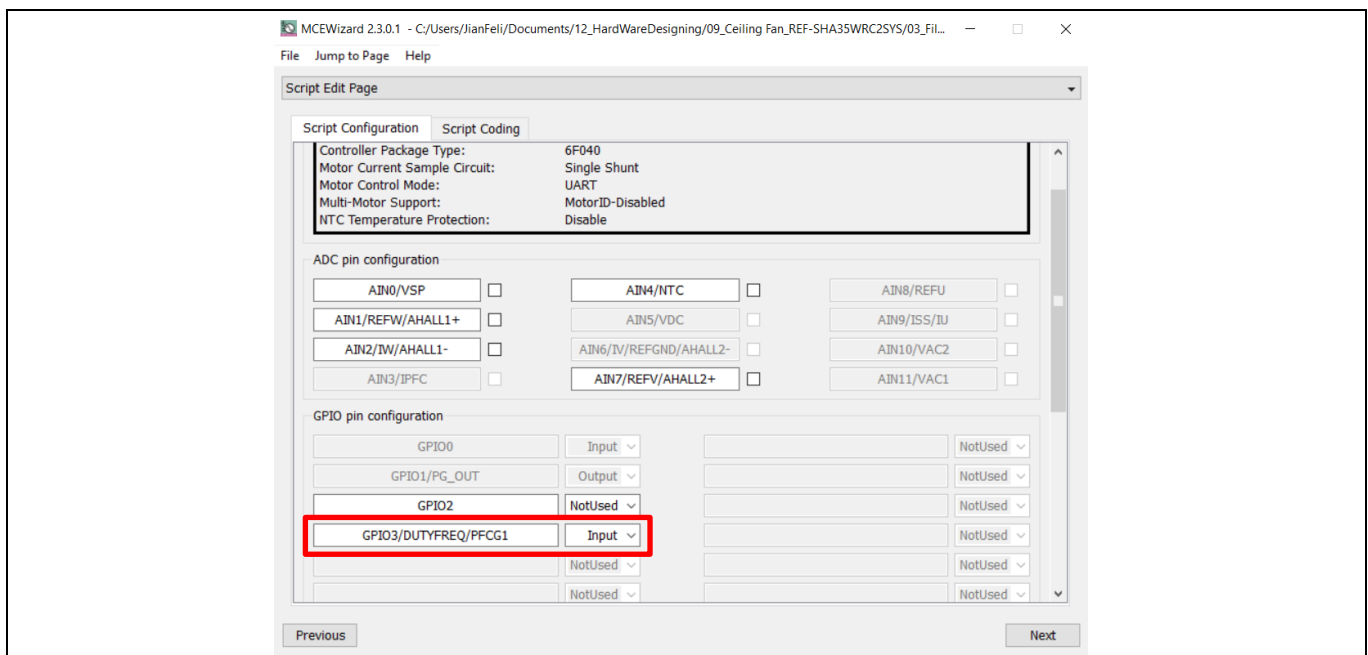

Figure 14 Pulse input pin definition for remote infrared control

2.1.5 Program firmware/parameters/script

The REF-SHA35WRC2SYS reference design kit is shipped with pre-programmed firmware, parameters and script code for remote infrared control, since the functional tests are performed before the shipment. Users need to program their parameters, as the users' ceiling fan motor may be different from the one under test.

Program the IMD112T-6F040 as follows:

- Program the firmware of the MCE
- Program parameter sets for system and motor
- Program customer script file (optional, depending on whether script function is required)

System and functional description

- or
- Program the combined file, which is generated by MCEWizard, and contains all three items above. Customer script file is optional depending on whether it is necessary. The combined file is usually used for production, since it only needs to be programmed once.

The programming process is as follows:

1. Start the MCEDesigner tool, and open MCEDesigner file (.irc) prepared in Section 2.1.3 by clicking “File” > “Open.”
2. Power the iMOTION™ control IC with 3.3 V. It is recommended to program the IC with the 3.3 V isolated power supply that comes from the iMOTION™ link; there is a switch on the iMOTION™ link to enable/disable the 3.3 V output. The iMOTION™ control IC will also be powered by the on-board auxiliary power supply after the AC source is powered. Caution must be taken in the latter case due to high voltage.

Note: The output voltage of LDO combined in the IMD112T-6F040 is 5 V, i.e. the controller of IMD112T-6F040 is powered by 5 V. However, it is also possible to use the 3.3 V power supply in the iMOTION™ link to power the IMD112T-6F040 (for programmers).

3. MCEDesigner should automatically connect to the board using the default COM port (indicated by the green circle next to “COMx Up” status in the bottom frame of the MCEDesigner GUI) when iMOTION™ control IC is powered. If it cannot establish the connection due to an incorrect COM port, change the COM port by doing the following: click on the “System Page” window and then click on “Preferences > Connection > Connect using” and choose one of the other available COM ports from the drop-down list.
4. In case of a blank IC: If the firmware has been erased from the IMD112T-6F040, the following warning message will pop up “Target device firmware and parameters file are not programmed! Please program firmware and parameters file” as shown in Figure 15. Then you can program the firmware and parameters as described in Step 5. If it is not a blank IC, no such message will be indicated.

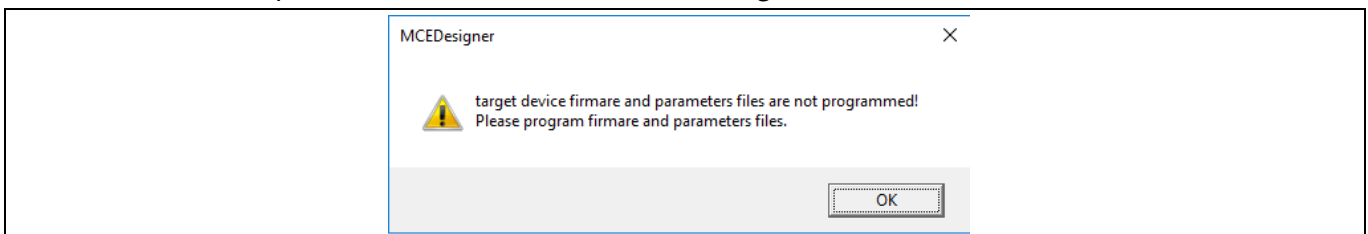

Figure 15 MCEDesigner warning message

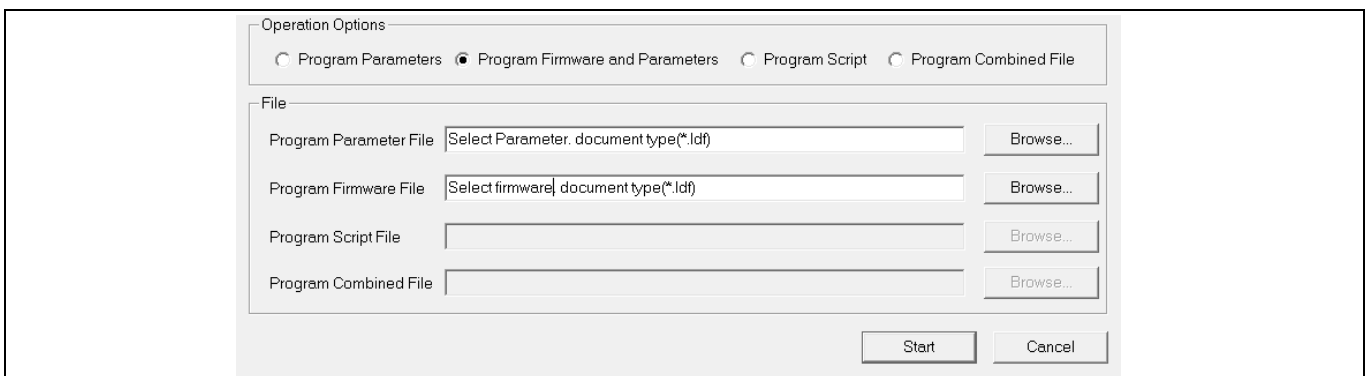

Figure 16 Program the parameters and firmware

5. Use the following steps to program the firmware and the parameters file to the internal Flash memory of iMOTION™ Control IC as follows: click on the system page, click “Tools” > “Programmer” and select

System and functional description

“Program Firmware and Parameters,” as shown in Figure 16. Regarding the firmware and parameters file, browse and select the ‘.ldf’ and ‘.txt’ file prepared in Section 2.1.3 and Section 2.1.4.

6. If the script file needs to be programmed in the internal Flash memory of iMOTION™ Control IC after programmed firmware and parameters file, still click on system page, click “Tools” > “Programmer” and select “Program Script,” shown as in Figure 17. Regarding the Script file, browse and select the ‘xxx_Script.ldf’ file prepared in Section 2.1.4. After programming script, please click “File” > “Import Register Map” to import script (.map) file into MCEDesigner file (.irc), and save this (.irc) file, otherwise a map error will appear.

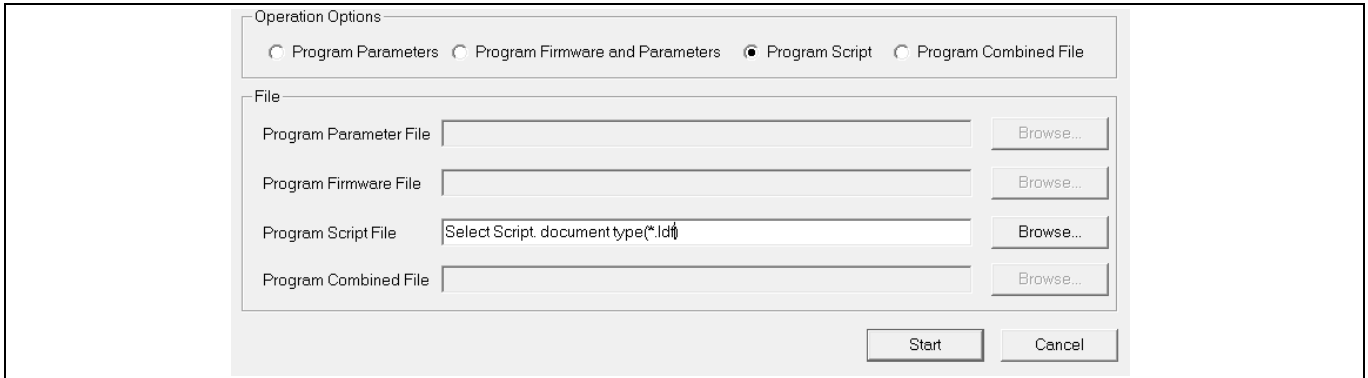

Figure 17 Program the script

Note: For detailed information on controller programming, refer to AN2018-33 iMOTION™ 2.0 device programming, MCEDesigner documentation and MCEWizard documentation.

2.1.6 Open-loop diagnostic

Make sure the input power is 230 Vrms, and program only the firmware and parameters file (script function disabled) without remote infrared script control.

Double-click the “VF Diagnostic” function in the window of motor1, and monitor motor current with oscilloscope. If the motor current is not sinusoidal, change register TargetSpeed and Vd_Ext in the VF Diagnostic sub-function, then double-click “VF Diagnostic” until the oscilloscope shows a steady sinusoidal current with an amplitude of 30~50% motor rate current.

Double-click “Iu & Iv_Slow” in “System page > Monitor Definitions.” The motor current feedback should be very clean and sinusoidal, as shown in Figure 18; otherwise please tune “Gating Driver Propagation Delay & Phase Shift Window Size” in MCEWizard.

“VF Diagnostic” sub-function can check whether:

- The ceiling fan motor is connected correctly
- The power stage works as expected
- Current-sensing related parameters are correctly configured
- The PCB layout and DC bus decoupling have been done correctly

After “VF Diagnostic” is done, click STOP button (the red traffic light button) or run the “stop motor” function to stop the motor.

Note: Please do not start PFC in this diagnostic process.

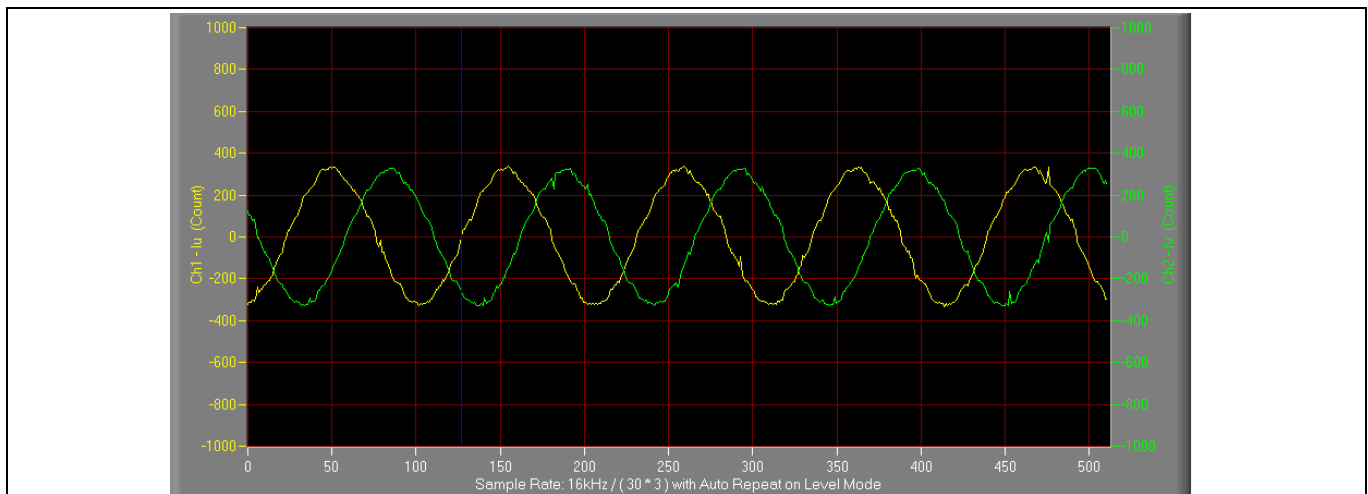

Figure 18 Trace waveform for Iu & Iv open loop diagnostic

2.1.7 Closed loop run

Make sure the input power is 230 Vrms, and only program firmware and parameters file (script function disabled) without remote infrared script.control.

If the VF Diagnostic works correctly, the hardware circuit and signal sampling will work normally, at which point you can try to run the ceiling fan motor in a closed-loop mode. Follow the steps as listed below.

1. Start the motor by clicking the green traffic light button in the control bar (or double click Start Motor sub-function in the window of motor1, which is in the group of User Application Function Definitions). The motor will run if above step works correctly.
2. Check the motor spin direction, adjust the connection order of the motor's winding; the motor spin direction must match the normal running direction of the ceiling fan.
3. Set TargetSpeed to about 50% of maximum speed, start “Iu & Flx_M” trace with “Auto Repeat on Level,” see Figure 19. Flx_M is good within the range of 2000~2500 (rated value is 2048), and must be steady and DC-like.

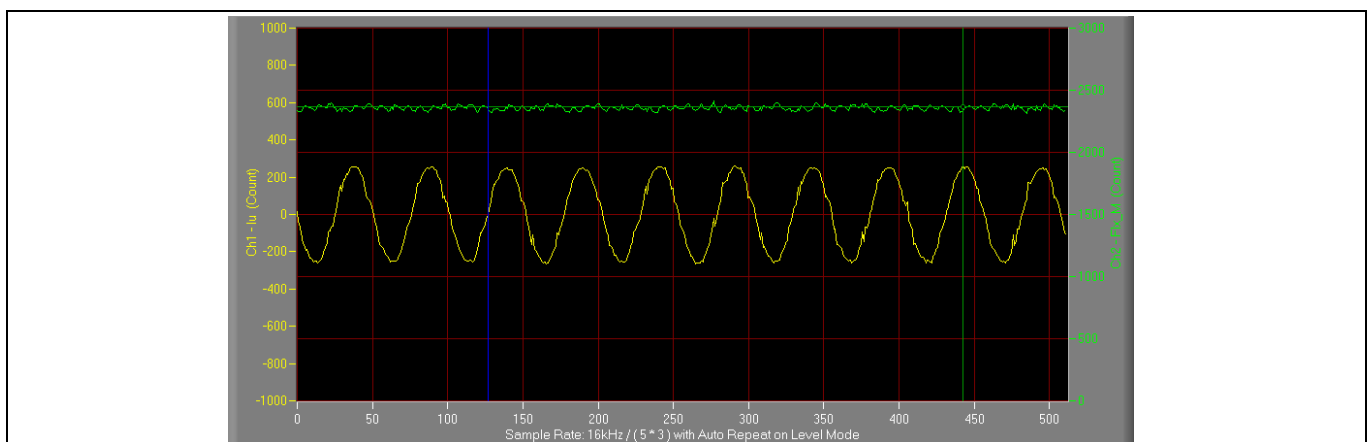

Figure 19 Trace waveform for Iu & Flx-M at 50% speed

4. If motor closed loop is tuned up, then the PFC can start when the motor is running. Starting the “PFC_AbsVac & PFC_Iref” trace with “Auto Repeat on Level” (see Figure 20) will show the PFC performance. The default PFC DC bus target value is set in MCEWizard “Target DC Bus Voltage Initialization.”

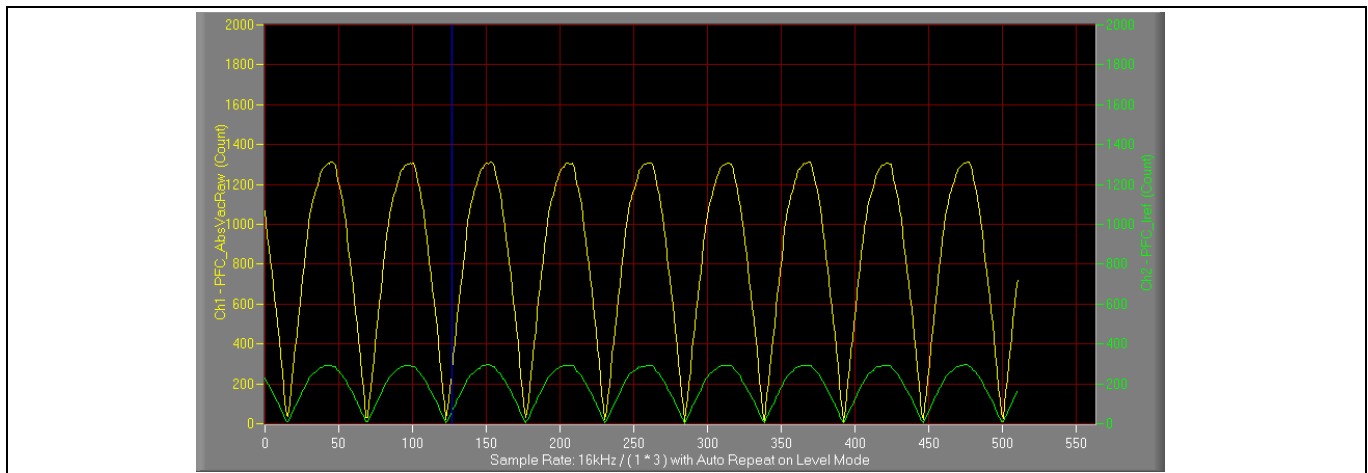

Figure 20 PFC_AbsVac & PFC_Iref

5. Once the firmware has been programmed, and only a new parameter file has to be programmed, follow the same instructions given in Section Figure 14. In this case, the firmware programming is no longer needed, and you can select the first option “Program Parameters.”

Here are some key tips for better motor-performance commissioning:

- If Flx_M is not steady (swing or oscillation), check the following: motor parameters, speed loop PI bandwidth, current loop bandwidth, flux estimator time constant and PLL PI bandwidth (parameters PLLKp and PLLKi) and related equipment.
- If Flx_M is very noisy, check the following: current feedback and V_{dc} feedback related hardware and parameters.
- If Flx_M does not come close to 2048, “Motor Back EMF Constant (K_e)” needs to be adjusted in MCEWizard.
- The PFC parameters in the software package downloaded from myInfineon are optimized for the reference board. So it is not necessary to change them.

2.1.8 Infrared control commissioning

If the open-loop diagnostic and closed loop work correctly, then the infrared control can be tuned.

1. Connect the J2 of main board to J1 of daughter board by cables, as shown in Figure 6. The daughter board can receive remote infrared commands from the control box.
2. Program firmware, parameters file (script function enabled), and script file for remote infrared control by iMOTION™ link. The iMOTION™ link can be removed after programming if you do not want to view the MCE variables' wave or value from MCEDesigner.
3. The attached remote infrared control box is shown in Figure 6. There are only power, and 1, 2, 3, 4, 5 buttons. The power button is to enable or disable controller transmitting. If the controller transmitting is enabled, you can select incrementally different motor speeds with button 1, 2, 3, 4, 5. Button 5 refers to maximum motor speed. The daughter board can remember the last set speed by the control box before power button being disabled or the daughter board power off, so the motor will start at the last-used setting speed when power button is enabled or the daughter board power on.

System and functional description

2.2 Description of the main board functional blocks

2.2.1 EMI filter and surge protection

Figure 21 shows the diagram of the EMI filter and surge protection. The EMI stages consist of two X-capacitors of 22nF respectively, two series Y-capacitors of 3.3 nF and 4.7 nF respectively, and a 22 mH common-mode inductor. The surge protection circuit consists of two stages of MOV, RV1 and RV2; their reverse break down voltage is 470 V.

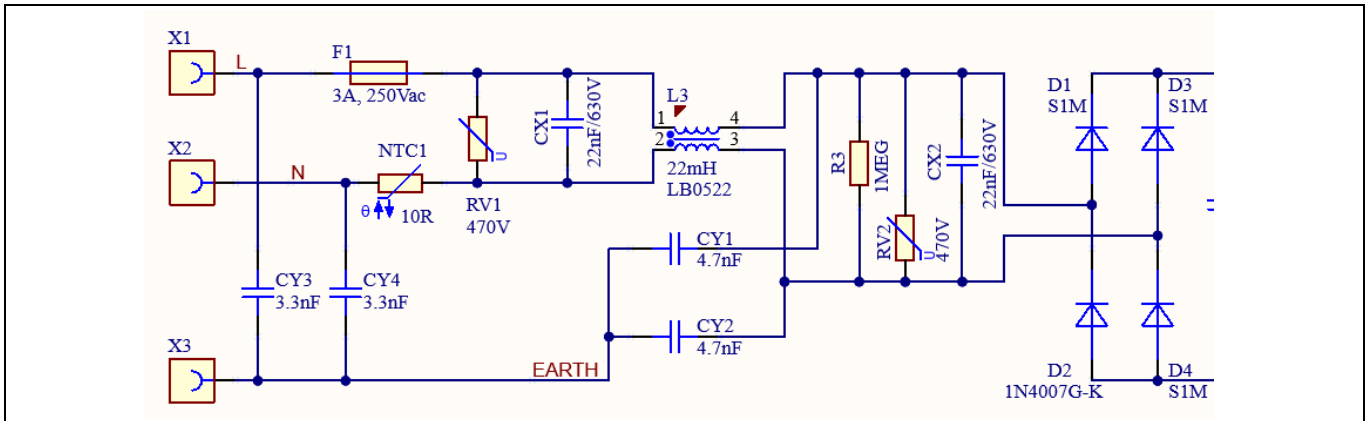

Figure 21 EMI filter and surge protection

2.2.2 DC bus sensing and MCEWizard configuration

Figure 22 shows the detail of the DC bus sensing resistor divider stage.

With the values shown in the figure, the default DC bus-sense voltage results in a range of 0 V to 5 V on the ADC input of the microcontroller (MCU), reflecting an input voltage range from 0 V to 505 V.

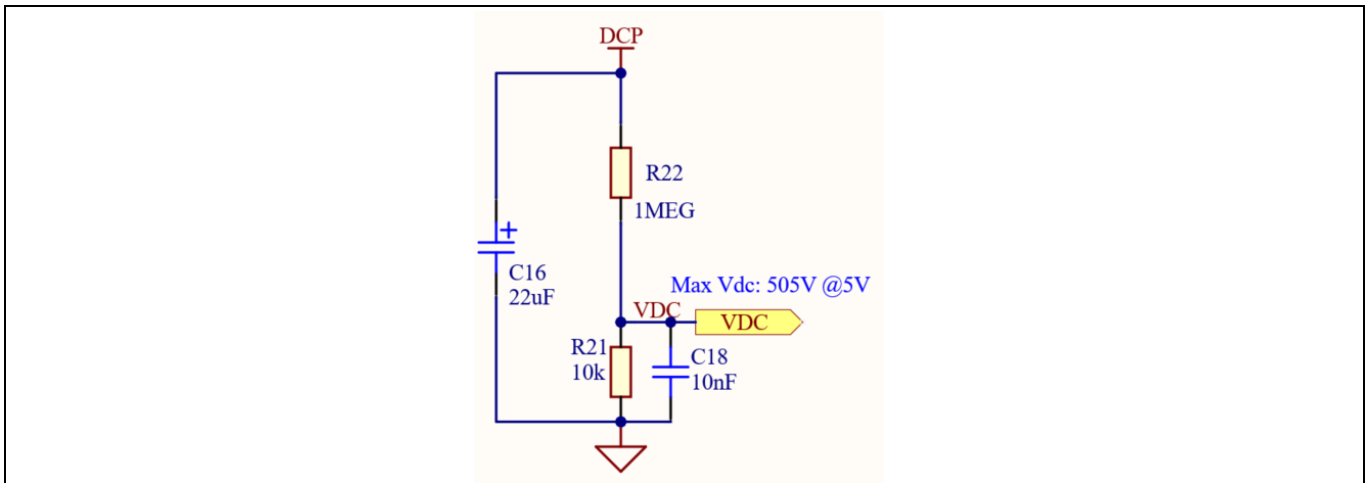

Figure 22 DC bus sensing

The hardware parameters need to be configured in MCEWizard as shown in Figure 23.

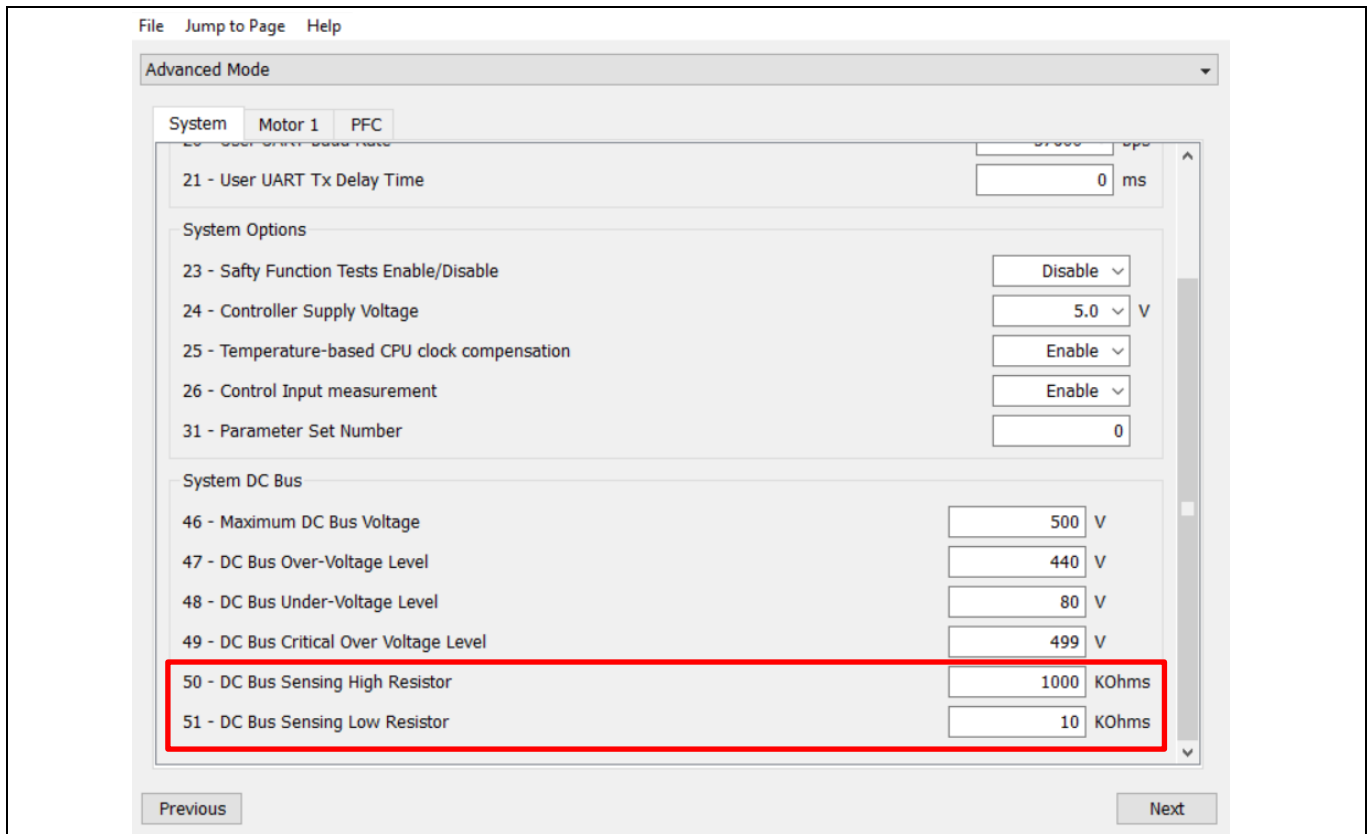

Figure 23 DC bus sensing configuration in MCEWizard

The V_{dc}-sensing stage features a low-pass-filter time constant that can be calculated as:

$$\text{Time constant} = (R22//R21) * C18 = (1 \text{ M}\Omega//10 \text{ k}\Omega) * 10 \text{ nF} = 99 \mu\text{s} \quad \text{Eq. 1}$$

The value of capacitor C18 can be adjusted to improve the V_{dc} noise rejection ratio.

2.2.3 Inverter section

The inverter section is implemented with the latest generation of RC-D2 IGBT in a SOT223 package IKN03N60RC2 or in a DPAK package IKD04N60RC2. The default mounted devices are IKN03N60RC2. 600 V RC-D2 is the successor to the RC-D/DF IGBT. The latest version of the RC-D technology has several improvements compared to its older version: better price, lower power losses, and better controllability over the di/dt to further reduce EMI compared to RC-D/DF. These devices are also robust for high- temperature and high-humidity operations.

Features of IKN03N60RC2 and IKD04N60RC2:

- Very tight parameter distribution
- Operating range of 1 to 20 kHz
- Maximum junction temperature of 175°C
- Short-circuit capability of 3 μs
- Best-in-class current versus package size performance
- Qualified according to JEDEC for target applications
- Robust design for high-humidity operation
- Pb-free lead plating; RoHS compliant
- Complete product spectrum and PSpice Models

Figure 24 shows the diagram of the inverter and peripheral circuit.

System and functional description

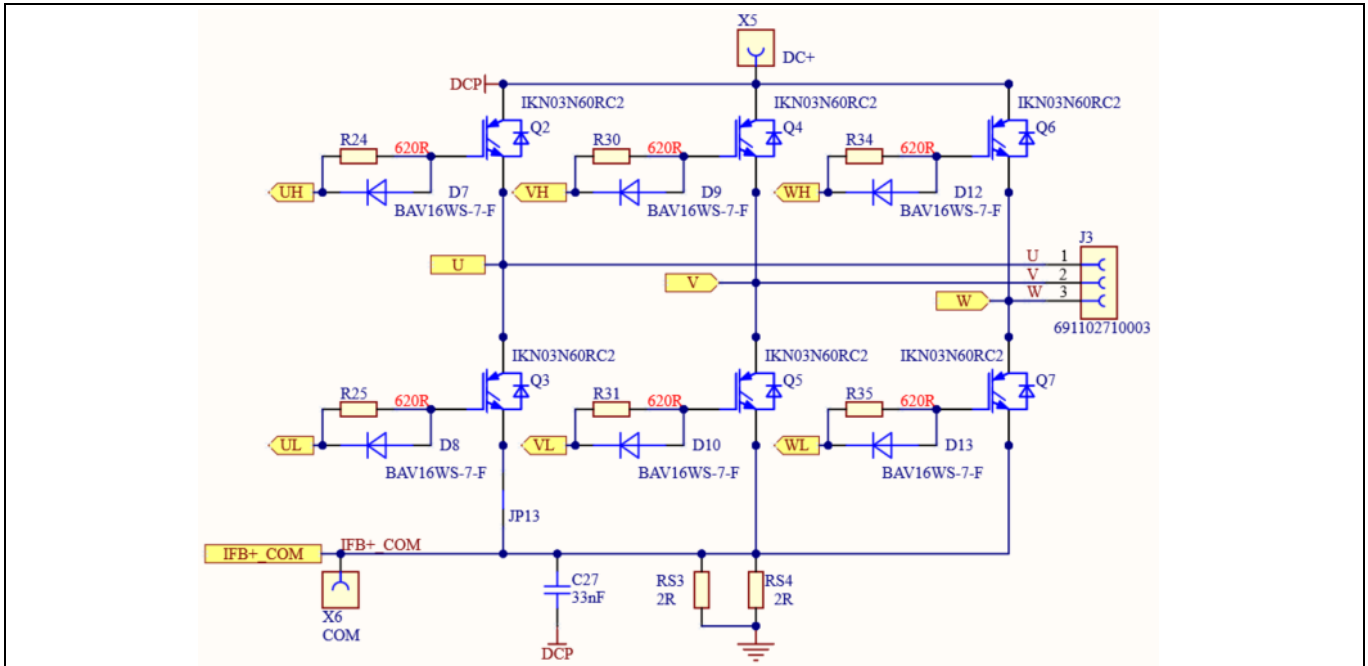

Figure 24 The inverter and peripheral circuit

2.2.4 Motor current sensing and overcurrent protection

2.2.4.1 Motor current sensing

The motor current sensing on this board uses only a RC network for operational gain, bias and low-pass filter to minimize the cost. No additional operational amplifier is needed.

With reference to Figure 25, you can derive the following equation by applying the principle of Kirchhoff's voltage law, assuming that the MCU analog-to-digital converter (ADC) input port has an infinite impedance.

$$V_{ADC} = \frac{(V_{CC} - V_{shunt})}{R_1 + R_2} * R_1 + V_{shunt} \tag{Eq. 2}$$

The equation can thus be adjusted as shown:

$$V_{ADC} = \frac{R_2 * V_{shunt}}{R_1 + R_2} + \frac{R_1 * V_{CC}}{R_1 + R_2} \tag{Eq. 3}$$

Since the impedance of the RC network is much larger than the R_{shunt} , it follows that:

$$V_{shunt} = I_{shunt} * R_{shunt} \tag{Eq. 4}$$

As a consequence, V_{ADC} can then be written as:

$$V_{ADC} = \frac{R_2}{R_1 + R_2} * R_{shunt} * I_{shunt} + \frac{R_1 * V_{CC}}{R_1 + R_2} \tag{Eq. 5}$$

Where $\frac{R_1 * V_{CC}}{R_1 + R_2}$ is the offset, and the gain of the shunt current is $\frac{R_2}{R_1 + R_2} * R_{shunt}$.

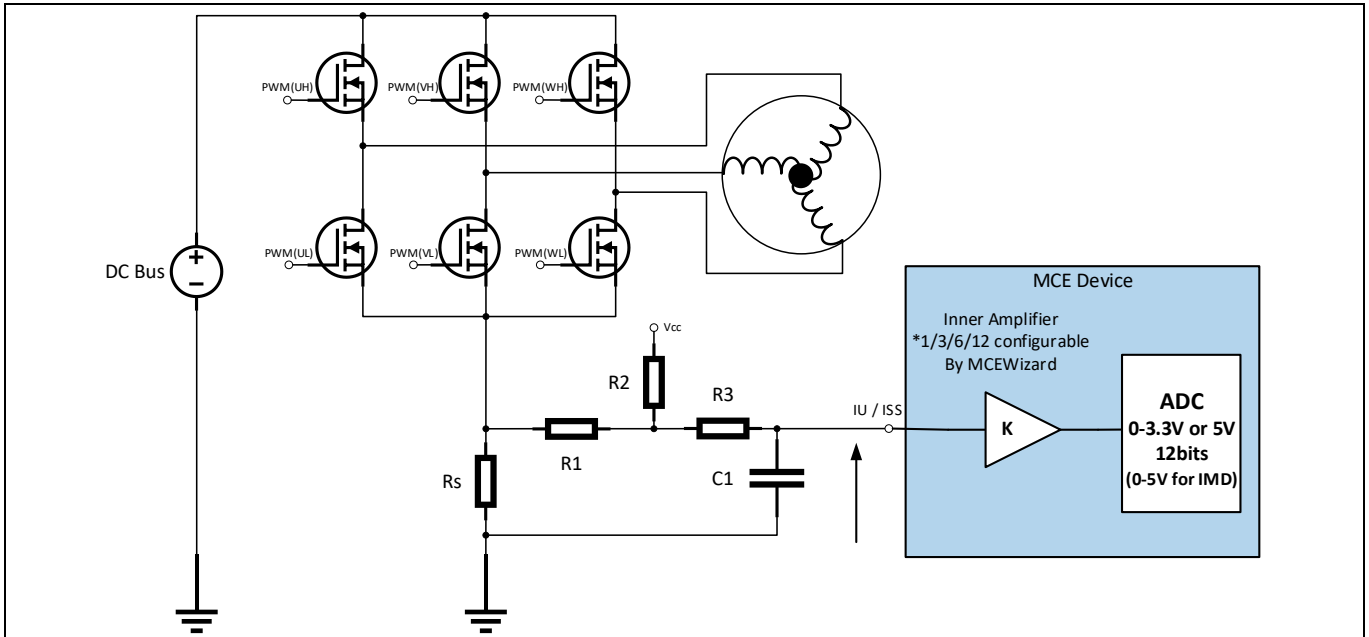

Figure 25 Motor current-sensing topology

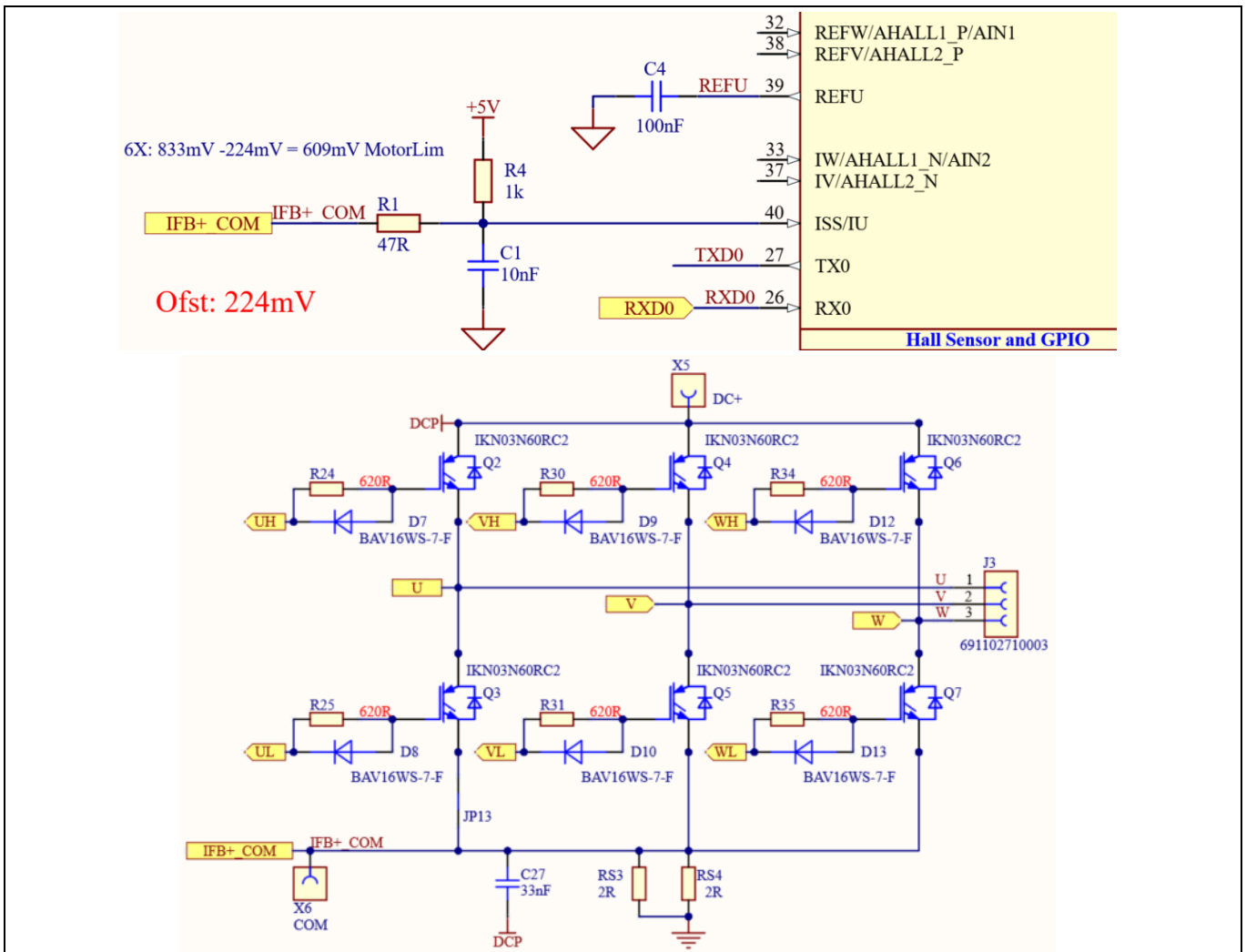

Figure 26 Motor current-sensing circuit on the board

REF-SHA35WRC2SYS user guide

High voltage ceiling fan reference design

System and functional description

As an example in Figure 26, this board has the following values: $R_1 = R_1 = 47 \Omega$, $R_2 = R_4 = 1 \text{ k}\Omega$, $R_s = R_{S3}/R_{S4} = 1 \Omega$, $V_{cc} = 5 \text{ V}$. By using the formula in Eq. 5, the offset is 224 mV, and the gain is $\frac{R_2}{R_1 + R_2} * R_{shunt} = 955 \text{ mV/A}$. Because the amplitude attenuation of low-pass filter, the gain needs to be amended to 909 mV/A for MCEWizard configuration.

Note the following points concerning motor current sensing:

- R_1 and R_4 in Figure 26 determine the ADC operational bias for current sensing, which corresponds to the motor regeneration operation range. For applications that do not work with a regenerative braking mode, the bias can be as low as possible to reserve enough ADC range for the drive mode, since the current in the sense resistance always flows in one direction only. In this example, the offset is 224 mV.
- Since the gain of the external RC circuit is less than 1, internal signal amplification is required to increase the current signal acquired with low shunt resistance values. MCE provides an inner current sampling amplifier with *1, *3, *6 and *12 gain selections, which can be configured in the MCEWizard. In this example, the inner current sampling amplifier is *6, so the current sampling range is from 224 mV to 833 mV.
- There is no common mode noise suppression capability without an outer operational amplifier, so the GND network of the PCB needs to be designed very carefully, since any voltage difference between IMD112T's ADC ground and shunt resistor ground will be considered as an "input signal," and will deteriorate the control performance or increase audible noise.

2.2.4.2 Motor overcurrent protection

The motor overcurrent condition can be detected by IMD112T-6F040 with internal comparator as shown in Figure 27.

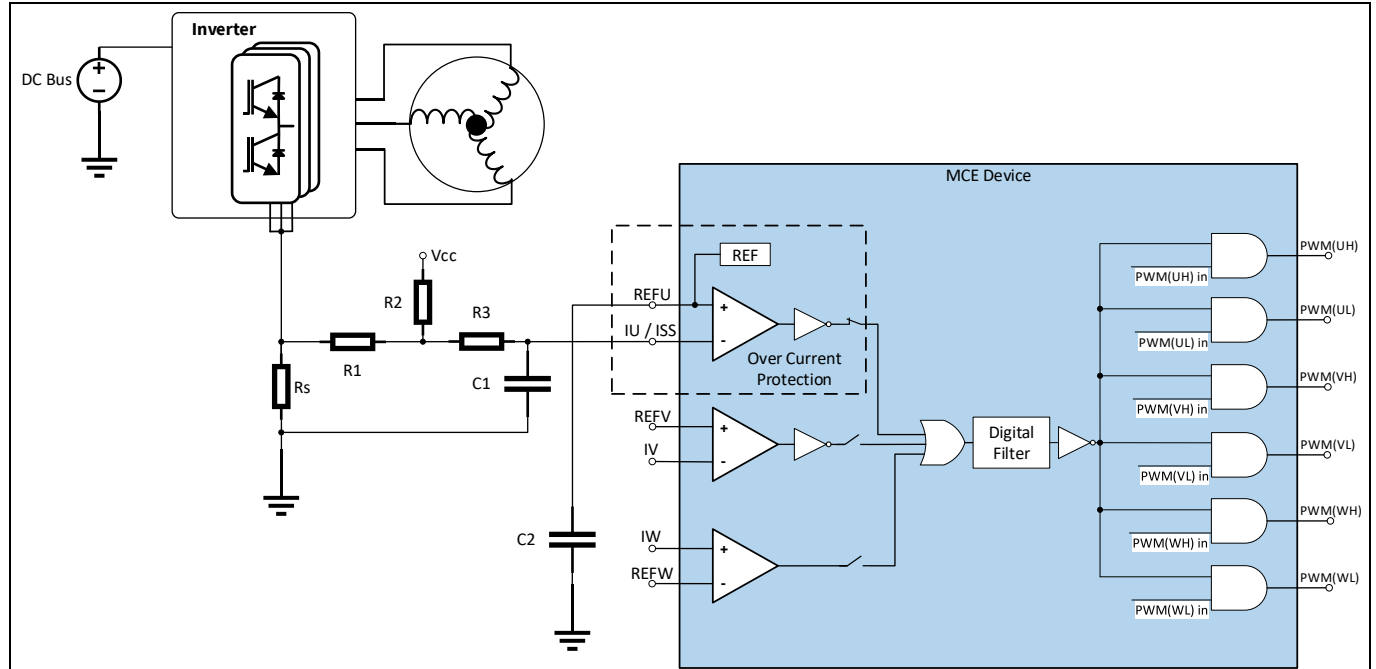

Figure 27 Motor overcurrent protection topology

For more details about motor overcurrent protection (OCP) in the IMD112T, please see the chapter about motor overcurrent protection in the reference material [6].

The internal comparator's reference level is set by the internal digital-to-analog converter (DAC) so the level can be set in the MCEWizard by "Overcurrent Trip Level for Internal Gatekill Comparator" and "Motor1 current

REF-SHA35WRC2SYS user guide

High voltage ceiling fan reference design

System and functional description

input to ADC offset voltage.” The DAC output pin REFU needs to be connected to a capacitor to improve noise rejection (e.g. a 100 nF/25 V capacitor is used on the board as shown in Figure 26).

2.2.5 PFC section

Figure 28 provides the PFC MOSFET driver and peripheral circuit.

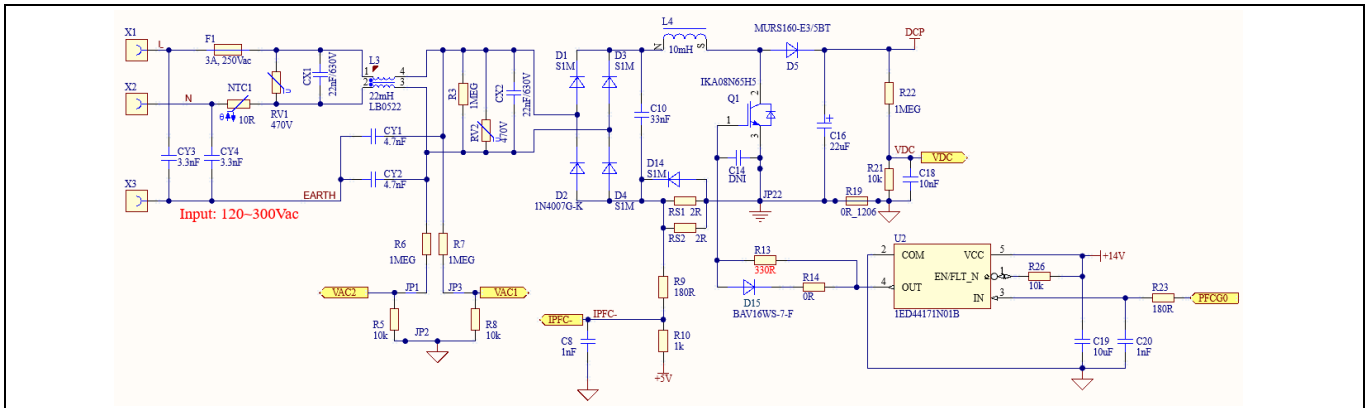

Figure 28 The PFC and peripheral circuit

- An 1ED44171N01B is used for the PFC MOS drive. C14, R13 & R14 select the PFC MOSFET switching du/dt; trade-off between switching noise and power loss is required.
- The bypass diode D14 is designed to bypass the surge current during surge voltage input.
- Two resistors (1% tolerance, 2 Ω, 0.25 W) are used for PFC current sensing.
- 10 mH 0.3 A inductor is used for PFC.
- 650 V DuoPack IGBT with diode IKA0N65H5 is used for the PFC switch. IKA0N65H5 belongs to the high-speed switching series of the fifth generation and has best-in-class efficiency in hard switching and resonant topologies.

2.2.6 PFC current sensing and overcurrent protection

2.2.6.1 PFC current sensing

The PFC current sensing on this board uses an RC network for operational gain, bias and low-pass filter to minimize the cost. No additional operational amplifier is needed. The PFC current-sensing topology is as shown in Figure 29. From the point view of the AD converter, the current input scaling value is the product of the voltage of PFC shunt resistor and the gain of RC network.

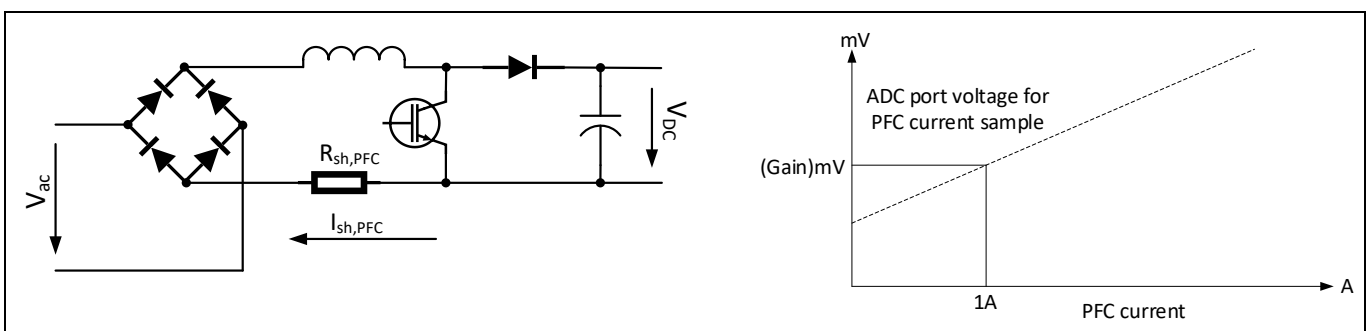

Figure 29 PFC current-sensing topology

REF-SHA35WRC2SYS user guide

High voltage ceiling fan reference design

System and functional description

As shown in Figure 28, two resistors RS1 and RS2 (paralleled) with 1% tolerance, 2 Ω, and 0.25 W are used for the PFC shunt resistor in this reference board. The real AD input voltage can be calculated as below according to the principle of Kirchhoff's voltage law:

$$V_{IPFC_} = \frac{R_{10}}{R_9 + R_{10}} * R_{sh,PFC} * I_{sh,PFC} + \frac{R_9 * V_{CC}}{R_9 + R_{10}} \tag{Eq. 6}$$

$$V_{IPFC_} = \frac{1K\Omega}{180\Omega + 1K\Omega} * 1\Omega * I_{sh,PFC} + \frac{180\Omega * 5V}{180\Omega + 1K\Omega} = 0.847(mV/A) * I_{sh,PFC} + 762 mV$$

So the offset of PFC current sampling is 762 mV, and the gain is 847 mV/A. Because of the amplitude attenuation of the low pass filter, the gain needs to be amended to 806 mV/A for MCEWizard configuration.

Note the following points concerning PFC current sensing:

- Since the gain of the external RC circuit is less than 1, internal signal amplification is required to increase the current signal acquired with low shunt resistance values. MCE provides an inner current sampling amplifier with *1, *3, *6 and *12 gain selections, which can be configured in the MCEWizard. In this example, the inner current sampling amplifier is *6, so the maximum input PFC current-sampling voltage should range from 0 mV to 833 mV (5V/6).
- In this reference board design, the voltage level on the PFC current-sensing resistor is negative with reference to ground, so an ADC operational bias is needed, and PFC current-sensing input polarity should select “inverting” in MCEWizard. R9 and R10 in Figure 28 determine the ADC operational bias for current-sensing; the bias value is 762 mV, so the real AD sampling range for the PFC current-sampling voltage ranges from 0 mV to 762 mV.
- There is no common mode noise suppression capability without an outer operational amplifier, so the GND network of the PCB needs to be designed very carefully. Any voltage difference between IMD112T’s ADC ground and shunt resistor ground will be considered as an “input signal,” and deteriorate the PFC performance and increase harmonic distortion.

2.2.6.2 PFC overcurrent protection

The PFC current-sensing signal feedback to IMD112T-6F040 goes via two pins, the IPFC for PFC control, and the PFCITRIP for PFC overcurrent protection. The PFC overcurrent condition can be detected by IMD112T-6F040 with internal comparator as shown in Figure 27. The overcurrent threshold is designed by the voltage value at input pin PFCREF.

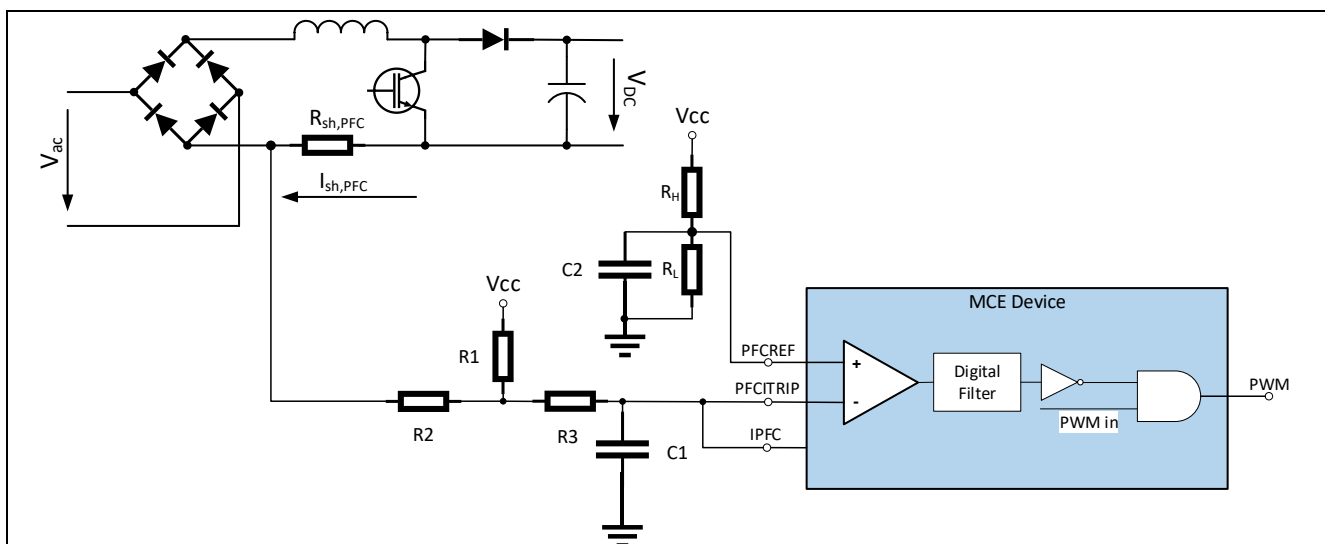

Figure 30 PFC overcurrent protection topology

REF-SHA35WRC2SYS user guide

High voltage ceiling fan reference design

System and functional description

For more details about the PFC overcurrent protection (OCP) in the IMD112T, please refer to the relevant chapter in the reference material [6].

Note the following points concerning PFC overcurrent protection:

- The PFC overcurrent threshold of this board is designed by R15 and R16, and the threshold value is $\frac{150 \Omega}{10 K\Omega + 150 \Omega} * 5 V = 73.6 mV$. That means the PFC overcurrent is $\frac{762 mV - 73.9 mV}{806 mV/A} = 854 mA$.

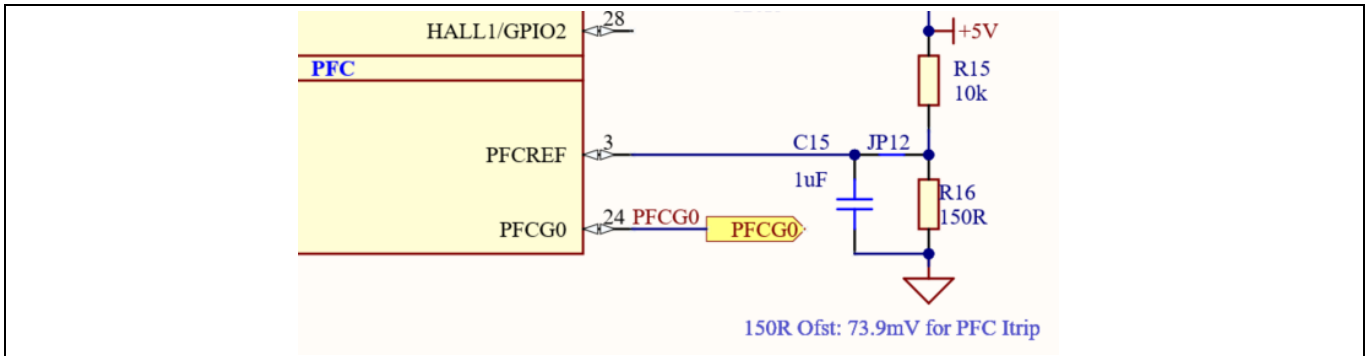

Figure 31 PFC overcurrent threshold design on the board

- The PFC overcurrent has two available modes: latch-off and cycle-by-cycle. This reference board uses cycle-by-cycle mode. For more details about the two PFC overcurrent protection mode, please refer to the relevant section in the reference material [6].

2.2.7 Interface circuit of IMD112T

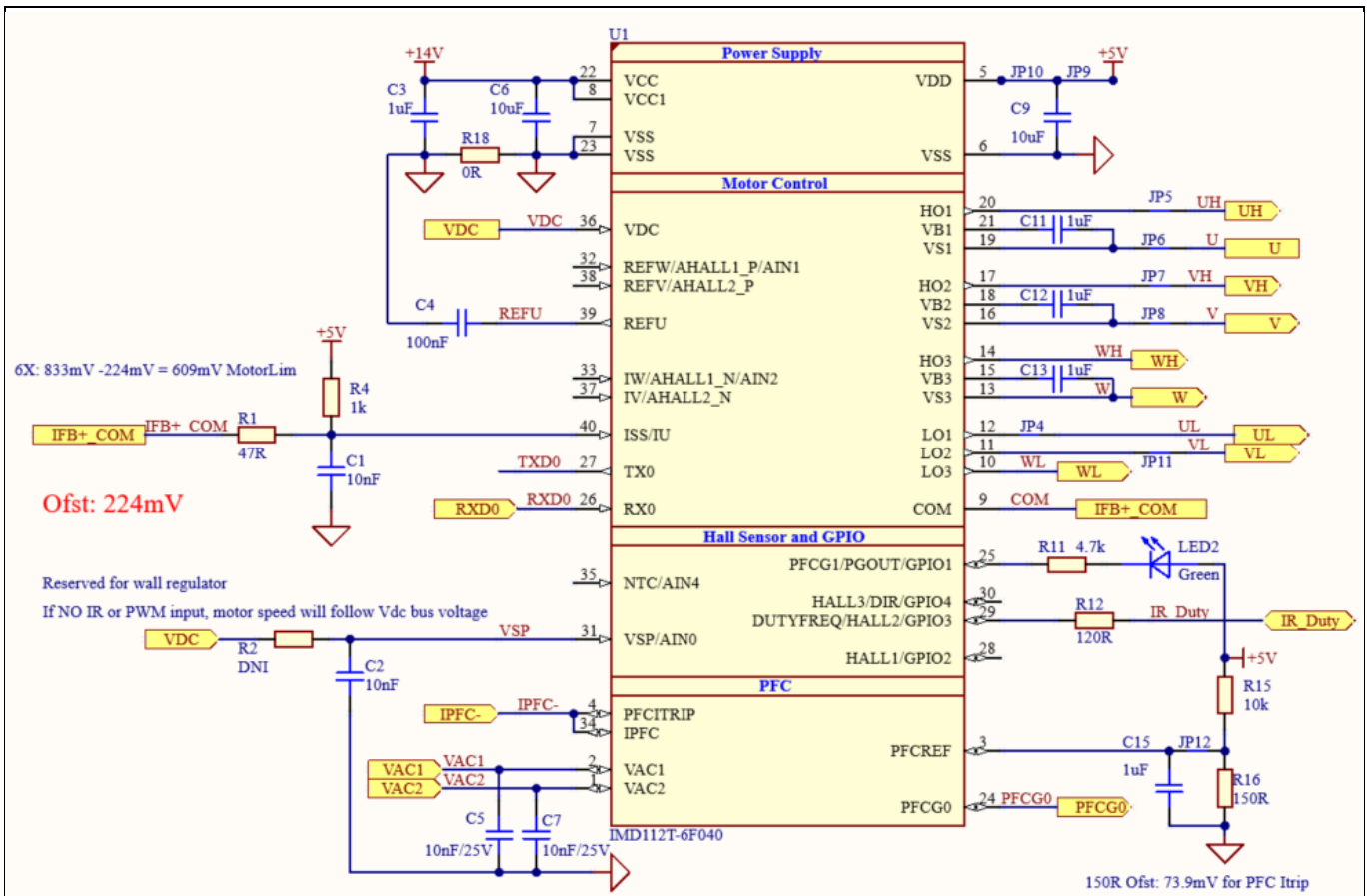

Figure 32 Interface circuit of IMD112T

REF-SHA35WRC2SYS user guide

High voltage ceiling fan reference design

System and functional description

Figure 32 shows the interface circuit of IMD112T:

- The power of IMD112T is 14 V and 5 V power generated by internal LDO in IMD112T.
- UH, UL, VH, VL, WH, WL provide driver for inverting circuit.
- IFB+COM is the motor current sensing signal.
- IPFC- is the PFC current sensing signal.
- VAC1 and VAC2 are AC input voltage sensing signals for PFC.
- PFCG0 is the PFC driver.
- PFCREF is the threshold input of PFC overcurrent protection.
- VDC is the bus voltage sensing signal.
- LED2 is the indicator light of IMD112T power on
- IR_Duty is the duty input signal from the daughter board.
- VSP function is only reserved for a wall regulator and is not enabled in this board.
- RX0 and TX0 are debugging and programing communication channels to MCEDesigner.

2.2.8 Interface circuit to XMC daughter board

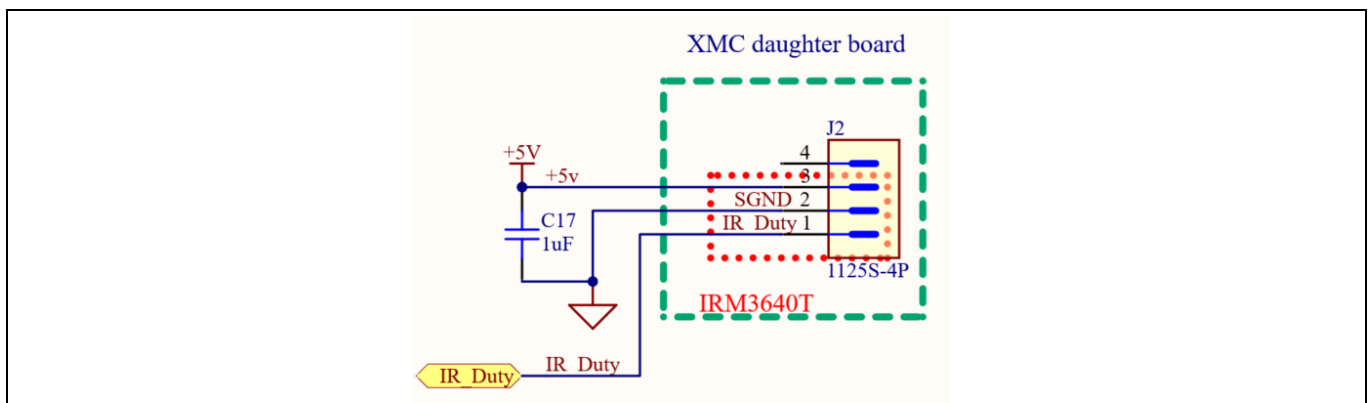

Figure 33 Interface circuit to XMC daughter board

Figure 32 shows the interface circuit to the XMC daughter board. Its function is to power 5 V for the XMC daughter board and receive the duty signal translated from the remote infrared control box.

Note: For the firmware version V1.03.03 of IMD112T, the infrared signal needs to be translated to duty signal by the XMC1100 on the XMC daughter board. The IR_Duty signal is the translated duty signal from the XMC daughter board.

Note: The future updated firmware version of IMD112T, will be able to translate the infrared signal, so the IR-Duty signal can connect to the infrared receiver directly, and does not need to be translated by XMC1100.

System and functional description

2.3 Description of the daughter board functional blocks

This section depicts the XMC daughter board, which receives signals from the remote infrared control box and translates them to duty signal to control the motor speed of the ceiling fan. The communication protocol between infrared control box and daughter board is the standard NEC protocol. All the signals received are decoded in XMC1100 and output duty signals. The XMC1100 can store the last output status when it is power off. So XMC1100 will output last-used duty signal when it is power on again.

2.3.1 Circuit of daughter board

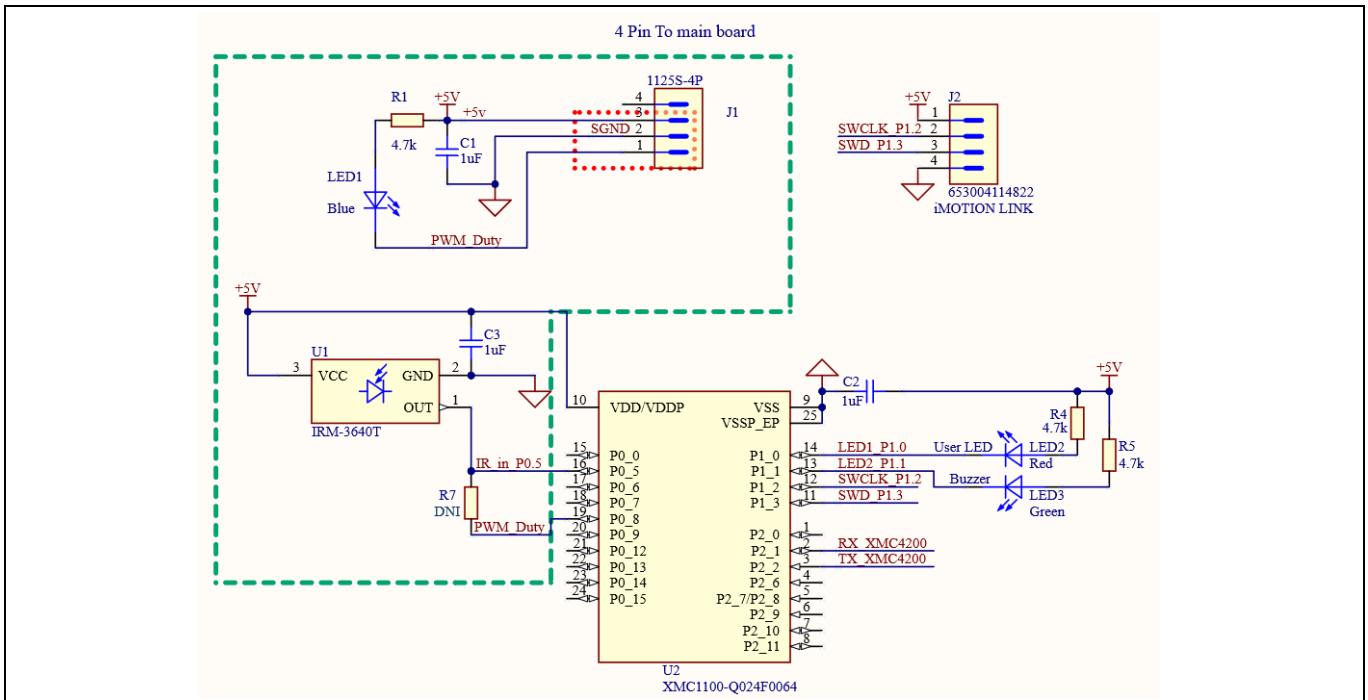

Figure 34 Circuit of daughter board

As shown in Figure 34, the IRM-3640T receives signals from the remote infrared control box, and XMC1100 translates them to duty signals. The LED1 indicates the width of the output duty and becomes brighter as the width narrows. LED2 and LED3 indicate that XMC1100 has received infrared signals, but their logic is contrary. LED2 lights up (is normally off) and LED3 goes off (is normally lit up) when the XMC1100 has received infrared signal.

The J2 is for programming XMC1100, which was programmed before shipment.

Note: The future updated firmware version of IMD112T will be able to translate the infrared signal, so the IR-Duty signal can connect to the infrared receiver directly, and does not need to be translated by XMC1100. Only the components in the green frame need to be mounted. Remember to mount R7, which is not needed in the present application.

2.3.2 Output duty signals versus infrared control box buttons

Figure 35 depicts the output duty signals from the remote infrared control box. When the power button is disabled, the output signal is at high level and all other buttons are inactive. When the power button is enabled, all other buttons on the control box are active. Then you can select button 1 ~ 5 for different motor speed. Please note that all the duty cycle output from daughter board is low level active.

System and functional description

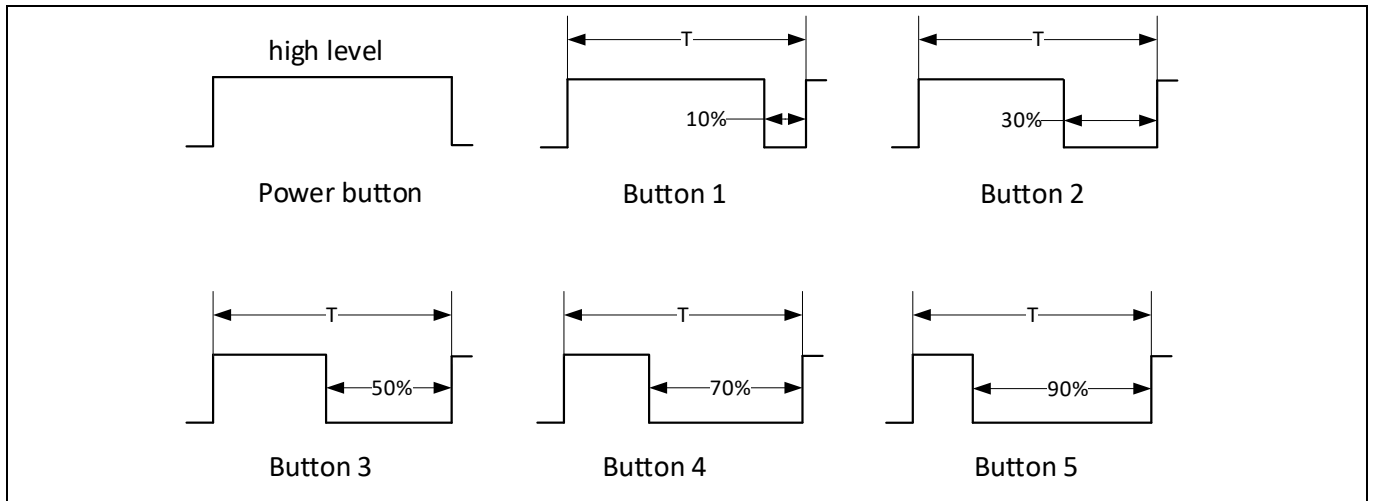

Figure 35 Output duty signals versus infrared control box buttons

2.4 Description of script code

The script code is to control motor and PFC start/stop, and motor target speed according to duty signal from daughter board; it also to control PFC bus target value tracking input voltage and bus target value adjusting based on motor back-EMF.

Figure 36 shows the flow chart of script code and Code Listing 1 shows all the source code of script. There are two tasks: Script_Task0 and Script_Task1. Script_Task0() executes every 5 ms and Script_Task1() executes every 10 ms. Script_Task0() is to get duty signal from the daughter board and output motor target speed value. Script_Task1() is to get the MCE fault, motor real speed, to control motor and PFC start/stop and adjust motor target speed and PFC target DC bus value online.

In Script_Task0_Init(), there is only initialization of status flag sVar_MotorStatus.

In Script_Task0(), the input duty is limited to 0 ~ 1000 counts, representing 0.0% ~ 100.0% duty high level width. The active duty cycle in script need to be subtracted by 1000 counts for input duty is low level active. The input duty is limited from 5% to 95%, the motor and PFC will stop if duty signal is over this limitation. The duty counts multiplied 16 represent approximate motor target speed, because 16384 counts represents max speed set in MCEward. For the motor tested in this article, the max active motor speed is limited to 14386 counts in script.

In Script_Task1_Init(), all the control variables are initialized here. The PLLKp and PLLKi are especially for the motor tested in this article. They will impact motor harmonic current. As usually, the default value of PLLKp and PLLKi are ok, so they don't have to redefine here for customer motor. The initial value of TargetSpeed and PFC_TargetVolt usually need to be tuned based on customer motor for perfect start performance.

In Script_Task1(), first, read the fault information of MCE (motor control engine) and PFC. Second, read input voltage value and filter it, then generate tracking bus voltage target for PFC with adding 10V. Third, read motor real speed absolute value. Fourth, enter into state machine control if the received motor target speed is bigger than 1000 counts and there is no MCE and PFC fault.

When sVar_MotorStatus = 0, start motor with the initial target speed.

When sVar_MotorStatus = 1 and real motor speed over 1200 counts, start PFC with the initial bus target voltage.

When sVar_MotorStatus = 2, first adjust the motor target speed according to the input duty signal. Second, adjust the bus target voltage according to the real motor speed (motor back-EMF) and input voltage, and limit the max bus target voltage to 3244 counts (400 V). In the bus target voltage process, usually all the coefficients need to be tuned based on customer motor, the principle is to ensure that the motor speed can reach the target speed, not limited by back-EMF for bus voltage is not enough and the bus target voltage is as lower as possible to reduce power loss.

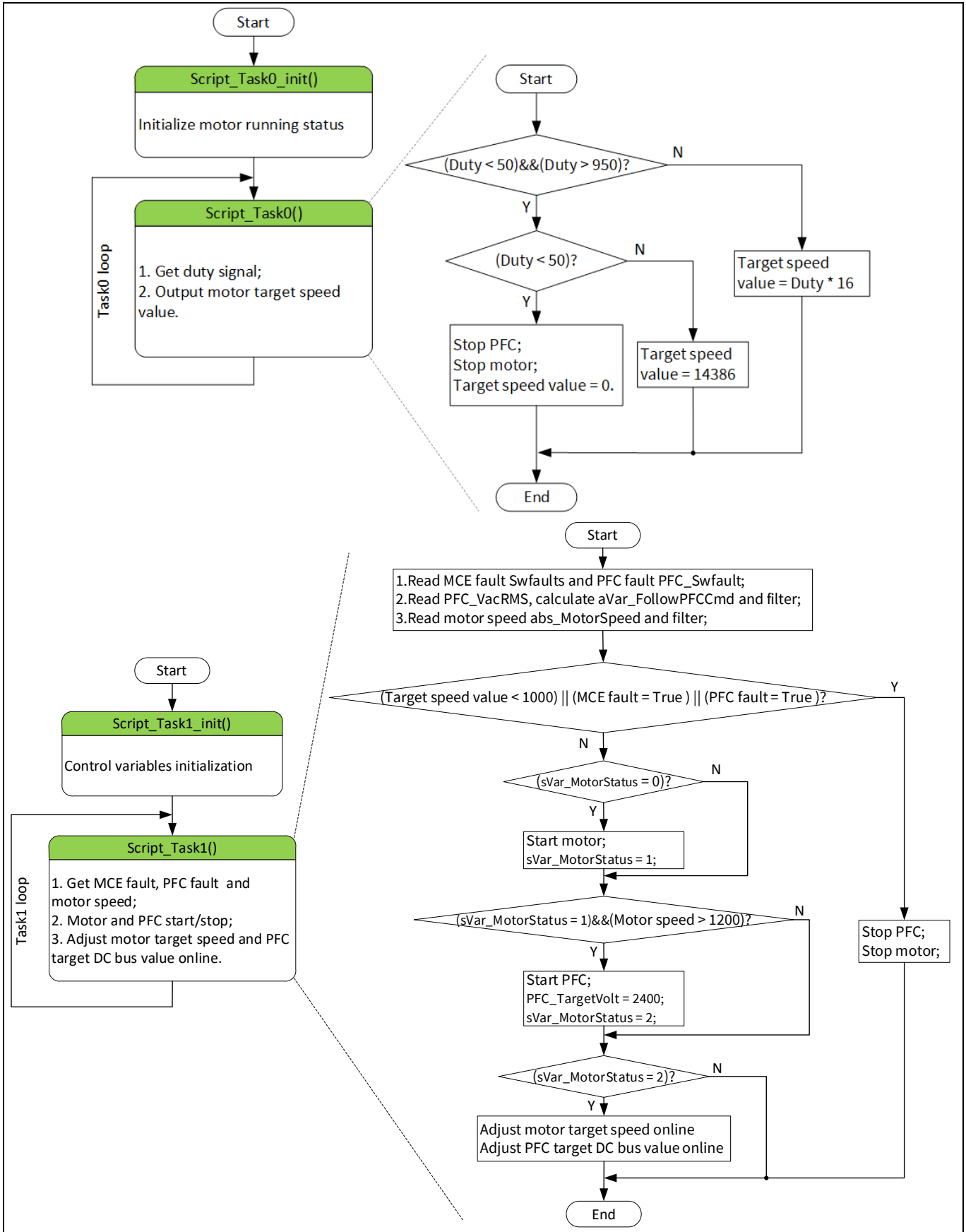

Figure 36 Flow chart of script code

Code Listing 1 Script code for remote infrared control

```
001 #SET SCRIPT_USER_VERSION (1.00) /*Script version value should be 255.255*/
002 #SET SCRIPT_TASK0_EXECUTION_PERIOD (5) /*Script execution time for Task0
in mS, maximum value 65535*/
003 #SET SCRIPT_TASK1_EXECUTION_PERIOD (1) /*Script execution time for Task1
in 10mS, maximum value 65535*/
004 #SET SCRIPT_START_COMMAND (0x3) /* Start command, Task0 : Bit0, Task1 : Bit1;
if bit is set, script executes after init */
005 #SET SCRIPT_TASK0_EXECUTION_STEP (10) /* Script Task0 step, This defines
number of lines to be executed every 1mS*/
006 #SET SCRIPT_TASK1_EXECUTION_STEP (30) /* Script Task1 step, This defines
number of lines to be executed every 10mS*/
007
008 /*****
*****/
009
010 int sVar_MotorStatus;
011 int sVar_RdDuty;
012 int sVar_RcCmdSpd;
013
014 int sVar_AbsFanSpd;
015 int sVar_MCEErrorCode;
016 int sVar_PFCErrorCode;
017 int sVar_VacRMS_Flt;
018 int sVar_FollowPFCCmd;
019
020 int sVar_temp0;
021 int sVar_temp1;
022
023 /*
024 Read Dutycycle about 10% ~ 90% (total 664us)
025 Ton is 66us,199us,332us,465us,598us
026 */
027
028 /*Task0 init function*/
029 Script_Task0_init()
030 {
031     sVar_MotorStatus = 0;
032 }
033
034 Script_Task1_init()
035 {
036     sVar_MotorStatus = 0;
037     PllKp = 600;
038     PllKi = 100;
039     Vd_Ext=0;
040     Vq_Ext=0;
041     AngleSelect =2;
042     CtrlModeSelect =2;
043     Command = 0;
044     PFC_Command = 0;
045
046     TargetSpeed= 1600; //initial motor speed 40 rpm
047     PFC_TargetVolt = 2400; //initial PFC target voltage 296V
048 }
049
050 /*****Task0 script function*****/
051 /*****RC commnad read and deal 5ms run*****/
052 Script_Task0()
053 {
```

Code Listing 1 Script code for remote infrared control

```
054 int ControlDutyTemp;
055 // Read ControlDuty: 100~900cts for 10%~90% dutycycle,update every 10 ms
056 // Input low level active
057 ControlDutyTemp = 1000 - ControlDuty;
058 if(ControlDutyTemp < 0)
059 {
060 ControlDutyTemp = 0;
061 }
062 if(ControlDutyTemp > 1000)
063 {
064 ControlDutyTemp = 1000;
065 }
066 sVar_RdDuty = (ControlDutyTemp + 7 * sVar_RdDuty + 4)>>3; //LPF for 1/8
067
068 //Stop or Wrong input, keep Stop and fix SpdCmd = 0
069 if((sVar_RdDuty > 950)|| (sVar_RdDuty < 50))
070 {
071 sVar_RcCmdSpd = 0;
072 Command = 0;
073 PFC_Command = 0;
074 }
075 else
076 {
077 sVar_RcCmdSpd = sVar_RdDuty * 16; //Transfer Dutycycle to speed count
078 // (10% --> 1600cts)
079 if(sVar_RcCmdSpd > 14386)
080 {
081 sVar_RcCmdSpd = 14386; //limit motor speed to max speed 360 rpm
082 }
083 }
084 }
085
086 /*****Task1 script function*****/
087 /*****10ms run*****/
088 Script_Task1()
089 {
090 //*****Read and LPF*****/
091 //Read MCE and PFC fault
092 sVar_ErrorCode = SwFaults;
093 sVar_PFCErrorCode = PFC_SwFaults;
094
095 // LPF for Vac RMS
096 sVar_VacRMS_Flt = (7*sVar_VacRMS_Flt + PFC_VacRMS + 4)>>3;
097
098 //1.414*32= 45.248 // Vacpeak +10V
099 sVar_FollowPFCCmd = 81 + (sVar_VacRMS_Flt * 45 + 8)>>4;
100
101 // LPF for Fan ABS speed feedback
102 sVar_AbsFanSpd = (7*sVar_AbsFanSpd + abs_MotorSpeed + 4)>>3;
103
104 /*****Motor and PFC control, (0,1,2 state machine)*****/
105 // Stop PWM if CMD is too low or MCE fault
106 if (( sVar_RcCmdSpd < 1000) || (sVar_MCEErrorCode >0) || (sVar_PFCErrorCode
>0))
107 {
108 Command=0;
109 PFC_Command = 0;
110 sVar_MotorStatus = 0;
111 }
```

System and functional description

Code Listing 1 Script code for remote infrared control

```
112     else // Start Motor and update Spd & TargetVolt
113     {
114         if (sVar_MotorStatus ==0) //From STOP to Start
115         {
116             sVar_MotorStatus = 1; //Motor start
117             AngleSelect =2;
118             CtrlModeSelect =2;
119             TargetSpeed = sVar_RcCmdSpd; //Normal Run Speed
120             Command = 1; //Start motor PWM
121         }
122
123         //Start PFC when motor start OK (speed over Minspd)
124         if((sVar_MotorStatus ==1) && (sVar_AbsFanSpd > 1200))
125         {
126             sVar_MotorStatus = 2; //Motor started
127
128             //PFC start with a very low voltage REF to reduce power loss
129             PFC_TargetVolt = 2400;
130
131             //Start PFC PWM
132             PFC_Command=1;
133         }
134
135         //Normal PFC and motor run, update PFC and motor speed command
136         if(sVar_MotorStatus ==2)
137         {
138             TargetSpeed = sVar_RcCmdSpd;
139
140             //360RPM= 14386-->2877-->354V, 16383/5 = 3276 -->404V DCBUS
141             sVar_temp0 = sVar_AbsFanSpd/5;
142
143             if(sVar_temp0 > sVar_FollowPFCCmd)
144             {
145                 //High spd & BEMF, need higher Vdcbus to support motor run
146                 PFC_TargetVolt = sVar_temp0;
147             }
148             else //lower Vdcbus as possible to reduce power loss
149             {
150                 //Low Spd or high Vac input, Vdc tracking Vac peak +10V
151                 PFC_TargetVolt = sVar_FollowPFCCmd;
152             }
153
154             if (PFC_TargetVolt > 3244) //MAX Vdc limit: 400V *8.11 = 3244 cts
155             {
156                 PFC_TargetVolt = 3244;
157             }
158         }
159     }
160 }
161 /*****End of Script*****/
```

3 System design

This section provides the complete details of the schematics, layout and connectors. Please note that the schematics, routing and Gerber files are done in Altium® Designer. Users who are interested in the original project files or pdf files can visit the website www.infineon.com and log-in to myInfineon and download on the board's web page.

3.1 Schematics

The major function blocks are introduced in Section 2.2 and Section 2.3 . Users who are interested in further details can download the design files after logging in to the myInfineon account on the board's web page.

3.2 Layout

3.2.1 Main board layout

The main board is designed in a single layer and has a ring shape, with dimensions of 90 mm (D) × 65 mm (H). The main board is manufactured with a copper thickness of 1 oz. (35 μm).

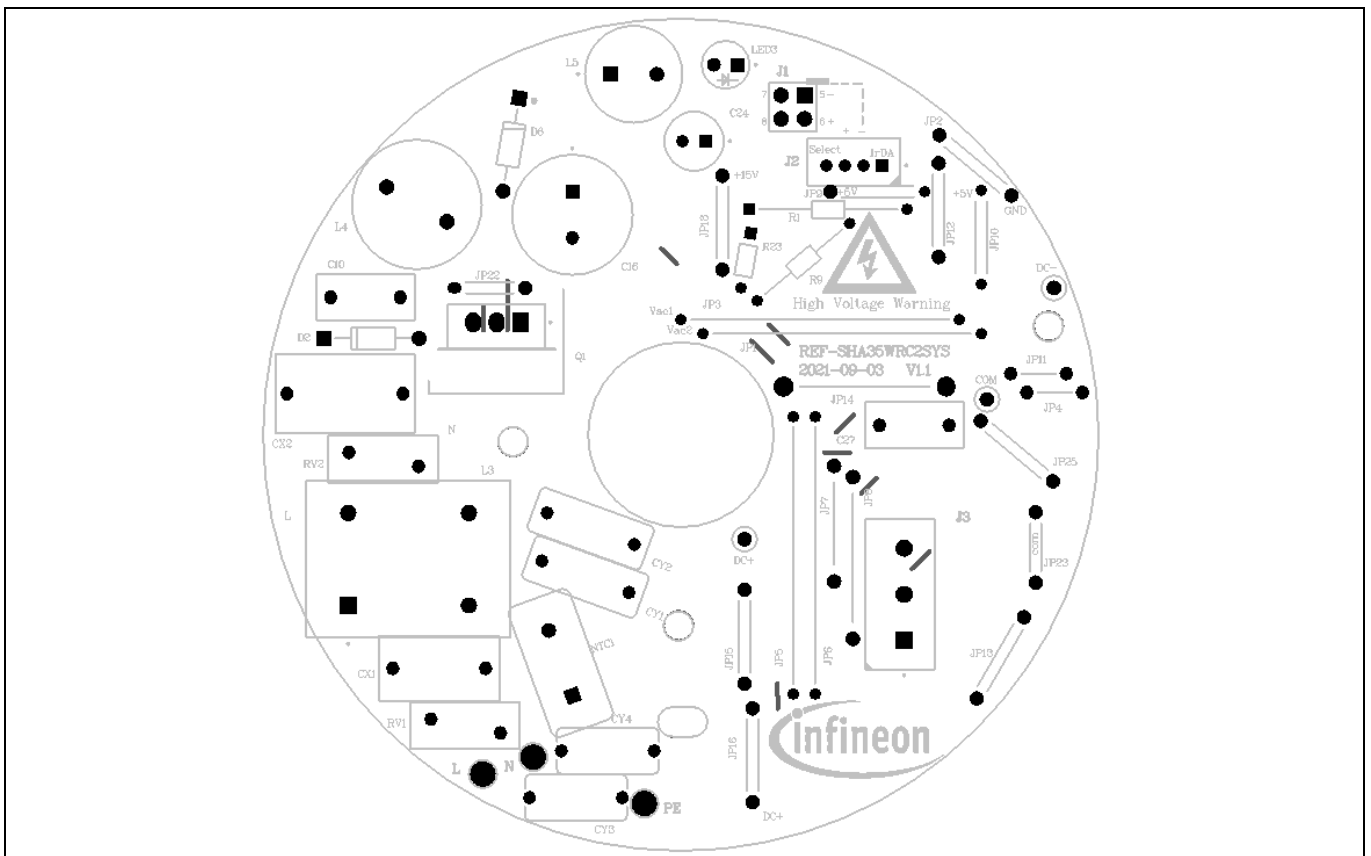

Figure 37 Top assembly print of the main board

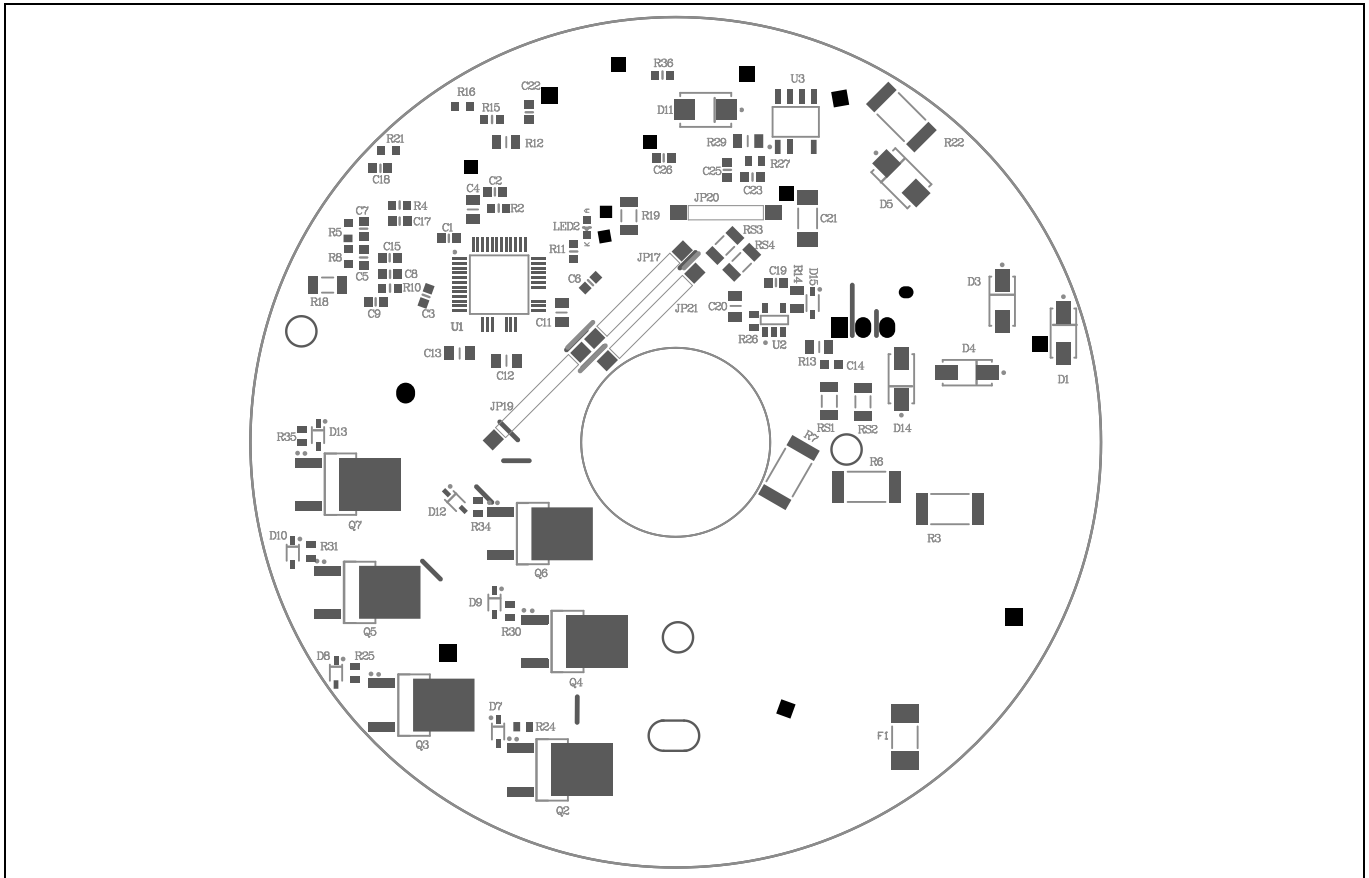

Figure 38 Bottom assembly print of the main board

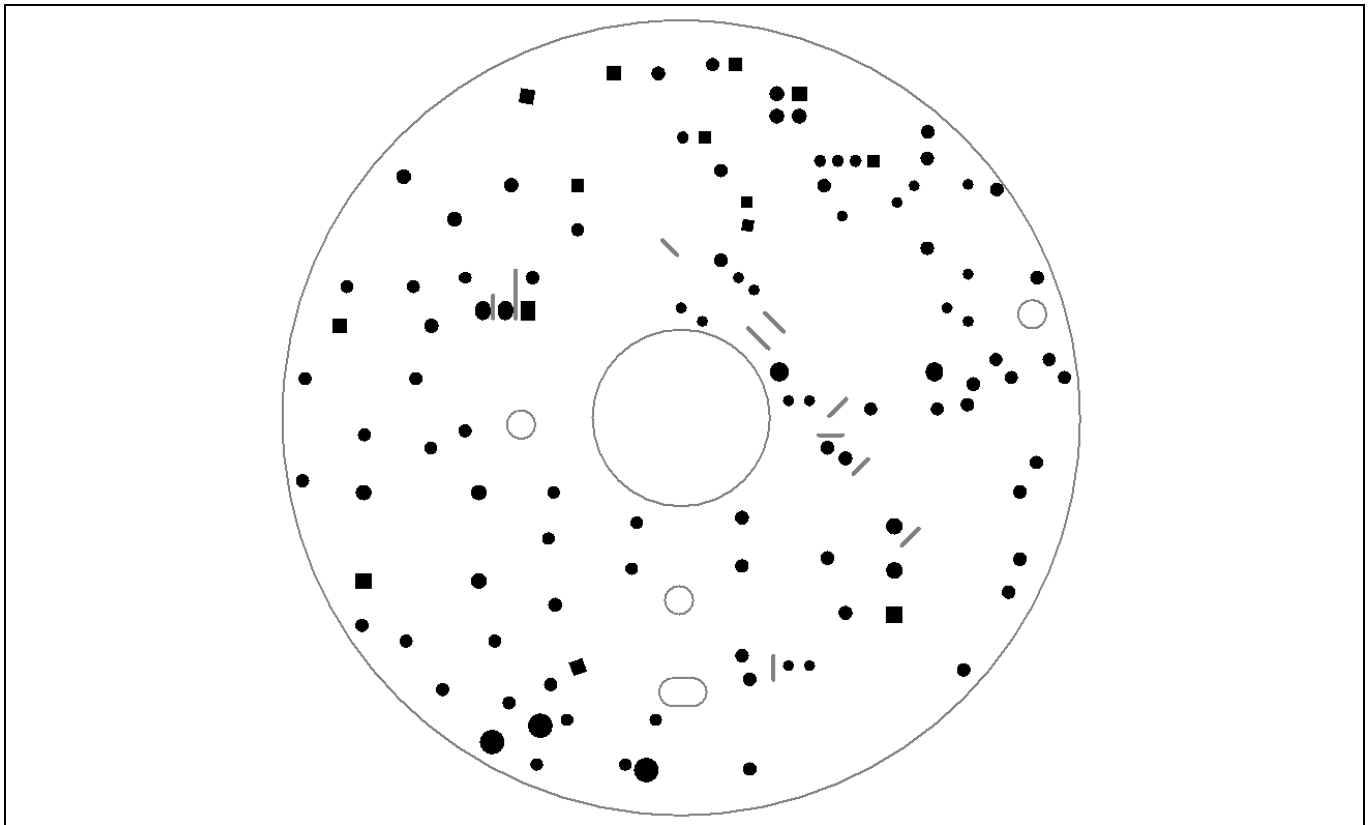

Figure 39 Top layer of the main board

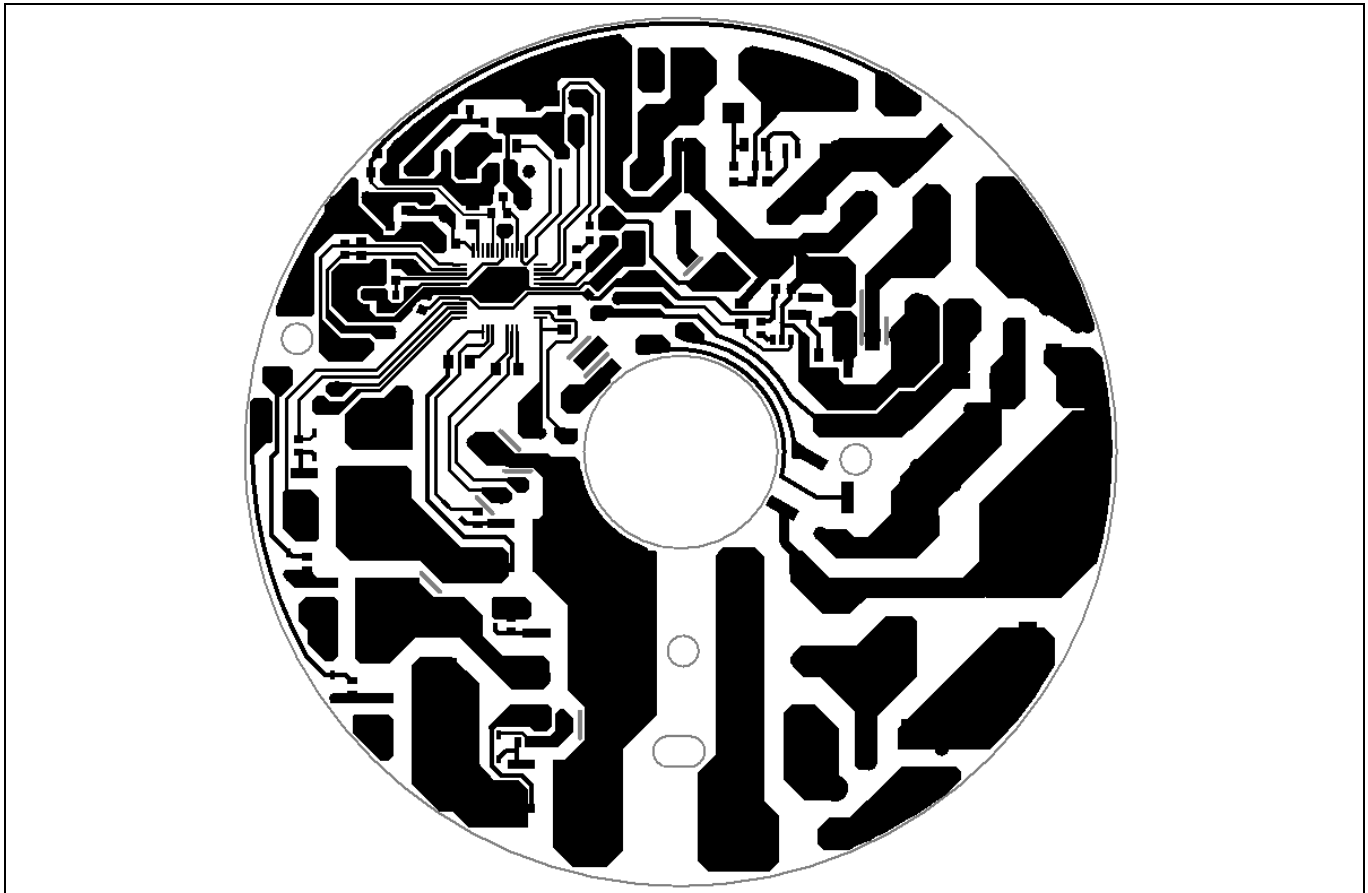

Figure 40 Bottom layer of the main board

3.2.2 Daughter board layout

The daughter board is designed in double layers and has a square shape, with dimensions of 19 mm (L) × 15 mm (W) × 16 mm (H). The daughter board is manufactured with a copper thickness of 1 oz. (35 μm).

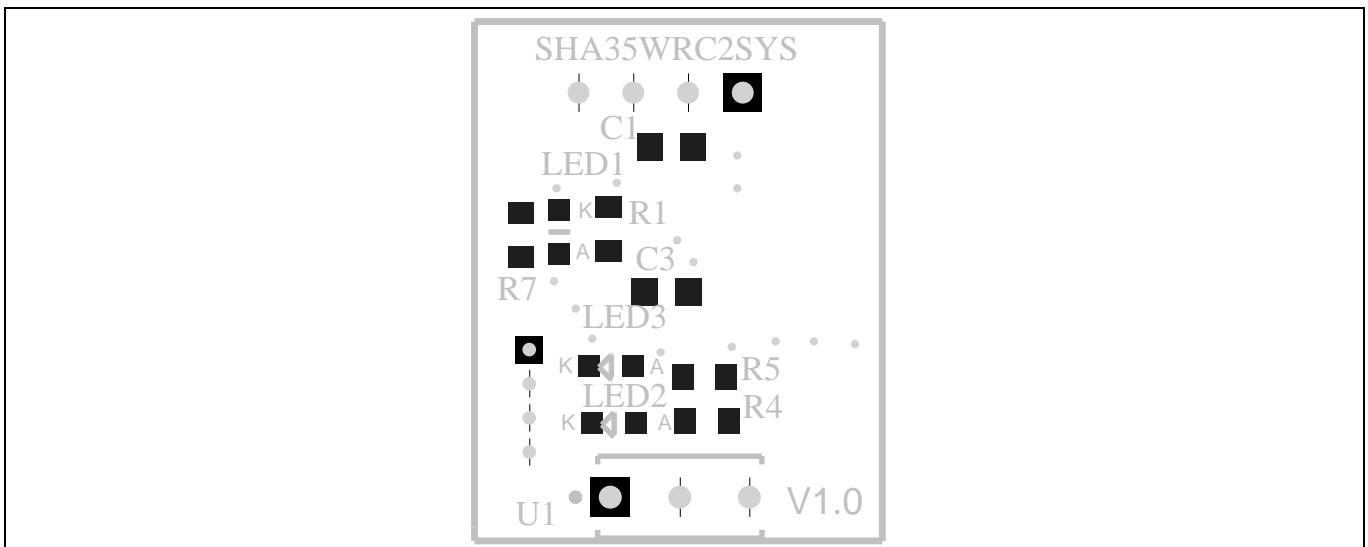

Figure 41 Top assembly print of the daughter board

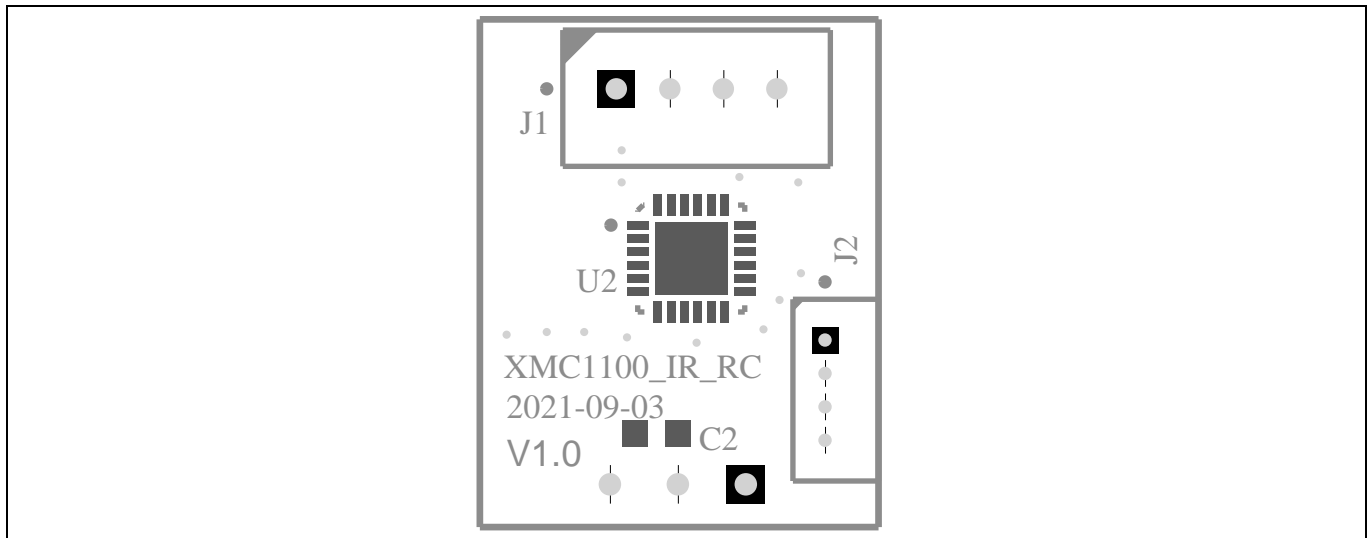

Figure 42 Bottom assembly print of the daughter board

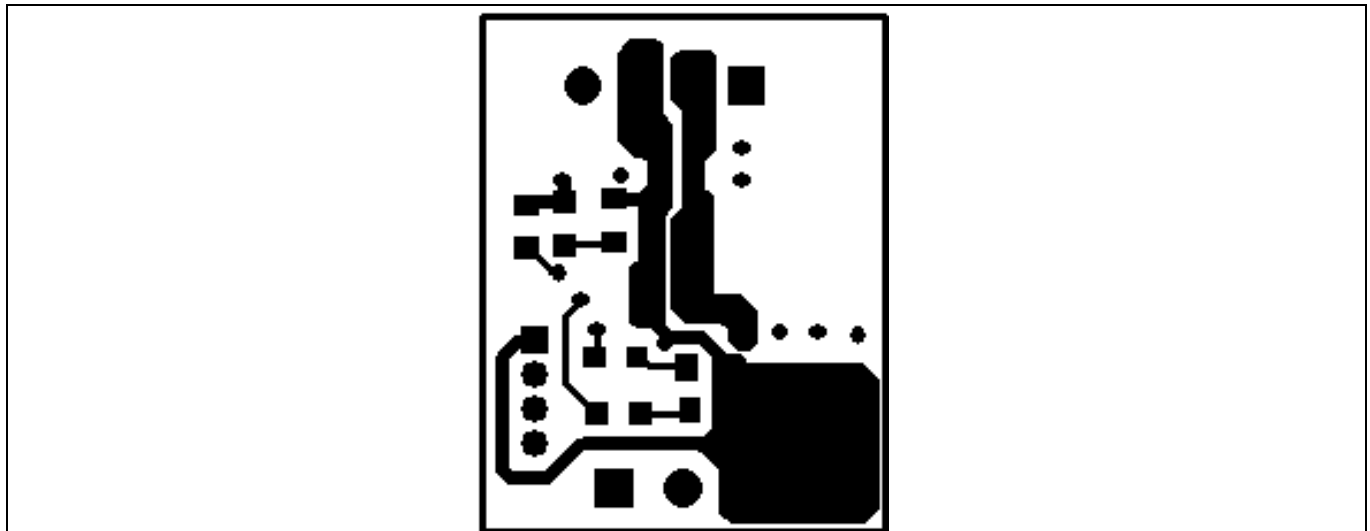

Figure 43 Top layer of the daughter board

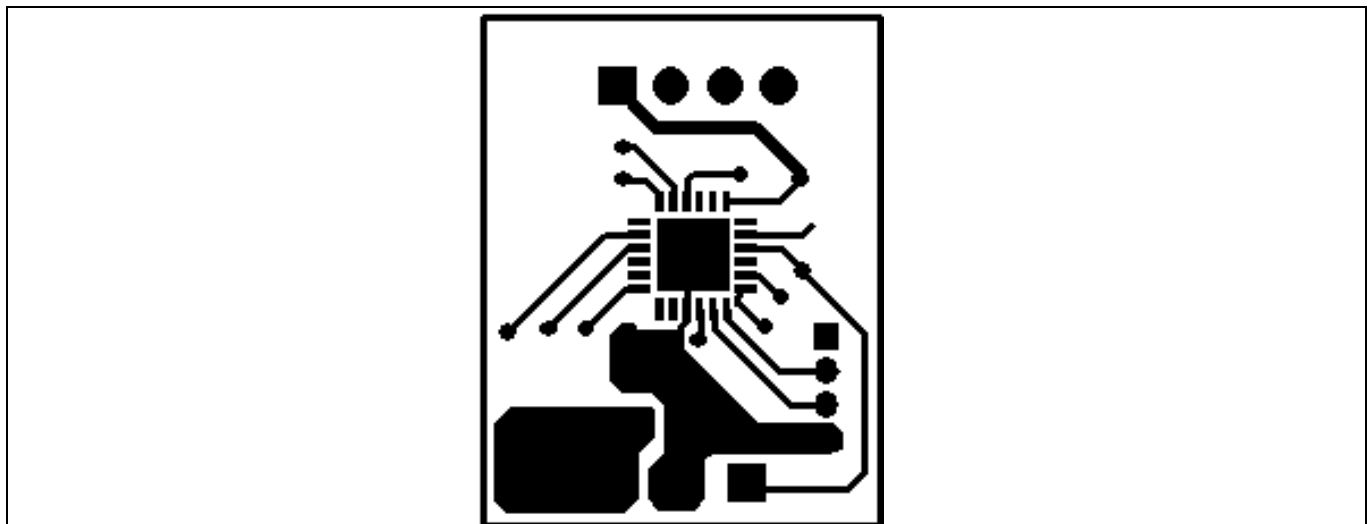

Figure 44 Bottom layer of the daughter board

System design

3.3 Bill of material

The complete bill of material is available on the download section of the Infineon homepage. A log-in is required to download this material.

Table 7 BOM of the most important/critical parts of main board

S. No.	Ref Designator	Description	Manufacturer	Manufacturer P/N
1	C16	CAP/ELCO/22 μ F/450 V/20%/Aluminium electrolytic/-25°C to 105°C/5.00 mm C X 0.60 mm W 13.00 mm Dia X 26.50 mm H	Würth Elektronik	860241478004
2	CX1, CX2	CAP / FILM / 22nF/630V / 630V / 10% / MKP (Metallized Polypropylene) / -40°C to 105°C / 10.00 mm C X 13.00mm L X 4.50 mm W X 10.00 mm H / THT	Würth Elektronik	890334023011CS
3	CY1, CY2	CAP/CERA / 4.7 nF/2.6 kV/20%/Y5U (EIA)/-40°C to 125°C/10.00 mm C X 0.55 mm W 13.00 mm L X 5.00 mm T X 17.00 mm H	Kemet	C961U472MZWDBA7317
4	CY3, CY4	CAP/CERA/3.3 nF/2.6 kV/20%/Y5U (EIA)/-40°C to 125°C/10.00 mm C X 0.55 mm W 11.00 mm L X 5.00 mm T X 15.00 mm H	Kemet	C941U332MZWDBA7317
5	D1, D3, D4, D14	General purpose rectifier	ON Semiconductor	S1M
6	D2	1 A, 50 V – 1000 V glass passivated rectifier	Taiwan Semiconductor	1N4007G-K
7	Q1	High speed 5 IGBT in TRENCHSTOP 5 technology copacked with RAPID1 fast and soft antiparallel diode	Infineon Technologies	IKA08N65H5
8	Q2, Q3, Q4, Q5, Q6, Q7	Cost effective monolithically integrated IGBT with diode	Infineon Technologies	IKN03N60RC2
9	Q2', Q3', Q4', Q5', Q6', Q7'	TRENCHSTOP RC-Series for hard switching applications, VCE 600V, IC 4A	Infineon Technologies	IKD04N60RC2
10	U1	Motor controller with integrated high-voltage gate driver, Integrated script engine for application control customization, thin-film-SOI-technology with negative	Infineon Technologies	IMD112T-6F040

System design

S. No.	Ref Designator	Description	Manufacturer	Manufacturer P/N
		transient robustness, built-in temperature sensor		
11	U2	Single-channel low-side IGBT gate driver IC	Infineon Technologies	1ED44171N01B
12	U3	Lowest component count, energy-efficient off-line switcher IC, 175 mA MDCM in 230 V _{rms}	Power Integrations	LNK305DG

* Q2', Q3', Q4', Q5', Q6', Q7' are alternatives of Q2, Q3, Q4, Q5, Q6, Q7, and Q2, Q3, Q4, Q5, Q6, Q7 are mounted by default.

Table 8 BOM of the most important/critical parts of daughter board

S. No.	Ref Designator	Description	Manufacturer	Manufacturer P/N
1	U1	Remote receiver sensor, 40.0 kHz 14m Through Hole	Everlight	IRM-3640T
2	U2	XMC1000 industrial microcontrollers ARM® Cortex®-M0 32-bit processor core	Infineon Technologies	XMC1100-Q024F0064

3.4 Connector details

3.4.1 Main board connectors

Table 9 X1, X2, X3 AC input connectors

PIN	Label	Function
X1	L	AC line input
X2	N	AC neutral input
X3	EARTH	Earth connector

Table 10 J1- iMOTION™ link connector

PIN	Label	Function
5	GND	Ground
6	+5 V	On board 5 V supply
7	RXD0	MCEDesigner & firmware download
8	TXD0	MCEDesigner & firmware download

System design

Table 11 J2 - Daughter board connector

PIN	Label	Function
1	IR Duty	Duty signal from daughter board
2	GND	Ground
3	+5 V	On board 5 V supply
4	Reserved	Reserved

3.4.2 Daughter board connectors

Table 12 J1 - Main board connector

PIN	Label	Function
1	IR Duty	Duty signal to main board
2	GND	Ground
3	+5 V	On board 5 V supply
4	Reserved	Reserved

Table 13 J2 - XMC1100 programming connector

PIN	Label	Function
1	+5 V	On board 5 V supply
2	SWCLK	SWCLK pin of serial wire debug (SWD)
3	SWD	SWD pin of serial wire debug (SWD)
4	GND	Ground

System performance

4 System performance

4.1 PFC iTHD at rated condition

PFC performance is tested at a rated input voltage of 230 Vrms and output rated power of ceiling fan motor.

Table 14 PFC iTHD at rated condition

Input voltage (Vrms)	Input current (A)	PFC DC target (V)	Input power(W)	Power factor	iTHD(%)
230	0.137	360	33.2~34.0	0.968~0.974	9.33~9.74
Legend	CH1: Iac, CH2: Vac, CH3: Vdc, CH4: IL				
Condition	<ul style="list-style-type: none"> Typical PWM setup for: 60 kHz PFC and 16 kHz motor PWM, 3-phase only mode, motor speed: 360 rpm. PFC control parameters: Kpl= 400, Kxl=600, Kpv= 1500, KxV=30 				

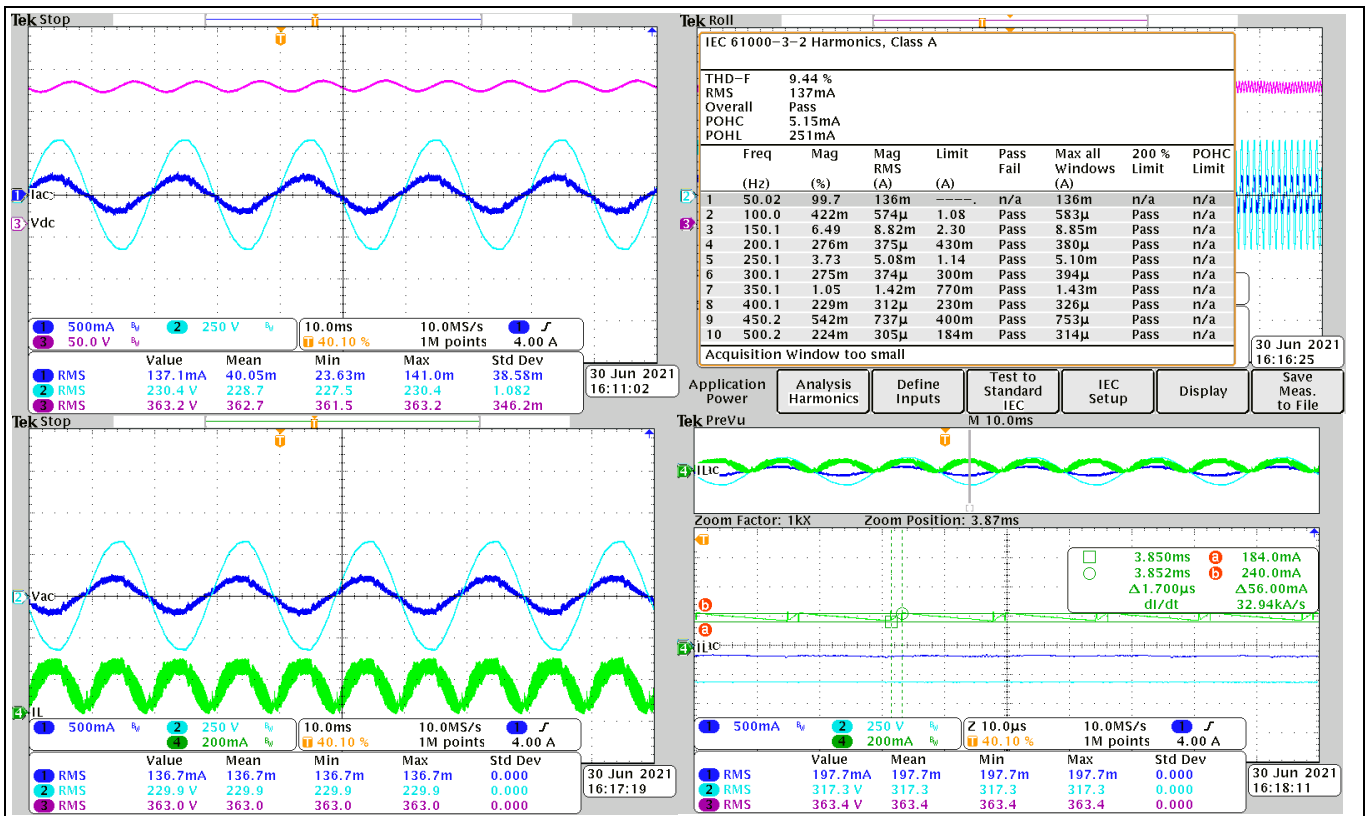

Figure 45 PFC iTHD at rated condition

4.2 Bus voltage ripple

The bus voltage ripple test of input voltage is from 120 Vrms to 230 Vrms.

Table 15 Bus voltage ripple

Input voltage (Vrms)	PFC DC target (V)	Ripple voltage (V)	(%)
120	300	8	2.6
150	300	8	2.6
230	360	7	1.92

REF-SHA35WRC2SYS user guide

High voltage ceiling fan reference design

System performance

Legend	CH1: Iac, CH2: Vac, CH3: Vdc
Condition	● Typical PWM setup for: 60 kHz PFC and 16 kHz motor PWM, 3-phase only mode, motor speed: 360 rpm.

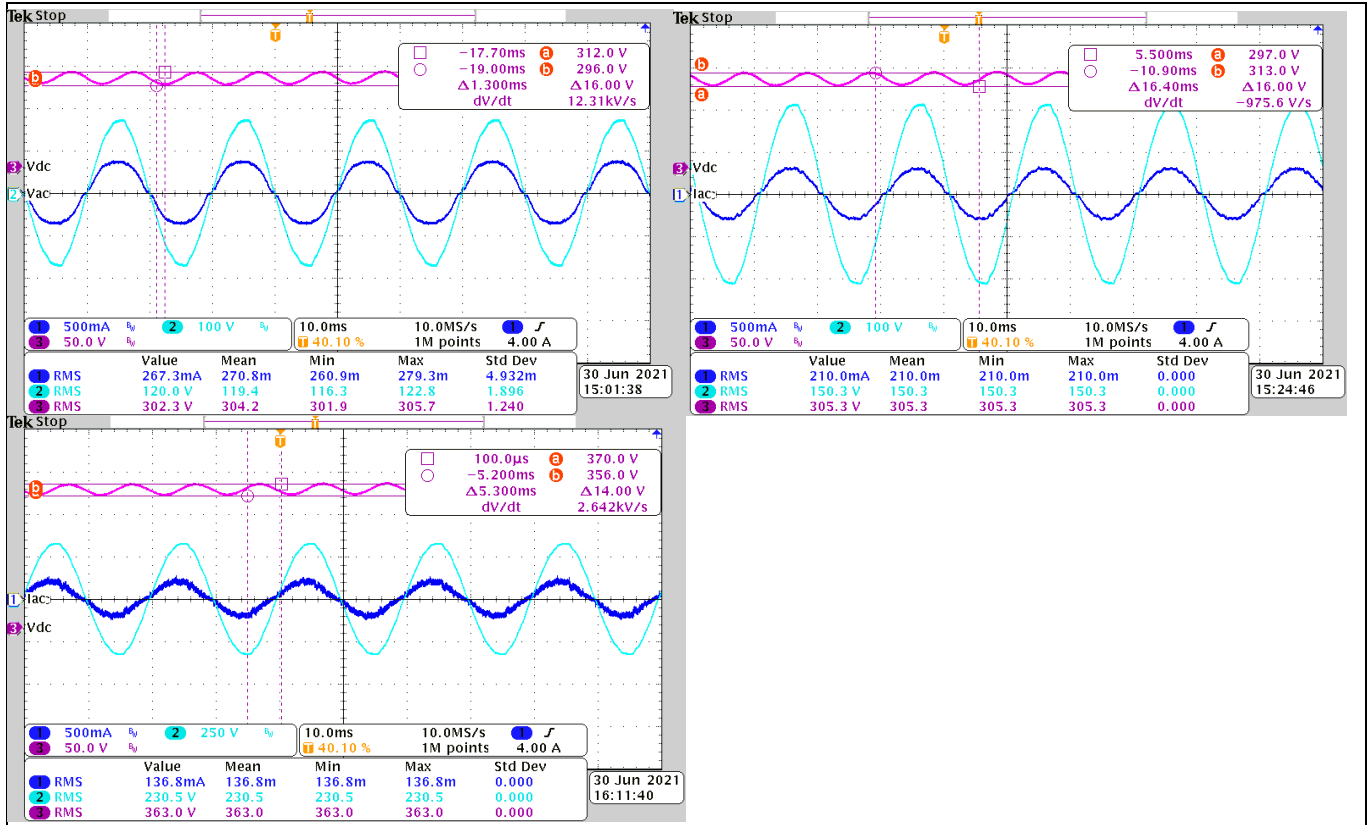

Figure 46 Bus voltage ripple at input voltage: 120 Vrms, 150 Vrms, 230 Vrms,

4.3 PFC IGBT Vce dv/dt performance

Table 16 PFC IGBT Vce dv/dt performance

Input voltage (V)	Input power (W)	Input current (A)	PFC DC target (V)	Power factor	dv/dt of Vce (V/ns)
120	34.2	0.283	260	1	Rising edge: 4.280 Falling edge: 3.344
230	33.9	0.154	360	0.974	Rising edge: 4.306 Faling edge: 2.897

Legend	CH2: Vce, CH3: Vge, CH4: Ic
Condition	● Typical PWM setup for: 60 kHz PFC and 16 kHz motor PWM, 3-phase only mode, motor speed: 360 rpm.

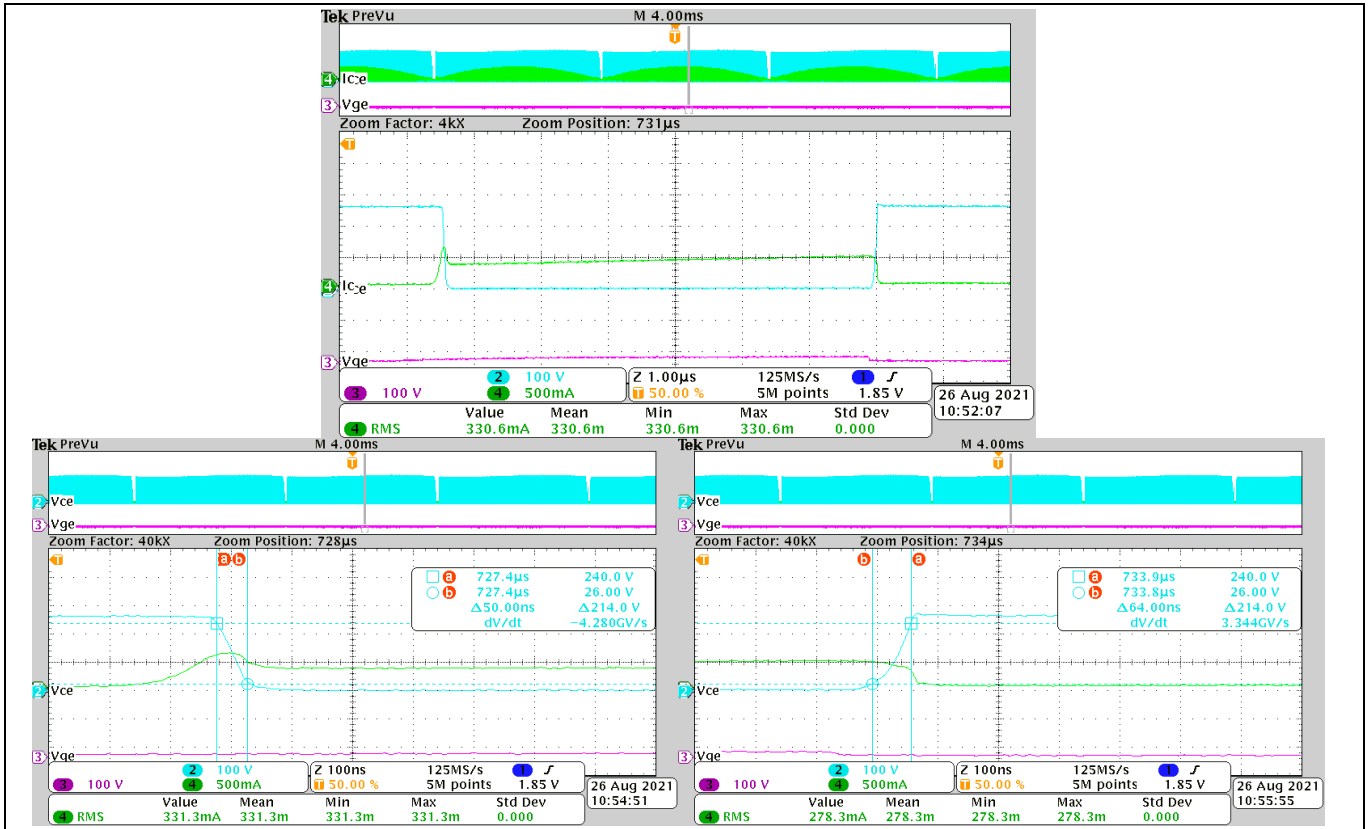

Figure 47 PFC IGBT Vce dv/dt performance at input voltage = 120 V

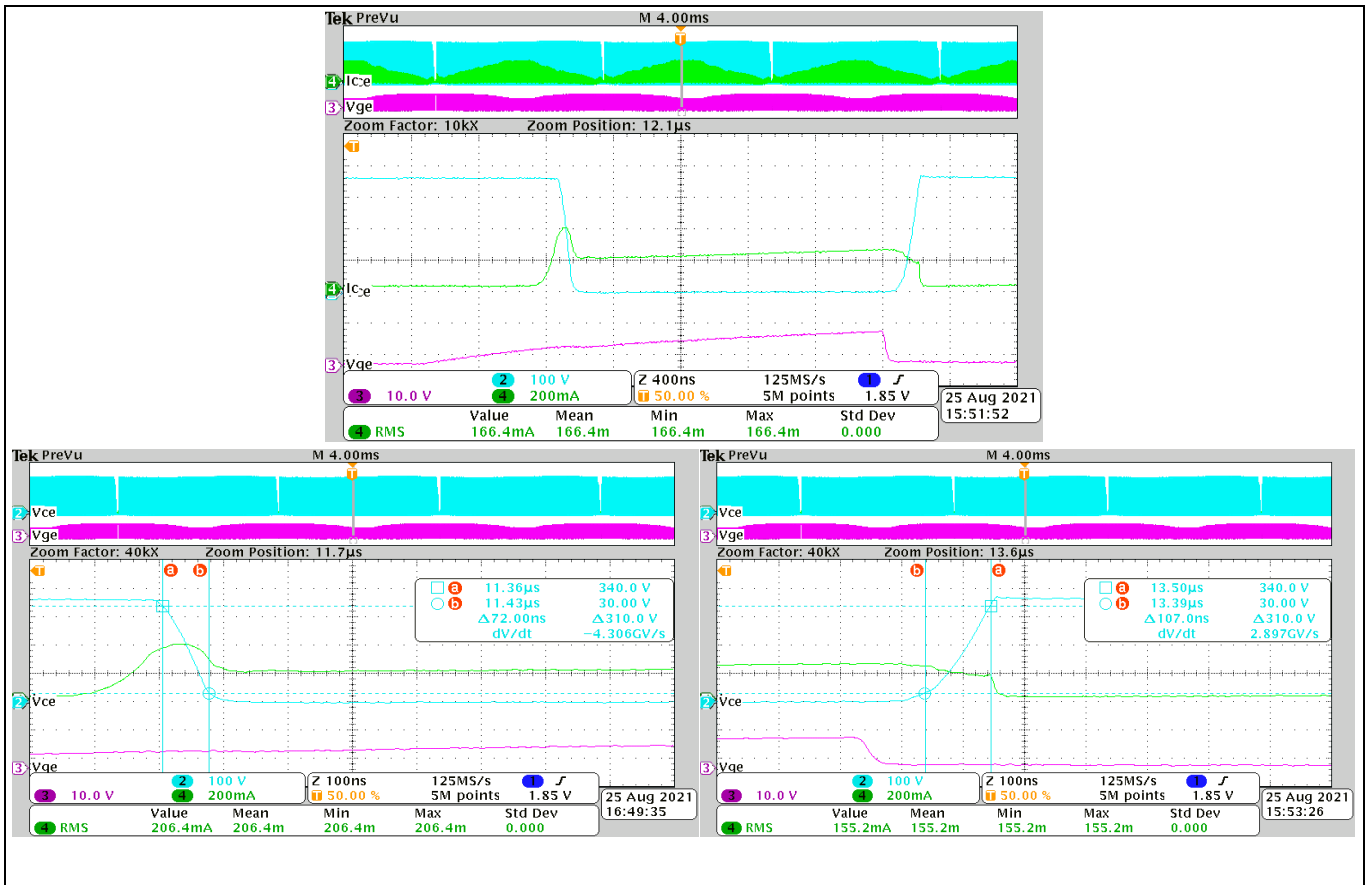

Figure 48 PFC IGBT Vce dv/dt performance at input voltage = 230 V

System performance

4.4 PFC thermal performance

Table 17 PFC thermal performance

Input voltage (V)	Input power (W)	Input current (A)	PFC DC target (V)	Power factor	Component with max temperature	$\Delta T(^{\circ}C)$
120	34.2	0.283	300	1	PFC IGBT	61.2
150	33.9	0.146	300	0.947	PFC IGBT	52.8
230	34.4	0.146	360	0.978	Motor IGBT	61.5

Condition

- PWM setup for: 60 kHz PFC and 16 kHz motor PWM, 3-phase only mode, motor speed: 360 rpm.
- PFC control parameters: Kpl= 400, Kxl=600, KpV= 1500, KxV=30.

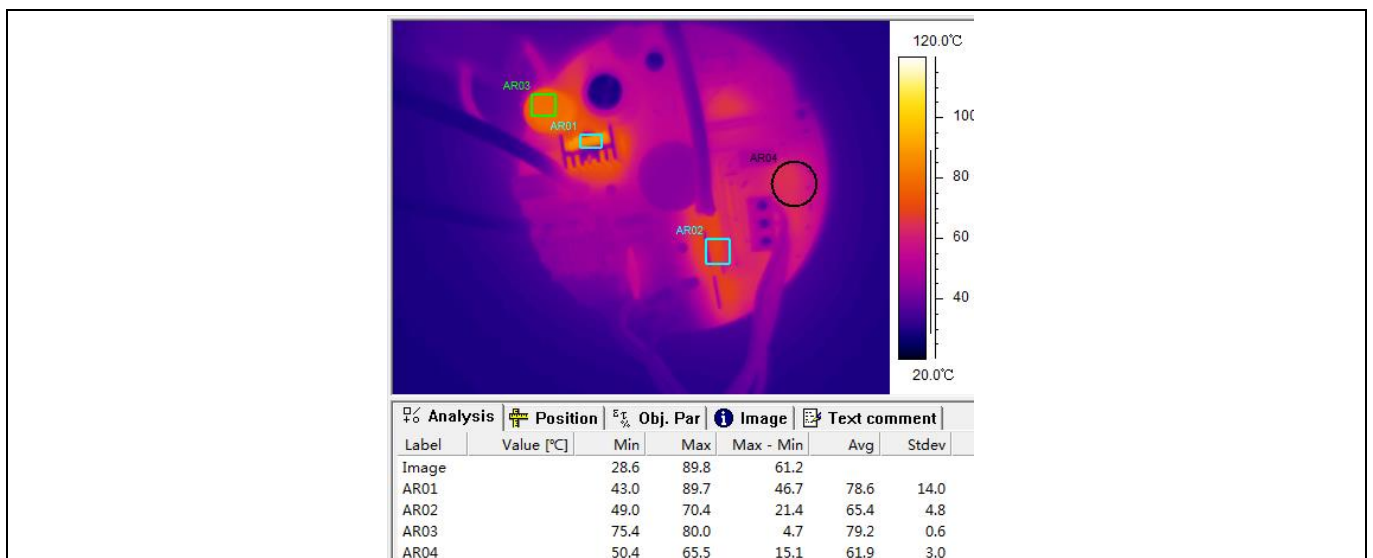

Figure 49 Input voltage = 120 V

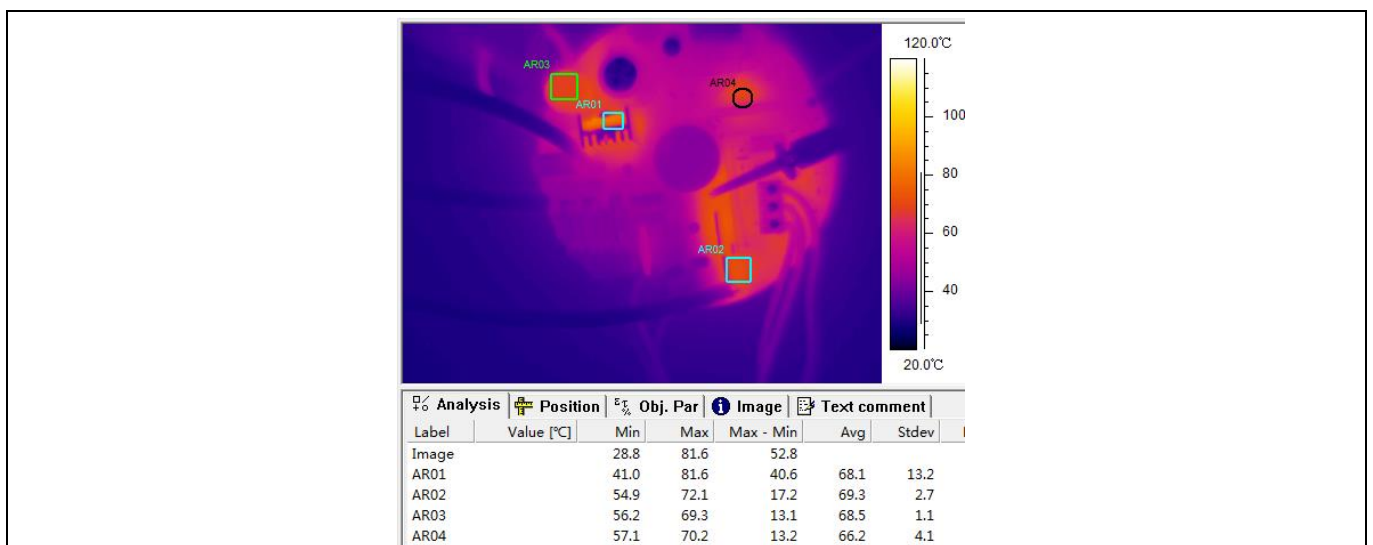

Figure 50 Input voltage = 150 V

System performance

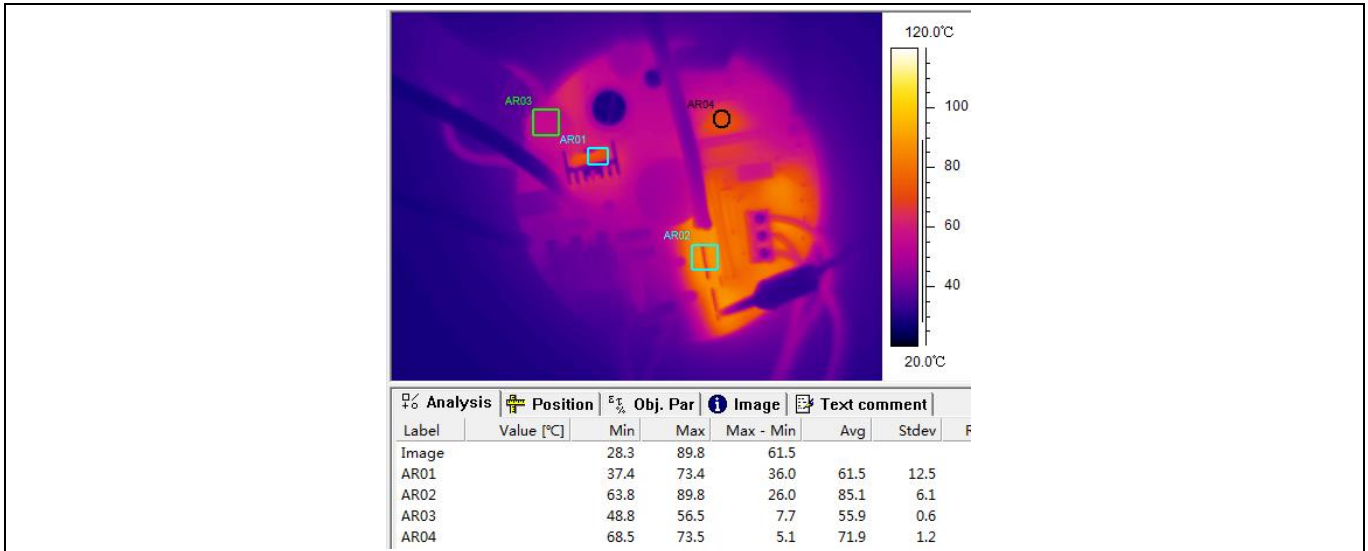

Figure 51 Input voltage = 230 V

4.5 Inverter IGBT dv/dt performance

IKN03N60RC2 is used here for the inverter IGBT dv/dt performance test.

Table 18 Inverter IGBT dv/dt performance

Current position	Input voltage (V)	Input power (W)	PFC DC target (V)	Power factor	dv/dt (V/ns)
At positive current	230	34.5	360	0.976	Rising edge: 0.576 Falling edge: 1.38
Near zero current	230	34.5	360	0.976	Rising edge: 0.514 Falling edge: 1.518
At negative current	230	34.5	360	0.976	Rising edge: 0.36 Falling edge: 1.325

Legend	CH1: Vge for low side, CH4: Vge for high side ,CH3: phase output current, CH2: Vce for low side
Condition	<ul style="list-style-type: none"> PWM setup for: 60 kHz PFC and 16 kHz motor PWM, 3-phase only mode, motor speed: 360 rpm. PFC control parameters: Kpl= 400, Kxl=600, KpV= 1500, KxV=30.

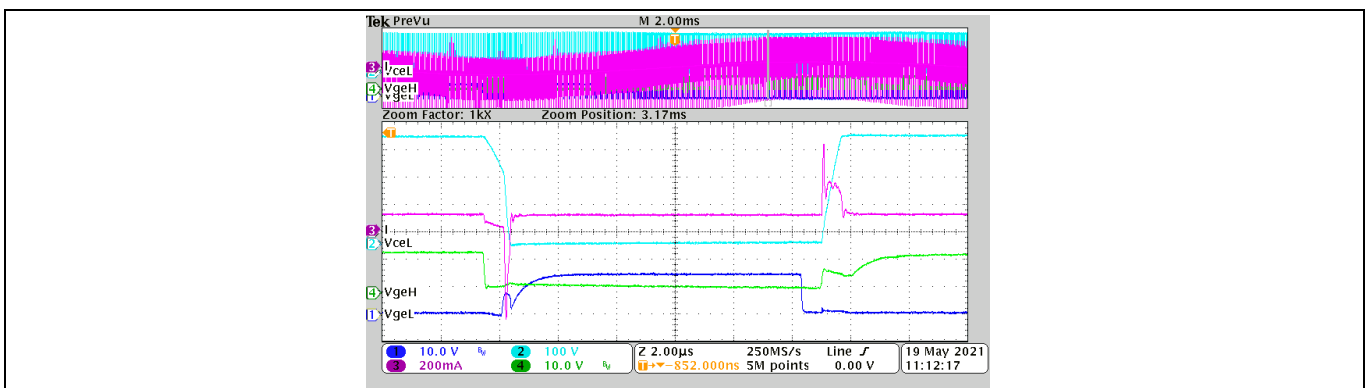

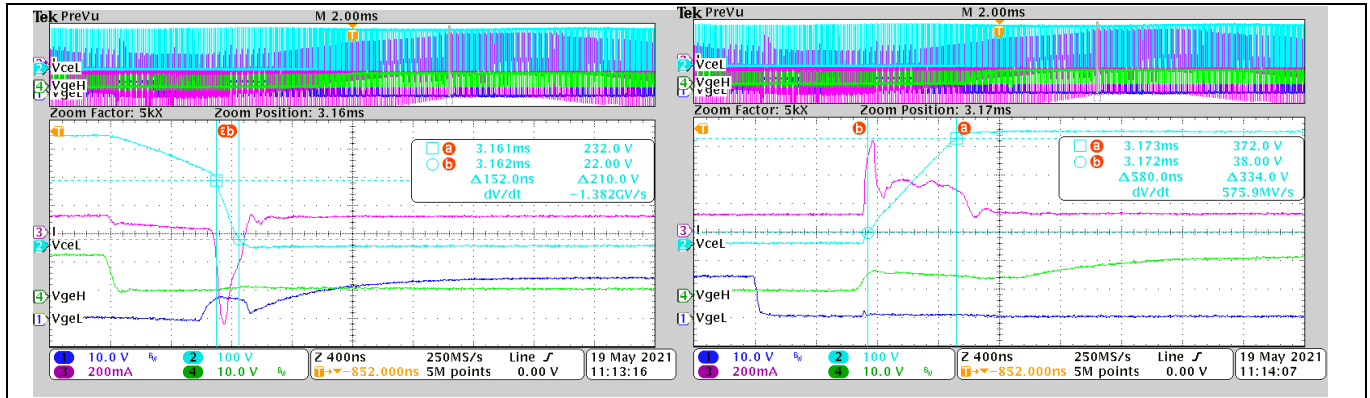

Figure 52 At positive current

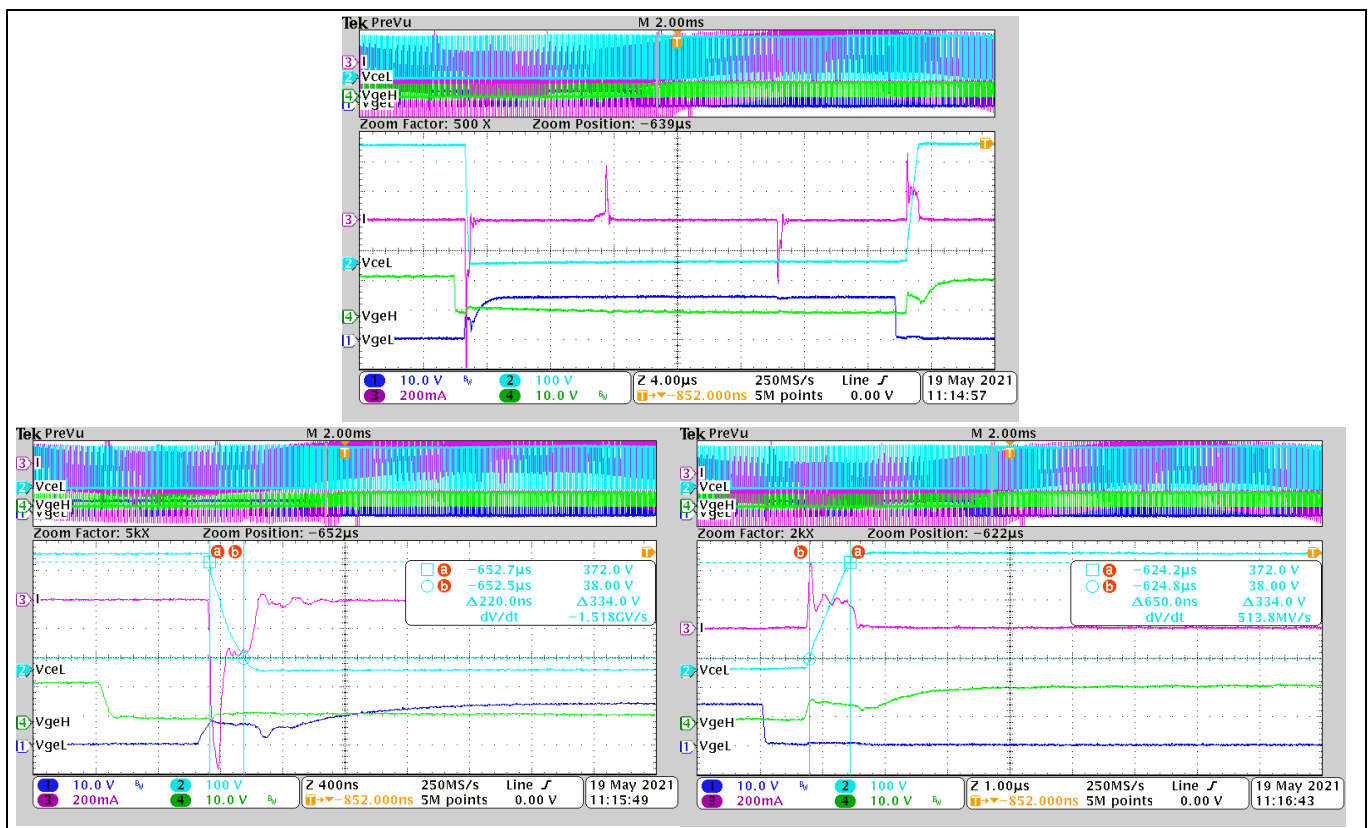
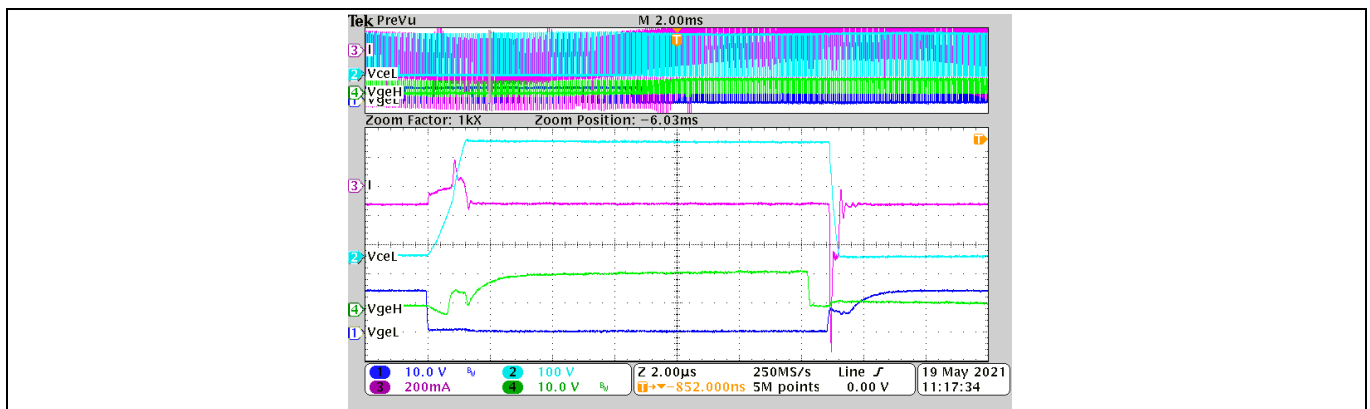

Figure 53 Near zero current



System performance

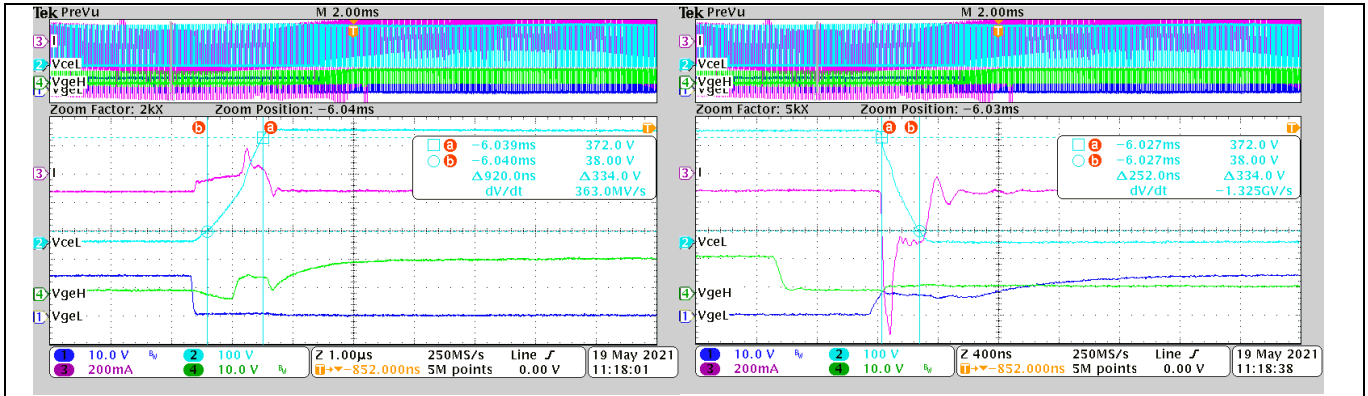

Figure 54 At negative current

4.6 Inverter IGBT dead time test

IKN03N60RC2 is used here for the inverter IGBT dead time test.

Table 19 Inverter IGBT dead time

Input voltage (V)	Input power (W)	PFC DC target (V)	Power factor	Tdon+Tr (ns)	Tdoff+Tf (ns)	Min dead time (ns)
120	35.8	260	1	84	512	428
Legend CH1: Vge for Low side, CH2: Vce for low side, CH3: phase output current.						
Condition						
<ul style="list-style-type: none"> ● PWM setup for: 60 kHz PFC and 16 kHz motor PWM, 3-phase only mode, motor speed: 360 rpm. ● PFC control parameters: Kpl= 400, Kxl=600, KpV= 1500, KxV=30. 						

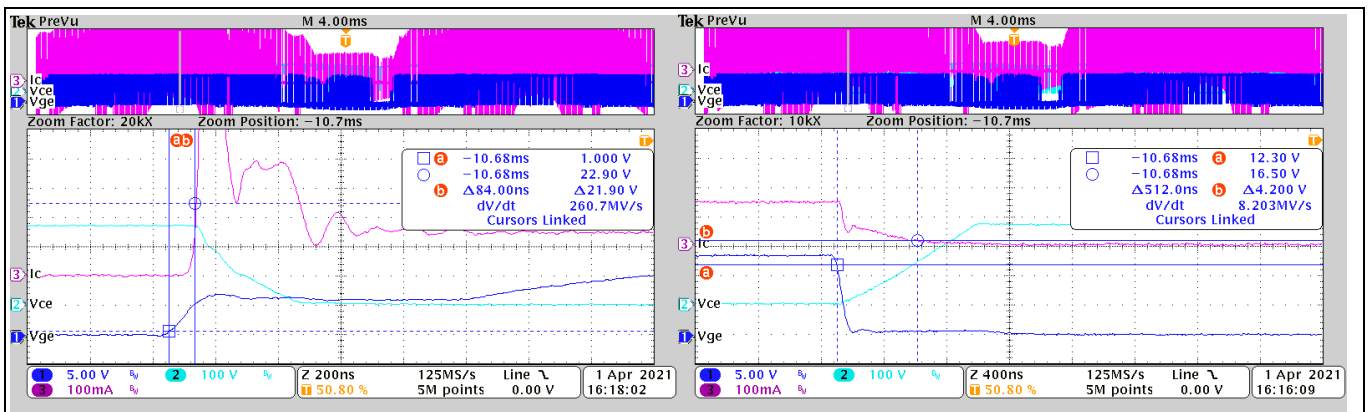

Figure 55 Inverter IGBT dead time

4.7 System test with infrared control

This test connects the main board and daughter board with cables provided, and uses the script code in Section 2.4 for remote infrared control as shown in Figure 6. The test result is shown in Table 20.

System performance

Table 20 System test result

Gear	Input voltage (Vrms)	Motor speed (rpm)	iTHD (%)	Input power (W)	Power factor	Input current (mA)
1	120	39	67.6	1.8	0.814	17
2		119	24.2	3.4	0.956	30
3		199	12.4	8.5	0.971	74
4		279	4.08	20.1	0.996	168
5		360	2.99	37.5	0.999	316
1	150	39	86.1	2.1	0.742	19
2		119	38.1	3.8	0.924	28
3		199	15.2	8.5	0.967	59
4		279	5.84	19.4	0.991	131
5		360	3.79	36.5	0.999	244
1	200	39	92.7	2.9	0.721	21
2		119	67.6	4.6	0.821	29
3		199	22.4	9.7	0.969	51
4		279	8.11	19.7	0.977	101
5		360	4.9	35.7	0.996	180
1	250	39	97.5	3.9	0.705	22
2		119	77.6	5.7	0.776	32
3		199	36.3	10.8	0.937	46
4		279	13.5	20.7	0.981	84
5		360	7.58	34.9	0.986	143
1	265	39	63.7	4.4	0.718	23
2		119	42.3	6.1	0.784	30
3		199	16.5	11.1	0.928	45
4		279	7.63	21.2	0.981	81
5		360	7.58	35.1	0.985	135

5 References and appendices

5.1 Abbreviations and definitions

Table 21 Abbreviations

Abbreviation	Meaning
CE	Conformité Européenne
EMI	Electromagnetic interference
UL	Underwriters Laboratories
RC-D2	Reverse-conducting drive 2

5.2 References

- [1] Infineon Technologies AG. Datasheet of IKN03N60RC2 (2021) V1.0 www.infineon.com
- [2] Infineon Technologies AG. Datasheet of IMD112T-6F040 (2020) V1.0 www.infineon.com
- [3] Infineon Technologies AG. Datasheet of 1ED44171N01B (2021) V1.0 www.infineon.com
- [4] Infineon Technologies AG. MCEWizard_V2.3 User Guide (2019) www.infineon.com
- [5] Infineon Technologies AG. MCEDesigner_V2.3 Application Guide (2019) www.infineon.com
- [6] Infineon Technologies AG. iMOTION™ Motion Control Engine Software Reference Manual (2021) V1.34 www.infineon.com

5.3 Additional information

In order to initiate testing, customers are advised to order the iMOTION™ link; detailed information is listed in Table 22.

The Infineon components on the board are listed in Table 22 as well. The customers can visit the corresponding webpage for more information.

Table 22 Additional information on tools and Infineon components

Base part number	Package	Standard pack		Orderable part number
		Form	Quantity	
iMOTION™ link		Container	1	IMOTIONLINK
IMD112T-6F040	PG-LQFP-40	Tape and reel	1500	IMD112T6F040XUMA1
IKD04N60RC2	PG-TO252-3	Tape and reel	2500	IKD04N60RC2ATMA1
IKN03N60RC2	PG-SOT223-3	Tape and reel	2500	IKN03N60RC2ATMA1
1ED44171N01B	PG-SOT23-5-1	Tape and reel	3000	1ED44171N01BXTSA1
IKA08N65H5	PG-TO220-3	Tube	500	IKA08N65H5XKSA1
XMC1100-Q024F0064 AB	PG-VQFN-24	Tape and reel	6000	XMC1100Q024F0064ABXUMA1

Revision history

Revision history

Document version	Date of release	Description of changes
V 1.0	10/29/2021	Initial version.
V 2.0	1/18/2022	Revised the software preparation and commissioning from Section 2.1.2 to Section 2.1.8.
V3.0	5/11/2022	Changed the PFC gate driver from IRS44273L to 1ED44171N01B. 1) Changed the description of IRS44273L to 1ED44171N01B; 2) Updated the picture in Figure 3; 3) Updated the pictures in Figure37, Figure38, Figure39, Figure40; 4) Updated the component information in Table 25.
V3.1	6/15/2023	1. Schematic and PCB modification: 1) Changed CX1 value from 100nF to 22nF. 2) Changed CX2 value from 330nF to 22nF. 3) Changed C5 and C7 value from 4.7nF to 10nF. 4) Changed C14 to DNI(unmounted). 2. Deleted EMI test 3. Deleted Surge test 4. Changed input voltage range to 120~265V _{rms}

Trademarks

All referenced product or service names and trademarks are the property of their respective owners.

Edition 2023-6-15

Published by

Infineon Technologies AG

81726 Munich, Germany

© 2023 Infineon Technologies AG.

All Rights Reserved.

Do you have a question about this document?

Email: erratum@infineon.com

Document reference

UG-2021-37

For further information on the product, technology, delivery terms and conditions and prices please contact your nearest Infineon Technologies office (www.infineon.com).

WARNINGS

Due to technical requirements products may contain dangerous substances. For information on the types in question please contact your nearest Infineon Technologies office.

Except as otherwise explicitly approved by Infineon Technologies in a written document signed by authorized representatives of Infineon Technologies, Infineon Technologies' products may not be used in any applications where a failure of the product or any consequences of the use thereof can reasonably be expected to result in personal injury.