

# REF-MHA0K2IMC101T user guide

## Refrigerator compressor driver reference design kit

### About this document

#### Scope and purpose

This user guide provides an overview of the reference design board REF-MHA0K2IMC101T including its main features, key data, pin assignments and mechanical dimensions, and the guidance on how to run and design the motor with board.

The REF-MHA0K2IMC101T board is a complete reference design board designed for refrigerator compressors. It demonstrates the entire Infineon solution including CIPOS™ Micro series IPM IM241-L6S1B, digital motor control IC iMOTION™ IMC101T-T038 and linear voltage regulators TLS202B1MBV33.

The REF-MHA0K2IMC101T board is developed to support customers in designing their refrigerator compressor drivers with Infineon products.

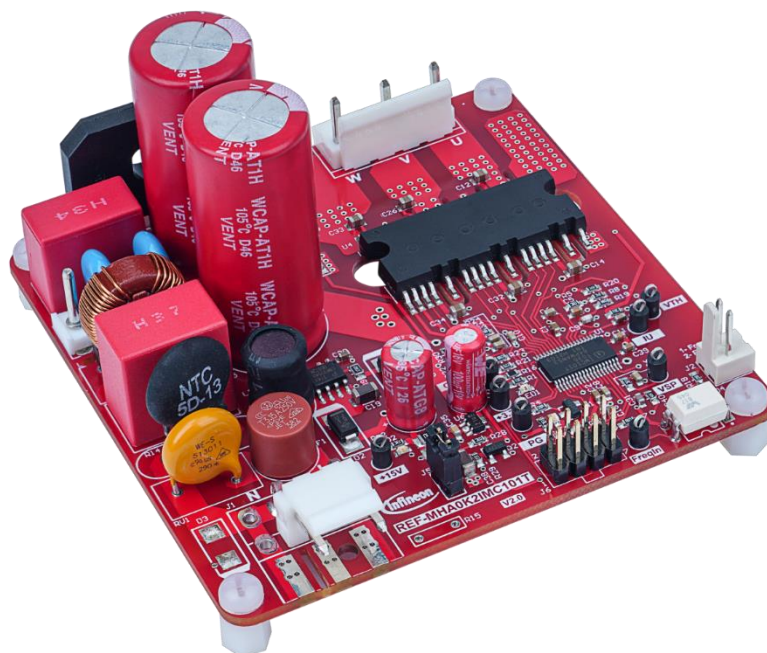
#### Intended audience

This user guide is intended for technical specialists working with the REF-MHA0K2IMC101T board and refrigerator compressor driver design.

#### Reference board/kit

Product(s) embedded on a PCB, with focus on specific applications and defined use cases that can include Software. PCB and auxiliary circuits are optimized for the requirements of the target application.

*Note: Boards do not necessarily meet safety, EMI, quality standards (for example UL, CE) requirements.*



**Important notice**

**Important notice**

**“Evaluation Boards and Reference Boards” shall mean products embedded on a printed circuit board (PCB) for demonstration and/or evaluation purposes, which include, without limitation, demonstration, reference and evaluation boards, kits and design (collectively referred to as “Reference Board”).**

**Environmental conditions have been considered in the design of the Evaluation Boards and Reference Boards provided by Infineon Technologies. The design of the Evaluation Boards and Reference Boards has been tested by Infineon Technologies only as described in this document. The design is not qualified in terms of safety requirements, manufacturing and operation over the entire operating temperature range or lifetime.**

**The Evaluation Boards and Reference Boards provided by Infineon Technologies are subject to functional testing only under typical load conditions. Evaluation Boards and Reference Boards are not subject to the same procedures as regular products regarding returned material analysis (RMA), process change notification (PCN) and product discontinuation (PD).**

**Evaluation Boards and Reference Boards are not commercialized products, and are solely intended for evaluation and testing purposes. In particular, they shall not be used for reliability testing or production. The Evaluation Boards and Reference Boards may therefore not comply with CE or similar standards (including but not limited to the EMC Directive 2004/EC/108 and the EMC Act) and may not fulfill other requirements of the country in which they are operated by the customer. The customer shall ensure that all Evaluation Boards and Reference Boards will be handled in a way which is compliant with the relevant requirements and standards of the country in which they are operated.**

**The Evaluation Boards and Reference Boards as well as the information provided in this document are addressed only to qualified and skilled technical staff, for laboratory usage, and shall be used and managed according to the terms and conditions set forth in this document and in other related documentation supplied with the respective Evaluation Board or Reference Board.**

**It is the responsibility of the customer’s technical departments to evaluate the suitability of the Evaluation Boards and Reference Boards for the intended application, and to evaluate the completeness and correctness of the information provided in this document with respect to such application.**

**The customer is obliged to ensure that the use of the Evaluation Boards and Reference Boards does not cause any harm to persons or third party property.**

**The Evaluation Boards and Reference Boards and any information in this document is provided "as is" and Infineon Technologies disclaims any warranties, express or implied, including but not limited to warranties of non-infringement of third party rights and implied warranties of fitness for any purpose, or for merchantability.**

**Infineon Technologies shall not be responsible for any damages resulting from the use of the Evaluation Boards and Reference Boards and/or from any information provided in this document. The customer is obliged to defend, indemnify and hold Infineon Technologies harmless from and against any claims or damages arising out of or resulting from any use thereof.**

**Infineon Technologies reserves the right to modify this document and/or any information provided herein at any time without further notice.**

Safety precautions

Safety precautions

Note: Please note the following warnings regarding the hazards associated with development systems.

Table 1 Safety precautions

	<p><b>Warning:</b> The DC link potential of this board is up to 400 VDC. When measuring voltage waveforms by oscilloscope, high voltage differential probes must be used. Failure to do so may result in personal injury or death.</p>
	<p><b>Warning:</b> The evaluation or reference board contains DC bus capacitors which take time to discharge after removal of the main supply. Before working on the drive system, wait five minutes for capacitors to discharge to safe voltage levels. Failure to do so may result in personal injury or death. Darkened display LEDs are not an indication that capacitors have discharged to safe voltage levels.</p>
	<p><b>Warning:</b> The evaluation or reference board is connected to the grid input during testing. Hence, high-voltage differential probes must be used when measuring voltage waveforms by oscilloscope. Failure to do so may result in personal injury or death. Darkened display LEDs are not an indication that capacitors have discharged to safe voltage levels.</p>
	<p><b>Warning:</b> Remove or disconnect power from the drive before you disconnect or reconnect wires, or perform maintenance work. Wait five minutes after removing power to discharge the bus capacitors. Do not attempt to service the drive until the bus capacitors have discharged to zero. Failure to do so may result in personal injury or death.</p>
	<p><b>Caution:</b> The heat sink and device surfaces of the evaluation or reference board may become hot during testing. Hence, necessary precautions are required while handling the board. Failure to comply may cause injury.</p>
	<p><b>Caution:</b> Only personnel familiar with the drive, power electronics and associated machinery should plan, install, commission and subsequently service the system. Failure to comply may result in personal injury and/or equipment damage.</p>
	<p><b>Caution:</b> The evaluation or reference board contains parts and assemblies sensitive to electrostatic discharge (ESD). Electrostatic control precautions are required when installing, testing, servicing or repairing the assembly. Component damage may result if ESD control procedures are not followed. If you are not familiar with electrostatic control procedures, refer to the applicable ESD protection handbooks and guidelines.</p>
	<p><b>Caution:</b> A drive that is incorrectly applied or installed can lead to component damage or reduction in product lifetime. Wiring or application errors such as undersizing the motor, supplying an incorrect or inadequate AC supply, or excessive ambient temperatures may result in system malfunction.</p>
	<p><b>Caution:</b> The evaluation or reference board is shipped with packing materials that need to be removed prior to installation. Failure to remove all packing materials that are unnecessary for system installation may result in overheating or abnormal operating conditions.</p>

**Table of contents**

**Table of contents**

**About this document..... 1**

**Important notice ..... 2**

**Safety precautions..... 3**

**Table of contents..... 4**

**1 The board at a glance..... 5**

1.1 Delivery content .....5

1.2 Block diagram.....5

1.3 Main features .....6

1.4 Board parameters and technical data.....7

**2 System and functional description ..... 9**

2.1 Commissioning.....9

2.1.1 Hardware connection .....10

2.1.2 Software/firmware preparation .....11

2.1.3 Program firmware/parameters/script.....11

2.1.4 Open-loop diagnostic .....13

2.1.5 Closed-loop run.....14

2.2 Description of the functional blocks.....15

2.2.1 IPM .....15

2.2.2 DC bus sensing and MCEWizard configuration .....16

2.2.3 Current sensing and overcurrent protection .....17

2.2.3.1 Current sensing .....17

2.2.3.2 Overcurrent protection.....19

2.2.4 NTC sensing and thermal protection .....22

2.3 Frequency signal interface.....23

2.4 Linear voltage regulator and control.....24

**3 Details of the schematics, layout, BOM and connectors .....25**

3.1 Schematics .....25

3.2 Layout .....25

3.3 Bill of material .....26

3.4 Connector details .....27

**4 System performance .....29**

4.1 Thermal characterization test .....29

**5 Reference and appendices .....31**

5.1 Abbreviations and definitions.....31

5.2 Reference.....31

5.3 Additional information.....31

**Revision history.....32**

# REF-MHA0K2IMC101T user guide

## Refrigerator compressor driver reference design kit

### The board at a glance

## 1 The board at a glance

The REF-MHA0K2IMC101T reference design kit is a part of the iMOTION™ reference design kit for motor drives, which is aimed at driver applications for refrigerator compressors. The kit is a ready-to-use solution in combination with Infineon products such as CIPOS™ Micro IPM IM241-L6S1B, digital motor control IC iMOTION™ IMC101T-T038 and linear voltage regulator TLS202B1MBV33. It can easily be switched to a final mass-production application board, and has a fast time to market.

The REF-MHA0K2IMC101T reference board is available from Infineon. The features of this board are described in Chapter 1.3 of this document (UG-2022-13). The remaining sections provide information to enable customers to copy, modify and qualify the design for production according to their own specific requirements.

Environmental conditions have been considered in the design of the REF-MHA0K2IMC101T. The design was tested as described in this document but not qualified in terms of safety requirements or manufacturing and operation over the entire operating temperature range or lifetime. The boards provided by Infineon are subject to functional testing only.

The boards are not subject to the same procedures as regular products in terms of returned material analysis (RMA), process change notification (PCN) and product discontinuation (PD). Reference boards are intended for use under laboratory conditions by specialists only.

### 1.1 Delivery content

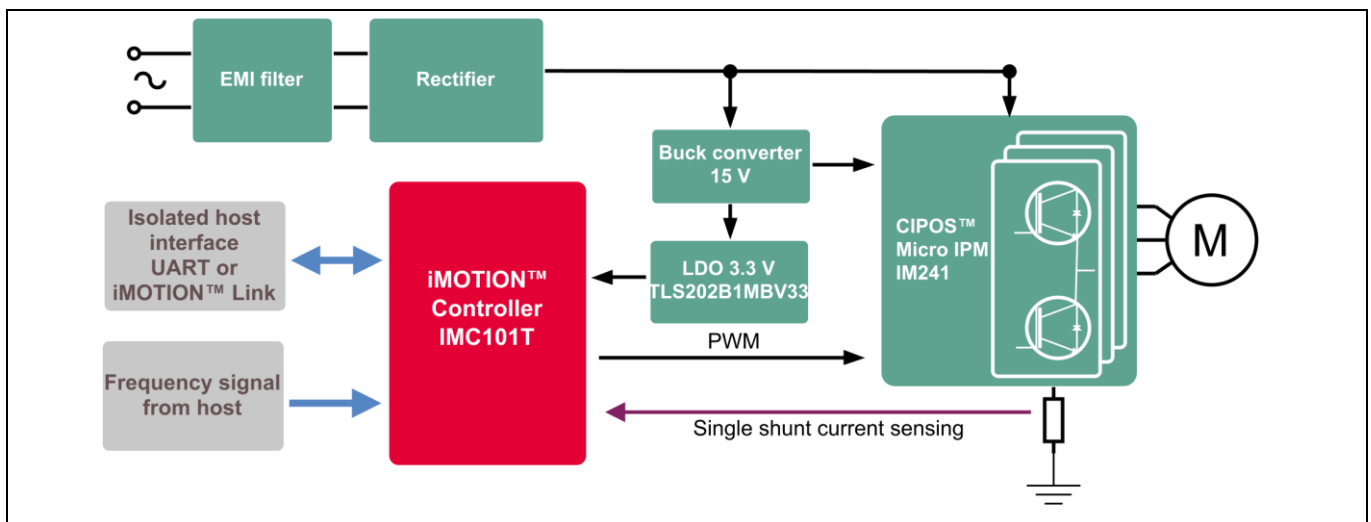
The delivery content only contains the board as Figure 2 shown, the detail ordering information is indicated in the Table 2.

The iMOTION™ Link cable shown in the Figure 4 is mandatory for the tuning, and it is not included in the delivery content, please order it if you do not have, ordering information can be found in the section 5.3.

**Table 2 Delivery content**

Base part number	Package	Standard pack		Orderable part number
		Form	Quantity	
<a href="#">REF-MHA0K2IMC101T</a>		Boxed	1	REFMHA0K2IMC101TTOBO1

### 1.2 Block diagram

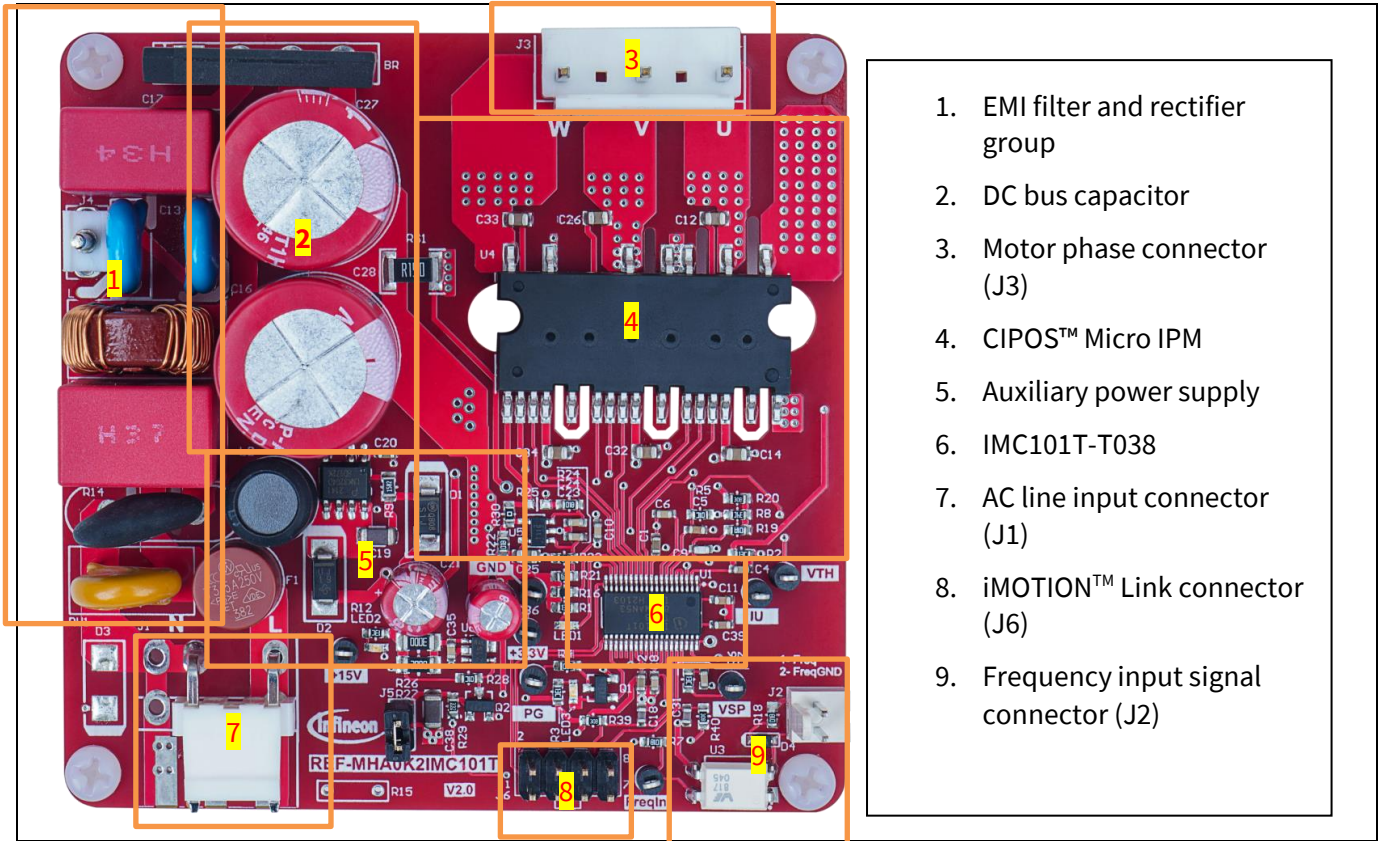


**Figure 1 The block diagram of the REF-MHA0K2IMC101T reference board**

**The board at a glance**

Figure 1 shows the reference design kit REF-MHA0K2IMC101T. This document explains the features and details.

Figure 2 depicts the functional groups of the board. Connector definition details are described in section 0; please see this section if you need more information.



1. EMI filter and rectifier group
2. DC bus capacitor
3. Motor phase connector (J3)
4. CIPOST™ Micro IPM
5. Auxiliary power supply
6. IMC101T-T038
7. AC line input connector (J1)
8. iMOTION™ Link connector (J6)
9. Frequency input signal connector (J2)

**Figure 2 Functional groups on top side of board**

**1.3 Main features**

REF-MHA0K2IMC101T is a complete reference design board including a 3-phase IPM for motor drive applications. The kit demonstrates Infineon’s IPM technology for motor drives.

Main features of IPM IM241-L6S1B include <sup>[1]</sup>:

- Reverse Conducting IGBT Gen 2 (RCD2) optimized for motor drives
- Fast and slow speeds versions for low loss and low EMI operation
- Temperature monitor with NTC
- Accurate overcurrent shutdown ( $\pm 5\%$ )
- Fault reporting and programmable fault clear
- Advanced input filter with shoot-through protection
- Open-emitter for single and leg-shunt current sensing
- Isolation 2000 V<sub>RMS</sub>, 1min
- HV H3TRB qualified
- UL-certified

**The board at a glance**

Main features of iMOTION™ controller IMC101T include [2]:

- Motion control engine as ready-to-use controller solution for sensorless and Hall-sensor motor drives
- Field-oriented control (FOC) for permanent magnet synchronous motor (PMSM/BLDC)
- Optional support for Hall sensors (analog or digital)
- Space vector PWM with sinusoidal commutation and integrated protection features
- Current sensing via single shunt or leg shunt
- Integrated analog comparators for overcurrent protection
- Integrated scripting engine for application flexibility
- 3.3 V or 5.0 V supply voltage options for controller
- Flexible host interface options for speed commands: UART, SPI, PWM or analog signal
- Class B pre-certification (IEC60335) for MCE2.0 firmware

For more information about the above-mentioned products, refer to the corresponding reference material.

**1.4 Board parameters and technical data**

Table 3 depicts the important specifications of the reference design REF-MHA0K2IMC101T.

**Table 3 REF-MHA0K2IMC101T board specifications**

Parameter	Symbol	Conditions / comments	Value	Unit
Operation input voltage	$V_{ac}$	Lower AC input, less motor power output	165 ~ 265	$V_{rms}$
Maximum input current	$I_{ac(max)}$	Input 220 $V_{AC}$ , $T_a=25^{\circ}C$	1.5	$A_{rms}$
Maximum input power	$P_{in(max)}$	Input 220 $V_{AC}$ , $f_{PWM}=5$ kHz, $T_a=25^{\circ}C$ , $T_{case}=100^{\circ}C$ without heat sink	200	W
Maximum motor current	$I_{mtr(max)}$	Input 220 $V_{AC}$ , $f_{PWM}=5$ kHz, $T_a=25^{\circ}C$ , $T_{case}=100^{\circ}C$ without heat sink	0.6	$A_{rms}$
Maximum DC bus voltage	$V_{dc(max)}$		400	V
Shunt Resistance	$R_{sh}$		150	m $\Omega$
<b>Protection</b>				
Current protection trigger level	$I_{trip}$	Level by external comparator circuit	$3.05^1$	$A_{peak}$
Thermal protection level	$T_{protection}$	Temperature gap between junction and NTC (negative temperature coefficient) sensor needs to be considered; recommended is a setting of 105°C or less	105	°C
<b>Auxiliary power supply 1 - 15V</b>				
Output voltage	$V_{out1}$		$15 \pm 5\%$	V
Maximum output current	$I_{out1}$		100	mA
<b>Auxiliary power supply 2 - 3.3V</b>				
Output voltage	$V_{out2}$		$3.3 \pm 5\%$	V
Maximum output current	$I_{out2}$		150	mA
<b>PCB characteristics</b>				
Dimension		Length × width × height	78×78×46	mm
Material		1.6 mm thickness, 1 oz. copper	FR4	

**The board at a glance**

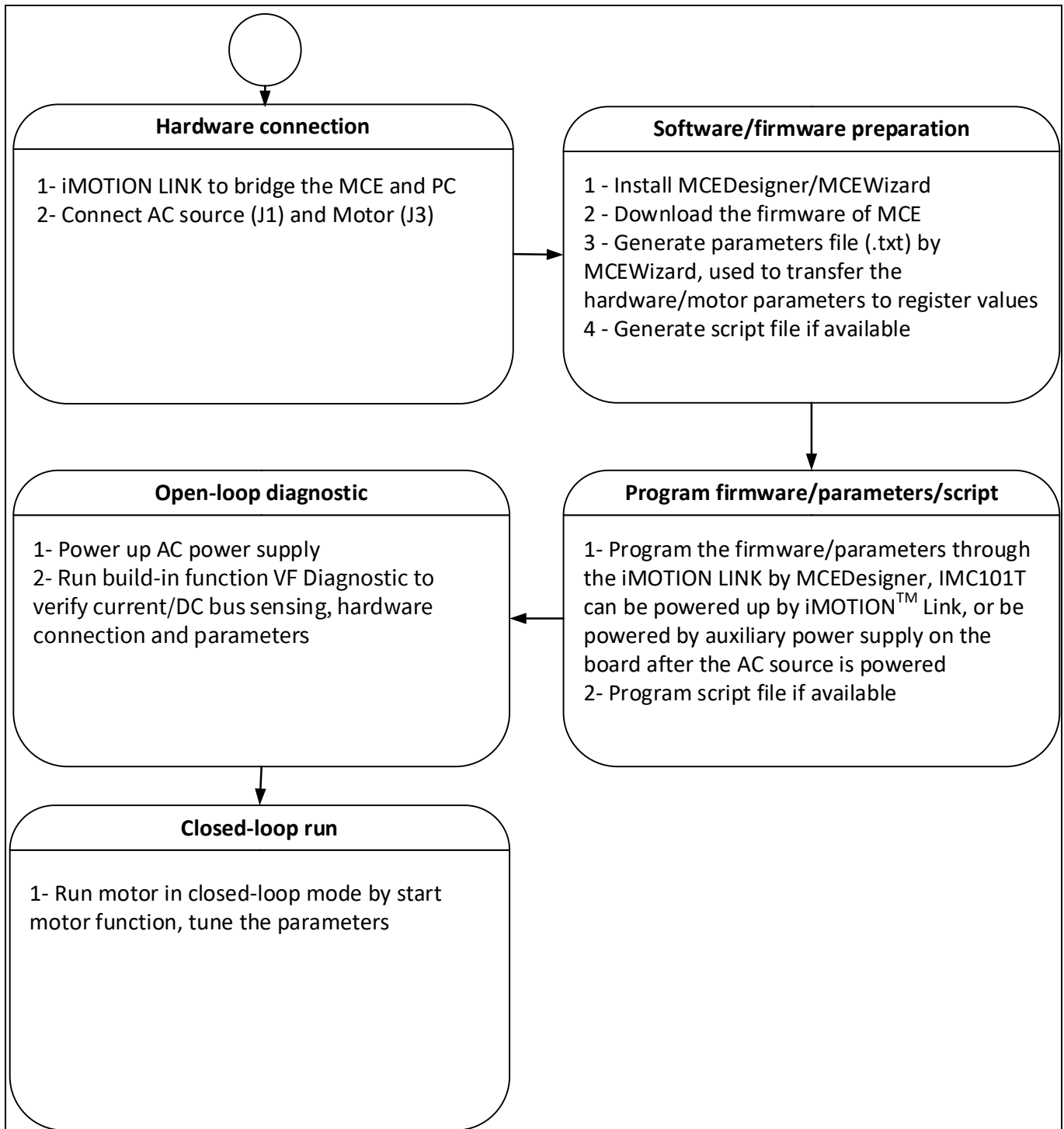
Parameter	Symbol	Conditions / comments	Value	Unit
<b>System environment</b>				
Ambient temperature	$T_a$	Non-condensing, maximum RH of 95%	0 ~ 50	°C

*Note:* 1. For iMOTION™ IC IMC1xx, there are three types of Gatekill input source options in MCEWizard setup. If “comparator” mode is selected, the external Gatekill signal will be not used, and the signal  $V_{Shunt}$  will be compared by the internal comparator with the “Device overcurrent trigger level setting” value set in MCEWizard.



## 2 System and functional description

### 2.1 Commissioning



**Figure 3 Basic process for running the motor the first time**

This section describes how to get the system working when user first installs the board (refer to Figure 3 for general steps). The following items detail these steps. For those who are already familiar with the system, or have already run the board, unnecessary steps can be skipped depending on user's actual situation. For more in-depth commissioning requirements, please refer to the MCE reference manual or the corresponding reference material <sup>[5][6][7]</sup>.

# REF-MHA0K2IMC101T user guide

## Refrigerator compressor driver reference design kit

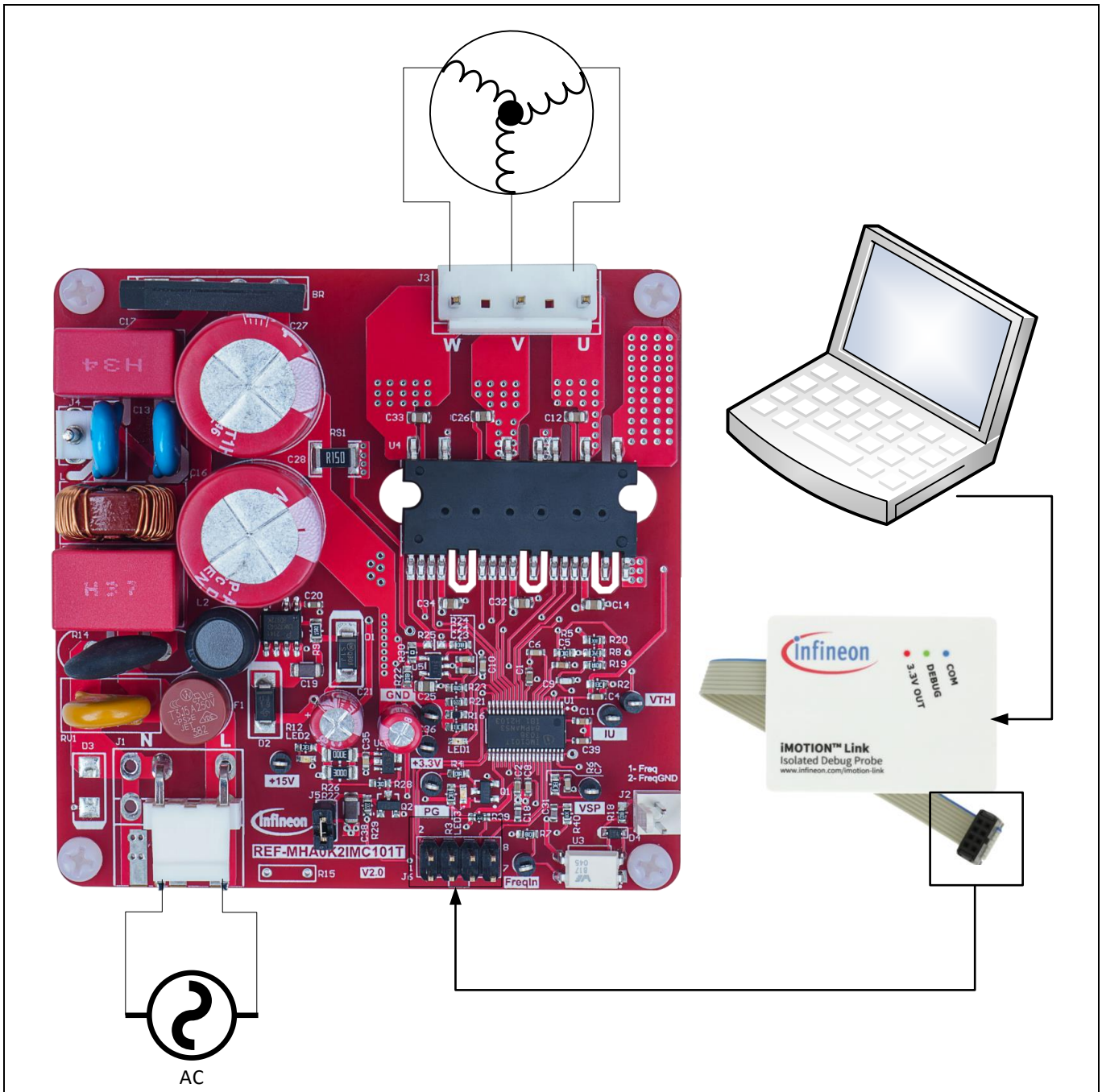
### System and functional description

#### 2.1.1 Hardware connection

Figure 4 shows the hardware connection details for the reference design board.

The [iMOTION™ Link](#) cable is needed to bridge the PC/debugger side and motor drive system (the target iMOTION™ device, hot side) with 1 kV DC galvanic isolation. Users can go to section 5.3 for more information about iMOTION™ Link.

1. Connect iMOTION™ Link's 8-pin cable to J6 with default pin order, and connect PC and iMOTION™ Link with the USB wire.
2. Then connect AC power supply (J1) and the motor (J3).



**Figure 4** Hardware connection details

**System and functional description**

**2.1.2 Software/firmware preparation**

1. The iMOTION™ software tools MCEDesigner and MCEWizard are required in order to initially set up the system, as well as to control and fine-tune the system performance to match the user's exact needs. These tools are available for download via the Infineon website (<http://www.infineon.com/imotion-software>). Please check this page periodically for tool/software updates.
2. The MCE firmware then has to be downloaded on our website; select the proper version of the firmware based on your requirements. Included in the package are the firmware ('.ldf'), default parameters ('.txt'), the default map file ('.map'), the file for the MCEDesigner ('.irc') and other documents.
3. Generate your parameters' file.
  - Use MCEWizard to enter the target motor's system and operating parameters, as well as reference board's hardware parameters, which will then be used to calculate the controller's digital parameter set representing the complete motor drive system.
  - After system and operating parameters are set, go to the "Verify & Save Page" and click on "Calculate" button. If no errors are reported, then save the drive parameter set in your project directory by clicking "Export to Designer file (.txt)" (Figure 7); if some errors are detected, double-click on the error message (highlighted in red) and adjust the related parameters. Saved drive system parameter file will be later used for programmers.

*Note: After you log-in on myInfineon, you could download the default MCEwizard file (.mc2) for this board, you only need to modify the parameters related to your motor to make things easier and save time.*

4. Generate the script if available. For users who are tuning the board for the first time, it is recommended not to use this function first, but to add the script function after the motor commissioning is completed.

**2.1.3 Program firmware/parameters/script**

The REF-MHA0K2IMC101T reference design kit is shipped with pre-programmed firmware and default parameters, since the functional tests were done before shipment. Users need to program their parameters, as the motor is different from the one under test.

The following steps have to be performed in order to achieve a usable motor controller IC from a blank IMC101T:

- Program the firmware of the motion control engine (MCE)
- Program parameter sets for system and motor
- Program customer script file (optional)

Or

- Program the combined file, which is combined by MCEWizard containing all three items above. Customer script file is optional depending on whether it is available. The combined file is usually used for production, since it only needs to be programmed once.

The programming process is as follows:

1. Start the MCEDesigner tool and open MCEDesigner default configuration file (.irc) for IMC101T device (IMC101T\_Vxxx.irc) by clicking "File" > "Open".

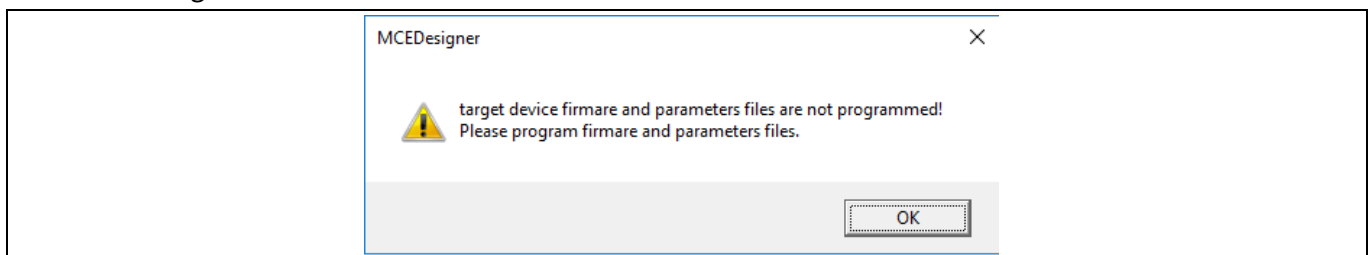
*Note: The IMC101T\_Vxxx.irc file is included in the downloaded firmware package "IMC101T MCE Software Package."*

# REF-MHA0K2IMC101T user guide

## Refrigerator compressor driver reference design kit

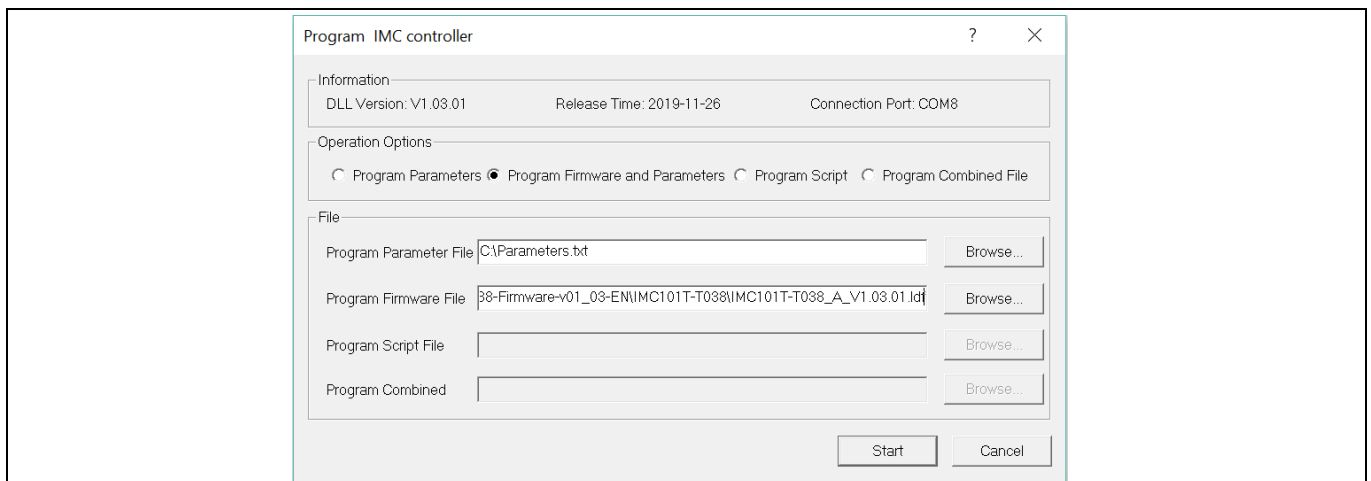
### System and functional description

2. Power the iMOTION™ control IC with 3.3 V. It is recommended to program the IC with the 3.3 V isolated power supply that comes from the iMOTION™ Link. There is a switch on the iMOTION™ Link to enable the 3.3 V output. The iMOTION™ control IC will also be powered by the onboard auxiliary power supply after the AC source is powered, but caution due to high voltage.
3. MCEDesigner should automatically connect to the board using default COM port (indicated by green circle next to “COMx Up” status in the bottom frame of the MCEDesigner GUI) when iMOTION™ control IC is powered. If it cannot establish the connection due to an incorrect COM port, change COM port by doing the following: click on the “System Page” window and then click on “Preferences > Connection > Connect using,” and choose one of the other available COM ports from the drop-down list.
4. (In the case of a blank IC) If the firmware has been erased from the IMC101T, the following warning message will pop up “Target device firmware and parameters file are not programmed! Please program firmware and parameters file” as Figure 5. Then you can program as described in the step 5. If it is not the blank IC, no such message will be indicated.

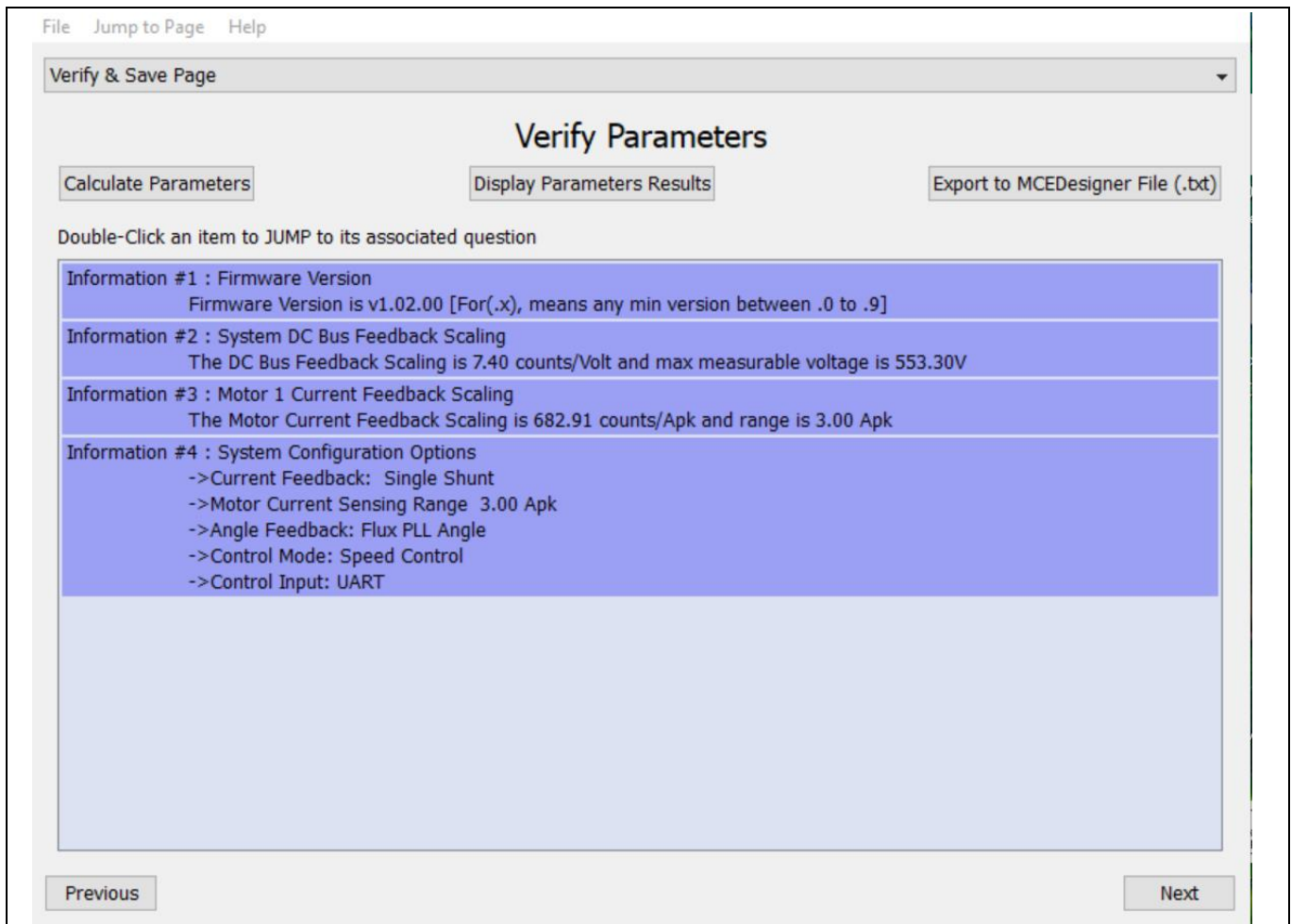


**Figure 5** MCEDesigner warning message

5. Use the following steps to program the firmware and the parameters' file into the internal flash memory of iMOTION™ Control IC: click on system page, click “Tools” > “Programmer” and select “Program Firmware and Parameters.” Shown as in Figure 6 below. The encrypted firmware is available at “IMC101T MCE Software Package;” regarding the parameters' file, browse and select the'.txt' file in Section 2.1.2.



**Figure 6** Program the parameters and firmware



**Figure 7** MCEWizard verify and save page

### 2.1.4 Open-loop diagnostic

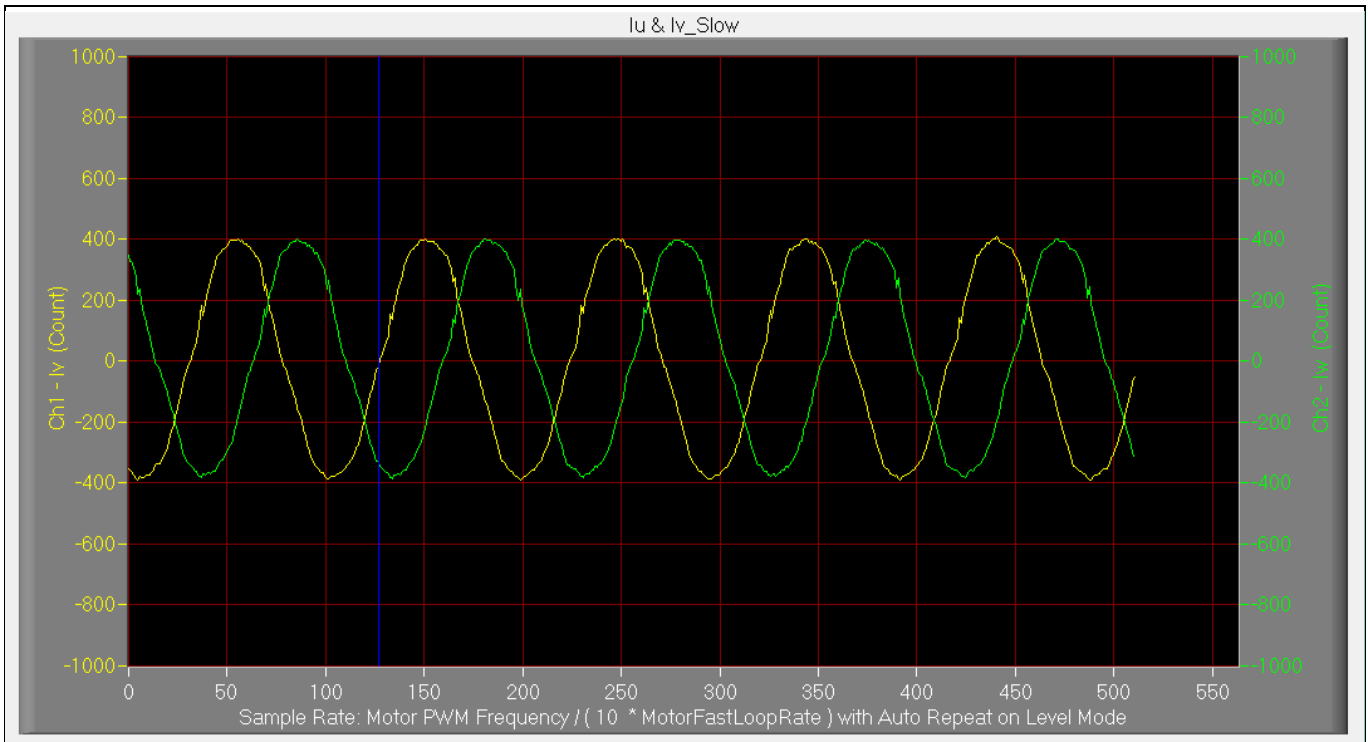
Double click the “VF Diagnostic” function in motor1 page, and monitor the motor current with oscilloscope. If the motor current is not sinusoidal, change the TargetSpeed and Vd\_Ext in VF Diagnostic sub-function, then double click “VF Diagnostic,” until the oscilloscope shows a steady sinusoidal current, with an amplitude of 30~50% motor rate current.

Double click “Iu & Iv\_Slow” in System page - Monitor Definitions. The motor current feedback should be very clean and sinusoidal, as shown in Figure 8; otherwise please tune “Gating Propagation Delay & Phase Shift Window Size” in MCE Wizard.

“VF Diagnostic” sub-function can verify:

- If motor is connected correctly
- If the IPM works as expected
- If current-sensing related parameters are correctly configured
- If PCB layout and DC bus decoupling has been done correctly

After the “VF Diagnostic” is done, click STOP button (the red traffic light button) or run “Stop Motor” function to stop the motor.



**Figure 8** Trace waveform for Iu & Iv open loop diagnostic

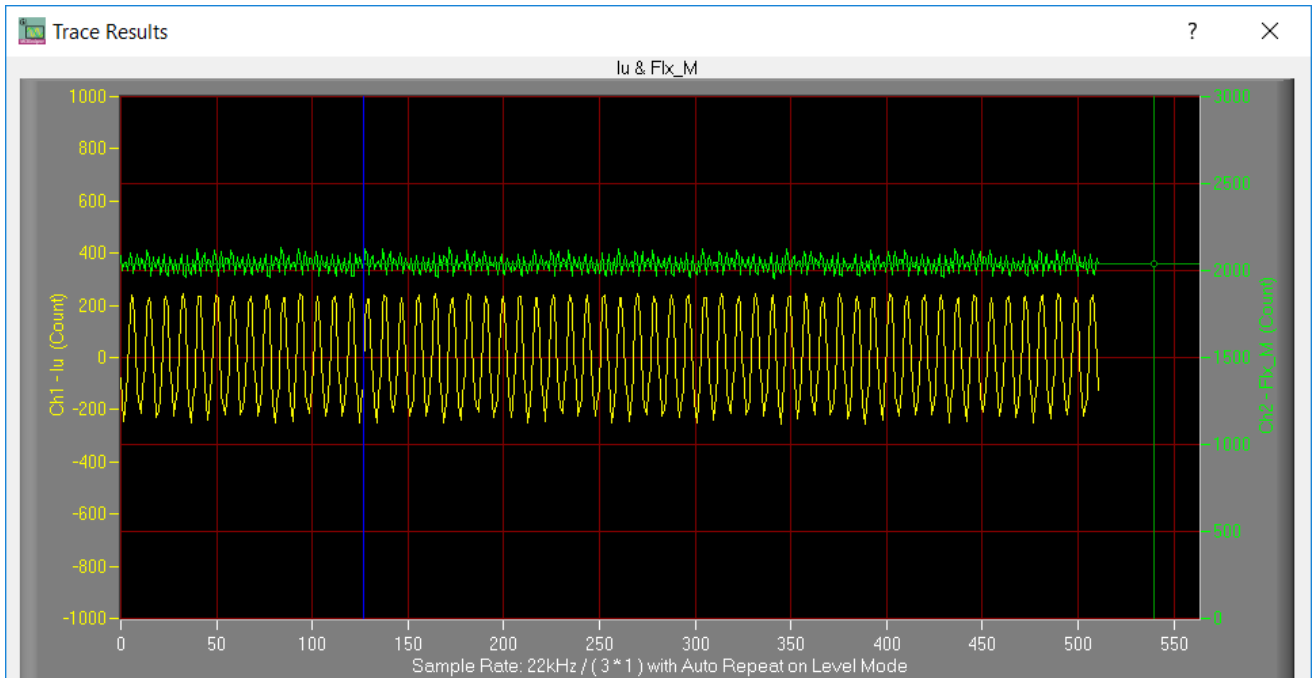
### 2.1.5 Closed-loop run

If the VF Diagnostic works correctly, the hardware circuit and signal sampling will work normally, at which point we can try to run the motor in a closed-loop mode. The steps are listed below.

1. Start the motor by clicking the green traffic light button in the control bar (or double-click “Start Motor” function on Motor1 page, which is in the group of user application function definitions). The motor will run if the above step works well.
2. Check the motor spin direction, adjust the motor winding’s connection order, or set negative TargetSpeed in MCE Designer if the direction is wrong.
3. Set TargetSpeed to about 50% of maximum speed, start “Iu & Flx\_M” trace with “Auto Repeat On Level,” see Figure 9. Flx\_M is good within the range of 2000~2500 (rated value is 2048), and must be steady and DC-like.

Here are some key tips for better motor-performance tuning:

- If Flx\_M is not steady (swing or oscillation), the motor parameters, speed loop PI gain, flux Estimator time constant and PLL PI bandwidth (parameters PLLKp & PLLKi) and related setup need to be checked.
- If Flx\_M is very noisy, the current feedback and  $V_{dc}$ -related hardware and parameters need to be checked.
- If Flx\_M does not come close to 2048, the “Motor Back EMF Constant (Ke)” needs to be adjusted in MCE Wizard.



**Figure 9** Trace waveform for lu & Flx-M at 50% Speed

- Once the firmware has been programmed, and a new parameter file has to be programmed, follow the same instructions given in 2.1.3. In this case, the firmware programming is no longer needed, and you can select the first option “Program Parameters.”

*Note: For detailed information on controller programming, refer to AN2018-33 iMOTION™ 2.0 Device Programming, MCEDesigner documentation and MCEWizard documentation.*

## 2.2 Description of the functional blocks

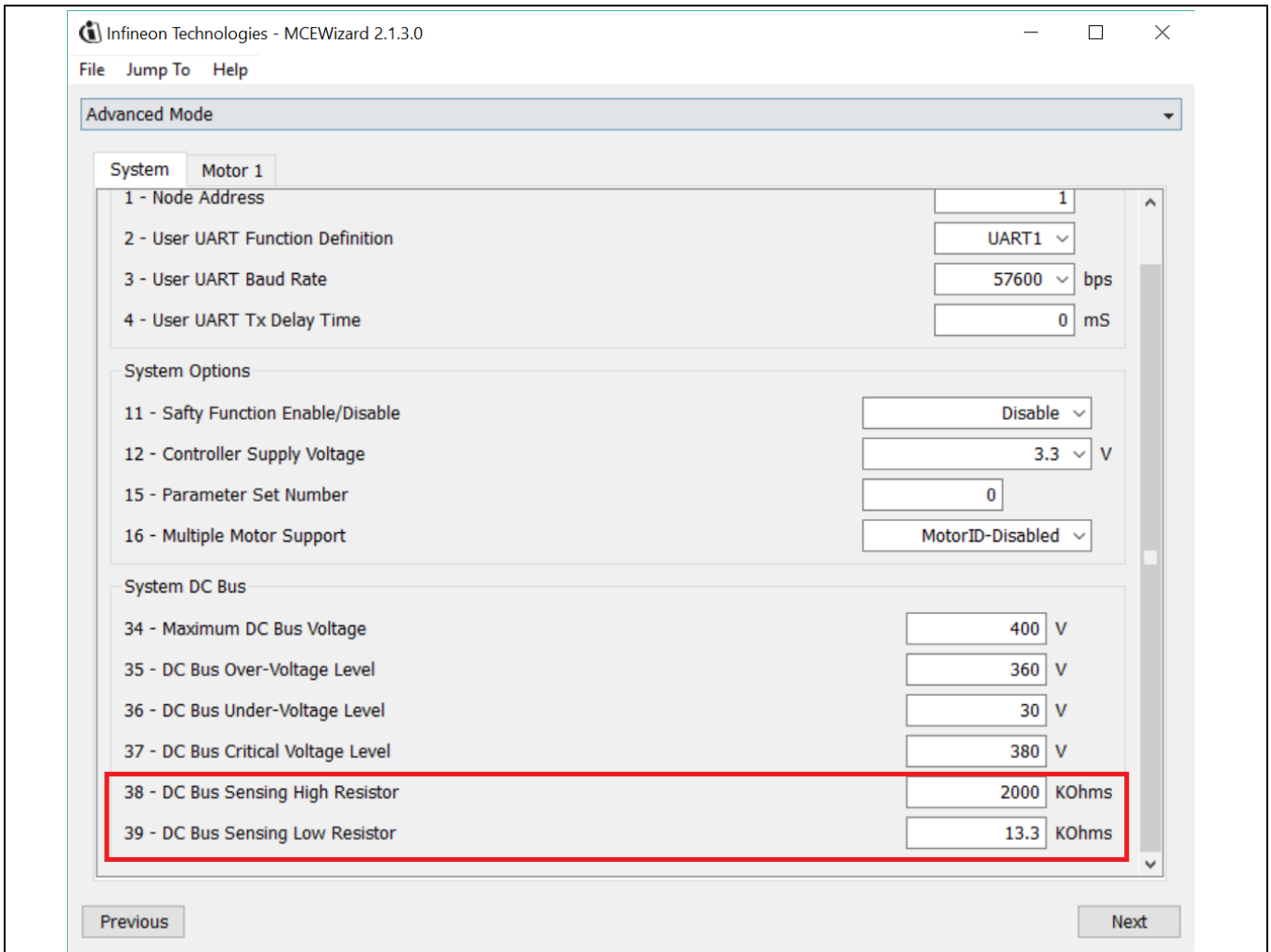
### 2.2.1 IPM

The inverter section is implemented using the CIPOS™ Micro IPM IM241-L6S1B as sketched in Figure 10. IM241-L6S1B is the CIPOS™ Micro 600 V, a 6 A, three-phase IGBT-based intelligent power module with an open emitter in SOP 29x12 packaging. It provides a fully-featured compact inverter solution for low power motor drive applications including refrigerators, small home appliances, low power industrial drives, etc. The module includes a combination of low VCE (sat) trench IGBT technology and the industry-benchmark, rugged half-bridge drivers. More information about this IPM is available in the reference<sup>[2]</sup>.

The current sampling on this board is implemented by single shunt topology with 150 mΩ resistor. The three capacitors C14, C32 and C34 are used as bootstrap capacitors to provide the necessary floating supply voltages VBS1, VBS2 and VBS3, respectively.







**Figure 12 DC bus sensing configuration in MCEWizard**

The time constant of the  $V_{dc}$  sensing low pass filter is  $((R10 + R13) // R15) * C4 = (2 \text{ M}\Omega // 13.3 \text{ k}\Omega) * 4.7 \text{ nF} = 62.1 \mu\text{s}$ . C17 can be adjusted to higher capacitance for clean  $V_{dc}$  sensing.

## 2.2.3 Current sensing and overcurrent protection

### 2.2.3.1 Current sensing

The current sensing on this board uses only the RC network for operational bias and low pass filter to minimize the cost. No additional operational amplifier is needed.

Based on the principle of Kirchhoff's voltage law, and assuming the AD port input impedance is infinite, you obtain the equation below:

$$V_{ADC} = \frac{(V_{cc} - V_{shunt})}{R_1 + R_2} * R_1 + V_{shunt}$$

The equation can be transformed to two parts as shown here:

$$V_{ADC} = \frac{R_2 * V_{shunt}}{R_1 + R_2} + \frac{R_1 * V_{cc}}{R_1 + R_2}$$

The impedance of the RC network is much larger than the  $R_{shunt}$ , so it can be assumed that:

# REF-MHA0K2IMC101T user guide

## Refrigerator compressor driver reference design kit

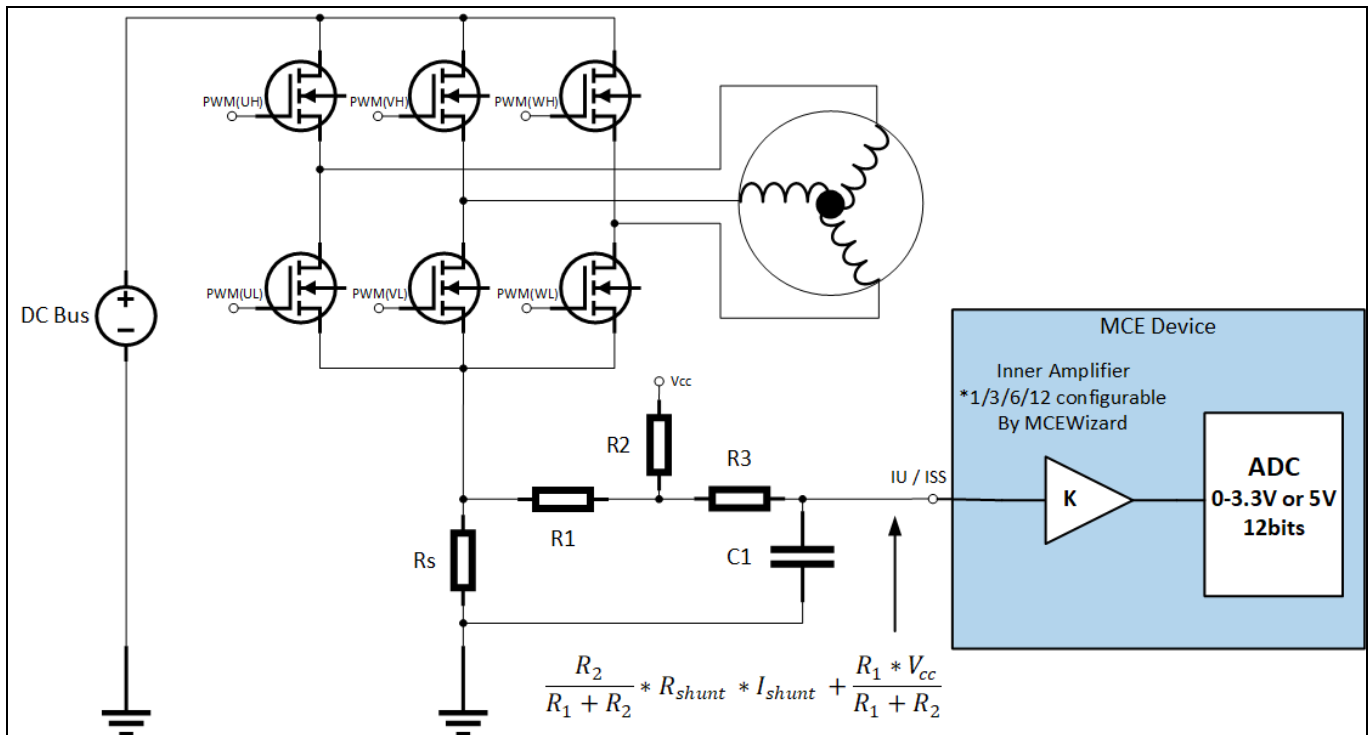
### System and functional description

$$V_{shunt} = I_{shunt} * R_{shunt}$$

$V_{ADC}$  can then be written as:

$$V_{ADC} = \frac{R_2}{R_1 + R_2} * R_{shunt} * I_{shunt} + \frac{R_1 * V_{CC}}{R_1 + R_2}$$

Where  $\frac{R_1 * V_{CC}}{R_1 + R_2}$  is the offset, and  $\frac{R_2}{R_1 + R_2} * R_{shunt}$  is the gain of the shunt current.



**Figure 13** Current sensing topology

Using this board for example,  $R_1 = R_2 = 2 \text{ k}\Omega$ ,  $R_2 = R_8 = 22.1 \text{ k}\Omega$ ,  $V_{CC} = 3.3 \text{ V}$ , offset = 0.274 V, gain =  $\frac{R_2}{R_1 + R_2} * R_{shunt} = 137.6 \text{ mV/A}$ .

Note the following points concerning current sampling:

- $R_8$  &  $R_20$  also determine the ADC operational bias for current sensing, which corresponds to the motor regeneration operation range. For those applications that do not work at regenerative brake mode, the bias can be as low as possible to reserve enough ADC range for the drive mode, since negative current to DC bus does not occur.
- Since the gain of the external RC circuit is less than 1, internal signal amplification is required to increase the ADC input voltage range with the lower shunt value. If a larger shunt is chosen, the power loss and size are both larger. MCE provides an inner current sampling amplifier with \*1, \*3, \*6 and \*12 gain selections, which can be configured in the MCEWizard.
- There is no common mode noise-rejection ability without an outer operational amplifier, so the GND network of the PCB needs to be dealt with very carefully, since any voltage difference between IMC101T's ADC ground and shunt resistor ground will be considered as an "input signal," and will deteriorate control performance or increase audible noise.



## REF-MHA0K2IMC101T user guide

### Refrigerator compressor driver reference design kit

#### System and functional description

##### 1. Internal comparator in the IMC101T

The internal comparator's reference level is set by the internal DAC. The level can be set in the MCEWizard by "Device Overcurrent trigger level setting for Comparator" and "Motor1 Current Input to ADC Offset Voltage." The DAC output pin REFU needs to be connected to a capacitor; 10 nF/16 V is used on the board.

##### 2. Trigger ITRIP pin on the IPM; the fault signal will transfer to the IMC101T by GK pin

The board designs two ways to trigger the ITRIP pin of the IPM, and users can select either one to achieve overcurrent protection.

- Trigger by the comparator U5
- Directly trigger from shunt

Figure 16 shows the ITRIP trigger level which is typically 0.5 V, positive logic. Figure 17 indicates that the inner filter time of ITRIP signal is 500 ns.

ITRIP positive going threshold	$V_{IT,TH+}$	0.475	0.500	0.525	V
ITRIP negative going threshold	$V_{IT,TH-}$	-	0.430	-	V

**Figure 16 IM241-L6S1B ITRIP threshold specification**

Input filter time (ITRIP)	$T_{FIL,ITRIP}$	$V_{IN}=0$ or $V_{IN}=5V$	-	500	-	ns
---------------------------	-----------------	---------------------------	---	-----	---	----

**Figure 17 IM241-L6S1B ITRIP filter time specification**

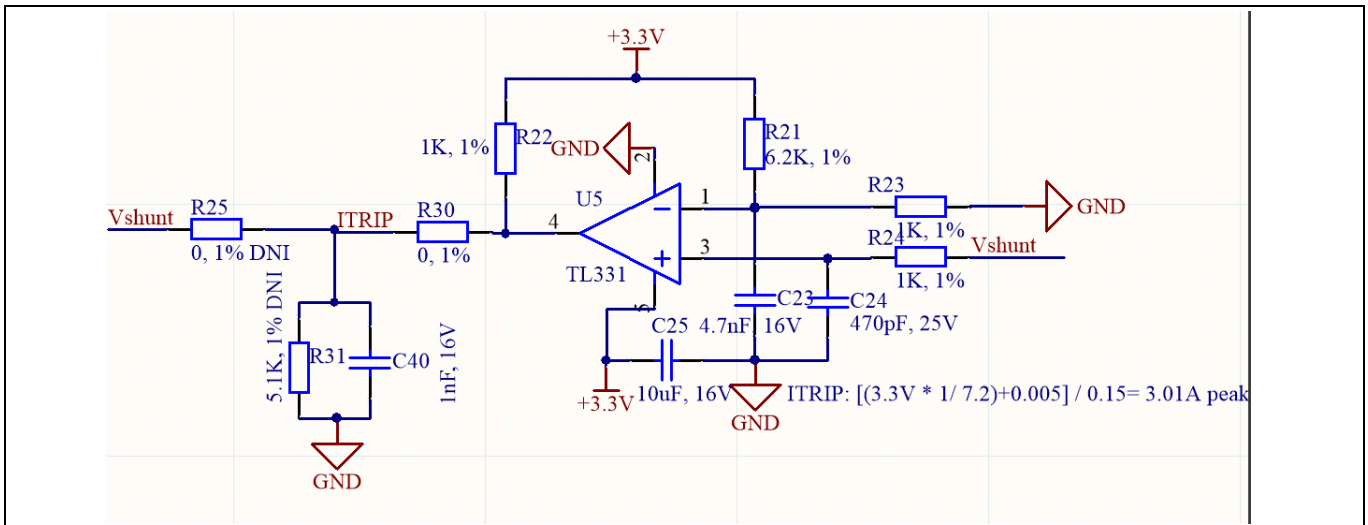
ITRIP to six switch turn-off propagation delay	$T_{ITRIP}$	$V+ = 300V$ , no cap on RFE	-	1.3	-	$\mu s$
--	-------------	-----------------------------	---	-----	---	---------

**Figure 18 IM241-L6S1B ITRIP signal propagation delay time**

Short circuit withstand time	$T_{SC}$	$V_{DD}=15V$ , $V_{DC} \leq 400V$ , $T_J=150^\circ C$ Allowed number of short circuits: <1000, time between short circuit: $\geq 1s$	3	$\mu s$
------------------------------	----------	---	---	---------

**Figure 19 IM241-L6S1B short circuit withstand time**

**REF-MHA0K2IMC101T user guide**  
**Refrigerator compressor driver reference design kit**  
**System and functional description**

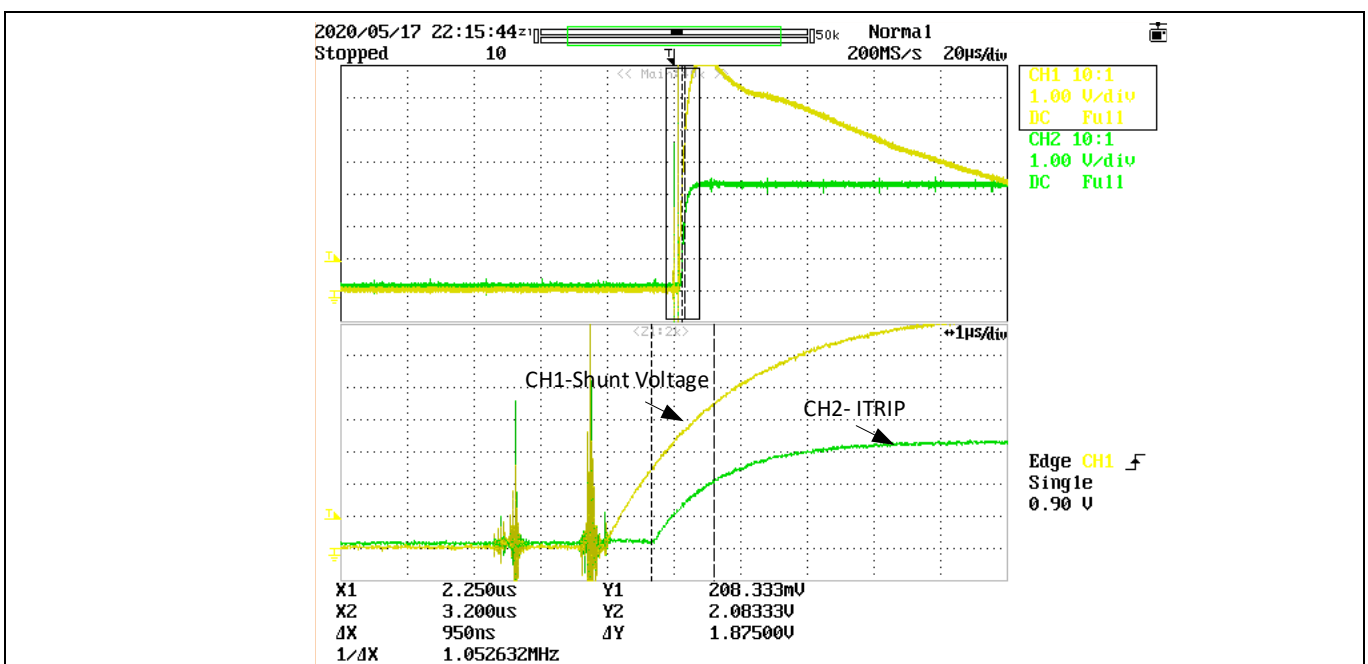


**Figure 20** Current protection circuit to ITRIP of IM241-L1S1B

The default protection circuit on the board is the one triggered by the comparator; it is a more flexible way to set the reference voltage. On this board, we set the voltage as  $3.3\text{ V} * \frac{1\text{ k}\Omega}{6.2\text{ k}\Omega + 1\text{ k}\Omega} = 0.458\text{ V}$ ; the shunt resistor on the board is 150 m $\Omega$ , i.e., the theoretical protection value is 3.05 A peak. The reference voltage can be easily adjusted by the divider resistor.

On the board, R24 = 1 k $\Omega$ , C24 = 470 pF; the filter time constant is  $RC = 1\text{ k}\Omega * 470\text{ pF} = 470\text{ ns}$ ; output part R22 = 1 k $\Omega$ , C40 = 1 nF; the filter time constant is  $RC = 1\text{ k}\Omega * 1\text{ nF} = 1\text{ }\mu\text{s}$ . Therefore, the total delay time is about 1.5  $\mu\text{s}$ .

Figure 21 shows the waveform of the comparator. CH1 is the shunt voltage and CH2 connection to the ITRIP pin of the IPM. You might find that the ITRIP signal time - from 0 to 63.2% (0 - 2.08 V) - is about 0.95  $\mu\text{s}$ , which is close to the theoretical value of 1  $\mu\text{s}$ , and notice that the ITRIP trigger level is only 0.5 V. Therefore, the total response time of the comparator is about 1  $\mu\text{s}$ , plus the added propagation delay time of 1.3  $\mu\text{s}$  in Figure 18 equals a total time of about 2.3  $\mu\text{s}$ , which is only 80% of the short-circuit withstand time of 3  $\mu\text{s}$  in Figure 19.



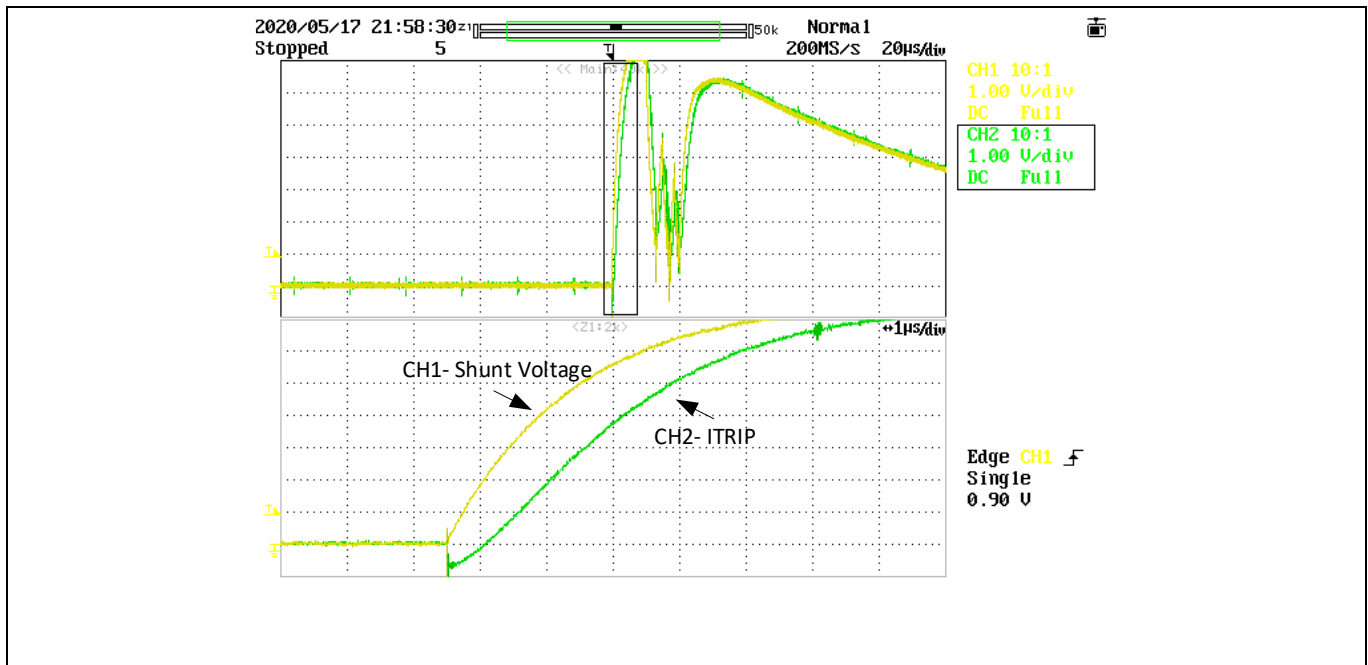
**Figure 21** Dynamic response of the protection circuit with comparator

# REF-MHA0K2IMC101T user guide

## Refrigerator compressor driver reference design kit

### System and functional description

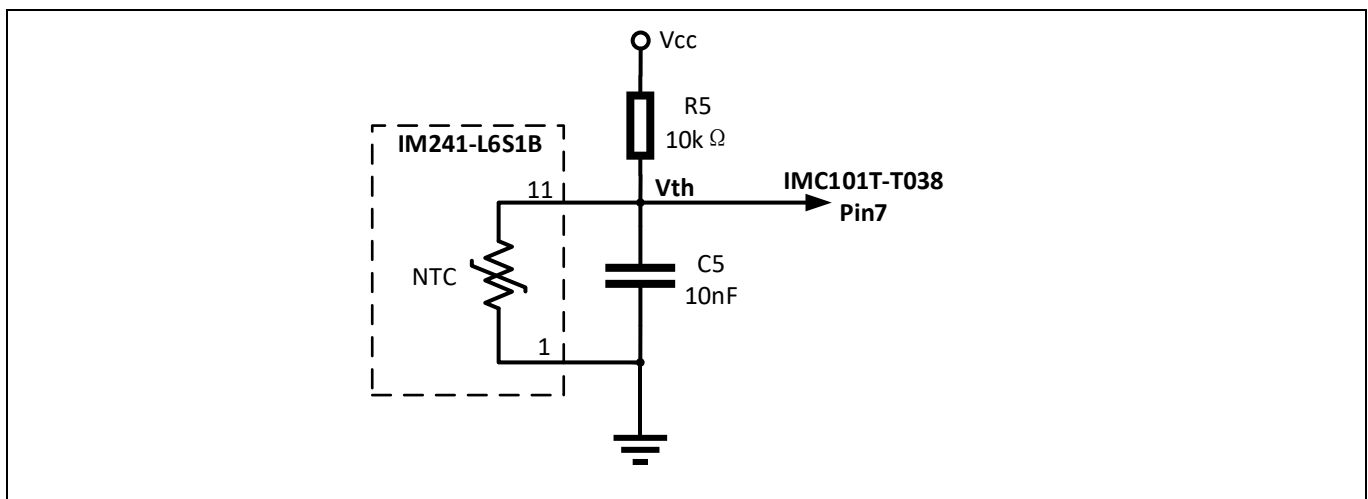
Another way to trigger the ITRIP is to directly connect the shunt to the ITRIP as indicated in Figure 22. It needs to disconnect the output of the comparator U5 by removing R30 and soldering R25. If  $R_{25} = 1\text{ k}\Omega$ , the RC filter time constant will equal the RC, which is  $1\mu\text{s}$ . Figure 22 shows the test waveform.



**Figure 22** Dynamic response of the protection circuit when directly connecting to shunt

### 2.2.4 NTC sensing and thermal protection

Pin 7 of IMC101T-T038 is the ADC port dedicated to NTC temperature sampling. On the board, Pin 11 of the IPM IM241-L6S1B is connected to the ADC channel by the circuit shown in Figure 23.



**Figure 23** NTC sensing circuit

Referring to the datasheet of IM241 series IPM <sup>[1]</sup>, the parameters of the thermistor can be obtained. The B-constant is  $4006\text{ K} \pm 1\%$ ,  $R_{25} = 47\text{ k}\Omega \pm 5\%$ . Based on the typical value of the thermistor resistance, voltage of the  $V_{th}$  can be obtained in Table 4.

**Table 4 Thermistor characteristics with  $V_{cc} = 3.3\text{ V}$**

Temperature(°C)	Resistance typ. (kΩ)	$V_{th}$ (mV)
50	16.43	2.05
60	11.19	1.74
70	7.77	1.44
80	5.48	1.17
90	3.94	0.93
100	2.87	0.74
110	2.13	0.58
120	1.59	0.45
125	1.38	0.40

The firmware inside the IMC101T integrates the over-temperature protection function, which is triggered by the voltage  $V_{th}$ . The only thing to do is to set the proper trigger level in the MCEWizard. More information can be found in the over-temperature protection section of the reference material [7].

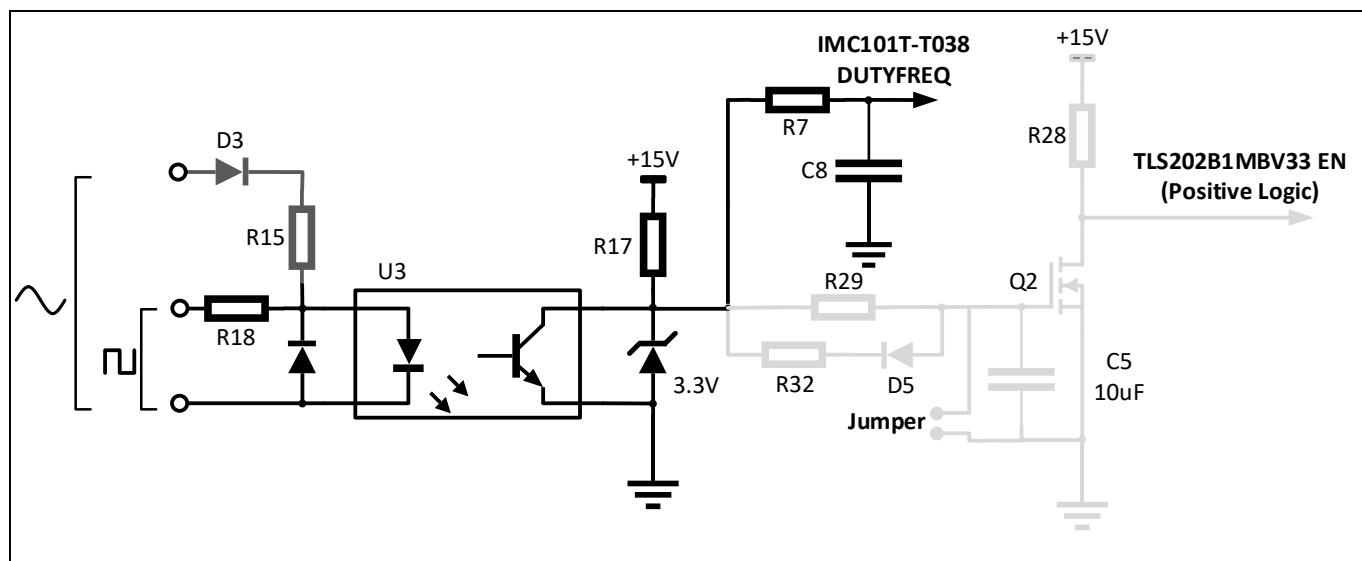
### 2.3 Frequency signal interface

Since current refrigerator applications mainly use frequency signals to control the compressor speed, the board is designed with a frequency signal interface. Figure 24 shows the interface circuit. The input signal is isolated from the control and power parts on the board.

The board have two types of input interface:

- Square wave interface (default, remove the D3, R15)
- AC 220V as the control input (you need to remove R18, and install D3, R15)

Type one is a more common signal type, while type two is used less, leaving only the interface for customers who need it.



**Figure 24 Frequency interface circuit**

The optocoupler output is pulled up to 15 V, because the board uses the output signal to control the linear voltage regulator TLS202B1MBV33. If this function is not needed, the user can use the 3.3 V/5 V to pull up. The

**System and functional description**

grey part of the circuit is used to control the Enable/Disable of the linear voltage regulator, which can be disabled during no control signal input. The detail will be introduced in Section 2.4.

A typical square wave input signal for refrigerator applications is shown in Table 5 for reference.

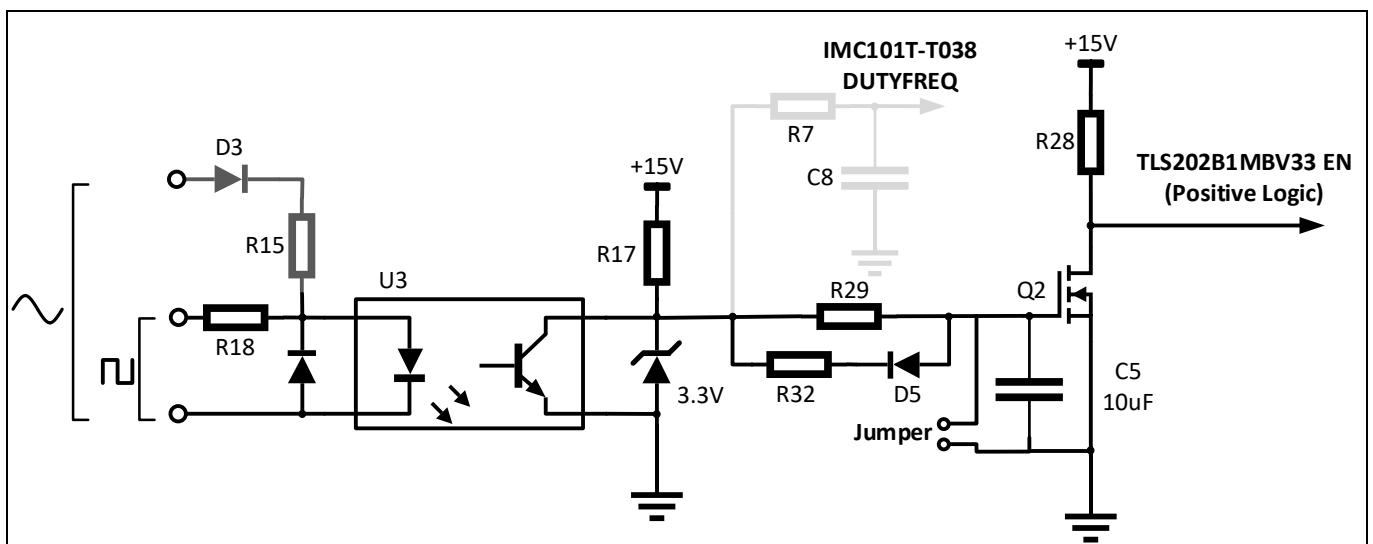
**Table 5 Typical frequency/speed characteristic**

Signal frequency $f_n$ (Hz)	Motor speed $n$ (RPM)
$f_n < 30$	Stop
$30 \leq f_n < 40$	Minimum speed
$40 \leq f_n < 150$	$30 * f_n$
$150 \leq f_n < 200$	Maximum speed
$f_n \geq 200$	Stop

**2.4 Linear voltage regulator and control**

Considering the requirements for standby power consumption in refrigerator applications, the board selects a linear power supply with an Enable function. The part number of this linear voltage regulator is TLS202B1MBV33 which is also an Infineon product. On the board, we have designed the circuit to transfer the Frequency signal to enable signal as shown in Figure 25. If you do not need this function, jump the jumper J5 on the board so that the linear voltage regulator is always on Enable.

Here is a brief explanation of the principle of the circuit: TLS202B1MBV33’s Enable signal is positive logic, which means high level input enable the 3.3 V output. If there is no frequency signal input, the gate drive voltage of Q2 is high, which means the Q2 is on, the Enable signal is low so that the LDO of 3.3 V is disabled. If there is a frequency signal input, the charge in the capacitor C5 will discharge through the D5-R32-U3 during the high level input, and charge through R27, R29. When the voltage of capacitor C5 drops down to the gate threshold voltage of Q2, the Q2 will shut down, and the Enable signal will be high, so the LDO of 3.3 V will be enabled.



**Figure 25 TLS202B1MBV33 Enable function control circuit**



### 3 Details of the schematics, layout, BOM and connectors

This section provides the complete details of the schematics, layout and connectors. Please note that the schematics, routing and Gerber generation are done in Altium designer. Customers who are interested in the original Altium format files or pdf files for better clarity can visit <http://www.infineon.com>.

#### 3.1 Schematics

The major function blocks are introduced in the Section 2.2. Customers who are interested in the further details can download the design files after logging in your account on Infineon webpage.

#### 3.2 Layout

The board is designed in two layers, and its dimensions are 78 mm × 78 mm, manufactured with 1 oz. (35 μm) copper thickness. The project is designed with Altium Designer, and all design files can be downloaded after logging in your account on Infineon webpage.

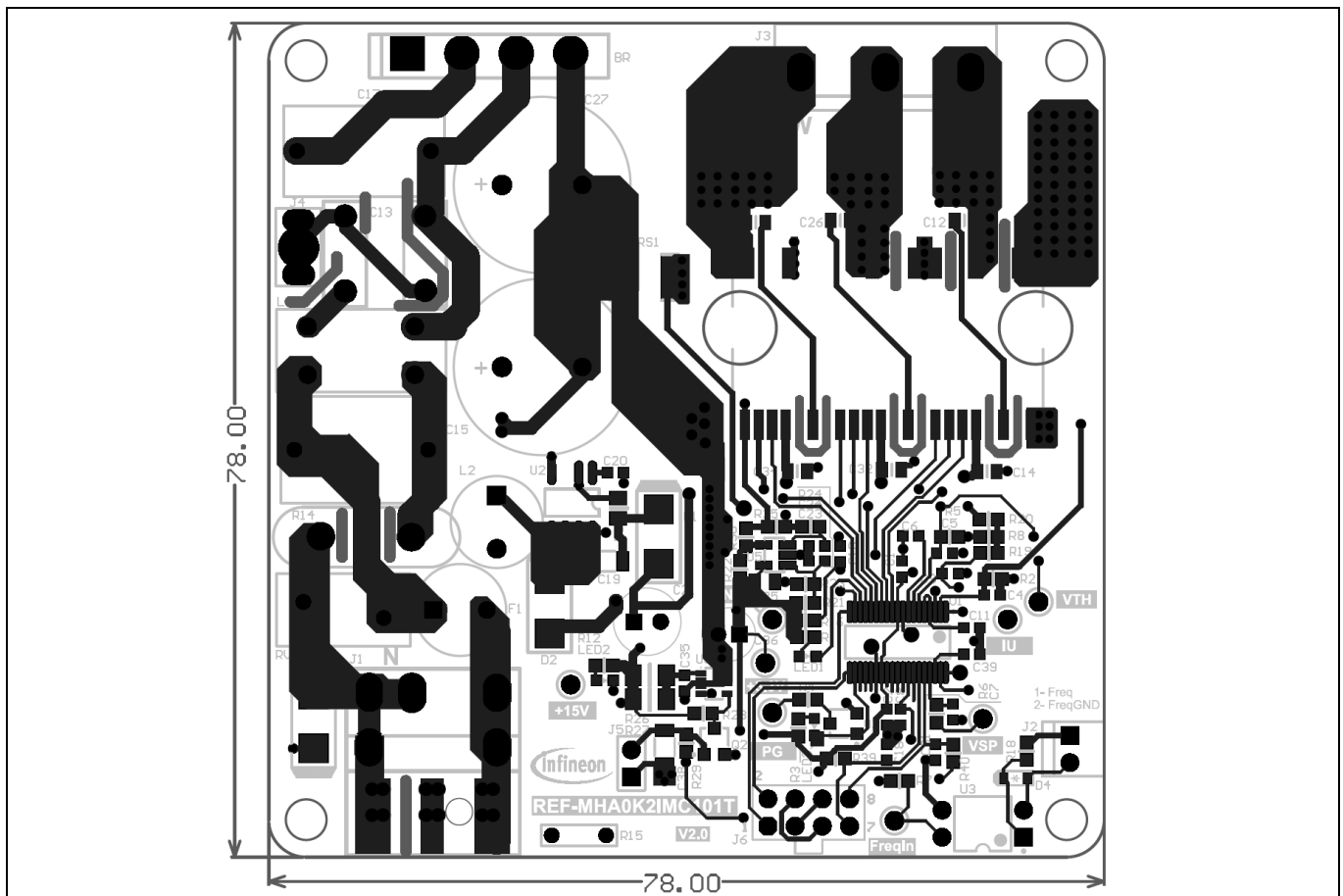
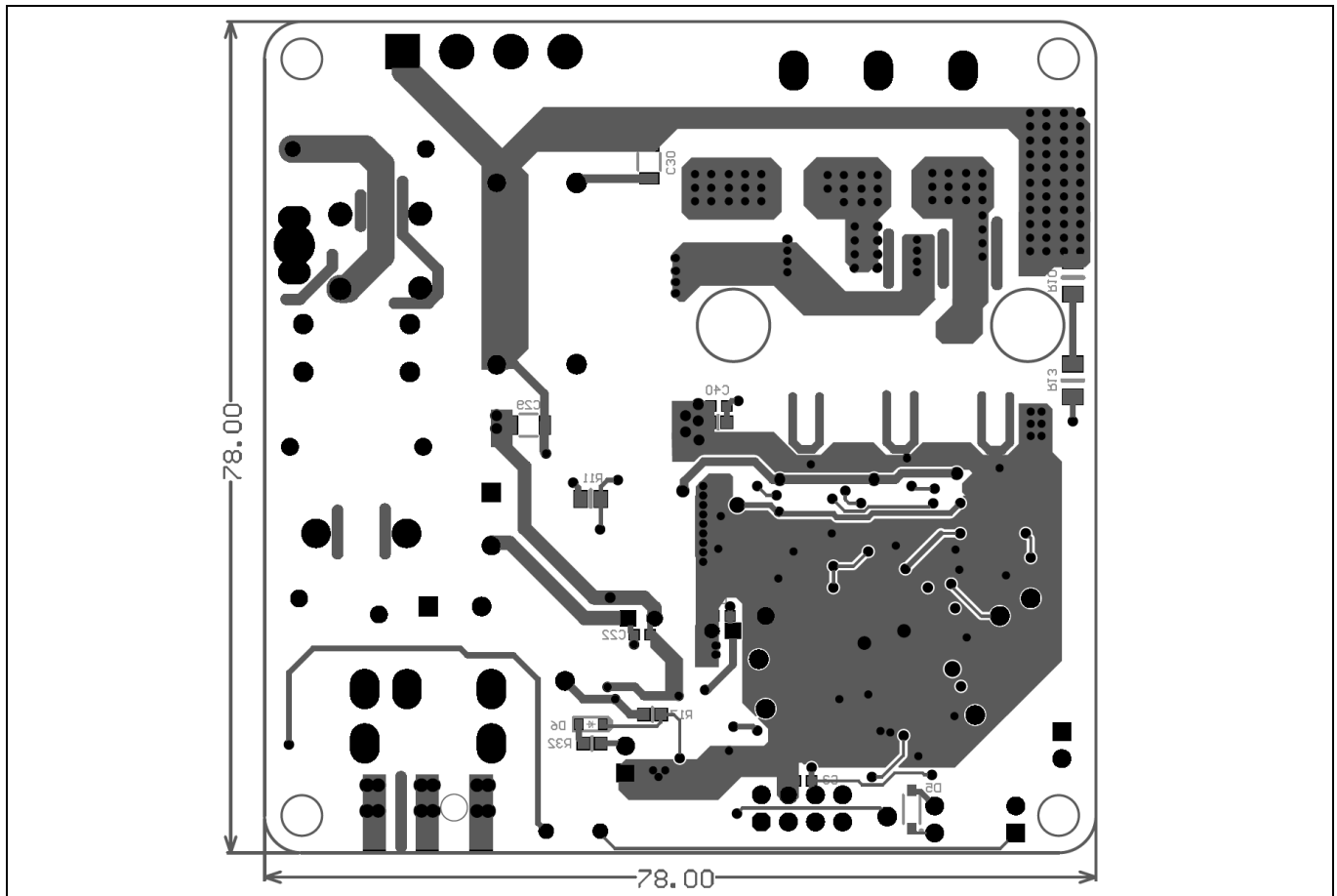


Figure 26 Top view of the board



**Figure 27 Bottom view of the board**

Here are a few design tips to note for your reference.

- Thermal performance of the IPM

Pin17 (DCP) /18 (U)/21 (V)/23 (W) of the IPM are the terminals for directly connecting the lead frame. Maximizing the copper area of these pins could effectively reduce the IGBT junction temperature.

- Ground layout

Since current sampling is non-differential and without op-amp, the area should be carefully laid out; the digital ground should refer to the shunt ground to ensure sampling noise is correct.

### **3.3 Bill of material**

The complete bill of material is available on the download section of the Infineon homepage. A log-in is required to download this material.

**Table 6 The most critical parts of the reference board**

S. No.	Ref designator	Description	Manufacturer	Manufacturer P/N
1	U1	IC MOTOR DRIVER 3V-5.5 V TSSOP-38	Infineon Technologies	IMC101TT038XUMA1
2	U4	IPM CIPOS MICRO	Infineon Technologies	IM241-L6S1B
3	U6	IC REG LINEAR 3.3 V 150 mA SCT595	Infineon Technologies	TLS202B1MBV33
4	Q1, Q2	MOSFET N-CH 30 V 2.7 A SOT-23-3	Infineon Technologies	IRLML2030TRPBF
5	C15	WCAP-FTX2 Film Capacitors, 15x10x16 mm, 275 V AC, 470 nF	Würth Elektronik	890324024005
6	C17	WCAP-FTX2 Film Capacitors, 15x8.5x14 mm, 275 V AC, 330 nF	Würth Elektronik	890324024003
7	C21	WCAP-ATG8 Aluminum Electrolytic Capacitors, 6.3x11 mm, 25 Vdc, 220 uF	Würth Elektronik	860010473011
8	C36	WCAP-ATG8 Aluminum Electrolytic Capacitors, 5x11 mm, 16 Vdc, 100 uF	Würth Elektronik	860010372006
9	J2	WR-WTB 2.54 mm Male Locking Header, 2p	Würth Elektronik	61900211121
10	L1	WE-CMB Common Mode Power Line Choke, Type XS, 4 mH, 1.5 A, 250 V	Würth Elektronik	744821240
11	RV1	WE-VD Disk Varistor, size 10 mm, 300 Vrms, 385 Vdc	Würth Elektronik	820513011
12	C27, C28	WCAP-AT1H THT Aluminum Electrolytic Capacitors, D16 mm x L35.5 mm, 100 uF, +/- 20%, 450 VDC	Würth Elektronik	860241480001
13	C29, C30	WCAP-CSST Soft Termination Ceramic Capacitors, size 1206, 22 nF, +/- 10%, 500 VDC	Würth Elektronik	885382208010
14	J5	CONN HEADER VERT 2 POS 2.54 MM	Würth Elektronik	150060RS75000

### 3.4 Connector details

**Table 7 J1- AC Line connector**

PIN	Label	Function
1	L	AC line input
2	N	AC neutral input
3	N	AC neutral input

**Table 8 J2- Frequency input signal connector**

PIN	Label	Function
1	Frequency input	Frequency input signal, isolated by optocoupler
2	Frequency ground	Frequency input signal ground, isolated by optocoupler

**Table 9 J3- Motor side connector**

PIN	Label	Function
1	U	Connected to motor phase U
2	V	Connected to motor phase V
3	W	Connected to motor phase W

**Table 10 J4- Earth connector**

PIN	Label	Function
1	Earth	

**Table 11 J5- Jumper**

PIN	Label	Function
1	MOSFET's Gate	Short pin 1 and 2 will enable 3.3 V directly, otherwise 3.3 V is controlled by frequency signal.
2	Ground	

**Table 12 J6- iMOTION™ Link connector**

PIN	Label	Function
1	TXD1	User UART for script communication
2	RXD1	User UART for script communication
3 & 6	+3.3V	On board 3.3 V supply
4 & 5	GND	Ground
7	RXD0	MCEDesigner & firmware download
8	TXD0	MCEDesigner & firmware download

System performance

## 4 System performance

### 4.1 Thermal characterization test

Figure 28 and Figure 29 show the thermal characterizations of REF-MHA0K2IMC101T, based on 2 layers FR4 PCB with 1 oz. copper.

The tests reported on were performed under the following conditions:  $t_{amb}=25^{\circ}\text{C}$ ,  $V_{ac} = 220\text{ V}$ ,  $f_{PWM} = 5\text{ kHz}$ , with different input power until the IPM case reaches  $100^{\circ}\text{C}$ .

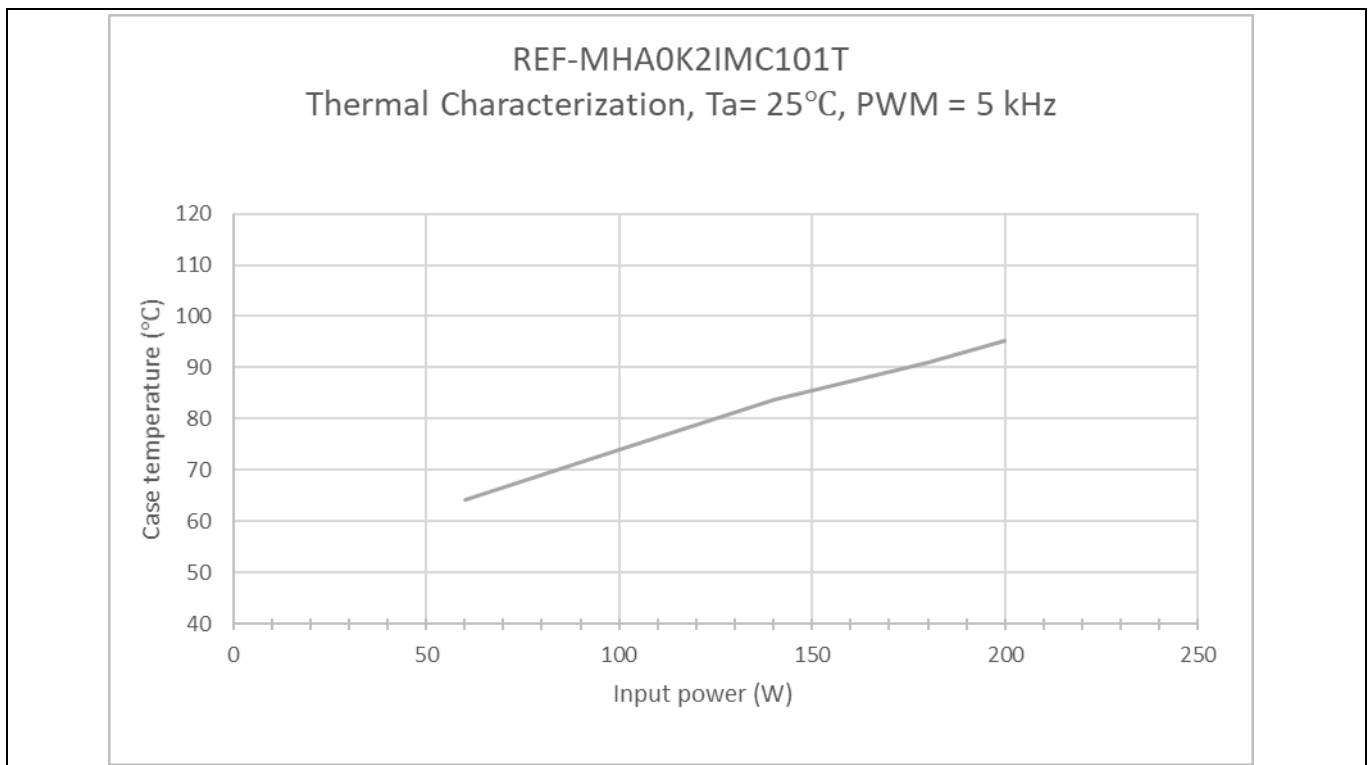


Figure 28 REF-MHA0K2IMC101T thermal characterization case temperature - input power,  $t_{amb} = 25^{\circ}\text{C}$

Table 13 Input power and current characterization

Input power (W)	60	100	140	180	200
Input current (A)	0.45	0.72	1.03	1.32	1.5

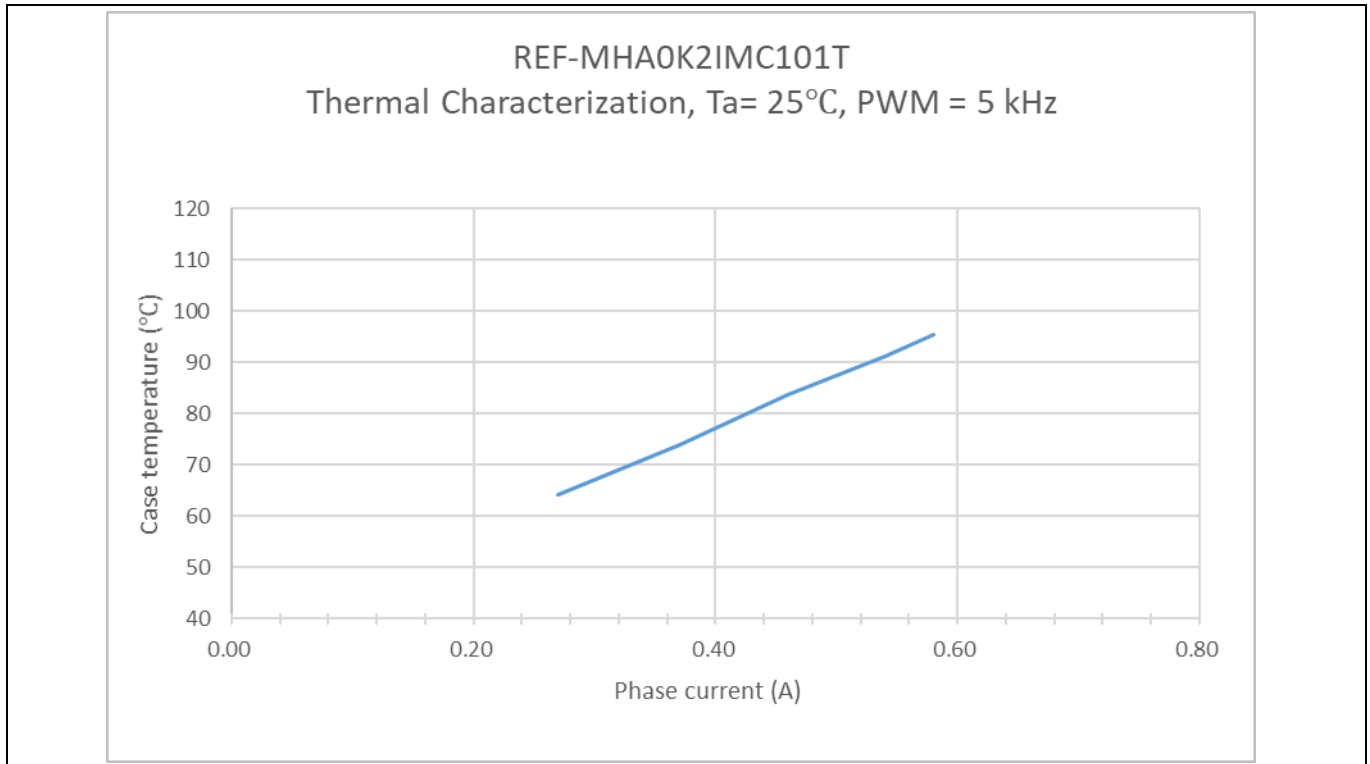


Figure 29 REF-MHA0K2IMC101T thermal characterization, case temperature - motor phase current,  $t_{amb} = 25^{\circ}\text{C}$

## 5 Reference and appendices

### 5.1 Abbreviations and definitions

**Table 14** Abbreviations

Abbreviation	Meaning
BLDC	Brushless direct current motor
CIPOS	Control integrated power system
FOC	Field oriented control
IPM	Intelligent power module
UL	Underwriters Laboratories
PMSM	Permanent magnet synchronous motor

### 5.2 Reference

- [1] Infineon Technologies AG. Datasheet of Infineon IM241-L6S1B (2022). V1.6 [www.infineon.com](http://www.infineon.com)
- [2] Infineon Technologies AG. Datasheet of Infineon IMC101T-T038 (2019). V1.4 [www.infineon.com](http://www.infineon.com)
- [3] Infineon Technologies AG. Datasheet of Infineon TLS202B1MBV33 (2015). V1.0 [www.infineon.com](http://www.infineon.com)
- [4] Infineon Technologies AG. Datasheet of IRLM2030TRPbF (2009) [www.infineon.com](http://www.infineon.com)
- [5] Infineon Technologies AG. MCEWizard\_V2.3.0.0 User Guide (2019) [www.infineon.com](http://www.infineon.com)
- [6] Infineon Technologies AG. MCEDesigner\_V2.3.0.0 Application Guide (2019) [www.infineon.com](http://www.infineon.com)
- [7] Infineon Technologies AG. iMOTION™ Motion Control Engine Software Reference Manual (2020) V1.3 [www.infineon.com](http://www.infineon.com)

### 5.3 Additional information

In order to initiate testing, customers are advised to order the iMOTION™ Link, the information is listed in the Table 15.

The Infineon's components on the board are listed in the Table 15 as well, the customers can visit the corresponding webpage for more information.

**Table 15** Additional information of tools and Infineon's components

Base part number	Package	Standard pack		Orderable part number
		Form	Quantity	
<a href="#">iMOTION™ Link</a>		Container	1	IMOTIONLINK
<a href="#">IMC101T-T038</a>	PG-TSSOP-38-9	Tape and reel	3000	IMC101TT038XUMA1
<a href="#">IM241-L6S1B</a>	SOP 29x12	Tape and reel	500	IM241L6S1BAUMA1
<a href="#">TLS202B1MBV33</a>	PGSCT595	Tape and reel	3000	TLS202B1MBV33HTSA1
<a href="#">IRLML2030TRPBF</a>	SOT-23	Tape and reel	3000	IRLML2030TRPBF

**Revision history**

**Revision history**

<b>Document version</b>	<b>Date of release</b>	<b>Description of changes</b>
1.0	2020-09-29	First release
2.0	2022-10-15	Update IM231- L6S1B with IM241- L6S1B Update IFX54211MB with TLS202B1MBV33



**Trademarks**

All referenced product or service names and trademarks are the property of their respective owners.

**Edition 2022-10-15**

**Published by**

**Infineon Technologies AG**

**81726 Munich, Germany**

**© 2022 Infineon Technologies AG.**

**All Rights Reserved.**

**Do you have a question about this document?**

**Email: [erratum@infineon.com](mailto:erratum@infineon.com)**

**Document reference**

**UG-2022-13**

For further information on the product, technology, delivery terms and conditions and prices please contact your nearest Infineon Technologies office ([www.infineon.com](http://www.infineon.com)).

**WARNINGS**

Due to technical requirements products may contain dangerous substances. For information on the types in question please contact your nearest Infineon Technologies office.

Except as otherwise explicitly approved by Infineon Technologies in a written document signed by authorized representatives of Infineon Technologies, Infineon Technologies' products may not be used in any applications where a failure of the product or any consequences of the use thereof can reasonably be expected to result in personal injury.