

# REF-SHA35IMD111TSYS User guide

## Full-featured starter kit for low voltage ceiling fan motor drive design

### About this document

#### Scope and purpose

This user guide provides a detailed description of the reference board REF-SHA35IMD111TSYS including its main features, design guidelines, and test results.

REF-SHA35IMD111TSYS is a turnkey solution for low-voltage brushless direct current (BLDC) motor drive for ceiling fan applications with high efficiency, high power factor (PF), and excellent motor control performance.

Based on the highly integrated iMOTION™ driver IMD111T-6F040 that includes the advanced motion control engine (MCE 2.0) technology, and the newly promoted integrated motor control development tool iMOTION™ Solution Designer (iSD), the REF-SHA35IMD111TSYS provides an easy-to-use design reference that helps decrease time-to-market by eliminating the need for developing own motor control software.

*Note: Please note that this product is not qualified according to the AEC Q100 or AEC Q101 documents from the Automotive Electronics Council.*

#### Intended audience

This user guide is intended for all technical specialists who are familiar with low-voltage ceiling fan control and inverters. The reference design is intended to be used under laboratory conditions only by trained specialists.

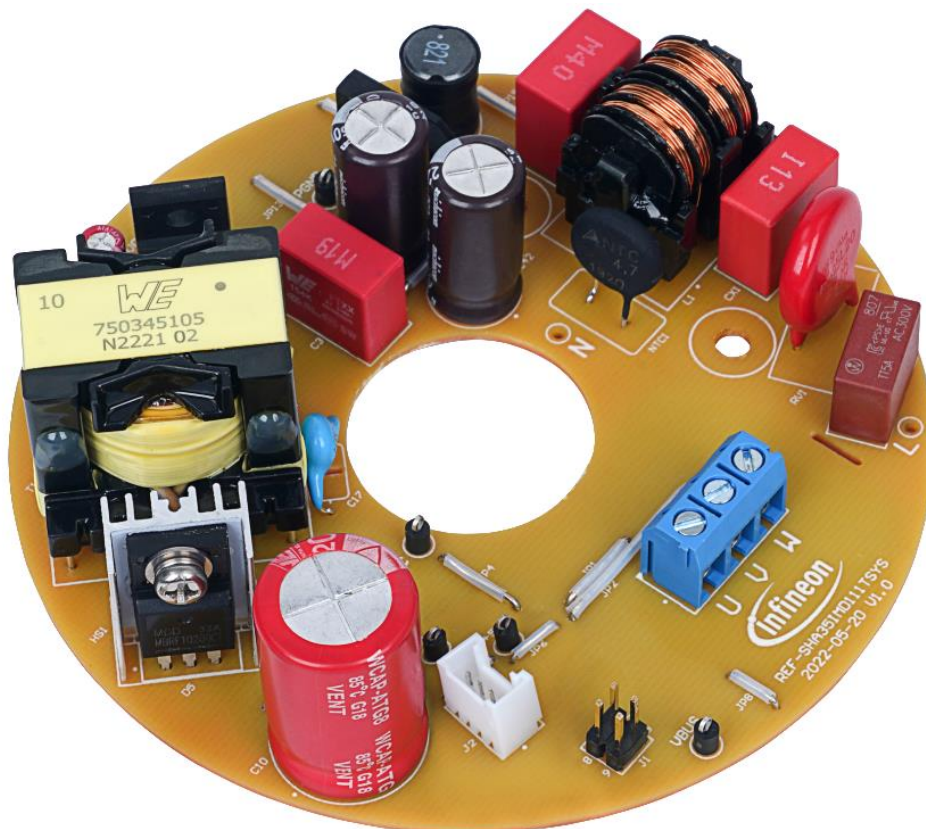

### Important notice

### Important notice

**“Evaluation Boards and Reference Boards” shall mean products embedded on a printed circuit board (PCB) for demonstration and/or evaluation purposes, which include, without limitation, demonstration, reference and evaluation boards, kits and design (collectively referred to as “Reference Board”).**

**Environmental conditions have been considered in the design of the Evaluation Boards and Reference Boards provided by Infineon Technologies. The design of the Evaluation Boards and Reference Boards has been tested by Infineon Technologies only as described in this document. The design is not qualified in terms of safety requirements, manufacturing and operation over the entire operating temperature range or lifetime.**

**The Evaluation Boards and Reference Boards provided by Infineon Technologies are subject to functional testing only under typical load conditions. Evaluation Boards and Reference Boards are not subject to the same procedures as regular products regarding returned material analysis (RMA), process change notification (PCN) and product discontinuation (PD).**

**Evaluation Boards and Reference Boards are not commercialized products, and are solely intended for evaluation and testing purposes. In particular, they shall not be used for reliability testing or production. The Evaluation Boards and Reference Boards may therefore not comply with CE or similar standards (including but not limited to the EMC Directive 2004/EC/108 and the EMC Act) and may not fulfill other requirements of the country in which they are operated by the customer. The customer shall ensure that all Evaluation Boards and Reference Boards will be handled in a way which is compliant with the relevant requirements and standards of the country in which they are operated.**

**The Evaluation Boards and Reference Boards as well as the information provided in this document are addressed only to qualified and skilled technical staff, for laboratory usage, and shall be used and managed according to the terms and conditions set forth in this document and in other related documentation supplied with the respective Evaluation Board or Reference Board.**

**It is the responsibility of the customer’s technical departments to evaluate the suitability of the Evaluation Boards and Reference Boards for the intended application, and to evaluate the completeness and correctness of the information provided in this document with respect to such application.**

**The customer is obliged to ensure that the use of the Evaluation Boards and Reference Boards does not cause any harm to persons or third party property.**

**The Evaluation Boards and Reference Boards and any information in this document is provided "as is" and Infineon Technologies disclaims any warranties, express or implied, including but not limited to warranties of non-infringement of third party rights and implied warranties of fitness for any purpose, or for merchantability.**

**Infineon Technologies shall not be responsible for any damages resulting from the use of the Evaluation Boards and Reference Boards and/or from any information provided in this document. The customer is obliged to defend, indemnify and hold Infineon Technologies harmless from and against any claims or damages arising out of or resulting from any use thereof.**

**Infineon Technologies reserves the right to modify this document and/or any information provided herein at any time without further notice.**

## Safety precautions

## Safety precautions

Note: Please note the following warnings regarding the hazards associated with development systems.

Table 1 Safety precautions

	<p><b>Warning:</b> The DC link potential of this board is up to 600 VDC. When measuring voltage waveforms by oscilloscope, high voltage differential probes must be used. Failure to do so may result in personal injury or death.</p>
	<p><b>Warning:</b> The evaluation or reference board contains DC bus capacitors which take time to discharge after removal of the main supply. Before working on the drive system, wait five minutes for capacitors to discharge to safe voltage levels. Failure to do so may result in personal injury or death. Darkened display LEDs are not an indication that capacitors have discharged to safe voltage levels.</p>
	<p><b>Warning:</b> The evaluation or reference board is connected to the grid input during testing. Hence, high-voltage differential probes must be used when measuring voltage waveforms by oscilloscope. Failure to do so may result in personal injury or death. Darkened display LEDs are not an indication that capacitors have discharged to safe voltage levels.</p>
	<p><b>Warning:</b> Remove or disconnect power from the drive before you disconnect or reconnect wires, or perform maintenance work. Wait five minutes after removing power to discharge the bus capacitors. Do not attempt to service the drive until the bus capacitors have discharged to zero. Failure to do so may result in personal injury or death.</p>
	<p><b>Caution:</b> The heat sink and device surfaces of the evaluation or reference board may become hot during testing. Hence, necessary precautions are required while handling the board. Failure to comply may cause injury.</p>
	<p><b>Caution:</b> Only personnel familiar with the drive, power electronics and associated machinery should plan, install, commission and subsequently service the system. Failure to comply may result in personal injury and/or equipment damage.</p>
	<p><b>Caution:</b> The evaluation or reference board contains parts and assemblies sensitive to electrostatic discharge (ESD). Electrostatic control precautions are required when installing, testing, servicing or repairing the assembly. Component damage may result if ESD control procedures are not followed. If you are not familiar with electrostatic control procedures, refer to the applicable ESD protection handbooks and guidelines.</p>
	<p><b>Caution:</b> A drive that is incorrectly applied or installed can lead to component damage or reduction in product lifetime. Wiring or application errors such as undersizing the motor, supplying an incorrect or inadequate AC supply, or excessive ambient temperatures may result in system malfunction.</p>
	<p><b>Caution:</b> The evaluation or reference board is shipped with packing materials that need to be removed prior to installation. Failure to remove all packing materials that are unnecessary for system installation may result in overheating or abnormal operating conditions.</p>

## Table of contents

## Table of contents

<b>About this document</b> .....	<b>1</b>
<b>Important notice</b> .....	<b>2</b>
<b>Safety precautions</b> .....	<b>3</b>
<b>Table of contents</b> .....	<b>4</b>
<b>1 The board at a glance</b> .....	<b>6</b>
1.1 Main features .....	6
1.2 Delivery content .....	6
1.3 Block diagram.....	7
1.4 Board specification .....	10
<b>2 Schematics</b> .....	<b>12</b>
<b>3 Layout</b> .....	<b>15</b>
<b>4 Bill of material</b> .....	<b>17</b>
<b>5 Connectors</b> .....	<b>22</b>
5.1 Main board connectors .....	22
5.2 IR companion board connectors .....	22
<b>6 Design description</b> .....	<b>23</b>
6.1 AC/DC converter .....	23
6.1.1 EMI filter and surge protection .....	23
6.1.2 Transformer design .....	23
6.1.3 ICL8810 configuration .....	24
6.1.4 Power supply to ICL8810.....	25
6.1.5 Feedback loop.....	25
6.2 3-phase inverter and control .....	26
6.2.1 3-phase inverter .....	26
6.2.2 DC bus voltage sensing .....	27
6.2.3 Motor Current sensing .....	28
6.2.4 Motor overcurrent protection (OCP) .....	30
6.3 IMD111T-6F040 .....	30
6.3.1 Power supply of IMD111T-6F064 .....	30
6.3.2 Bootstrap capacitors.....	31
6.4 Infrared remote control .....	32
6.4.1 Infrared signal processing on the companion board.....	32
6.4.2 Infrared signal input on the main board .....	34
<b>7 System setup</b> .....	<b>35</b>
7.1 System connection.....	35
7.2 iMOTION™ development tool.....	36
7.2.1 iMOTION™ Solution Designer and SDpak.....	36
7.2.2 Key parameters configuration in iSD.....	36
7.3 Script code of the infrared remote control .....	37
7.3.1 Infrared remote control and speed setting.....	37
7.3.2 Description of the script code.....	37
<b>8 Test results</b> .....	<b>39</b>
8.1 System test with IR remote control .....	39
8.2 Voltage stress of the AC/DC MOSFET and rectifier diode.....	41
8.3 DC bus, VCC, and VDD regulation at power ON/OFF .....	42



**Table of contents**

8.4 Gate drive and voltage stress of the inverter MOSFET..... 43

8.5 Motor running performance ..... 44

8.5.1 Motor startup from zero-speed ..... 44

8.5.2 Motor forward catch-spin ..... 45

8.6 Protection..... 46

8.7 Thermal performance ..... 46

8.8 Surge..... 47

**9 Appendices..... 48**

9.1 The transformer specification ..... 48

9.2 Abbreviations and definitions..... 49

9.3 Additional information..... 49

9.4 Script code..... 49

**10 References ..... 56**

**Revision history..... 57**

**Disclaimer..... 58**

**The board at a glance**

# 1 The board at a glance

*Note: Environmental conditions have been considered in the design of REF-SHA35IMD111TSYS. The design was tested as described in this document, but not qualified in terms of safety requirements or manufacturing and operation over the whole operating temperature range or lifetime. The boards provided by Infineon are subject to functional testing only. The boards are not subject to the same procedures as regular products in terms of returned material analysis (RMA), process change notification (PCN) and product discontinuation (PD).*

## 1.1 Main features

The kit includes the following main features:

- Wide AC input range of 90~300 V<sub>rms</sub>
- High PF value of > 0.95 with total harmonic distortion (THD) < 10% at maximum load
- High efficiency of > 85% at maximum load
- Standby power <1 W
- 4 kV L-N surge test compliant according to IEC61000-4-5
- Excellent motor control performance based on the iMOTION™ MCE 2.0 technology
- Infrared remote control with Save-last-speed-setting feature
- Protections including input brown-in/out, overvoltage, and overcurrent (DC bus and motor)
- Single-layer printed circuit board (PCB) for a compact and low-cost design
- RoHS compliant

## 1.2 Delivery content

The reference board REF-SHA35IMD111TSYS is delivered with a companion board containing an infrared (IR) interface.

The delivery content is listed in Table 2.

**Table 2 Delivery content**

Base part number	Package	Standard pack		Orderable part number
		Form	Quantity	
REF-SHA35IMD111TSYS		Boxed	1	REFSHA35IMD111TSYSTOBO1
IR companion board		Boxed	1	
Cable		Boxed	1	
Infrared remote controller		Boxed	1	

# REF-SHA35IMD111TSYS User guide

## Full-featured starter kit for low voltage ceiling fan motor designs

### The board at a glance

### 1.3 Block diagram

REF-SHA35IMD111TSYS consists of a front-end AC/DC converter and a 3-phase inverter. The AC/DC part is a flyback converter using ICL8810 with power factor correction (PFC) to generate 28 V DC bus voltage. The 3-phase inverter is controlled by the iMOTION™ IMD111T-6F040 that combines a motor control engine (MCE) 2.0 and a 3-phase gate driver in one package.

The block diagram of REF-SHA35IMD111TSYS is shown in Figure 1. The pin VSP is configured to receive the IR data stream.

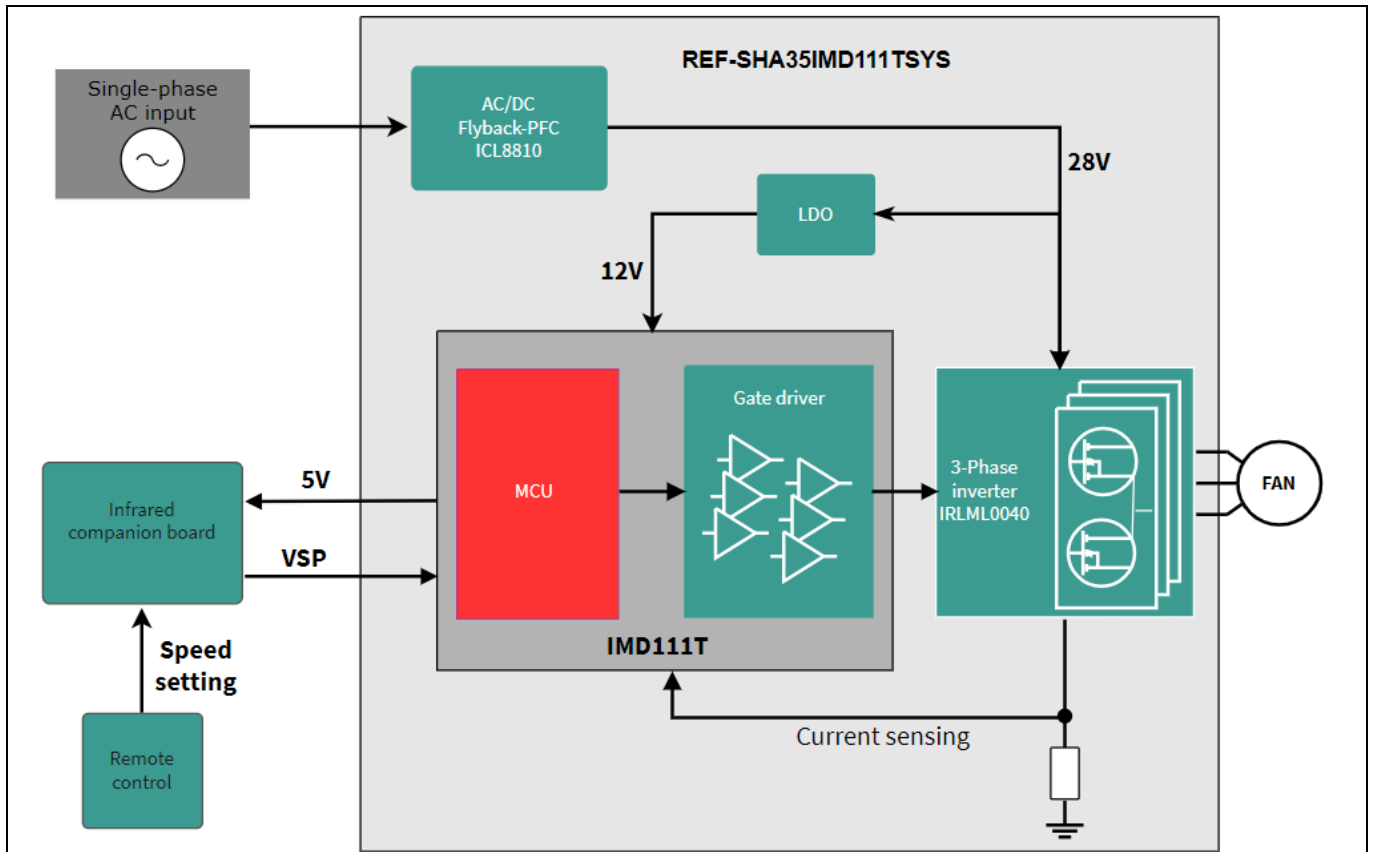

**Figure 1** Block diagram of REF-SHA35IMD111TSYS

# REF-SHA35IMD111TSYS User guide

## Full-featured starter kit for low voltage ceiling fan motor designs

### The board at a glance

The functional groups of the main board REF-SHA35IMD111TSYS and IR companion board are shown in Figure 2 to Figure 5.

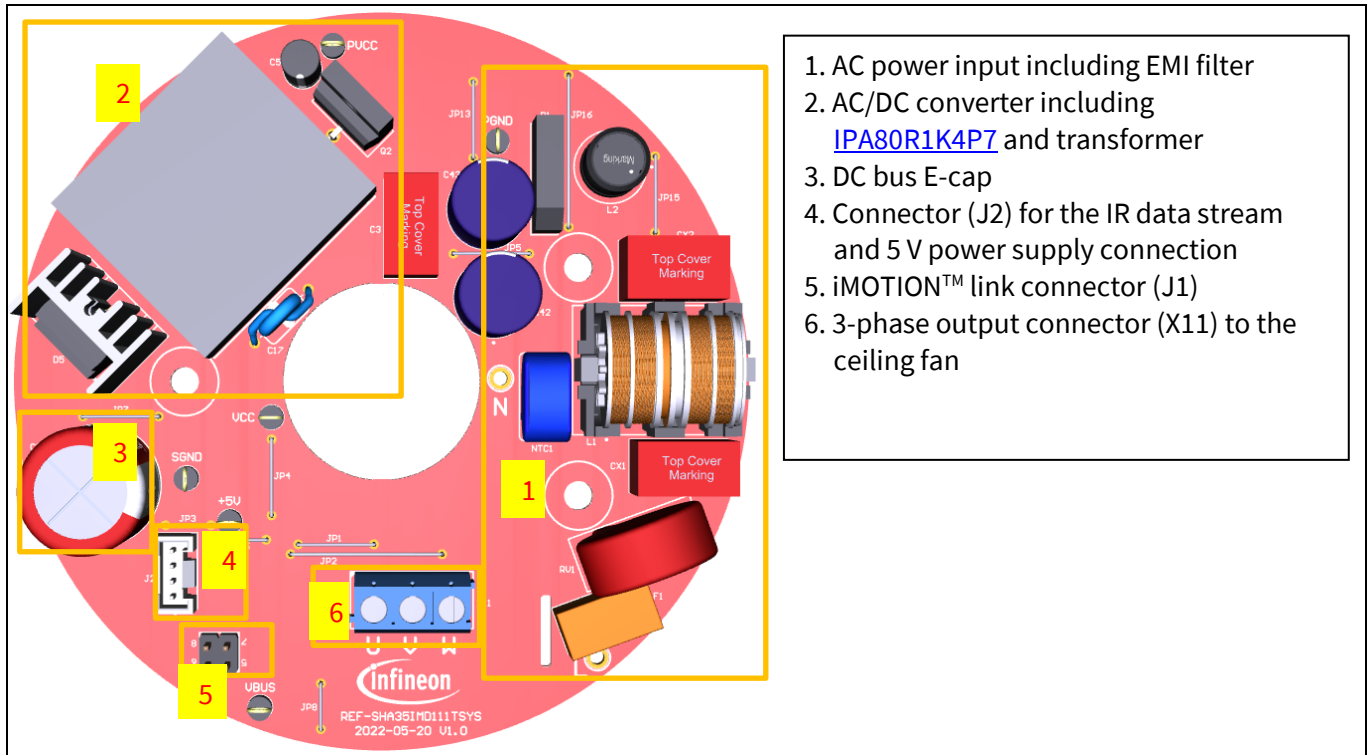

1. AC power input including EMI filter
2. AC/DC converter including [IPA80R1K4P7](#) and transformer
3. DC bus E-cap
4. Connector (J2) for the IR data stream and 5 V power supply connection
5. iMOTION™ link connector (J1)
6. 3-phase output connector (X11) to the ceiling fan

**Figure 2** REF-SHA35IMD111TSYS - top side

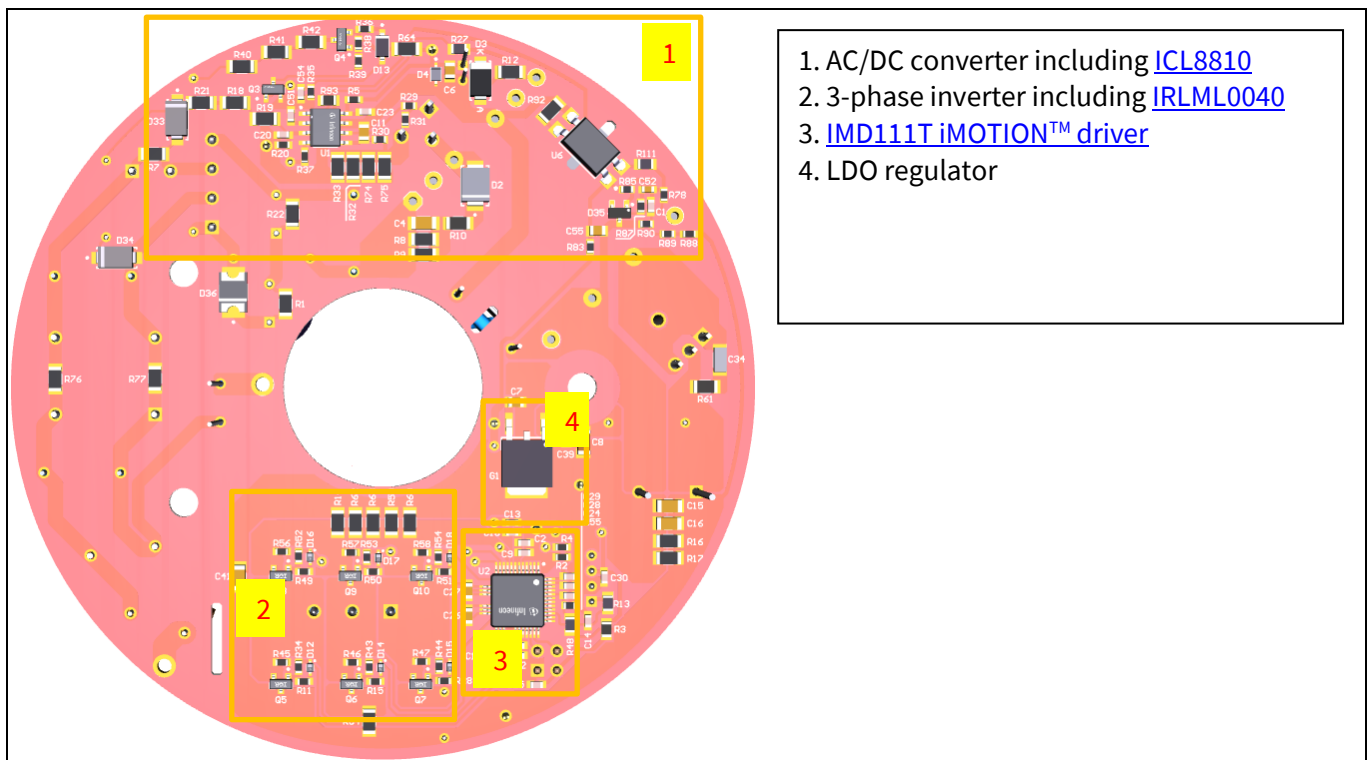

1. AC/DC converter including [ICL8810](#)
2. 3-phase inverter including [IRLML0040](#)
3. [IMD111 iMOTION™ driver](#)
4. LDO regulator

**Figure 3** REF-SHA35IMD111TSYS - bottom side



# REF-SHA35IMD111TSYS User guide

## Full-featured starter kit for low voltage ceiling fan motor designs

### The board at a glance

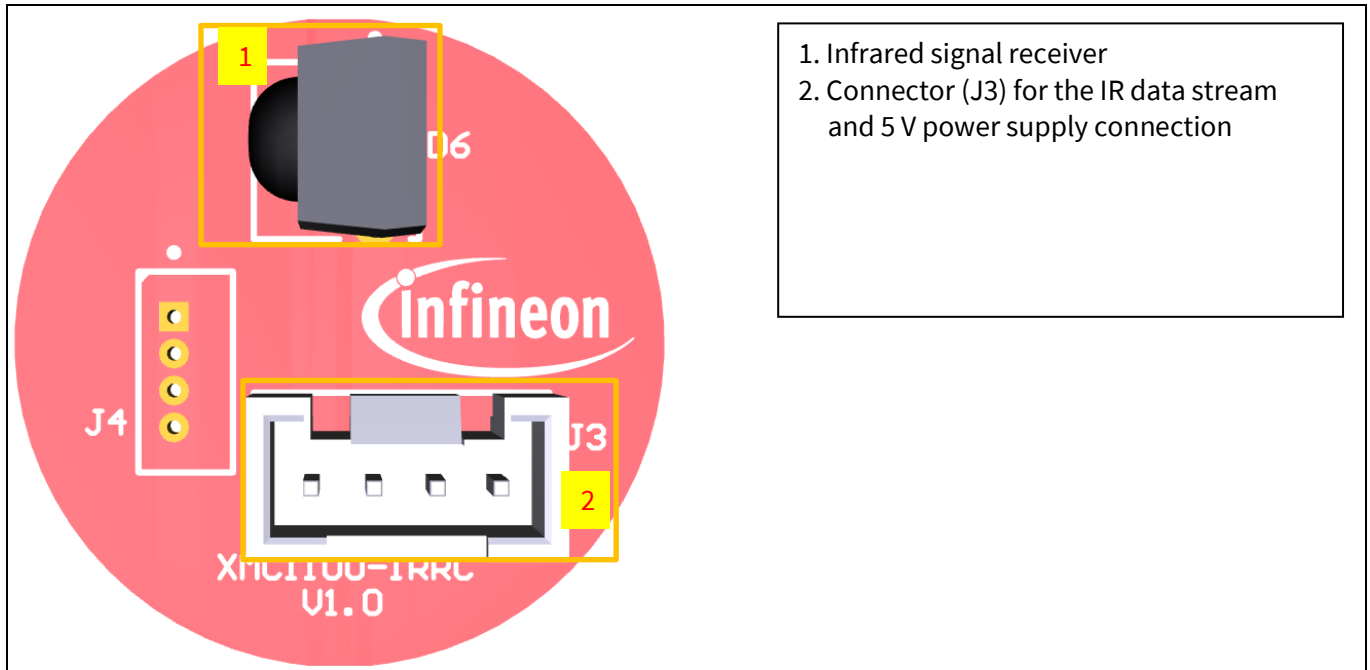

**Figure 4** IR companion board – top side

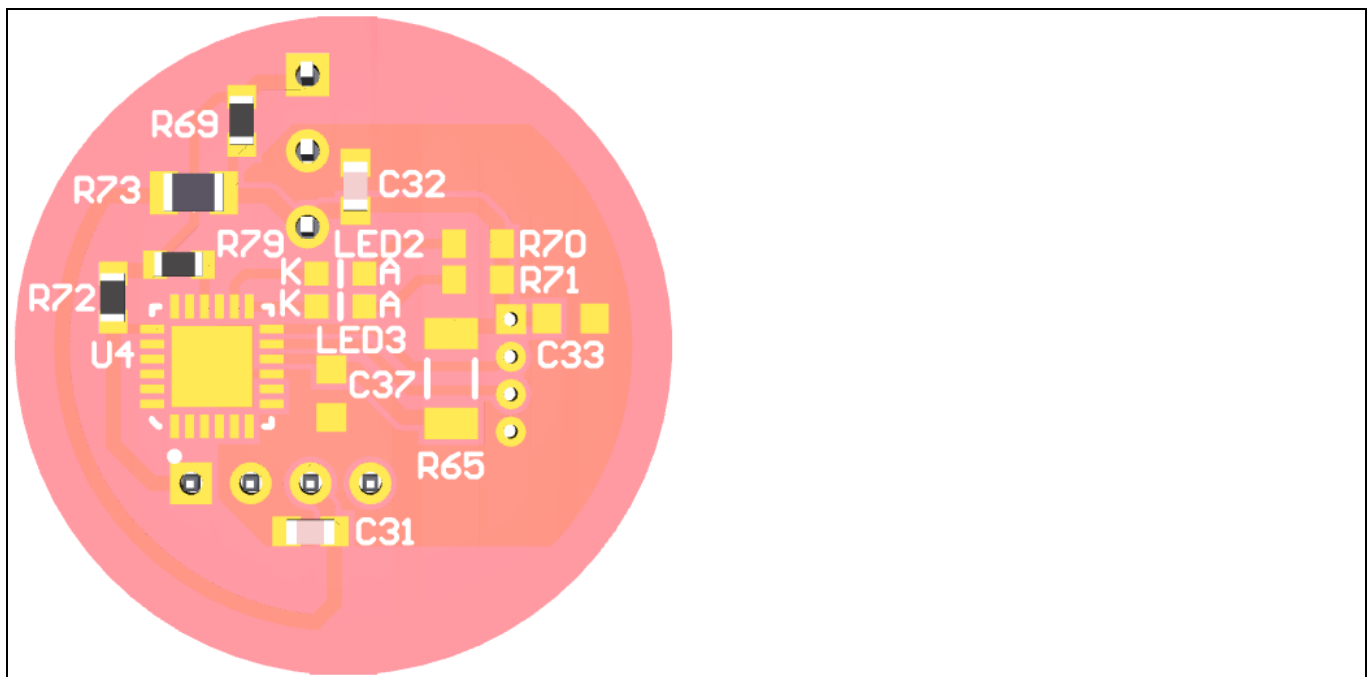

**Figure 5** IR companion board –bottom side

## The board at a glance

## 1.4 Board specification

The specifications of REF-SHA35IMD111TSYS are listed in Table 3. All the data is tested in 25°C ambient temperature.

**Table 3 board specification**

Parameter	Symbol	Conditions	Value			Unit
			Min	Nom	Max	
<b>AC input</b>						
Input voltage	$V_{ac}$	Normal work, at maximum load	90	230	300	$V_{rms}$
		Input overvoltage, at no load	300			
		Input overvoltage, at maximum load			340	
		Brown-in		85		
		Brown-out		75		
Maximum Input power	$P_{in\_max}$	$V_{ac} = 230 V_{rms}$		35		W
Power factor	PF	$V_{ac} = 230 V_{rms}$ , $P_{in} = 35 W$	0.95			
Total harmonic current distortion	iTHD				10%	
Efficiency	$\eta$		85			%
Standby power	$P_{standby}$	$V_{ac} = 230 V_{rms}$ , no load		0.94		W
<b>DC output</b>						
DC bus average voltage	$V_{bus}$	$V_{ac} = 230 V_{rms}$		28		V
<b>Current feedback</b>						
Flyback shunt resistance				0.3		$\Omega$
Inverter shunt resistance				0.25		
<b>Auxiliary power supply</b>						
Supply to the IMD111T	VCC	From low voltage dropout (LDO) device		12		V
<b>Protections</b>						
Motor over-current	$I_{trip}$	Motor overcurrent threshold set in iSD based on a tested LV ceiling fan motor		2.5		A
DC bus	$V_{bus}$	Overvoltage threshold set in iSD		31		V
		Overvoltage threshold set by ICL8810		32.5		
		Undervoltage threshold set in iSD		20		
<b>System environment</b>						
Ambient temperature	$T_a$			25		°C

**The board at a glance**

Parameter	Symbol	Conditions	Value			Unit
			Min	Nom	Max	
<b>PCB characteristics</b>						
Size		Main board	Diameter = 97, height = 25			mm
		IR Companion board	Diameter = 22, height = 5			
Material		Main board, IR companion board	FR-4, 1.6 mm thickness, 1 oz, single layer			

## 2 Schematics

The complete schematics are shown in Figure 6, Figure 7, and Figure 8.

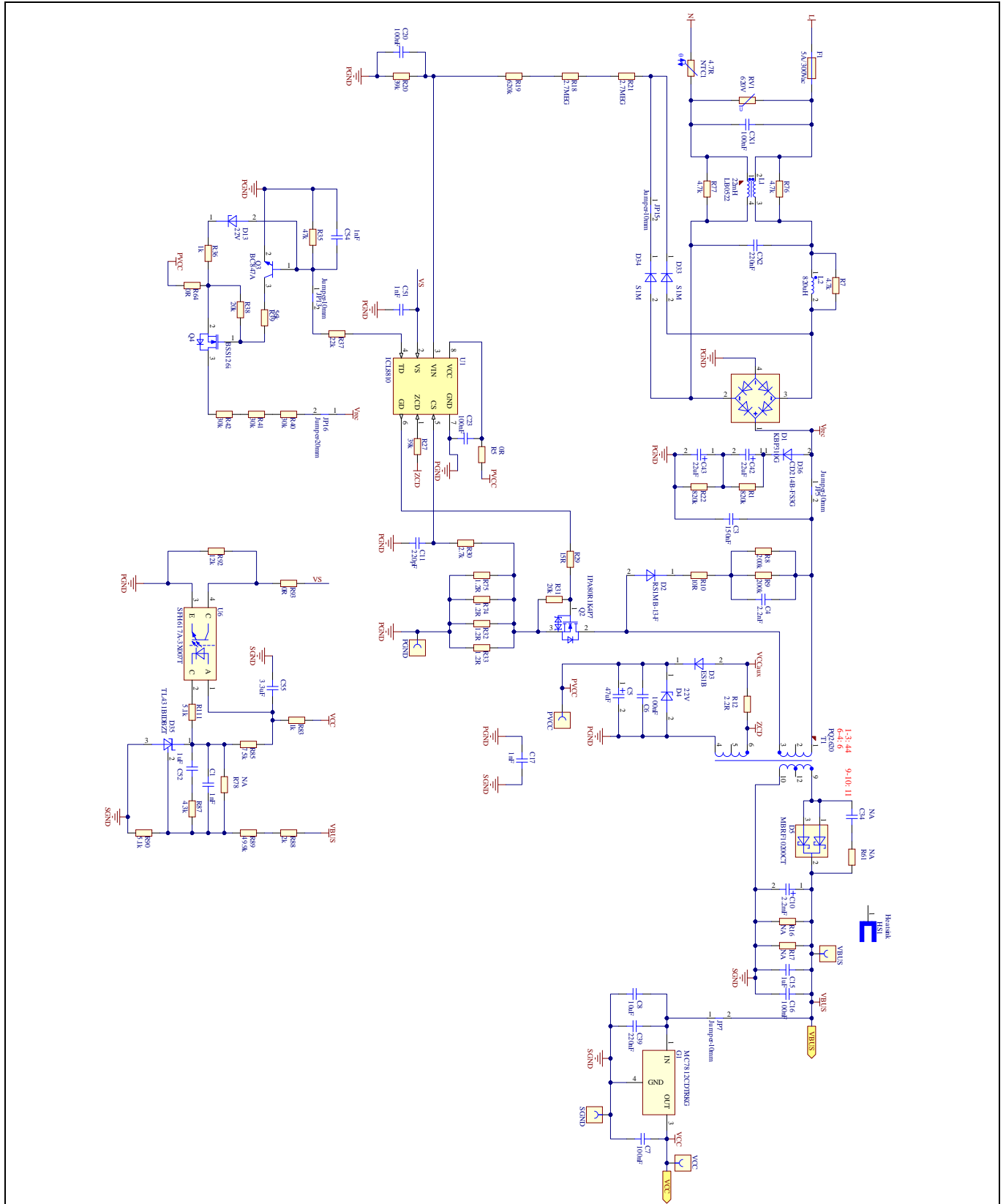

**Figure 6** Schematic of the AC/DC converter

Schematics

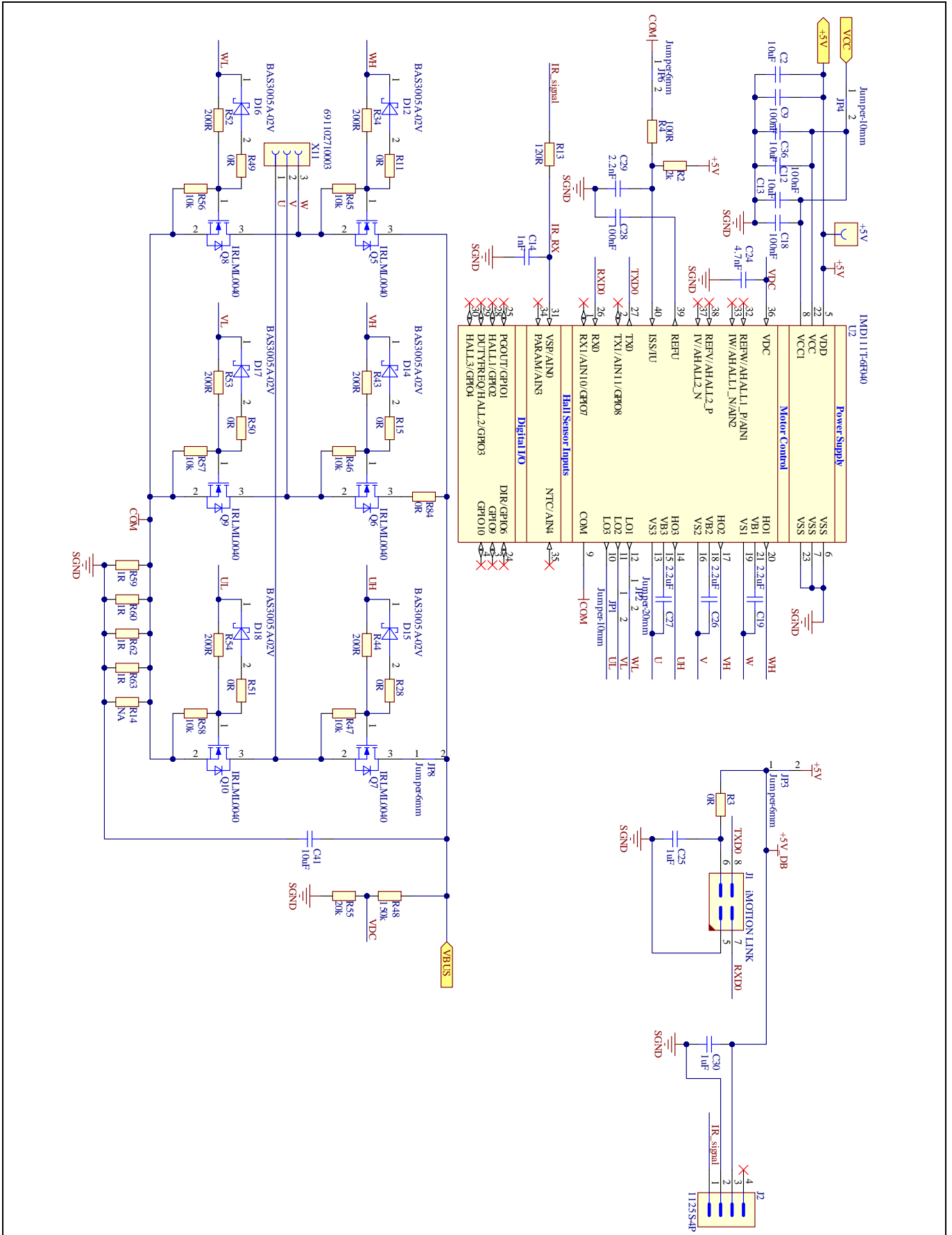

Figure 7 Schematic of the 3-phase inverter

Schematics

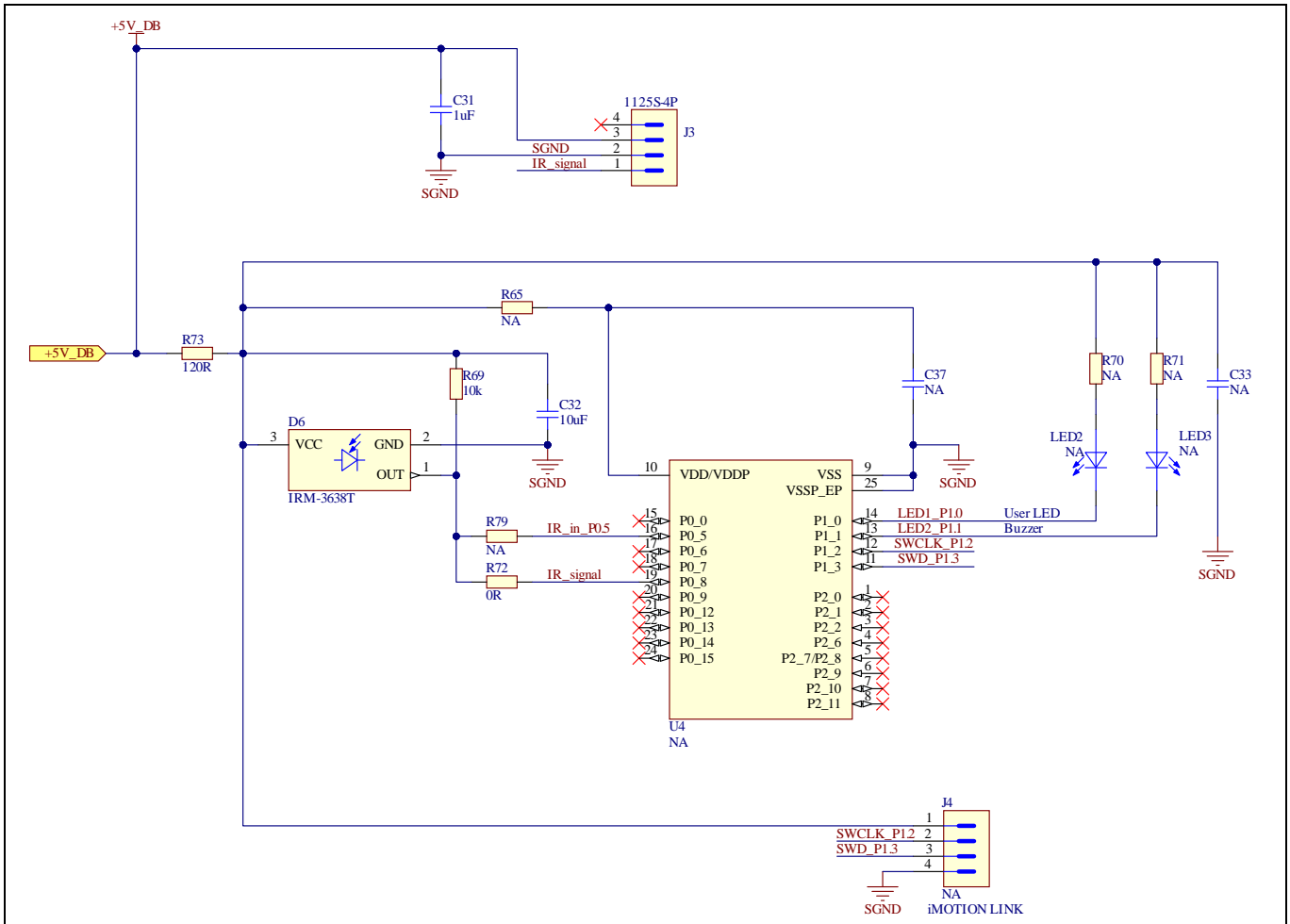

Figure 8 Schematic of the IR companion board

## Layout

### 3 Layout

Both REF-SHA35IMD111TSYS and the IR companion board are single-layer boards.

The layout of the two boards is shown in Figure 9 and Figure 10.

General layout guidelines are as follows:

- The drive loop for switches should be as small as possible, while putting the gate resistors close to the switches.
- The trace for the 28 V DC bus should be as large as possible for a smaller parasitic inductance.
- The trace linking the high-side and low-side switches of the inverter should be as large as possible to dissipate heat as well as decreasing the parasitic inductance.
- The secondary ground (SGND) should be as large as possible to dissipate heat of the LDO, shunt resistors, and IMD111T-6F040.

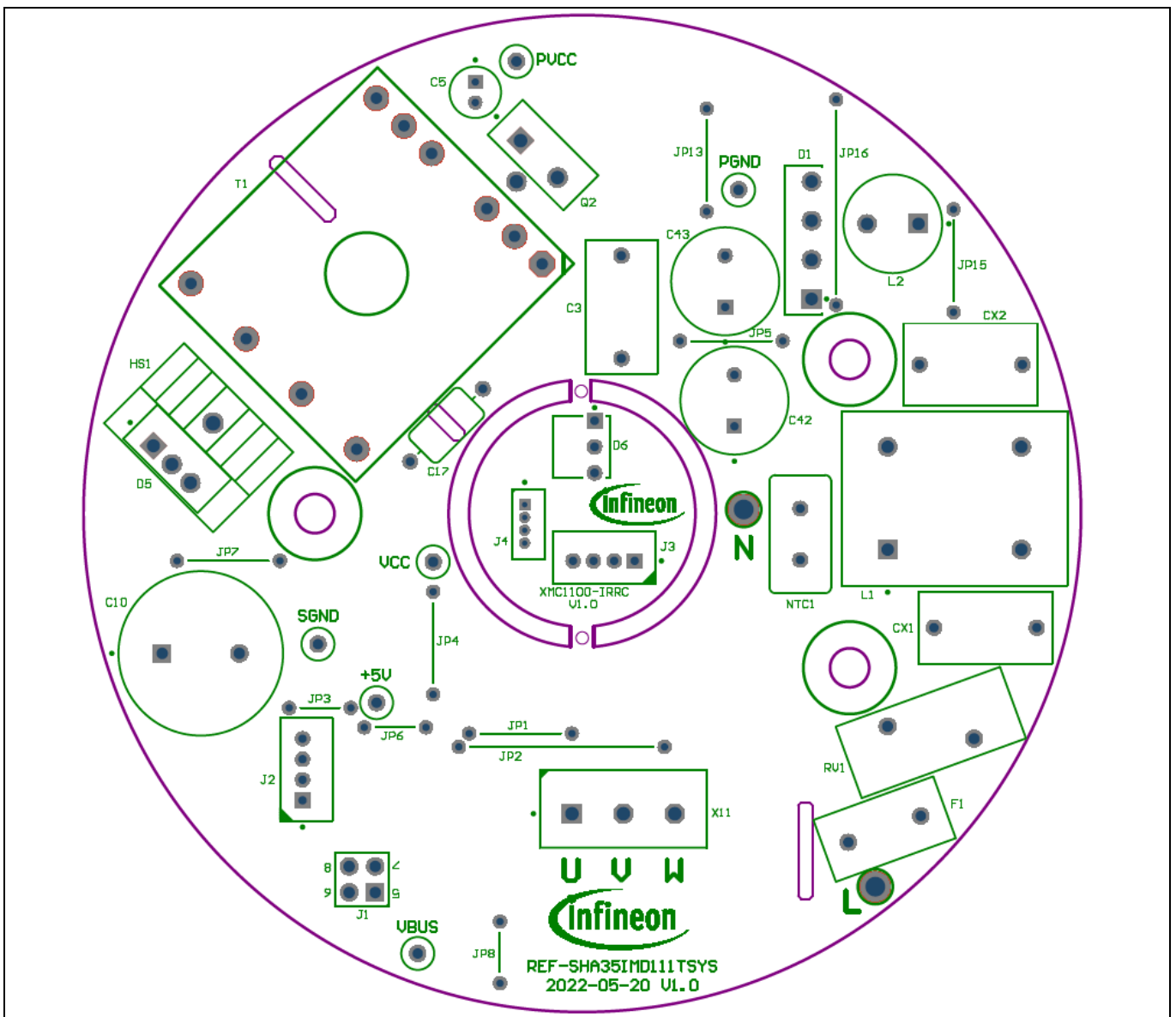

**Figure 9** Top layer of the main and companion board

Layout

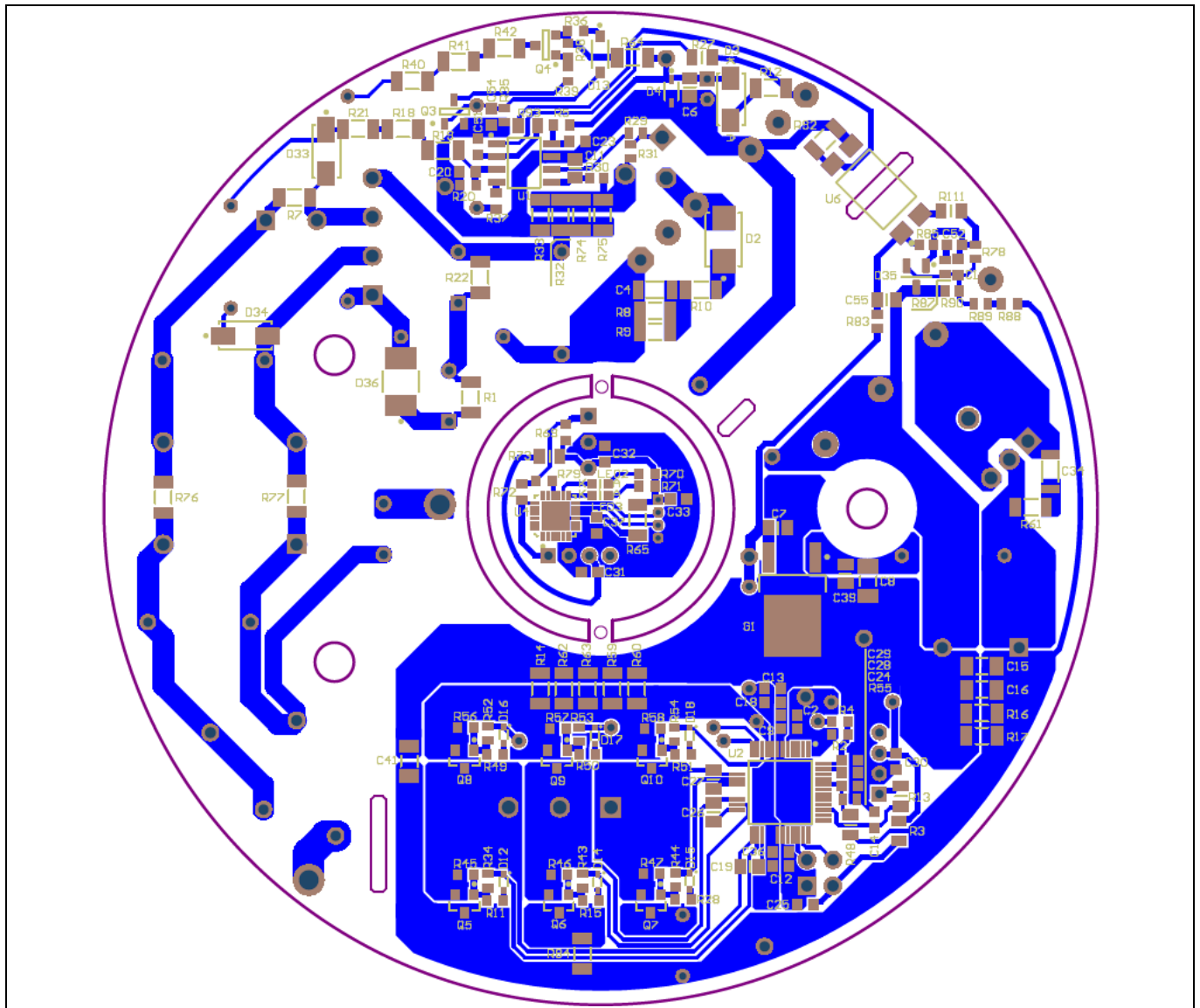

Figure 10 Bottom layer of the main and companion board



## Bill of material

## 4 Bill of material

The complete bill of material (BOM) is listed in Table 4.

**Table 4 Bill of material**

Designator	Description	Manufacturer	Manufacturer Order Number
+5V, PGND, PVCC, SGND, VBUS, VCC	Test Pin, PCB, Black, THT, 1.00mm drill	Multicomp	TEST-1(BK)
C1, C14, C51, C54	CAP / CERA / 1nF / 25V / 20% / X7R (EIA) / -55°C to 125°C / 0603(1608) / SMD / -	MuRata	GRM188R71E102MA01
C2, C13, C32, C36	CAP / CERA / 10uF / 10V / 20% / X7T (EIA) / -55°C to 125°C / 0603(1608) / SMD / -	MuRata	GRM188D71A106MA73D
C3	CAP / FILM / 150nF / 630V / 10% / MKP (Metallized Polypropylene) / -40°C to 105°C / 10.00mm C X 0.60mm W 13.00mm L X 7.00mm T X 12.50mm H / - / -	Würth Elektronik	890334023025CS
C4	CAP / CERA / 2.2nF / 630V / 10% / X7R (EIA) / -55°C to 125°C / 1206(3216) / SMD / -	MuRata	GRM31BR72J222KW01
C5	CAP / ELCO / 47uF / 35V / 20% / Aluminium electrolytic / -40°C to 105°C / 2.00mm C X 0.50mm W 5.00mm Dia X 12.50mm H / - / -	Würth Elektronik	860020572006
C6, C7	CAP / CERA / 100nF / 50V / 20% / X7R (EIA) / -55°C to 125°C / 0805(2012) / SMD / -	MuRata	GRM21BR71H104MA01
C8, C41	CAP / CERA / 10uF / 50V / 10% / X7R (EIA) / -55°C to 125°C / 1206(3216) / SMD / -	TDK Corporation	CGA5L1X7R1H106K160AC
C9, C12, C18, C20, C23, C28	CAP / CERA / 100nF / 25V / 20% / X7R (EIA) / -55°C to 125°C / 0603(1608) / SMD / -	MuRata	GRM188R71E104MA01
C10	CAP / ELCO / 2.2mF / 35V / 20% / Aluminium electrolytic / -40°C to 85°C / 7.50mm C X 0.80mm W 16.00mm Dia X 26.50mm H / - / -	Würth Elektronik	860010580021
C11	CAP / CERA / 220pF / 50V / 20% / X7R (EIA) / -55°C to 125°C / 0805(2012) / SMD / -	MuRata	GRM216R71H221MA01
C15	CAP / CERA / 1uF / 50V / 20% / X7R (EIA) / -55°C to 125°C / 1206(3216) / SMD / -	MuRata	GRM31CR71H105MA61
C16	CAP / CERA / 100nF / 50V / 20% / X7R (EIA) / -55°C to 125°C / 1206(3216) / SMD / -	MuRata	GCM31MR71H104MA37
C17	CAP / CERA / 1nF / 20% / E (JIS) / -40°C to 125°C / 10.00mm C X 0.60mm W 7.00mm L X 4.00mm T X 10.00mm H / THT / -	MuRata	DE1E3RA102MA4BP01F
C19, C26, C27	CAP / CERA / 2.2uF / 25V / 20% / X7R (EIA) / -55°C to 125°C / 0805(2012) / SMD / -	MuRata	GCM21BR71E225MA73
C24	CAP / CERA / 4.7nF / 50V / 20% / X7R (EIA) / -55°C to 125°C / 0603(1608) / SMD / -	MuRata	GRM188R71H472MA01
C25, C30, C31, C52	CAP / CERA / 1uF / 25V / 20% / X7R (EIA) / -55°C to 125°C / 0603(1608) / SMD / -	MuRata	GRM188R71E105MA12

## Bill of material

C29	CAP / CERA / 2.2nF / 25V / 20% / X7R (EIA) / -55°C to 125°C / 0603(1608) / SMD / -	MuRata	GRM188R71E222MA01
C39	CAP / CERA / 220nF / 50V / 20% / X7R (EIA) / -55°C to 125°C / 0805(2012) / SMD / -	MuRata	GRM21BR71H224MA01
C42, C43	CAP / ELCO / 22uF / 350V / 20% / Aluminium electrolytic / -40°C to 105°C / 5.00mm C X 0.60mm W 10.50mm Dia X 21.50mm H / - / -	Nichicon	UCY2V220MPD9
C55	CAP / CERA / 3.3uF / 25V / 20% / X7R (EIA) / -55°C to 125°C / 0805(2012) / SMD / -	MuRata	GRM21BR71E335MA73
CX1	CAP / FILM / 100nF / 630V / 10% / - / -40°C to 105°C / 10.00mm C X 0.60mm W 13.00mm L X 7.00mm T X 13.50mm H / THT / -	Würth Elektronik	890334023023CS
CX2	CAP / FILM / 220nF / 630V / 10% / MKP (Metallized Polypropylene) / -40°C to 105°C / 10.00mm C X 0.60mm W 13.00mm L X 8.00mm T X 14.50mm H / - / -	Würth Elektronik	890334023028CS
D1	3.0A, Glass Passivated Bridge Rectifier	Diodes Incorporated	KBP310G
D2	Fast Recovery Rectifier, 1A	Diodes Incorporated	RS1MB-13-F
D3	Surface Mount Ultrafast Plastic Rectifier, Temp Range (-55 to 150°C)	Taiwan semiconductor	ES1BHE3_A/H
D4	Silicon Epitaxial Planar Zener Diode, Vz 22.470V Max, Iz 5mA	ROHM Semiconductors	UDZVTE-1722B
D5	Schottky Barrier Rectifier, 200V	Littelfuse	MBRF10200CT
D6	Infrared Receiver Module Remote Receiver Sensor	Everlight	IRM-3638T
D12, D14, D15, D16, D17, D18	Low VF Schottky Diode	Infineon Technologies	BAS3005A-02V
D13	Zener Diode 22V 5% 500 mW	ON Semiconductor	MMSZ22T1G
D33, D34	General Purpose Rectifier	ON Semiconductor	S1M
D35	Precision Programmable Reference	Texas Instruments	TL431BIDBZT
D36	Fast Response Rectifier Chip Diode	Bourns	CD214B-FS3G
F1	RES / STD / - / - / - / - / -40°C to 125°C / 7.50mm C X 0.60mm W 12.40mm L X 6.40mm T X 9.80mm H / - / -	Littelfuse	80715000000
G1	Voltage Regulators	ON Semiconductor	MC7812CDTRKG
HS1	Heatsink 11x15mm for TO220AB	-	Heatsink 11x15mm for TO220AB
J1	WR-PHD Dual Pin Header	Würth Elektronik	61300421121_Custom
J2, J3	DIP Grove Female Header-White;4P-2.0, Straight	Shenzhen NS-Tech Co. Ltd	1125S-4P

## Bill of material

JP1, JP4, JP5, JP7, JP13, JP15	10 MM General Jumper	-	Jumper-10mm
JP2, JP16	20 MM General Jumper	-	Jumper-20mm
JP3, JP6, JP8	6MM General Jumper	-	Jumper-6mm
L1	IND / STD / 22mH / 500mA / - / -25 癩 to 105 癩 / 1.5R / Radial / Inductor, THT; 13.00 mm pitch, 4 pin, 17 mm L X 22 mm W X 23.50 mm H body / - / -	QYET	LB0522
L2	IND / STD / 820uH / 700mA / 10% / -40°C to 125°C / 1.2R / THT, 5mm pitch, 9.5 diameter / Inductor, Radial;5.00mm C X 0.65mm W 9.50mm Dia X 13.50mm H / THT / -	Wurth Elektronik	7447452821
NTC1	RES / NTC / 4.7R / 2.1W / - / - / -55°C to 170°C / 5.00mm C X 0.60mm W 11.50mm L X 6.00mm T X 16.00mm H / THT / -	TDK Corporation	B57236S0479M000
Q2	IPA80R1K4P7-bend drain lead	Infineon Technologies	IPA80R1K4P7-bend drain lead
Q3	NPN Silicon AF Transistor	Infineon Technologies	BC847A
Q4	SIPMOS Small-Signal-Transistor, VDS 600V, IDSS min 0.007A	Infineon Technologies	BSS126i
Q5, Q6, Q7, Q8, Q9, Q10	HEXFET Power MOSFET, DC Motor Drive Applications	Infineon Technologies	IRLML0040
R1, R22	RES / STD / 820k / 250mW / 1% / 100ppm/K / -55°C to 155°C / 1206(3216) / SMD / -	Vishay	CRCW1206820KFK
R2, R88	RES / STD / 2k / 100mW / 1% / 100ppm/K / -55°C to 155°C / 0603(1608) / SMD / -	Yageo	AC0603FR-072KL
R3, R93	RES / STD / 0R / 125mW / 0R / 0ppm/K / -55°C to 155°C / 0805(2012) / SMD / -	Yageo	RC0805JR-070RL
R4	RES / STD / 100R / 100mW / 1% / 100ppm/K / -55°C to 155°C / 0603(1608) / SMD / -	Yageo	RC0603FR-07100RL
R5, R11, R15, R28, R49, R50, R51, R72	RES / STD / 0R / 100mW / 0R / 0ppm/K / -55°C to 155°C / 0603(1608) / SMD / -	Yageo	RC0603JR-070RL
R7, R76, R77	RES / STD / 4.7k / 250mW / 1% / 100ppm/K / -55°C to 155°C / 1206(3216) / SMD / -, RES / STD / 4.7k / 250mW / 1% / 100ppm/K / -55°C to 155°C / 1206 / SMD / -	Vishay	CRCW12064K70FK
R8, R9	RES / STD / 200k / 250mW / 1% / 100ppm/K / -55°C to 155°C / 1206 / SMD / -	Vishay	CRCW1206200KFK
R10	RES / STD / 10R / 250mW / 1% / 200ppm/K / -55°C to 155°C / 1206 / SMD / -	Yageo	RC1206FR-0710RL
R12	RES / STD / 2.2R / 250mW / 1% / 100ppm/K / -55°C to 155°C / 1206 / SMD / -	Vishay	CRCW12062R20FK

## Bill of material

R13, R73	RES / STD / 120R / 125mW / 1% / 100ppm/K / -55°C to 155°C / 0805(2012) / SMD / -	Vishay	CRCW0805120RFK
R18, R21	RES / STD / 2.7MEG / 250mW / 1% / 100ppm/K / -55°C to 155°C / 1206 / SMD / -	Vishay	CRCW12062M70FK
R19	RES / STD / 620k / 250mW / 1% / 100ppm/K / -55°C to 155°C / 1206(3216) / SMD / -	Vishay	CRCW1206620KFK
R20	RES / STD / 39k / 100mW / 1% / 100ppm/K / -55°C to 155°C / 0603(1608) / SMD / -	Yageo	RC0603FR-0739KL
R27	RES / STD / 39k / 125mW / 1% / 100ppm/K / -55°C to 155°C / 0805 / SMD / -	Vishay	CRCW080539K0FK
R29	RES / STD / 15R / 100mW / 1% / 100ppm/K / -55°C to 155°C / 0603 / SMD / -	Vishay	CRCW060315R0FK
R30	RES / STD / 2.7k / 100mW / 1% / 100ppm/K / -55°C to 155°C / 0603(1608) / SMD / -	Vishay	CRCW06032K70FK
R31, R38, R55	RES / STD / 20k / 100mW / 1% / 100ppm/K / -55°C to 155°C / 0603 / SMD / -, RES / STD / 20k / 100mW / 1% / 100ppm/K / -55°C to 155°C / 0603(1608) / SMD / -	Vishay	CRCW060320K0FK
R32, R33, R74, R75	RES / STD / 1.2R / 250mW / 1% / 100ppm/K / -55°C to 155°C / 1206(3216) / SMD / -	Vishay	CRCW12061R20FK
R34, R43, R44, R52, R53, R54	RES / STD / 200R / 100mW / 1% / 100ppm/K / -55°C to 155°C / 0603(1608) / SMD / -	Vishay	CRCW0603200RFK
R35	RES / STD / 47k / 100mW / 1% / 100ppm/K / -55°C to 155°C / 0603 / SMD / -	Vishay	CRCW060347K0FK
R36	RES / STD / 1k / 100mW / 1% / 100ppm/K / -55°C to 155°C / 0603 / SMD / -	Yageo	RC0603FR-071KL
R37	RES / STD / 22k / 100mW / 1% / 100ppm/K / -55°C to 155°C / 0603(1608) / SMD / -	Yageo	RC0603FR-0722KL
R39	RES / STD / 56k / 100mW / 1% / 100ppm/K / -55°C to 155°C / 0603 / SMD / -	Vishay	CRCW060356K0FK
R40, R41, R42	RES / STD / 30k / 250mW / 1% / 100ppm/K / -55°C to 155°C / 1206(3216) / SMD / -	Vishay	CRCW120630K0FK
R45, R46, R47, R56, R57, R58, R69	RES / STD / 10k / 100mW / 1% / 100ppm/K / -55°C to 155°C / 0603 / SMD / -, RES / STD / 10k / 100mW / 1% / 100ppm/K / -55°C to 155°C / 0603(1608) / SMD / -	Yageo	RC0603FR-0710KL
R48	RES / STD / 150k / 125mW / 1% / 100ppm/K / -55°C to 155°C / 0805(2012) / SMD / -	Vishay	CRCW0805150KFK
R59, R60, R62, R63	RES / STD / 1R / 250mW / 1% / 100ppm/K / -55°C to 155°C / 1206(3216) / SMD / -	Vishay	CRCW12061R00FKEA
R64, R84	RES / STD / 0R / - / 0% / - / -55°C to 155°C / 1206(3216) / SMD / -	Vishay	CRCW12060000Z0EA
R83	RES / STD / 1k / 100mW / 1% / 100ppm/K / -55°C to 155°C / 0603(1608) / SMD / -	Vishay	CRCW06031K00FK

## Bill of material

R85	RES / STD / 7.5k / 100mW / 1% / 100ppm/K / -55°C to 155°C / 0603 / SMD / -	Vishay	CRCW06037K50FK
R87	RES / STD / 4.3k / 100mW / 1% / 100ppm/K / -55°C to 155°C / 0603(1608) / SMD / -	Vishay	CRCW06034K30FK
R89	RES / STD / 49.9k / 100mW / 1% / 100ppm/K / -55°C to 155°C / 0603 / SMD / -	Vishay	CRCW060349K9FK
R90	RES / STD / 5.1k / 100mW / 1% / 100ppm/K / -55°C to 155°C / 0603(1608) / SMD / -	Vishay	CRCW06035K10FK
R92	RES / STD / 12k / 250mW / 1% / 100ppm/K / -55°C to 155°C / 1206 / SMD / -	Vishay	CRCW120612K0FK
R111	RES / STD / 5.1k / 125mW / 1% / 100ppm/K / -55°C to 155°C / 0805 / SMD / -	Vishay	CRCW08055K10FK
RV1	RES / VDR / 620V / - / - / - / -55°C to 85°C / Varistor, THT, 7.50 mm pitch, 2 pin, 17.00 mm L X 7.30 mm W X 20.50 mm body / - / -	Littelfuse	V385LA20AP
T1	PQ2620, 11 pins		
U1	ICL88xx family of single stage flyback (SSR) controllers	Infineon Technologies	ICL8810
U2	Motor controller with integrated high-voltage gate driver	Infineon Technologies	IMD111T-6F040
U4	XMC1000 Industrial Microcontrollers ARM® Cortex™-M0 32-bit processor core	Infineon Technologies	XMC1100-Q024F0064
U6	Optocoupler, Phototransistor Output, High Reliability, 5300 VRMS, 110 °C Rated	Vishay	SFH617A-3X007T
X11	Terminal Block, 3Pins, 5.00mm Pitch, Board to Cable	Wurth Elektronik	691102710003

## Connectors

## 5 Connectors

### 5.1 Main board connectors

**Table 5 AC input pads**

PIN	Label	Function
	L	AC line input
	N	AC neutral input

**Table 6 J1- iMOTION™ link connector**

PIN	Label	Function
5	GND	Ground
6	+5 V	On-board 5 V supply
7	RXD0	Serial communication
8	TXD0	Serial communication

**Table 7 J2 – Connector to the IR companion board**

PIN	Label	Function
1	IR command	IR command from companion board
2	GND	Ground
3	+5 V	On-board 5 V supply
4	Reserved	Reserved

### 5.2 IR companion board connectors

**Table 8 J3 – Connector to the main board**

PIN	Label	Function
1	IR command	IR command signal to main board
2	GND	Ground
3	+5 V	On-board 5 V supply
4	Reserved	Reserved

## Design description

## 6 Design description

### 6.1 AC/DC converter

*Note:* The detailed design process of the AC/DC converter with ICL8810 is not illustrated in this document. Users can read the references [1][2][3][4] for more design tips.

#### 6.1.1 EMI filter and surge protection

The electromagnetic interference (EMI) filter and surge protection circuit are shown in Figure 11.

The EMI stage consists of two X capacitors CX1 and CX2, one common-mode (CM) choke L1, and one differential mode (DM) choke L2.

*Note:* The EMI performance is not tested on this board. The components can be customized to pass any specific EMI criteria.

It is challenging for a single-stage PFC converter to pass the 4 kV L-N surge test due to no electrolytic capacitors (E-cap) behind the bridge [4].

The surge protection circuit includes a metal oxide varistor (MOV) RV1 in front and an additional surge absorber (comprising of D36, C42, and C43) just behind the bridge. The two E-caps C42 and C43 work as a tank to absorb the surge energy without impacting the power factor, as the D36 blocks the E-caps from discharging to the AC input current path.

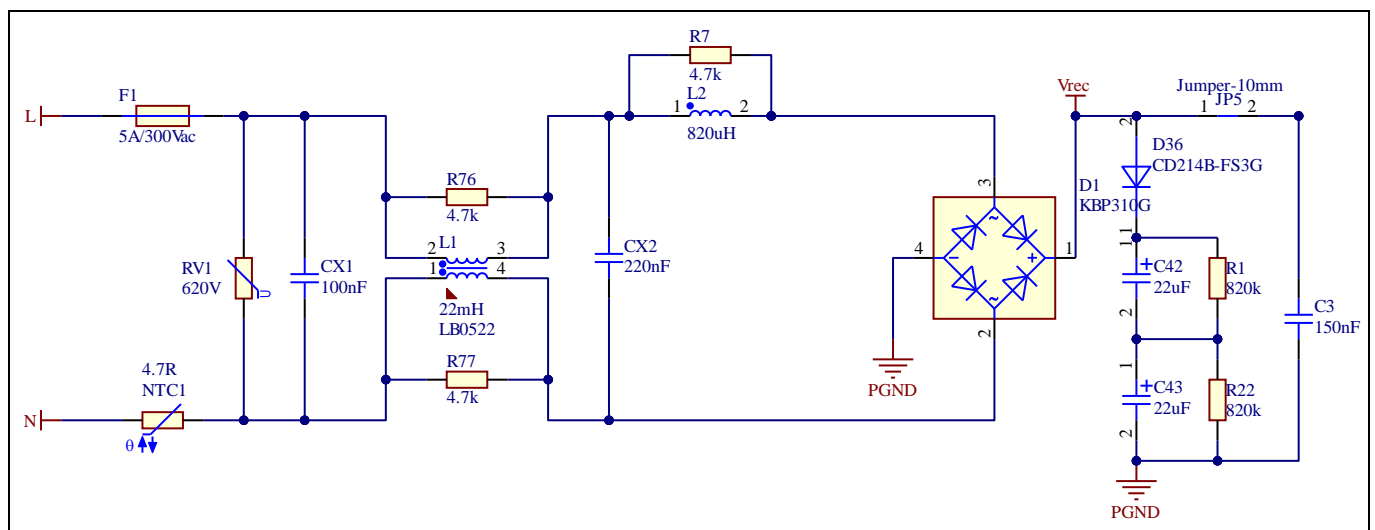

**Figure 11** EMI filter and surge protection

#### 6.1.2 Transformer design

The transformer has been designed as per the following guidelines [2]:

- Assuming 80% efficiency at 90 V<sub>rms</sub> input with maximum load, the transformer should be capable of transferring 38 W power at 90 V<sub>rms</sub>. The magnetic core PQ2620 is a good choice for balancing the thermal performance and cost.

# REF-SHA35IMD111TSYS User guide

## Full-featured starter kit for low voltage ceiling fan motor designs

### Design description

- Setting the turns ratio to 4:1 so that at 300 V<sub>rms</sub> input the primary MOSFET drain-source voltage stress (V<sub>ds</sub>) is less than 650 V including 20% spike. To pass the 4 kV L-N surge test, it is not recommended to set the turns ratio at 5:1 or above.
- Trimming the primary inductance to 430 μH, as a result of which the switching frequency is 65 kHz at 90 V<sub>rms</sub> and will go up to 95 kHz at 230 V<sub>rms</sub>. The maximum magnetic flux density (B<sub>max</sub>) is less than 0.25 T.

The transformer datasheet is detailed in Chapter 9.

### 6.1.3 ICL8810 configuration

ICL8810 is a single-stage flyback controller for constant voltage output including PFC function. The peripheral circuit of ICL8810 is shown in Figure 12.

The component values are selected as following [1][2][3]:

- R21, R18, R19, and R20 set the AC input brown-in and overvoltage protection (OVP) threshold. With the resistor values setting in Figure 22, the brown-in threshold is 85 V<sub>rms</sub>, while the OVP threshold is in the range of 300 V<sub>rms</sub> to 340 V<sub>rms</sub> for different load conditions.
- R27 affects the on-time of ICL8810 and the valley number at which the converter turns on the main MOSFET. 39 kΩ is the optimized value for the best trade-off between THD, power limitation, and performance.
- R30 is calculated for the output OVP threshold based on the selection of R27. Here, R30 is selected with 2.2 kΩ to set the output OVP threshold at 32.5 V.
- The shunt resistor is set to 0.3 Ω above which the DC bus will drop to 90 V<sub>rms</sub> input with maximum load. The shunt consists of four 1.2 Ω/0.25 W surface-mounted-device (SMD) resistors in parallel to dissipate the 0.17 W power loss and endure the large current in the 4 kV surge test.
- The maximum total power loss of the P7 MOSFET is around 1 W. Users must trim the gate resistor R29 to meet the EMI requirements.

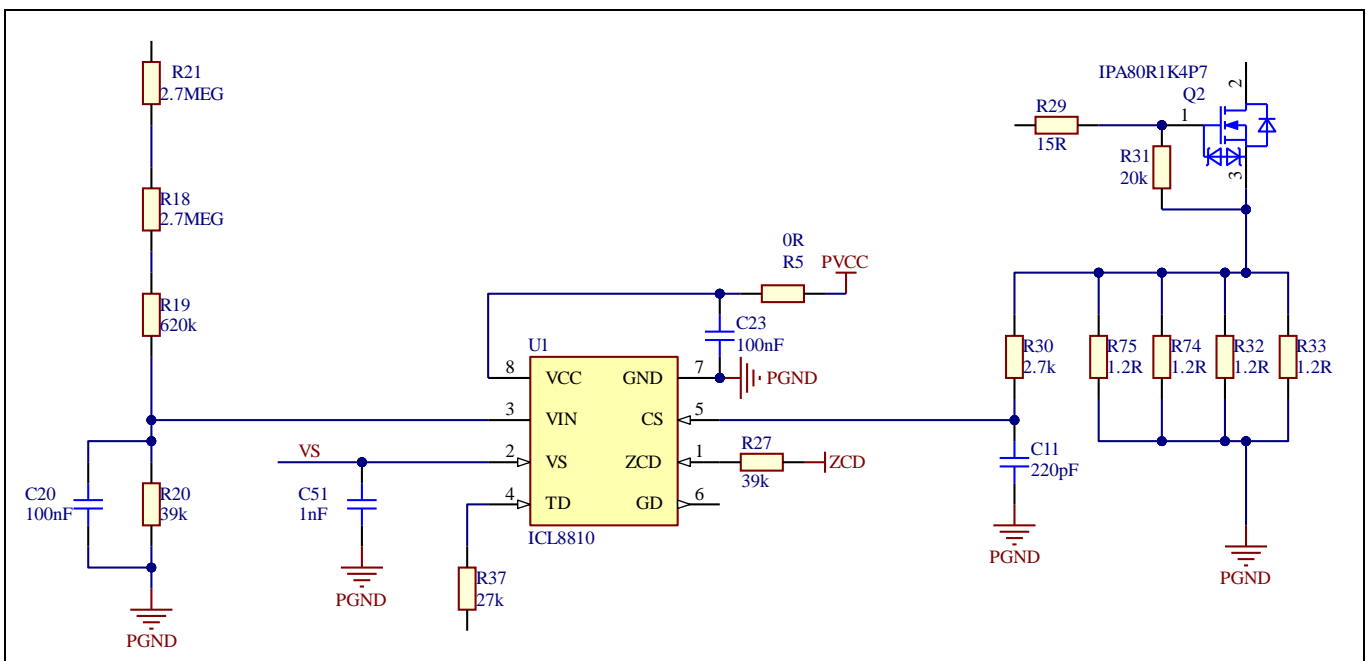

Figure 12 Peripheral circuit of ICL8810



# REF-SHA35IMD111TSYS User guide

## Full-featured starter kit for low voltage ceiling fan motor designs

### Design description

#### 6.1.4 Power supply to ICL8810

The power supply to ICL8810 (PVCC) is from an auxiliary winding of the transformer with an extra active startup circuit [1][2][3] as shown in Figure 13.

As a depletion mode MOSFET, Q4 BSS126i is normally ON when its gate-source is zero. At the beginning, the PVCC is charged through R40, R41, R42 and Q4 from the AC rectified voltage. After the PVCC reaches the turn-on threshold of ICL8810, the main MOSFET Q2 switches ON, and the auxiliary winding takes over the PVCC supply. During normal work, the TD pin of ICL8810 stays high to turn on the Q3, so the gate-source voltage of Q4 is negative-biased. As a result, the Q4 turns OFF to disconnect the PVCC from the AC rectified voltage.

It is recommended that the TD pin be pulled down by a 27 kΩ to 68 kΩ resistor. Here the R37, R35, and Q3 form an equivalent 33 kΩ pull-down resistor for better THD performance.

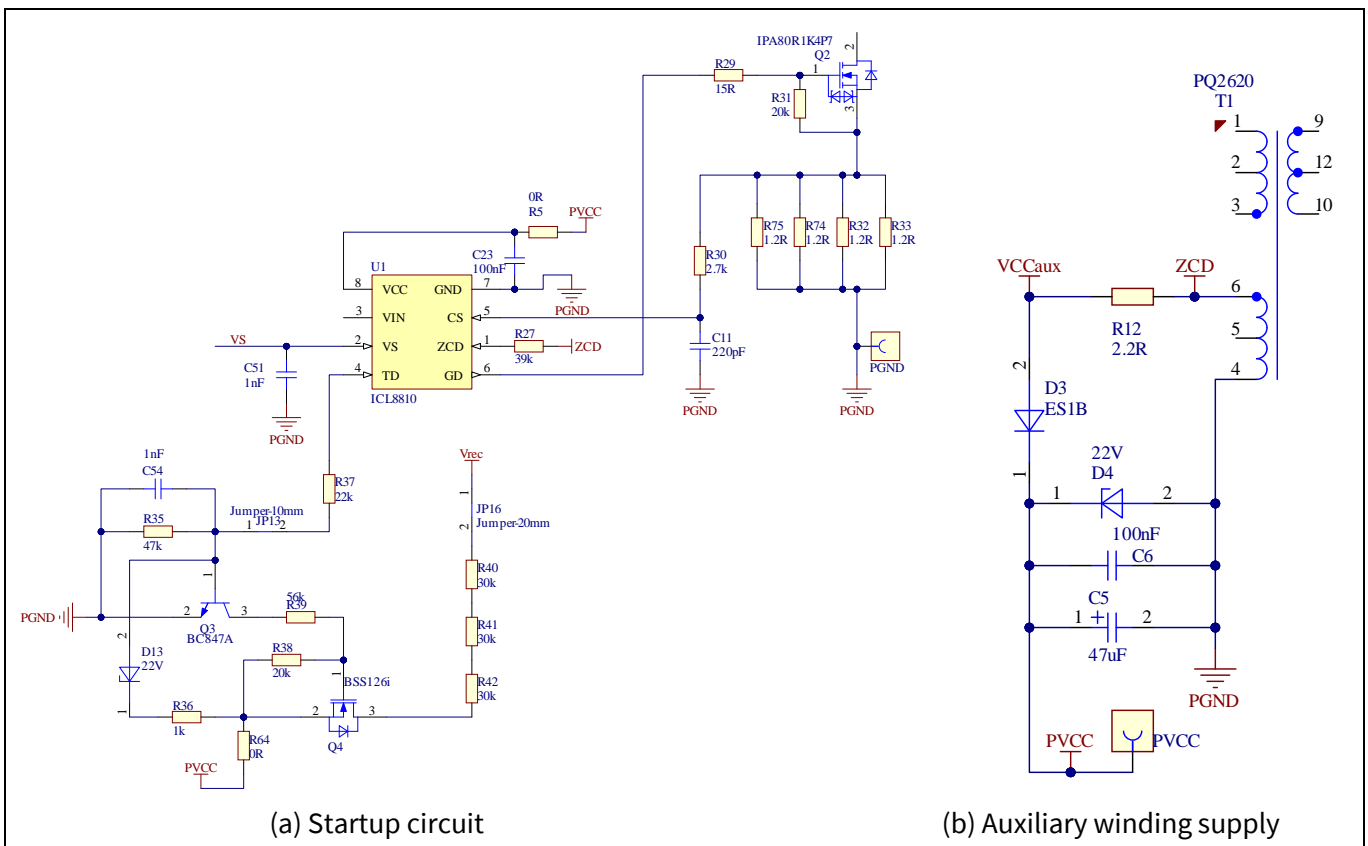

**Figure 13 Power supply to ICL8810**

#### 6.1.5 Feedback loop

The main output voltage is set to 28 V, to accommodate a variety of low voltage ceiling fan motors.

A type II feedback compensation network is used, as shown in Figure 14. The bandwidth has been set to 3 Hz to achieve high PFC and low THD values.

## Design description

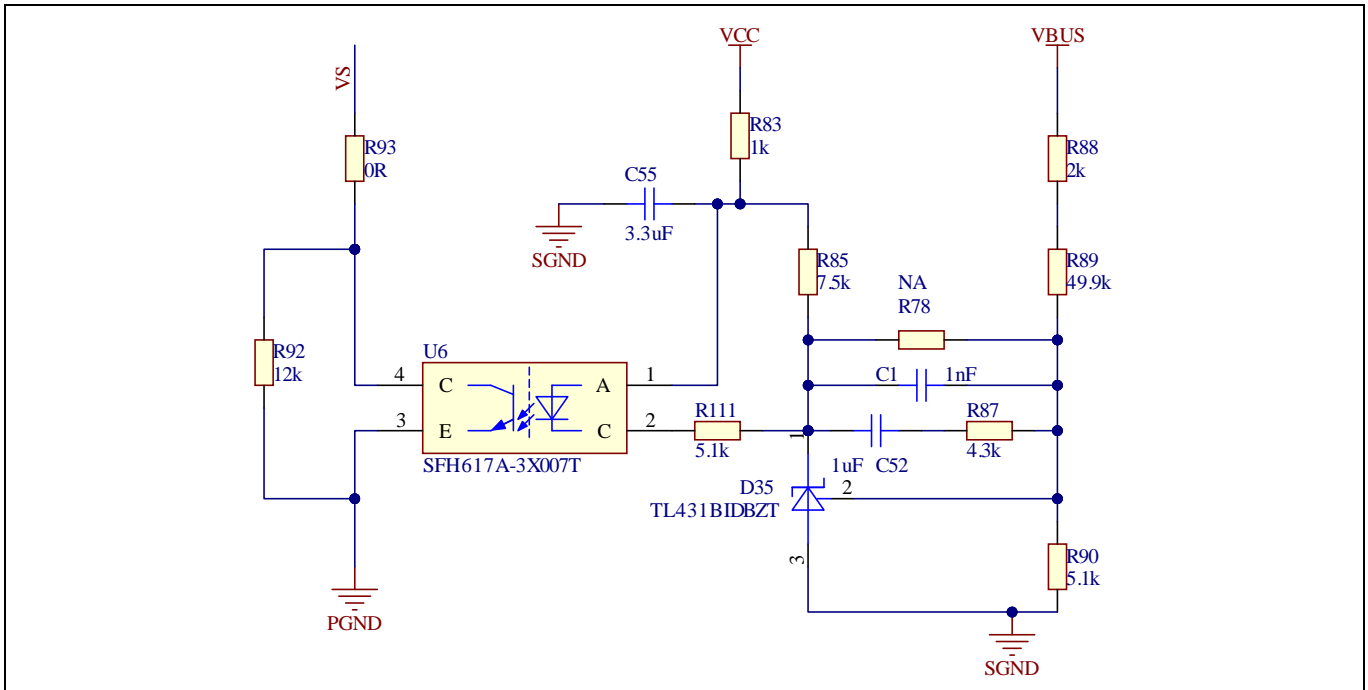

Figure 14 The feedback loop setup

## 6.2 3-phase inverter and control

### 6.2.1 3-phase inverter

The 3-phase inverter is shown in Figure 15.

Since the IRLML0040 is a logic MOSFET with smaller gate-source turn-on threshold ( $V_{gs(th)}$ ) than the power MOSFET, its drive circuit should be well designed. The key guidelines to follow are [7][8]:

- Each MOSFET should have a 10 k $\Omega$  pull-down resistor at the gate-source to avoid any gate-source voltage ( $V_{gs}$ ) bumping during the bus voltage rising period.
- The turn-on resistor ( $R_{gon}$ ) should be as large and the turn-off resistor ( $R_{goff}$ ) as small as possible to avoid the  $V_{gs}$  voltage bumping due to Miller effect. In this design, the  $R_{gon}$  selected is 200  $\Omega$  whereas the  $R_{goff}$  is 0  $\Omega$  for the best trade-off between reliability and power loss of the MOSFET.
- The  $V_{gs}$  should be as low as possible when the IRLML0040 in OFF state. The Schottky diode like D12 is preferred in the gate drive turn-off loop.
- The filter cap C41 is essential to remove the ripple and noise of the DC bus voltage in the inverter if it is placed far from the bus E-cap.

Design description

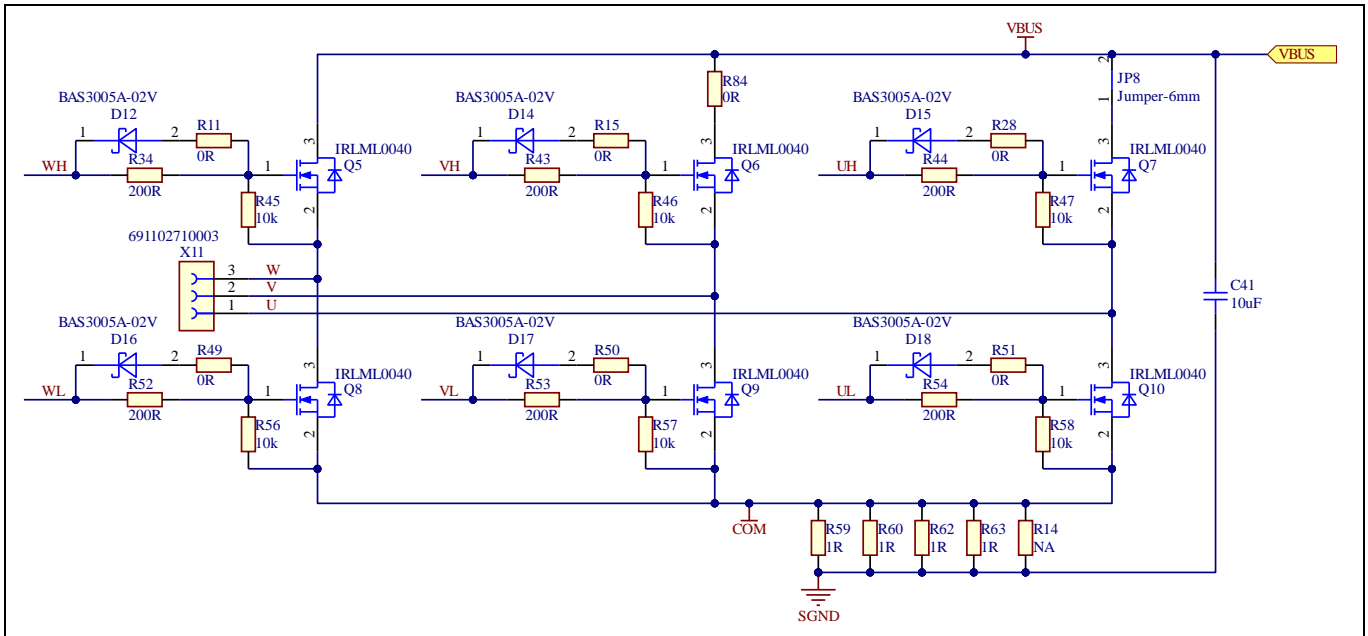

Figure 15 3-phase inverter

6.2.2 DC bus voltage sensing

The DC bus voltage ( $V_{dc}$ ) sensing is used for overvoltage protection (OVP), undervoltage protection (UVP), and DC bus compensation in the firmware.

From Figure 16, R48 and R55 set the bus voltage sensing range from 0 V to 42.5 V. The low-pass filter comprised with R48, R55 and C24 is usually necessary to remove noise at the sensed voltage. C24 should be placed as close as possible to the controller IMD111T-6F040.

Assuming the bandwidth of the low-pass filter is 20 times of the bus voltage fluctuation frequency, here is 100 Hz. The C24 can be calculated as the follows:

$$\frac{1}{2 * \pi * \frac{R48 * R55}{R48 + R55} * C24} = 20 * 100Hz$$

Input R48=150 k  $\Omega$  , R55=20 k  $\Omega$  , yield C24=4.5 nF, herein select 4.7 nF.

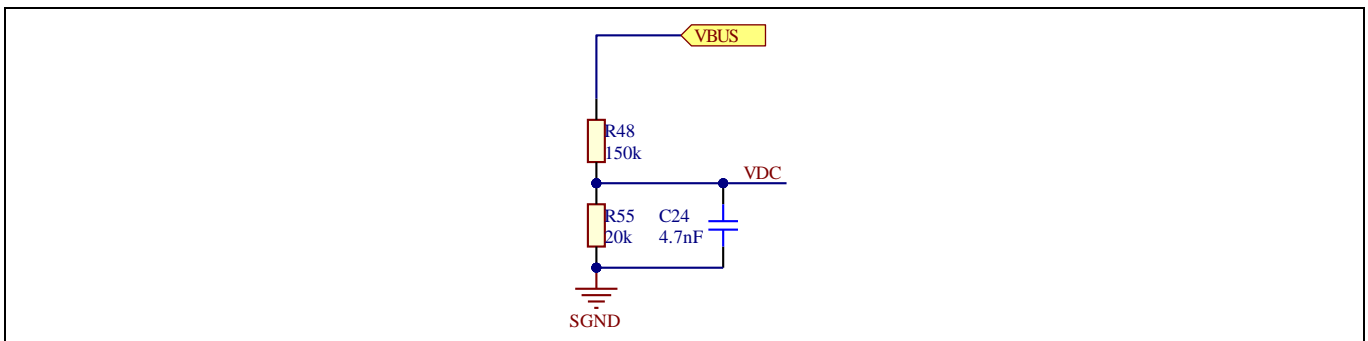
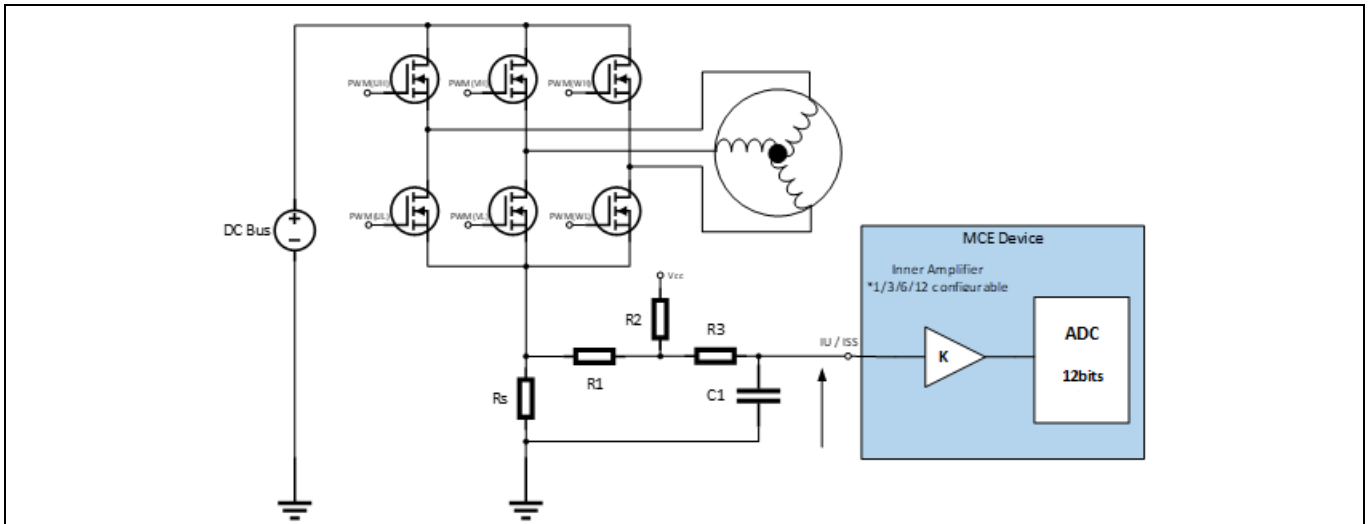

Figure 16 DC bus voltage sensing

### 6.2.3 Motor Current sensing

The motor current sensing configuration of IMD111T-6F040 based on a single-shunt configuration is shown in Figure 17. A level-shift circuit together with a low pass filter is usually adopted to achieve both high accuracy and low noise interference. The filter capacitor C1 in Figure 17 is recommended to be larger than 2 nF.



**Figure 17 Motor current-sensing methodology of IMD111T-6F040**

The average current flowing through the shunt resistor can be calculated as the follows:

$$V_{bus} * I_{avgshunt} = 3 * V_{BEMF} * \frac{\text{max speed}}{1000} * I_{motor} * \cos \Phi$$

Where:

$V_{bus}$ : the DC bus voltage, herein 28 V

$I_{avgshunt}$ : the average current flowing through the shunt resistor

$V_{BEMF}$ : the line-neutral back electromotive force of the BLDC motor, herein 23.6 V/kpm

Max speed: the maximum speed of the motor, herein 385 rpm

$I_{motor}$ : the motor maximum phase current, herein 1.3 A<sub>rms</sub>

$\cos \Phi$ : power factor of the motor, herein 0.9

Input the corresponding data to above function, the calculated average current of shunt resistor is 1.14 A.

Assuming around 1% efficiency loss on the shunt resistor, the 0.3 W power loss for shunt resistor is acceptable. The shunt resistor value can be calculated as the follows:

$$R_{shunt} = \frac{P_{loss}}{I_{avg\_shunt}}$$

Where:

$P_{loss}$ : the allowable power loss of the shunt resistor, herein 0.3 W

$I_{avg\_shunt}$ : the maximum average current of the shunt resistor, herein 1.14 Arms

This yields the shunt resistor value to 0.26  $\Omega$ .

# REF-SHA35IMD111TSYS User guide

## Full-featured starter kit for low voltage ceiling fan motor designs

### Design description

It's selected 0.25 Ω in this application. As a thumb of rule, one surface-mounted resistor in 1206 package can dissipate 1/4 of its rated power in natural cooling condition. Herein four resistors of 1.0 Ω/0.25 W in 1206 package are in parallel configuration for 0.3 W power dissipation.

Assuming the current sensing range is -1 A to 5 A, the current gain can be calculated as the follows:

$$current\_gain = \frac{V_{ref\_ADC}}{R_{shunt} * (I_{max} - I_{min})}$$

Where:

$V_{ref\_ADC}$ : the reference voltage for ADC, equal to the power supply voltage, herein 5 V

$I_{max}$ : the upper limit of current sensing, herein 5 A

$I_{min}$ : the lower limit of current sensing, herein -1 A

$R_{shunt}$ : the shunt resistor value, herein 0.25 Ω

This yields the current gain to 3.33. The closest internal ADC current gain setting of the IMD111T-6F040 is 3. So, the recommended gain of internal ADC is set to 3.

The shunt current is fed back into the controller analogue-to-digital converter (ADC) port. The current sensing circuit is shown in Figure 18.

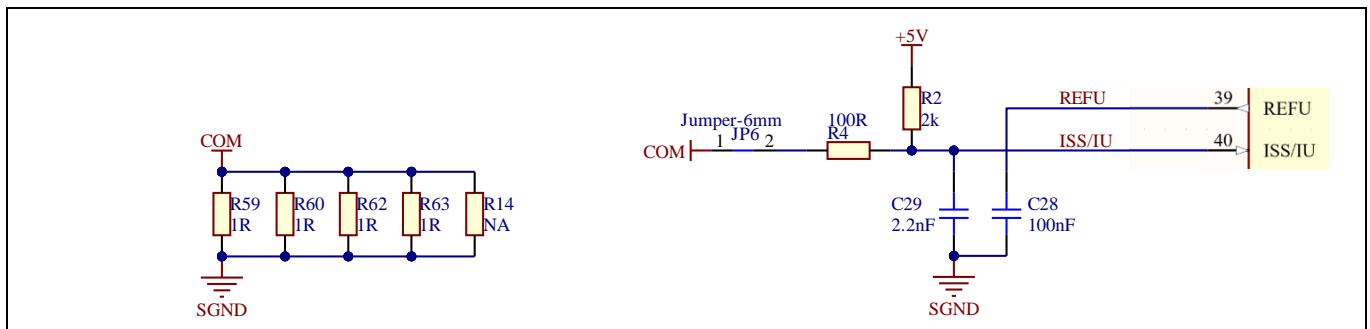

**Figure 18 Motor current sensing on the board**

The offset voltage can be calculated as the follows:

$$V_{offset} = 5V * \frac{R4}{R2 + R4} = -I_{min} * R_{shunt} * \frac{R2}{R2 + R4}$$

Input  $I_{min}=-1$  A,  $R_{shunt}=0.25$  Ω, yields  $R2=20 * R4$ . Considering the power loss, the pull up resistor R2 is usually in several kΩ range. Herein R2 is selected to 2 kΩ and R4 to 100 Ω.

A low-pass filter comprised of R2, R4 and C29 is necessary to remove the noise on the current sensing voltage. Assuming the low-pass filter bandwidth of the current sensing is 40 times of the switching frequency (16 kHz), the C29 can be calculated as the follows:

$$\frac{1}{2 * \pi * \frac{R2 * R4}{R2 + R4} * C29} = 40 * 16kHz$$

Input R2= 2 kΩ, R4=100 Ω, yields C29=2.6 nF, herein select to 2.2 nF.

## Design description

## 6.2.4 Motor overcurrent protection (OCP)

The motor OCP methodology of IMD111T-6F040 based on the single-shunt configuration is shown in Figure 19. The current sensing voltage is compared with the REFU pin inside the controller. This OCP threshold is entered into the iSD [10].

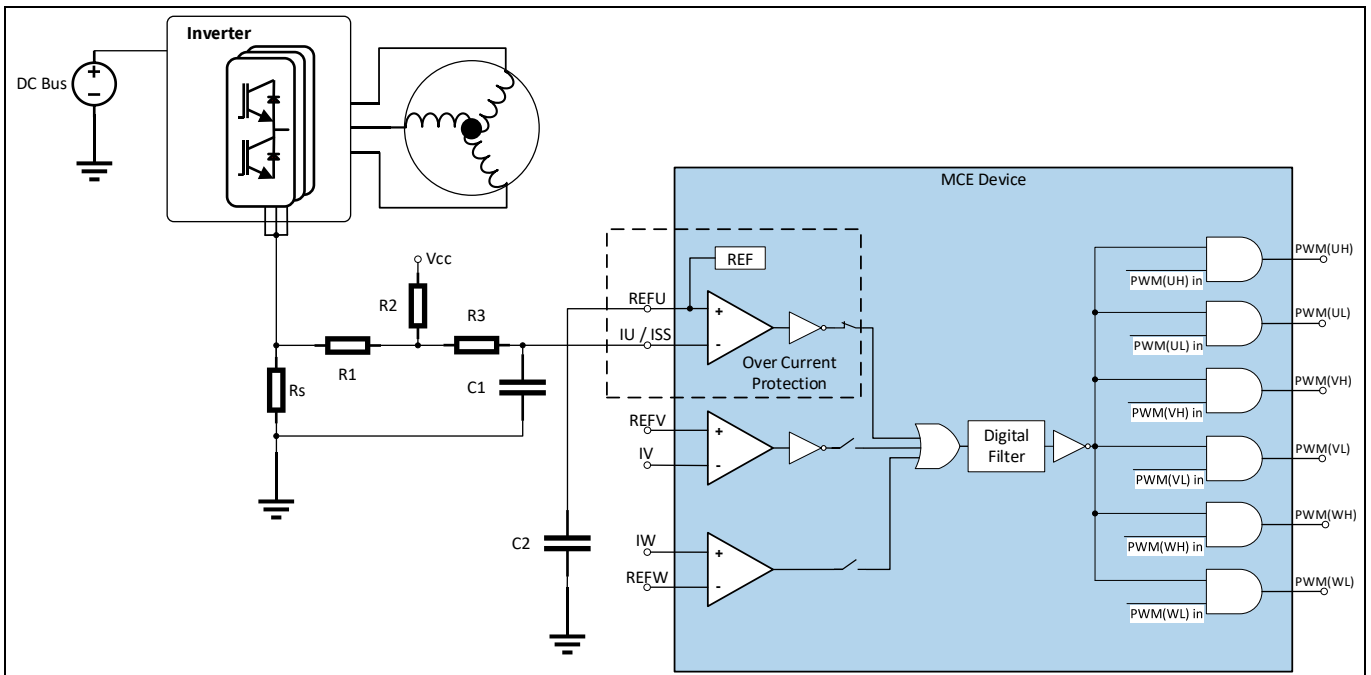

**Figure 19** Motor overcurrent protection topology

The pin REFU needs to be connected to a capacitor to improve noise rejection (e.g., a 100 nF/25 V capacitor, such as C28 in Figure 18).

The OCP threshold should be set properly to protect motor and devices. In this board the OCP threshold is arbitrarily set to 2.5 A.

## 6.3 IMD111T-6F040

### 6.3.1 Power supply of IMD111T-6F064

IMD111T-6F064 can work in a VCC range from 12 to 16.5 V [5]. As the inverter MOSFET IRLML0040 has a maximum gate-source voltage ( $V_{gs}$ ) of 16 V, VCC is selected as 12 V to ensure reliability. The 12 V VCC is generated through an LDO from the main output 28 V as shown in Figure 20. The power dissipation of the LDO is around 0.25 W considering 15 mA supply current of the IMD111T-6F040.

The 12 V VCC and 5 V VDD pass capacitors of IMD111T are necessary and the use of surface-mounted ones with small parasitic inductances, such as C2, C9, C36, C12, C13, and C18 shown in Figure 20 is recommended.

Design description

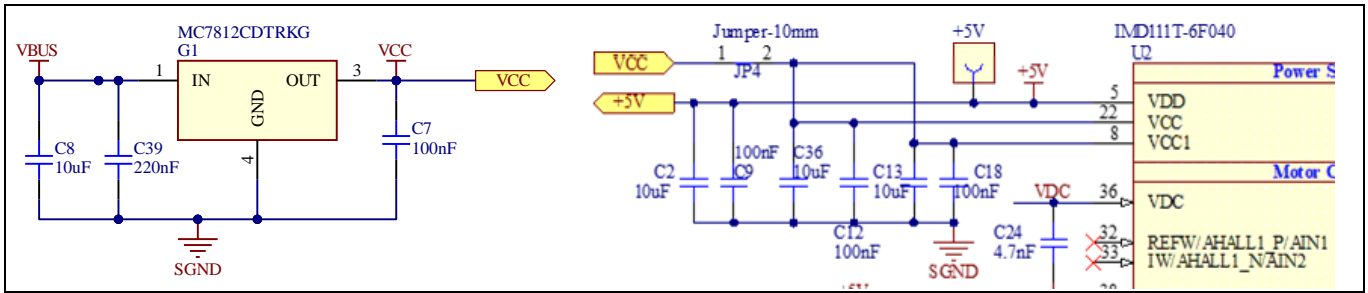

Figure 20 Power supply of IMD111T-6F064

### 6.3.2 Bootstrap capacitors

IMD111T combines a 3-phase gate driver based on the silicon-on-isolator (SOI) technology. The gate driver integrates the bootstrap resistors and a bootstrap diodes intrinsically. Therefore, only the external bootstrap capacitors are needed, as shown in Figure 21.

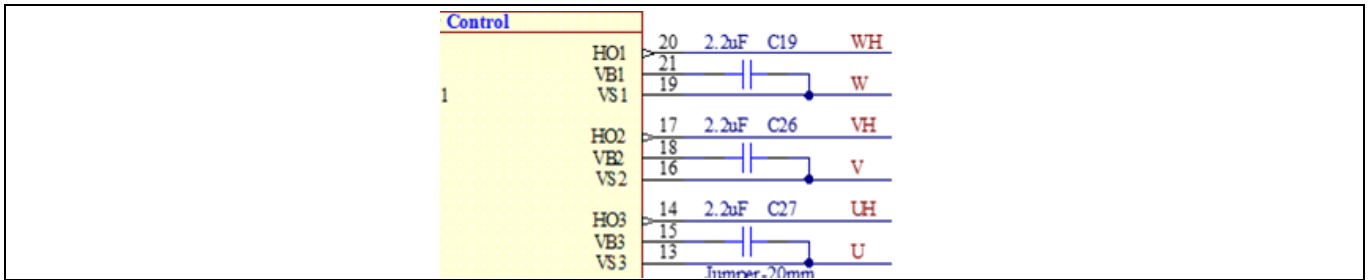

Figure 21 Bootstrap capacitors

The bootstrap capacitors C19, C26, and C27 should be properly scaled such that they are large enough to hold the VBS above Undervoltage lockout (UVLO) level during the discharge period, whereas not too large to be fully charged during the pre-charge period.

the minimum bootstrap capacitor is constrained by the follows [11]:

$$(VCC - V_f - V_{dson} - VBS_{UVLO}) * \left(1 - e^{-\frac{t_{on}}{R_{boot} * C_{boot}}}\right) > \frac{Q_g + (I_{k_{gate}} + I_{QBS}) * t_{off}}{C_{boot}}$$

The maximum bootstrap capacitor is constrained by the follows:

$$(VCC - V_f - V_{dson}) * \left(1 - e^{-\frac{t_{pre-charge}}{R_{boot} * C_{boot}}}\right) > VBS_{UVLO}$$

Where,

VCC: Power supply of the gate driver, 12 V

V<sub>f</sub>: Forward voltage drop of the boot diode, maximum 1.3 V

V<sub>dson</sub>: Voltage drop of the low-side MOSFET when charging the high-side gate driver, around 0.08 V

VBS<sub>UVLO</sub>: Undervoltage lockout (UVLO) of the high-side gate driver supply, maximum 9.8 V

R<sub>boot</sub>: Bootstrap resistor integrated in the gate driver, maximum 60 Ω

C<sub>boot</sub>: Bootstrap capacitor of the high-side gate driver power supply

$t_{on}$ : Maximum turn-on time of the high-side MOSFET, herein 60  $\mu$ S

$t_{off}$ : Minimum turn-on time of the low-side MOSFET, herein 60  $\mu$ S

$Q_g$ : Total gate charge of the MOSFET, maximum 3.9 nC

$I_{kgate}$ : Gate-source leakage current of the MOSFET, maximum 100 nA

$I_{QBS}$ : Leakage current of the high-side gate driver circuit, maximum 400  $\mu$ A

$t_{pre-charge}$ : the active pre-charge time of the bootstrap capacitor. When setting the pre-charge time to 10 mS, this value equals  $10 \text{ mS}/3=3.33 \text{ mS}$

Entering data into above equations, the calculated bootstrap capacitor value is in the range of 51 nF to 22.4  $\mu$ F. Herein selects 2.2  $\mu$ F surface-mounted capacitor in 0805 package.

## 6.4 Infrared remote control

### 6.4.1 Infrared signal processing on the companion board

The IR companion board contains the infrared receiver IRM-3638T and a connector J3 for linking to the main board.

The configuration of the IR receiver IRM-3638T is shown in Figure 22. It's recommended to add a low-pass filter (R73 and C32) at the +5 V power supply. An external pull up resistor R69 is necessary to increase the slew rate of the IRM-3638T output since it's open-collector.

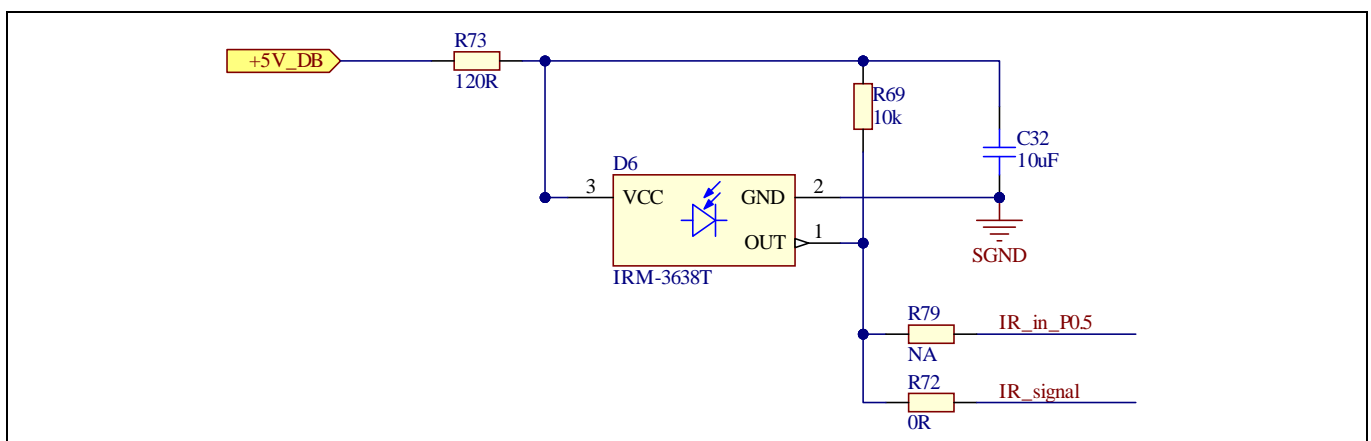

**Figure 22 Configuration of the IR receiver on the companion board**

The output of IRM-3638T is invert logic of the received IR data stream.

For example, when pressing the power ON button on the remote control, the IR data stream of 0x01FE807F will be sent out. The output of the IRM-3638T is shown in Figure 24. After inverting the waveform in **Fehler! Verweisquelle konnte nicht gefunden werden.**, the user can get the IR data stream of 0x01FE807F which is compliant with NEC protocol, as shown in Figure 24 **Error! Reference source not found.**



Design description

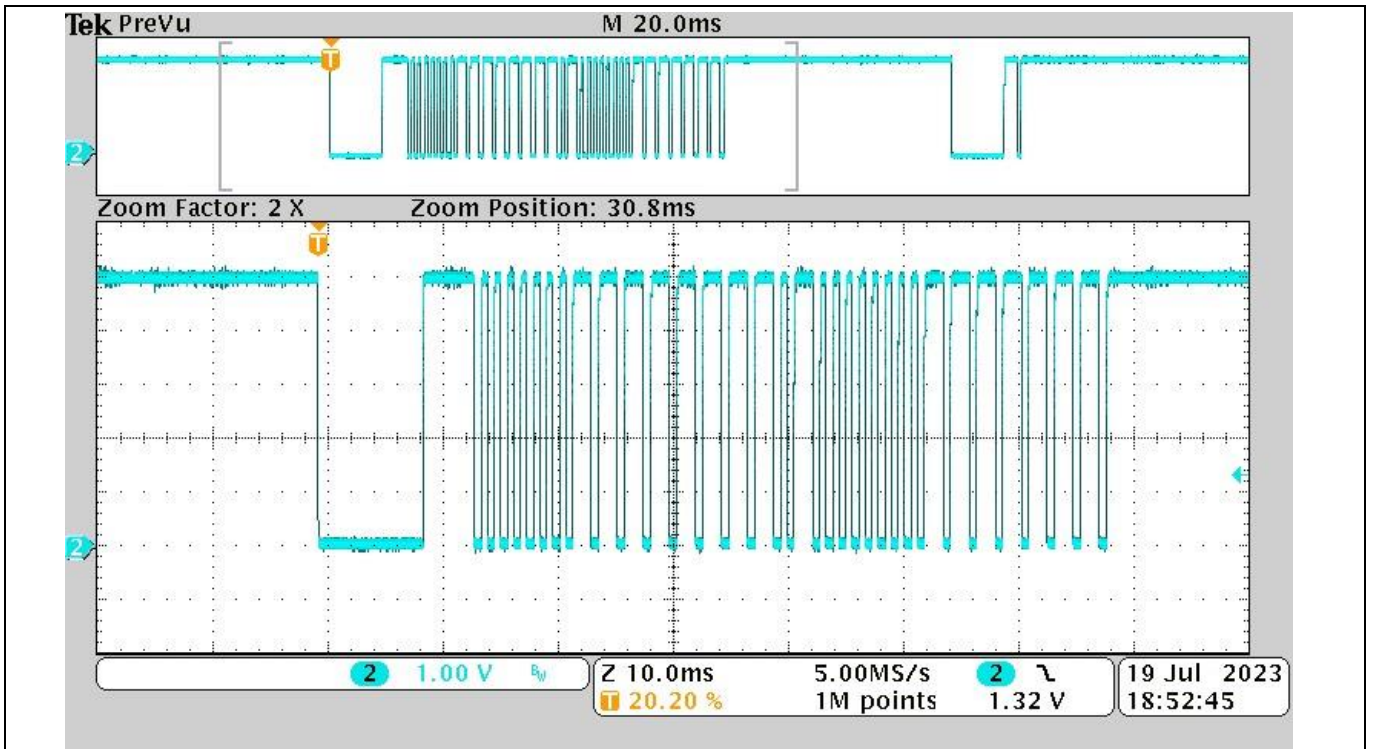

Figure 23 Output of the IRM-3638T when pressing the Power ON button

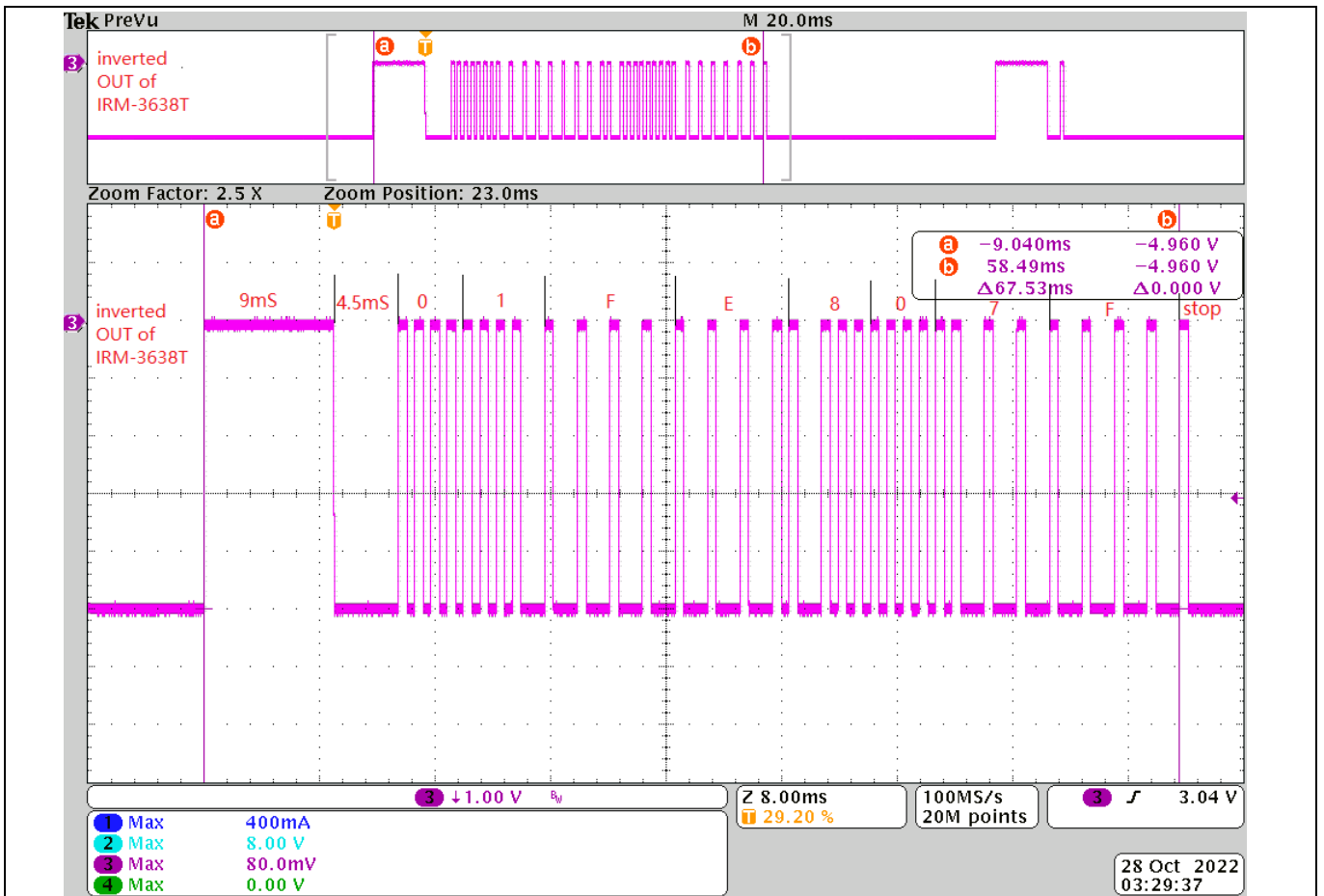

Figure 24 The IR data stream of 0x01FE807F when pressing the Power On button

### 6.4.2 Infrared signal input on the main board

The IR data stream is input to the VSP pin of the IMD111T. To remove the noise at the VSP pin, a low pass filter R13 and C14 is recommended and placed close to the controller.

In case of the pull-up resistor as shown in Figure 22, the actual delay time at the rising edge of the pulses inputting to controller is calculated as below:

$$t_{delay} = (R69 + R13) * C14 = (10k + 120R) * 1nF = 10.12uS$$

The delay time is around 10 uS which doesn't affect the pulse recognition since the minimum pulse width is 526.5 uS.

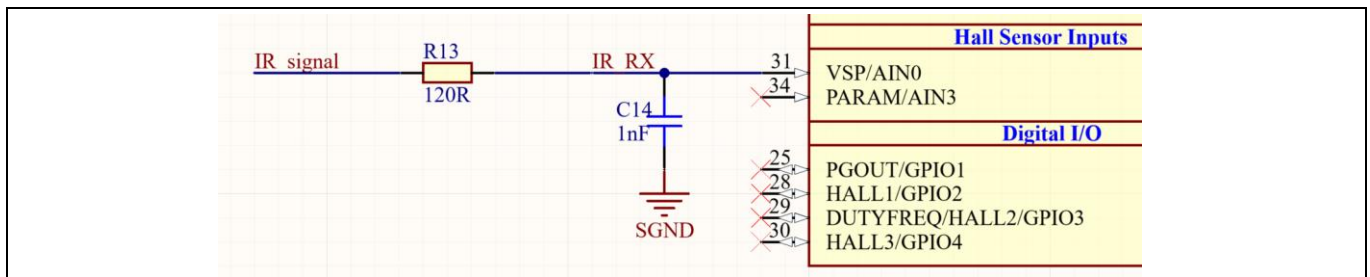

**Figure 25 Infrared signal input on the main board**

## System setup

## 7 System setup

This chapter describes how to get the system working after users have installed the board. Users who are familiar with the system or have already run the board can skip some of the steps mentioned, depending on the situation. For in-depth startup requirements, please refer to the MCE reference manual or the corresponding reference material [9][10].

### 7.1 System connection

The system connection for driving a low voltage ceiling fan is shown in Figure 26.

The [iMOTION™ link](#) is needed to bridge the PC/debugger and motor drive system (the target iMOTION™ device) with 1 kV DC galvanic isolation. For more information on the iMOTION™ link, refer to Section 9.3.

1. Connect iMOTION™ link's 8-pin cable to main board J1 using the default pin order (only pin 5~8 are used) and connect the PC and iMOTION™ link with a USB wire.
2. Connect AC power supply (L, N) and motor (X11).
3. Connect main board J2 to companion board J3 by the accessory cable provided in the package box.

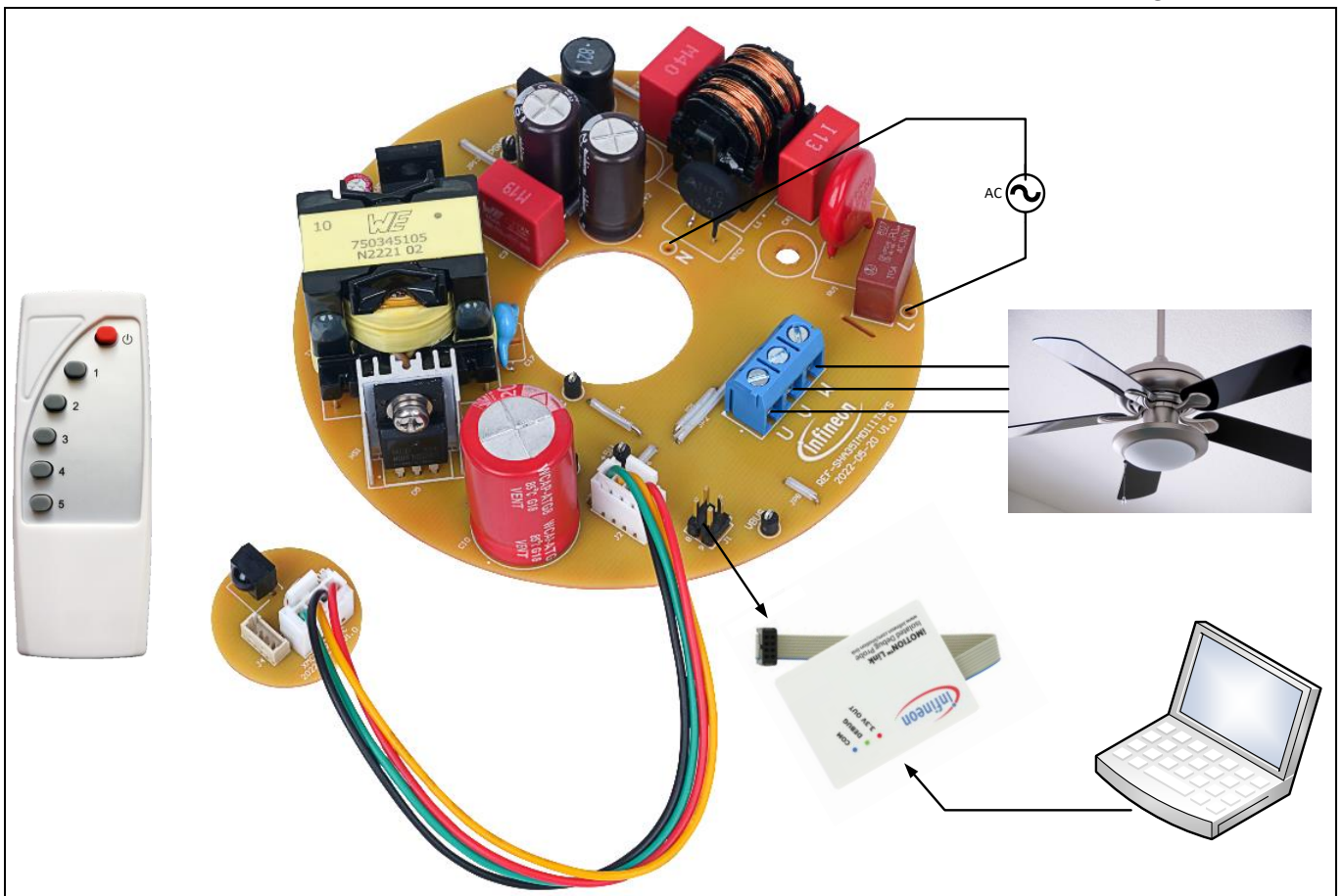

**Figure 26** Hardware connection details

*Note:* The iMOTION™ link shown in Figure 26 is required for programming and debugging, but it is not included in the delivery content. It can be ordered separately as per details given in Section 9.3.

System setup

## 7.2 iMOTION™ development tool

### 7.2.1 iMOTION™ Solution Designer and SDpak

The iMOTION™ software tool – iMOTION Solution Designer (iSD), accompanying with the SDpak is required to set up the system. The iSD can be downloaded from Infineon’s website—<http://www.infineon.com/imotion-software>. Please check this page periodically for the updates. Regarding the use of the iSD, please refer to [9] [10], available in the installation path of this tool.

Note: This reference board has been tested using iSD v1.1.1 with SDpak version V5.01.18.

### 7.2.2 Key parameters configuration in iSD

The users have to input the detailed parameters into iSD to control and fine-tune the system performance. The iSD configuration wizard page is shown in Figure 27.

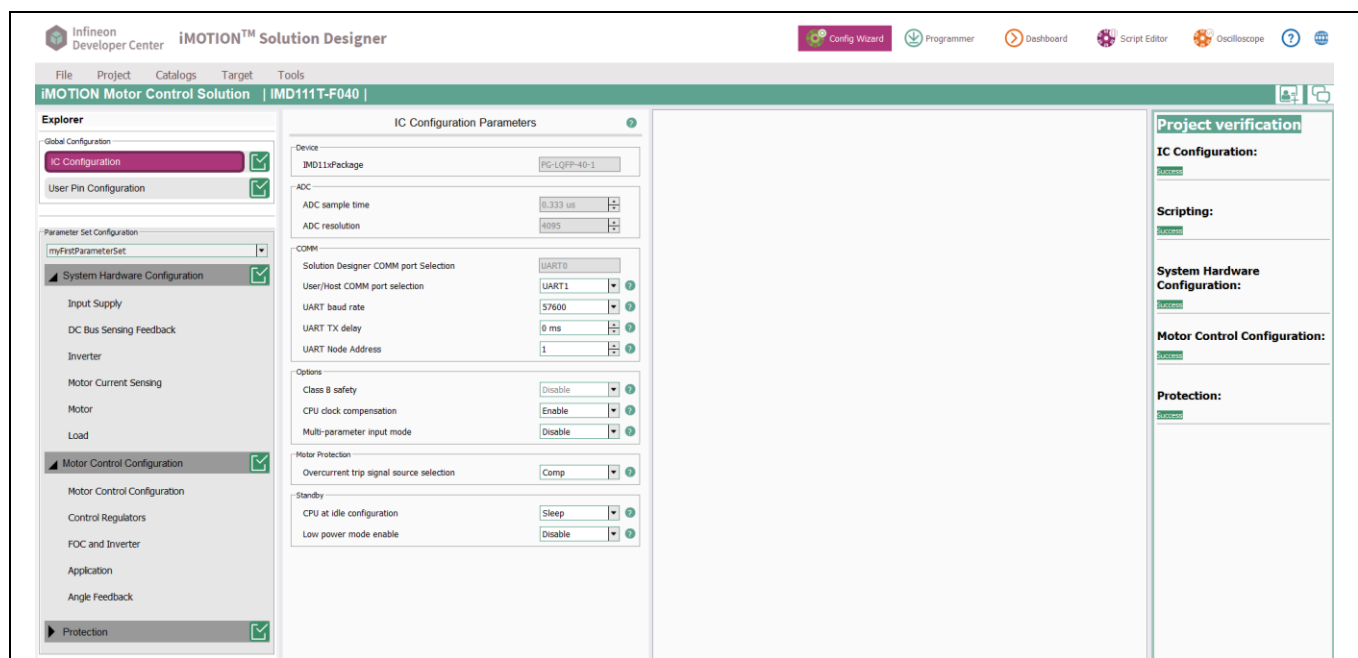

Figure 27 iSD Configuration Wizard page

The key parameters configuration for this reference board are listed in Table 9.

Table 9 Key parameters configuration

Parameter	Value	Comment	
IC configuration	CPU at idle configuration	Sleep	Less controller power consumption in standby
System hardware configuration	Input supply	5 V	The controller supply voltage
	DC bus sensing upper resistor	150 kΩ	Real value on the board, See Figure 16
	DC bus sensing lower resistor	20 kΩ	
	Motor current feedback shunt	250 mΩ	Single shunt value on the board
	Motor feedback circuit voltage offset (voff)	238.10 mV	Real value on the board,

## System setup

Parameter	Value	Comment	
Motor feedback circuit current gain	238.10 mV/A	See Figure 18	
Motor control configuration	PWM frequency	16.0 kHz	Switching frequency of the inverter
	SVPWM over modulation	Disable	
	DC bus compensation	Enable	It is required to compensate the fluctuation of the DC bus voltage
	Motor starting method	Direct	For the smooth startup and avoiding the reverse rotation at startup
	Motor angle initialization	Initial angle sensing	
	Direct start maximum speed threshold	125 rpm	
	Catch spin before start	Enable	
Protection	Overcurrent comparator current trip level (peak)	2.5 A	
	DC bus critical overvoltage fault level	32 V	
	DC bus overvoltage fault level	31 V	
	DC bus undervoltage fault level	20 V	

## 7.3 Script code of the infrared remote control

### 7.3.1 Infrared remote control and speed setting

The motor speed can be set by the infrared (IR) remote control, which is implemented by the script [9].

The relationship between the remote control, the variables in the script, and the target speed setting for this design is listed in Table 10.

**Table 10 The remote control, IR command, variables in script, and target speed setting**

Remote control	Infrared signal	'APP_MOTOR0.Command' in script (in counts)	'APP_MOTOR0.TargetSpeed' in script (in counts)	Target speed (rpm)
Power OFF	0x01FE807F	0	0	0
Power ON		1	Last speed saved	Last speed saved
1	0x01FE58A7		5319	125
2	0x01FE40BF		8085	190
3	0x01FEC03F		10851	255
4	0x01FE609F		13617	320
5	0x01FEA05F		16383	385

### 7.3.2 Description of the script code

Please refer to [12] and section 9.4.

The script mainly implements the ON/OFF function of the motor and different speed commands. It also supports the saving last speed setting function. The variable TARGET\_SPEED\_X(X=1,2,3,4,5) in the script can be

### System setup

set to the target speed as Table 10, or it can be set to the desired speed according to user needs. At the same time, the script supports repeated command operations, so it can also be set as an acceleration or deceleration function. In this example script code, the code is placed in Task1 with execution period of 50ms.

## Test results

## 8 Test results

The system has been tested with a real ceiling fan load. The settings in the iSD have been fine-tuned as per instructions in Section 7.2.2. Customers should adjust the parameters if using a different motor load.

### 8.1 System test with IR remote control

With IR remote control, the ceiling fan runs at five different speeds. The system test data are listed in Table 11. The AC input current under 230 V<sub>rms</sub> and at maximum speed is sinusoidal as shown in Figure 28.

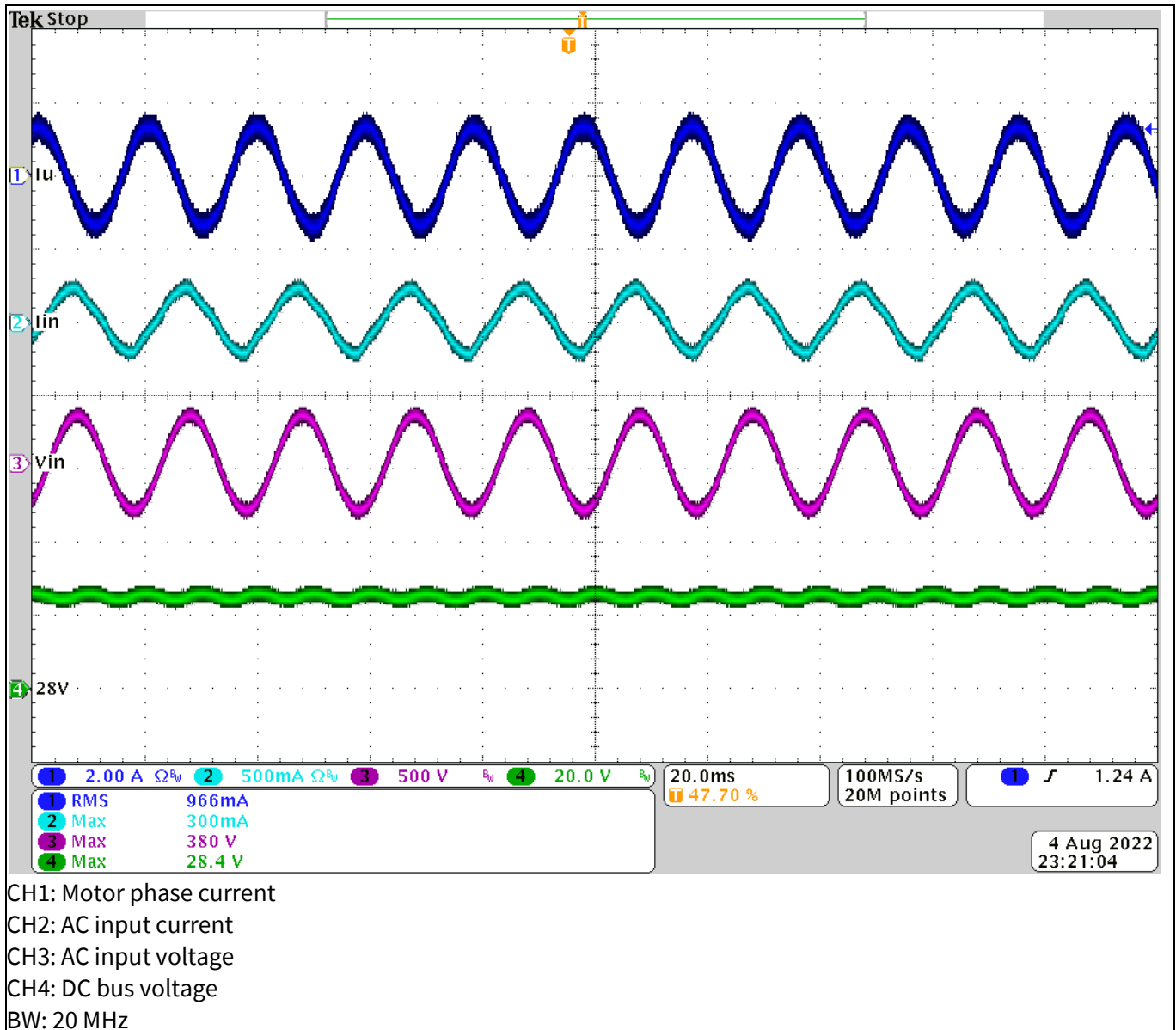

**Figure 28** The AC input current at 230 V<sub>rms</sub> and maximum speed

The system test result with IR remote control is listed in Table 11. The real speed is well-regulated with a variation less than 2%, the PF value is above 0.95, and the iTHD is less than 10% at maximum output power under 230 V<sub>rms</sub> AC input.

## Test results

Table 11 System test result with IR control

Vin (Vrms)	IR remote control	Target speed (rpm)	Measured speed (rpm)	Speed error (%)	DC bus (Vdc)	Pin (W)	Pout (W)	Efficiency (%)	PF	iTHD (%)
90, 50 Hz	OFF	0	0			0.93				
	1	125	126.3	1.0	27.84	3.52	1.99	56.53	0.940	5.1
	2	190	191.8	0.9	27.84	6.82	5.01	73.46	0.982	4.8
	3	255	257.5	1.0	27.82	12.81	10.32	80.56	0.994	3.4
	4	320	322.6	0.8	27.81	22.37	18.68	83.50	0.997	3.4
	5	385	387.1	0.5	27.79	35.82	29.58	82.58	0.998	3.5
120, 50 Hz	OFF	0	0		27.85	0.94				
	1	125	126.3	1.0	27.85	3.45	1.97	57.10	0.850	6.9
	2	190	191.8	0.9	27.84	6.84	4.99	72.95	0.951	4.6
	3	255	257.5	1.0	27.82	12.67	10.32	81.45	0.984	3.7
	4	320	322.6	0.8	27.81	21.78	18.48	84.85	0.993	3.3
	5	385	387.1	0.5	27.80	34.84	29.76	85.42	0.995	4.8
150, 50 Hz	OFF	0	0		27.84	0.95				
	1	125	126.3	1.0	27.84	3.46	1.98	57.23	0.726	9.3
	2	190	191.8	0.9	27.84	6.71	4.91	73.17	0.893	5.8
	3	255	257.5	1.0	27.84	12.44	10.38	83.44	0.962	4.7
	4	320	322.6	0.8	27.82	21.35	18.15	85.01	0.985	3.6
	5	385	387.1	0.5	27.79	35.04	29.74	84.87	0.990	4.7
180, 50 Hz	OFF	0	0		27.84	0.94				
	1	125	126.3	1.0	27.84	3.45	1.96	56.81	0.605	11.8
	2	190	191.8	0.9	27.83	6.56	4.57	69.66	0.816	7.3
	3	255	257.5	1.0	27.82	12.48	10.08	80.77	0.928	5.4
	4	320	322.6	0.8	27.82	21.33	18.12	84.95	0.970	3.9
	5	385	387.1	0.5	27.79	34.51	29.66	85.95	0.985	4.6
230, 50 Hz	OFF	0	0		27.84	0.94				
	1	125	126.3	1.0	27.84	3.48	1.96	56.32	0.440	14.7
	2	190	191.8	0.9	27.84	6.73	4.88	72.51	0.668	6.7
	3	255	257.5	1.0	27.83	12.43	10.05	80.85	0.847	6.4
	4	320	322.6	0.8	27.82	21.29	17.87	83.94	0.927	5.4
	5	385	387.1	0.5	27.79	34.71	29.88	86.08	0.966	5.6
264, 50 Hz	OFF	0	0		27.84	0.96				
	1	125	126.3	1.0	27.84	3.51	1.96	55.84	0.363	16.2
	2	190	191.8	0.9	27.84	6.79	4.96	73.05	0.576	12.3
	3	255	257.5	1.0	27.83	12.52	10.10	80.67	0.775	7.6
	4	320	322.6	0.8	27.82	21.53	18.12	84.16	0.889	6.2
	5	385	387.1	0.5	27.79	34.48	29.66	86.02	0.945	6.5
300, 50 Hz	OFF	0	0		27.85	0.97				
	1	125	126.3	1.0	27.85	3.56	1.95	54.78	0.301	17.1
	2	190	191.8	0.9	27.84	6.82	4.87	71.41	0.485	13.8
	3	255	257.5	1.0	27.84	12.47	10.12	81.15	0.697	9.5
	4	320	322.6	0.8	27.83	21.55	18.16	84.27	0.843	6.8
	5	385	387.1	0.5	27.81	34.53	29.73	86.10	0.916	8.1



## Test results

## 8.2 Voltage stress of the AC/DC MOSFET and rectifier diode

When the input AC voltage reaches  $340 V_{rms}$  at maximum load, the board will trigger the input overvoltage protection. In this condition primary switch Q2 and secondary rectifier diode D5 of the AC/DC converter have the largest voltage stress.

As shown in Figure 29, the maximum drain-source voltage ( $V_{ds}$ ) of Q2 is 700 V, which still has over 10% margin of its 800 V rating [6]. The maximum reverse voltage ( $V_{ka}$ ) of the rectifier diode is 158 V, which still has over 20% margin of its 200 V rating.

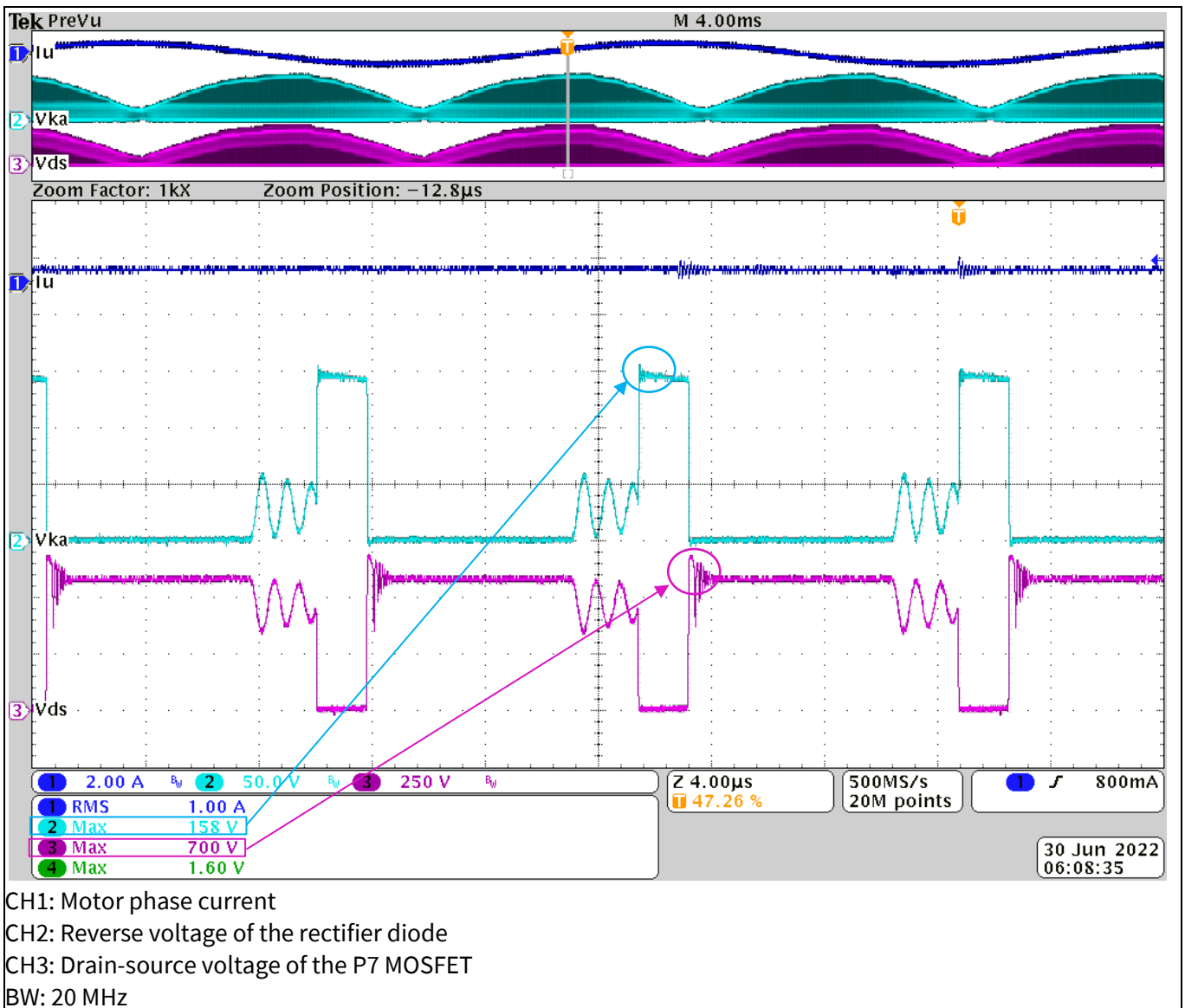

**Figure 29** Waveforms of the AC/DC converter at  $340 V_{rms}$  with maximum load

Test results

### 8.3 DC bus, VCC, and VDD regulation at power ON/OFF

As shown in Figure 30, the 28 V DC bus has an overshoot at startup and motor-stop due to slow feedback loop response to achieve a high PF value. It is stable when the motor running. VCC (12 V) and VDD (5 V) are well-regulated under any work conditions.

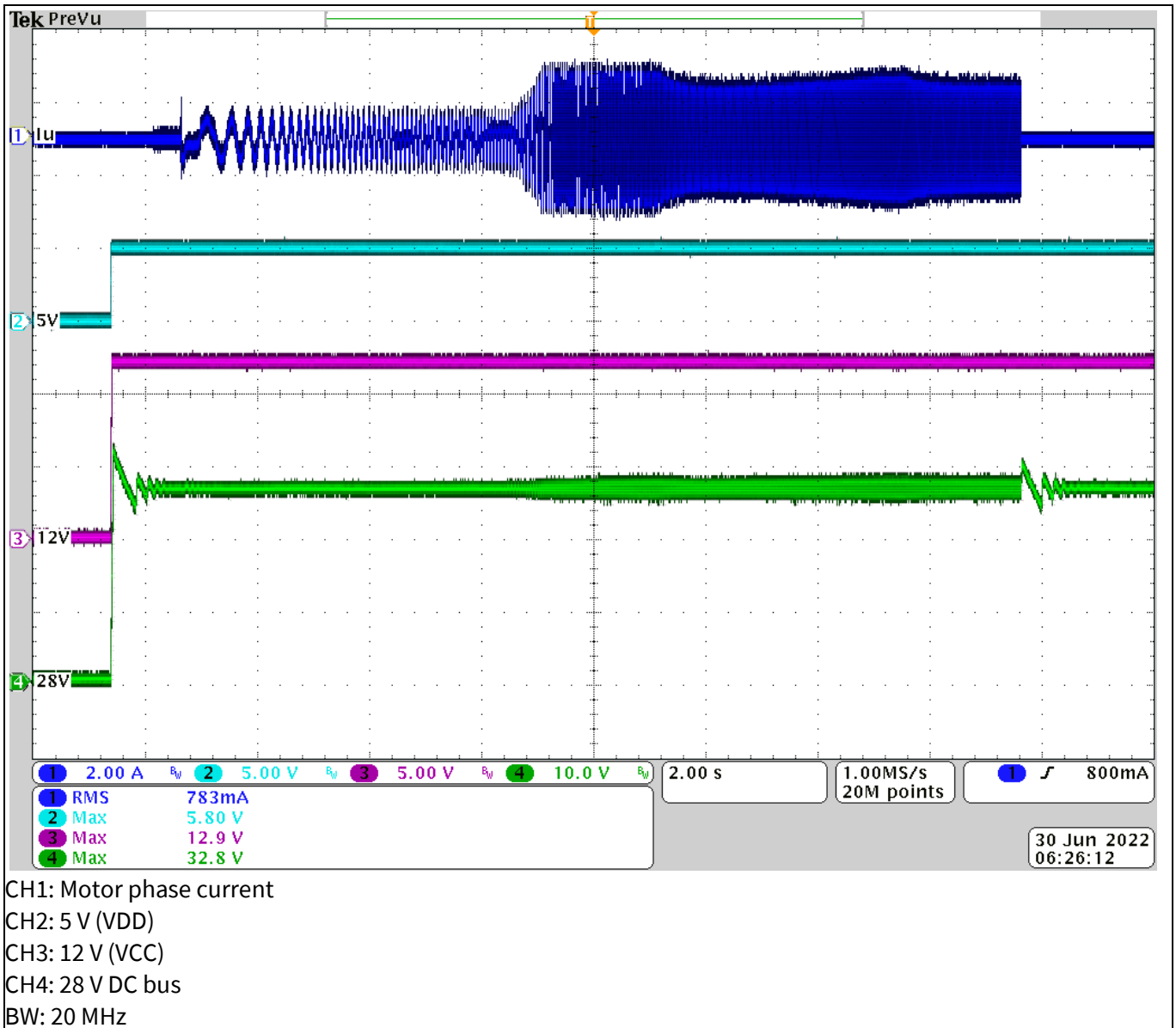

Figure 30 28 V, 12 V, and 5 V regulations at 230 V<sub>rms</sub> power ON/OFF at maximum speed

Test results

### 8.4 Gate drive and voltage stress of the inverter MOSFET

The gate-source voltage ( $V_{gs}$ ) of the inverter MOSFET (like Q8) is limited to 0.55 V, which is far below the minimum turn-on threshold (1 V), as the cursor marked in Figure 31. The maximum drain-source voltage ( $V_{ds}$ ) is 30.2 V, which has over 20% margin of its 40 V rating.

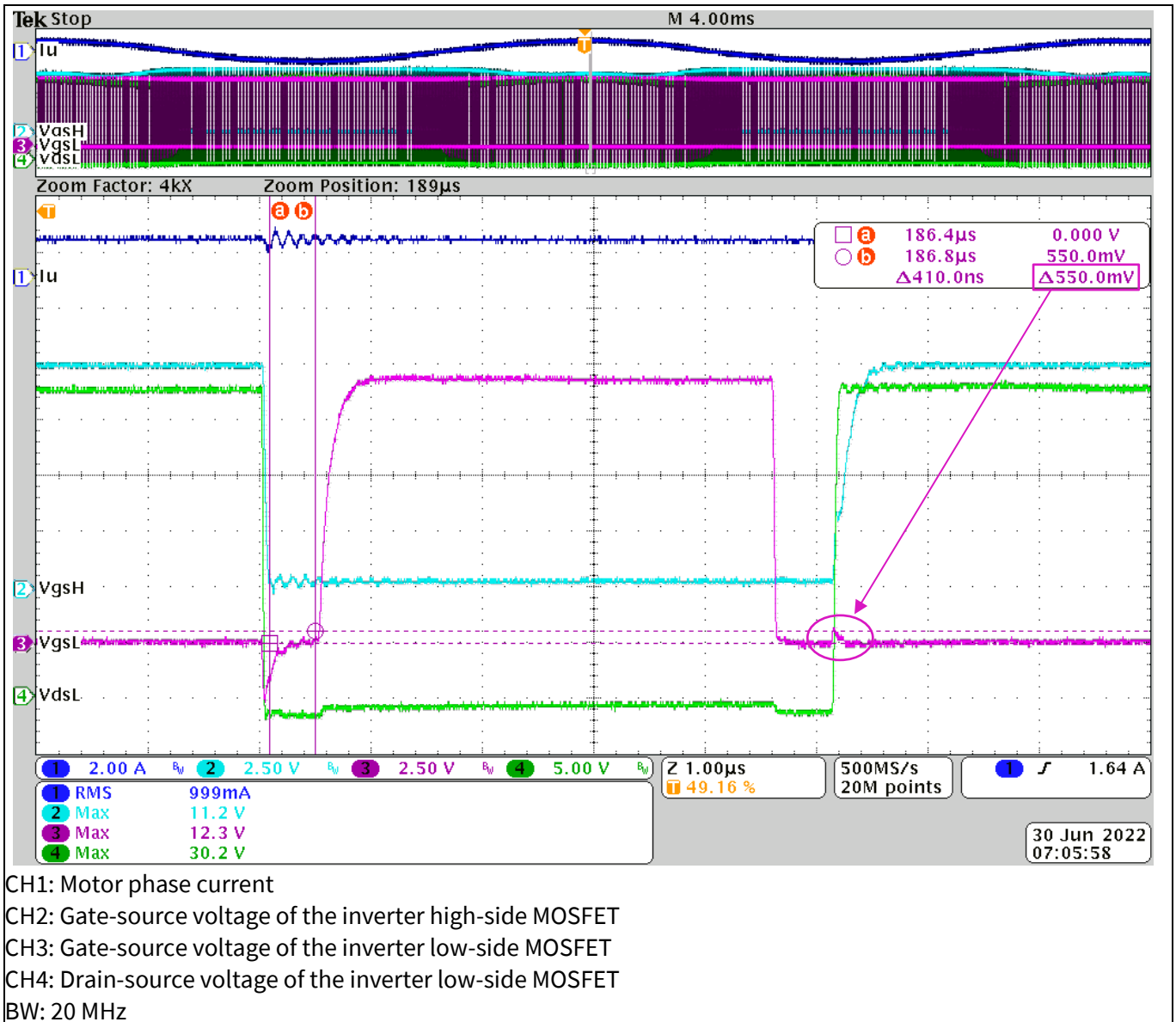

Figure 31 The inverter MOSFET voltage stress at 230 V<sub>rms</sub> at maximum speed

Test results

8.5 Motor running performance

8.5.1 Motor startup from zero-speed

If the catch-spin function is enabled in the iSD, the motor will enter the catch-spin stage at each startup to detect the motor’s current speed and spinning direction [10].

When starting from speed zero, the motor will execute the zero-speed catch-spin mechanism and then enter the initial angle sensing stage as the current speed is zero. After startup, the motor runs to the target speed with the ramp rate limit which can be preset in the iSD [10].

The motor startup behavior from zero speed is shown in Figure 32.

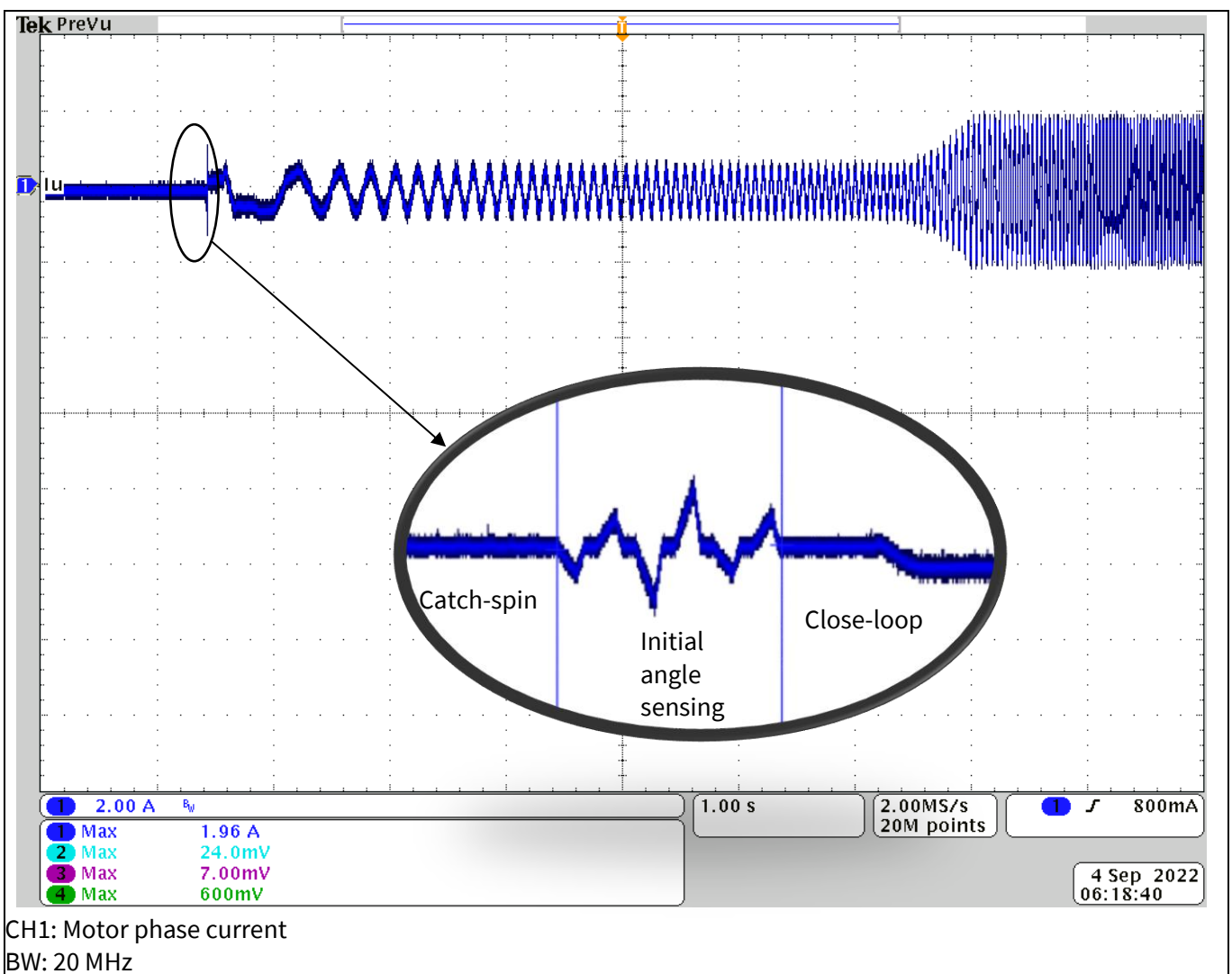

Figure 32 The motor phase current at startup

Test results

### 8.5.2 Motor forward catch-spin

If the catch-spin function is enabled in the ISD, the motor will enter the catch-spin stage at each startup to detect the motor’s current speed and spinning direction [10].

When a stop command is received, the gate drives shut off and thus, the motor speeds down.

When starting from a non-zero speed, the forward catch-spin mechanism will be executed to check the motor speed and spinning direction. For ceiling fan application, the forward catch-spin is usually required.

The forward catch-spin behavior is shown in Figure 33.

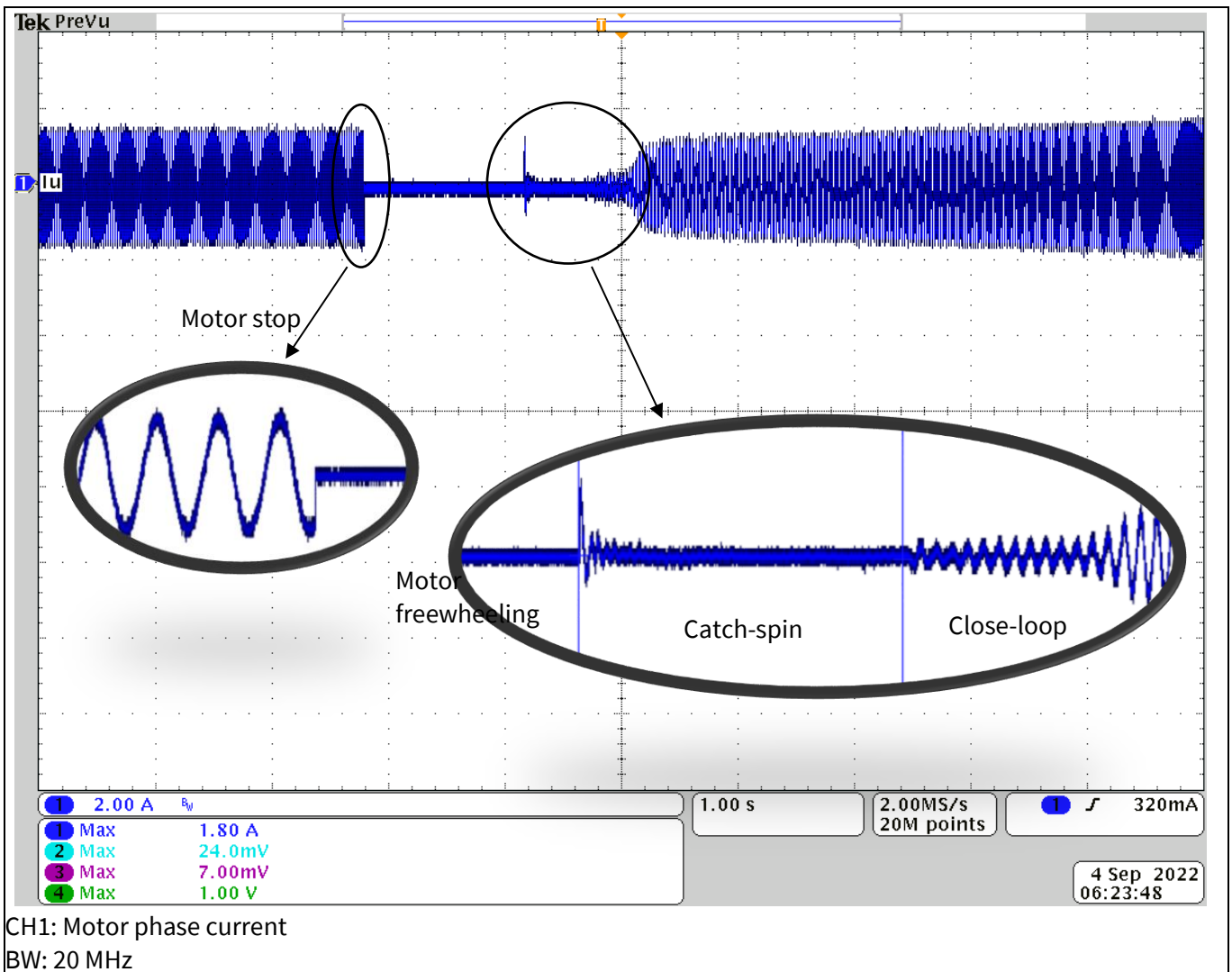

Figure 33 The motor phase current of the forward catch-spin

Test results

### 8.6 Protections

The protections in REF-SHA35IMD111TSYS at system level are listed in Table 12.

**Table 12 Protections**

Protection type	Protection behavior
AC input brown-out	ICL8810 enters brown-out protection, then the DC bus voltage falls, then the motor stops by triggering the DC bus undervoltage fault
AC input overvoltage	ICL8810 enters input overvoltage protection, then the DC bus voltage falls, then the motor stops by triggering the DC bus undervoltage fault

### 8.7 Thermal performance

The board has been tested at both 230 V<sub>rms</sub> and 90 V<sub>rms</sub> input voltages at room temperature. The motor speed is set to 385 rpm at which the input power is 35 W under 230 V<sub>rms</sub> and 36.5 W under 90 V<sub>rms</sub> input. The temperature of the key components is shown in Figure 34 and Figure 35, with temperature rise calculated in Table 13.

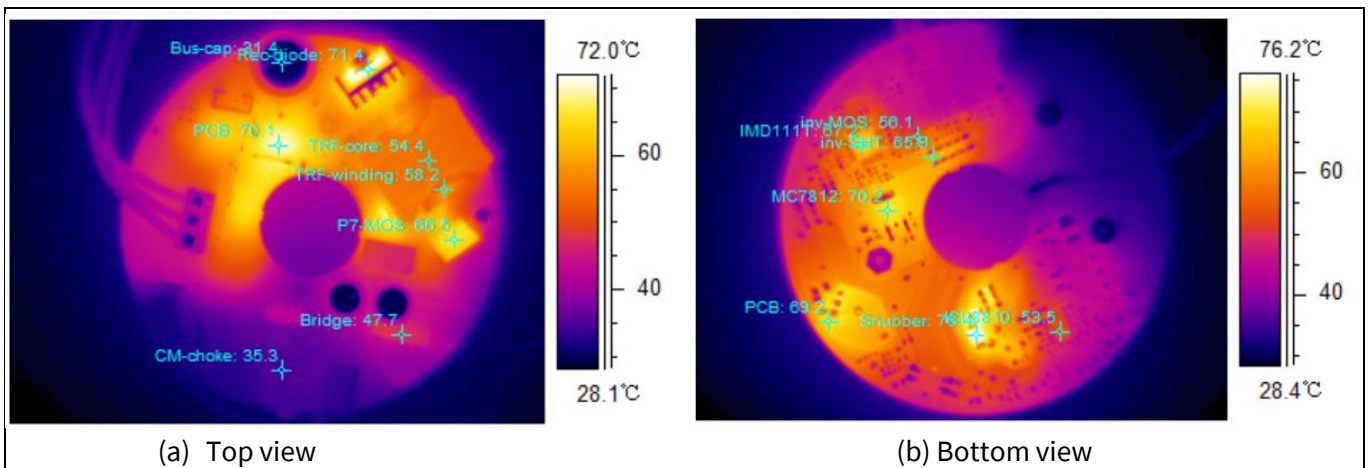

**Figure 34 Thermal test at 230 V<sub>rms</sub>, input power 35 W, room temperature**

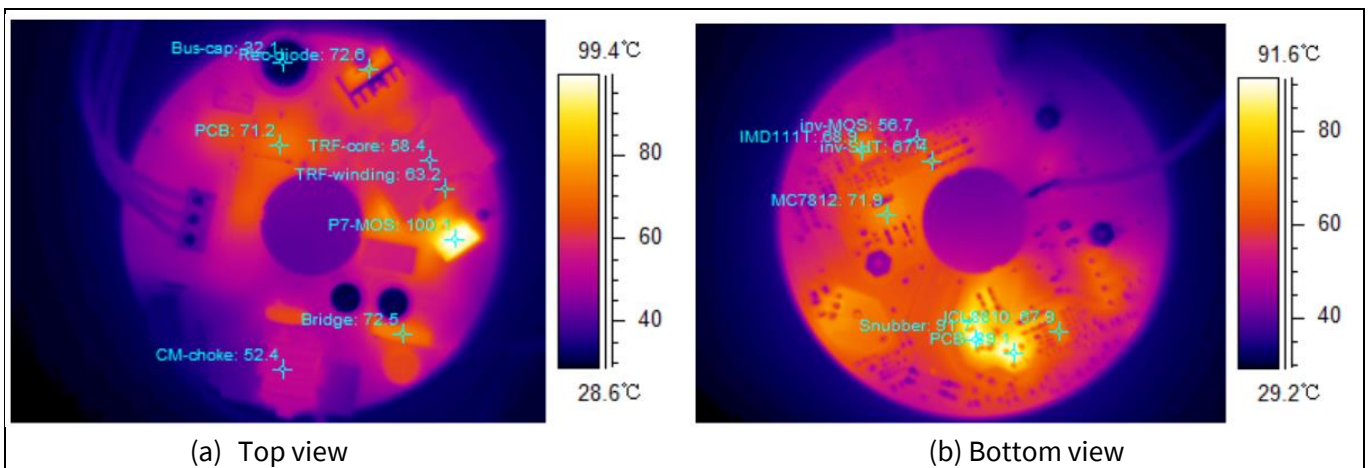

**Figure 35 Thermal test at 90 V<sub>rms</sub>, input power 36.5 W, room temperature**

## Test results

**Table 13** Thermal result at 230 V<sub>rms</sub>, 90 V<sub>rms</sub>, maximum load, ambient room temperature

Component	$\Delta T$ (°C)	$\Delta T$ (°C)	Remark
	@230 V <sub>rms</sub> input	@90 V <sub>rms</sub> input	
Rectifier bridge	19.6	43.8	Case temperature
AC/DC transformer	30.1	34.5	Core/winding which has the higher temperature
AC/DC MOSFET IPA80R1K4P7	38.2	71.5	Case temperature
Flyback controller ICL8810	25.1	39.0	Case temperature
AC/DC rectifier diode MFB10200CT	43.4	43.9	Case temperature
Motor controller IMD111T-6F040	39.0	39.5	Case temperature
Inverter MOSFET IRLML0040	27.8	27.4	Case temperature
Inverter shunt resistor	37.5	38.0	Case temperature

## 8.8 Surge protection

The board passes criteria A of 1.2/50  $\mu$ S 4 kV surge test compliance with IEC 61000-4-5: 2005. The test method is shown in Table 14.

**Table 14** Surge test method

Input voltage (V)	Fan speed (rpm)	Inject line	Polarity	Number	Angle	Voltage (kV)	Time interval (seconds)	Inject method	Complied criteria
230 Vac, 50 Hz	385	L-N	$\pm$	5	0	4.0	60	Direct	A
					90				
					180				
					270				





## Appendices

### 9.2 Abbreviations and definitions

**Table 15 Abbreviations**

Abbreviation	Meaning
CE	Conformité Européenne
EMI	Electromagnetic interference
UL	Underwriters Laboratories

### 9.3 Additional information

To initiate testing, customers are advised to order the iMOTION™ link; detailed information is provided in Table 16.

Infineon components on the board are listed in Table 16 as well. Customers can visit the corresponding webpage for more information.

**Table 16 Additional information on tools and Infineon components**

Base part number	Package	Standard pack		Orderable part number
		Form	Quantity	
iMOTION™ link		Container	1	IMOTIONLINK
ICL8810	PG-DSO-8	Tape and reel	2500	ICL8810XUMA1
IPA80R1K4P7	PG-TO220-3	Tube	500	IPA80R1K4P7XKSA1
BSS126i	PG-SOT23-3	Tape and reel	3000	BSS126IXTSA1
IRLML0040	SOT23	Tape and reel	3000	IRLML0040TRPBF
IMD111T-6F040	PG-LQFP-40	Tape and reel	1500	IMD111T6F040XUMA1
BAS3005A-02V	SC79	Tape and reel	3000	BAS3005A02VH6327XTSA1

### 9.4 Script code

**Code Listing 1 Global variables**

```

001      /*****
002          *****/
003      /*Global variables*/
004      /*****
005          *****/
006      /* status variables */
007      int32_t IR_status;
008      int32_t IR_DriverStatus;
009      uint8_t protocol;
010      uint8_t RawDataAvailable;
011      uint8_t RawDataValid;
012      uint8_t DataValid;
013      uint8_t Receiving;
014      uint8_t AddressError;
015
016      /* data and address variables */
017      uint8_t FaultClearCount;

```

## Appendices

## Code Listing 1 Global variables

```

016     uint8_t address;
017     uint8_t command;
018     int32_t buffer;
019     uint8_t address_buffer;
020     uint8_t command_buffer;
021     uint8_t Repeating;
022     int32_t Repeats;
023     uint8_t mask_cnt;
024     int32_t CMD_STATE;
025
026     uint8_t FlashWriteFlag;
027     uint8_t BrownOut_Flag;
028     uint8_t CmdUpdate_Flag;
029
030     uint8_t DCabnormal_count;
031     uint8_t DCnormal_count;
032     uint8_t FlashWrite_Flag;
033     uint8_t FlashStatus;
034     uint8_t FlashEmpty;
035     uint8_t FlashInvalid;
036     uint8_t FlashWriteError;
037
038     CONST int CMD_SPEED_1 = 26;
039     CONST int CMD_SPEED_2 = 2;
040     CONST int CMD_SPEED_3 = 3;
041     CONST int CMD_SPEED_4 = 6;
042     CONST int CMD_SPEED_5 = 5;
043     CONST int CMD_ON_OFF = 1;
044     CONST int TARGET_SPEED_1 = 5319;    //5319 = 125rpm/385rpm*16383
045     CONST int TARGET_SPEED_2 = 8085;
046     CONST int TARGET_SPEED_3 = 10851;
047     CONST int TARGET_SPEED_4 = 13617;
048     CONST int TARGET_SPEED_5 = 16383;
049     CONST int VDC_THRESHOLD = 2313;    //Vdc_Max 42.5V    2313 =
    24V/42.5V*4096
050     CONST int VDC_Hysteresis = 144;    //1.5V    2313 =
    1.5V/42.5V*4096
051
052     CONST int STOP_State = 1;
053     CONST int FAULT_State = 5;
054
055     CONST int MASK = 0;
056     CONST int READY = 1;
057     CONST int MASK_TIME_OUT = 50;
058     CONST int STOP = 1;    //Motor_SequencerState
059     CONST int POWER_ON = 1;
060     CONST int POWER_OFF = 0;
061     CONST int DC_Time_Out = 10;
062     CONST int CMD_FAULT_CLEAR = 1; //CLEARE FAULT
063
064
065     flash uint16_t Power_state;    // Flash storage data
066     flash uint16_t Speed_state;    // Flash storage data
067     flash uint16_t Power_Previous;

```

## Appendices

### Code Listing 1 Global variables

```
068     flash uint16_t Speed_Previous;
      flash uint16_t FlashStorageDataValid; // Flash storage data
```

### Code Listing 2 Script task0

```
069     /*Task0 init function*/
070     Script_Task0_init()
071     {
072
073     }
074     /*****
      *****/
075     /*Task0 init function*/
076     Script_Task0 ()
077     {
078
079     }
```

### Code Listing 3 Script task1

```
079     /*Task1 init function*/
080     Script_Task1_init()
081     {
082         IR_DriverDeInit();
083         /* Initialize IR Interface */
084         /* channel (0-RX0, 1-RX1, 2-VSP), rxinvert, protocol
      (0:RC5, 1:NEC, 2:NECextended), address */
085         IR_DriverStatus = IR_DriverInit(2,1,1,128);
086         FlashStatus = Flash_GetStatus();
087         FlashEmpty = FlashStatus & 0x01;
088         FlashInvalid = FlashStatus & 0x02;
089         FlashWriteError = FlashStatus & 0x04;
090
091
092         CMD_STATE = READY;
093         mask_cnt = 0;
094         APP_MOTOR0.TargetSpeed = 0;
095
096         //FlashWriteFlag = 1;
097         BrownOut_Flag = 0;
098         CmdUpdate_Flag = 0;
099         FlashWrite_Flag = 0;
100         FaultClearCount = 0;
101
102         APP_MOTOR0.FaultClear = CMD_FAULT_CLEAR;
103         //if(FlashEmpty || FlashInvalid || FlashWriteError)
104         if((Power_state !=1) && (Power_state !=0))
105         {
106             Power_state = POWER_OFF;
107             Speed_state = TARGET_SPEED_1;
108             Power_Previous = POWER_OFF;
109             Speed_Previous = TARGET_SPEED_1;
```

## Appendices

## Code Listing 3 Script task1

```

110         }
111     }
112     /*****
113     *****/
114     /*Task1 function*/
115     Script_Task1()
116     {
117         if (APP_MOTOR0.SwFaults)
118         {
119             if (FaultClearCount < 5)
120             {
121                 APP_MOTOR0.FaultClear = CMD_FAULT_CLEAR;
122                 FaultClearCount = FaultClearCount + 1;
123             }
124         }
125         else
126         {
127             FaultClearCount = 0;
128
129             //FlashStorageDataValid = 0;
130             //IR_status = IR_GetStatus();
131             IR_status = IR_RxReceived();
132             Repeating = IR_RxRepeating();
133             //DataValid = (IR_status >> 4) & 0x00000001;
134             // DataValid bit
135
136         }
137
138         if (CMD_STATE == MASK)
139         {
140             mask_cnt = mask_cnt + 1;
141             if (mask_cnt == MASK_TIME_OUT)
142             {
143                 CMD_STATE = READY;
144                 mask_cnt = 0;
145             }
146
147             /* Received Data valid */
148             //if((DataValid || Repeating) && (CMD_STATE == READY))
149             if (IR_status || Repeating)
150             {
151                 command = IR_RxCommand();
152                 if (CMD_STATE == READY)
153                 {
154                     if (command == CMD_ON_OFF)
155                     {
156                         if (Power_state == POWER_OFF)
157                         {
158                             Power_state = POWER_ON;
159                         }
160                     }
161                     else
162                     {
163                         Power_state = POWER_OFF;
164                     }
165                 }
166             }
167         }
168     }
169 }

```

## Appendices

## Code Listing 3 Script task1

```

162         }
163     }
164     if(Power_state == POWER_ON)
165     {
166         if(command == CMD_SPEED_1)
167         {
168             Speed_state = TARGET_SPEED_1;
169         }
170         if(command == CMD_SPEED_2)
171         {
172             Speed_state = TARGET_SPEED_2;
173         }
174         if(command == CMD_SPEED_3)
175         {
176             Speed_state = TARGET_SPEED_3;
177         }
178         if(command == CMD_SPEED_4)
179         {
180             Speed_state = TARGET_SPEED_4;
181         }
182         if(command == CMD_SPEED_5)
183         {
184             Speed_state = TARGET_SPEED_5;
185         }
186     }
187
188     CMD_STATE = MASK;
189 }
190
191 if((Power_Previous != Power_state) || (Speed_Previous!=
Speed_state))
192 {
193     CmdUpdate_Flag = 1;
194 }
195 else
196 {
197     CmdUpdate_Flag = 0;
198 }
199 if(CmdUpdate_Flag)
200 {
201     FlashWrite_Flag = 1;
202 }
203
204 Power_Previous = Power_state;
205 Speed_Previous = Speed_state;
206 /*
207 APP_MOTOR0.Command = Power_state;
208 APP_MOTOR0.TargetSpeed = Speed_state;
209 */
210 if(FB_MEASURE.VdcFilt <= VDC_THRESHOLD )
    //VDC_THRESHOLD
211 {
212     //BrownOut_Flag = 1;
213

```

## Appendices

## Code Listing 3 Script task1

```

214         DCnormal_count = 0;
215         DCabnormal_count = DCabnormal_count + 1 ;
216         if(DCabnormal_count >= DC_Time_Out)
217         {
218             DCabnormal_count = 0;
219             BrownOut_Flag = 1;
220         }
221
222     }
223
224     if(FB_MEASURE.VdcFilt >= (VDC_THRESHOLD +
VDC_Hysteresis))
225     {
226         DCabnormal_count = 0;
227         DCnormal_count = DCnormal_count + 1 ;
228         if(DCnormal_count >= DC_Time_Out)
229         {
230             DCnormal_count = 0;
231             BrownOut_Flag = 0;
232         }
233     }
234
235     if(BrownOut_Flag)
236     {
237         APP_MOTOR0.Command = POWER_OFF;
238     }
239     else
240     {
241         APP_MOTOR0.Command = Power_state;
242         APP_MOTOR0.TargetSpeed = Speed_state;
243     }
244
245     if(BrownOut_Flag && ((MCEOS.Motor_SequencerState ==
STOP_State) || (MCEOS.Motor_SequencerState == FAULT_State)))
246     //if(BrownOut_Flag)
247     {
248
249         if(FlashWrite_Flag)
250         {
251             //FlashStorageDataValid = 1; //How to ensure
store successful this time?
252             Flash_Write();
253             FlashWrite_Flag = 0;
254
255         }
256     }
}

```

Appendices

Script	
#SCRIPT_START_COMMAND	3
#SCRIPT_TASK0_EXECUTION_PERIOD (ms)	50
#SCRIPT_TASK0_EXECUTION_STEP	60
#SCRIPT_TASK1_EXECUTION_PERIOD (10 ms)	5
#SCRIPT_TASK1_EXECUTION_STEP	70
#SCRIPT_USER_VERSION	1.0

Figure 37 Task execution timing configuration of the script

## 10 References

- [1] Infineon Technologies AG. Datasheet of ICL8810 (2021) Rev 1.0
- [2] Infineon Technologies AG. Design guide of ICL8810 DG\_2103\_PL39\_2104\_160011 (2021) V 1.0
- [3] Infineon Technologies AG. Engineering report of demo board with ICL8810 ER\_2103\_PL21\_2103\_001942 (2021) V 1.0
- [4] Infineon Technologies AG. Lightning surge discharge design for SMPS applications AN\_2006\_PL52\_2009\_103328 (2020) V 1.0
- [5] Infineon Technologies AG. Datasheet of IMD111T-6F040 (2020) V1.0
- [6] Infineon Technologies AG. Datasheet of IPA80R1K4P7 (2020) Rev2.2
- [7] Infineon Technologies AG. Datasheet of IRLML0040 (2012)
- [8] Infineon Technologies AG. Datasheet of BAS3005A (2008)
- [9] Infineon Technologies AG. Getting Started with iMOTION™ Solution Designer
- [10] Infineon Technologies AG. iMOTION™ Motion Control Engine Software Reference Manual (2021) V1.34
- [11] Infineon Technologies AG. Datasheet of 2ED2106S06F (2019) V2.10
- [12] Infineon Technologies AG. AN2023-03\_Infrared Remote Control and Saving Last Speed Setting



## Revision history

<b>Document version</b>	<b>Date</b>	<b>Description of changes</b>
V 1.0	28 Sep 2023	Initial version

**Trademarks**

All referenced product or service names and trademarks are the property of their respective owners.

**Edition 2023-09-28**

**Published by**

**Infineon Technologies AG**

**81726 Munich, Germany**

**© 2023 Infineon Technologies AG.**

**All Rights Reserved.**

**Do you have a question about this document?**

**Email: [erratum@infineon.com](mailto:erratum@infineon.com)**

**Document reference**

**UG-2022-05**

**WARNINGS**

Due to technical requirements products may contain dangerous substances. For information on the types in question please contact your nearest Infineon Technologies office.

Except as otherwise explicitly approved by Infineon Technologies in a written document signed by authorized representatives of Infineon Technologies, Infineon Technologies' products may not be used in any applications where a failure of the product or any consequences of the use thereof can reasonably be expected to result in personal injury.