

The PhotoVoltaic Relay: A New Solid State Control Device

by Bill Collins

Summary

Recent developments in semiconductor technology have led to the design of a new type of solid state relay which combines photovoltaic isolation with MOSFET power integrated circuit techniques. The International Rectifier PhotoVoltaic Relay brings solid state advantages to applications which previously could be served only by signal level electromechanical relays.

Introduction

Historically the relay is the earliest applied electrical device, preceding in relay telegraph usage the electrical motor and the incandescent lamp. The relay function of switching a load circuit with a low power, electrically isolated control circuit has been implemented by several basic design approaches. Figure 1 illustrates the relay topologies in both mechanical and solid state form which probably have been of greatest commercial significance.

The PhotoVoltaic Relay

A new topology, termed the PhotoVoltaic Relay (PVR), has recently evolved and is illustrated in Figure 2. The PVR topology achieves electro-optical isolation by means of a light emitting diode (LED) energizing a photovoltaic generator (PVG) consisting of a series connection of silicon PN junctions. The signal from the photovoltaic generator in turn activates a bidirectional MOSFET configuration.

The PVR circuit configuration achieves a unique combination of operating advantages not present in any of the topologies of Figure 1. The PVR

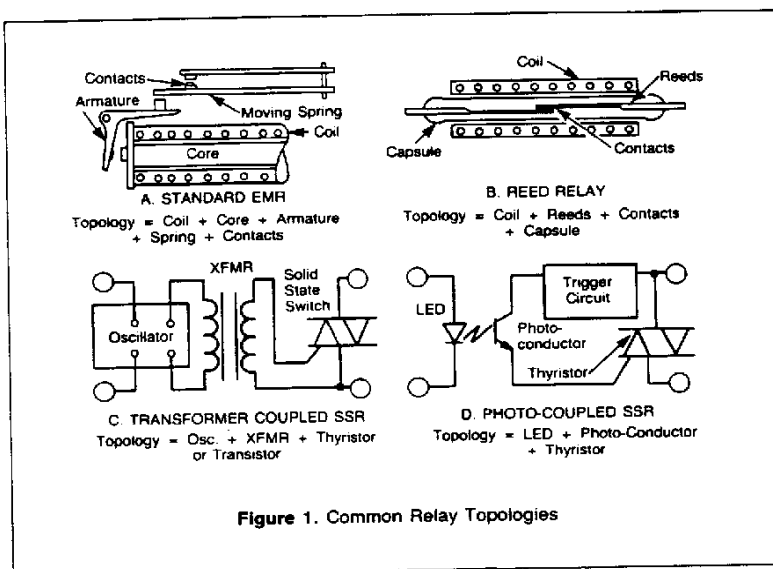

Figure 1. Common Relay Topologies

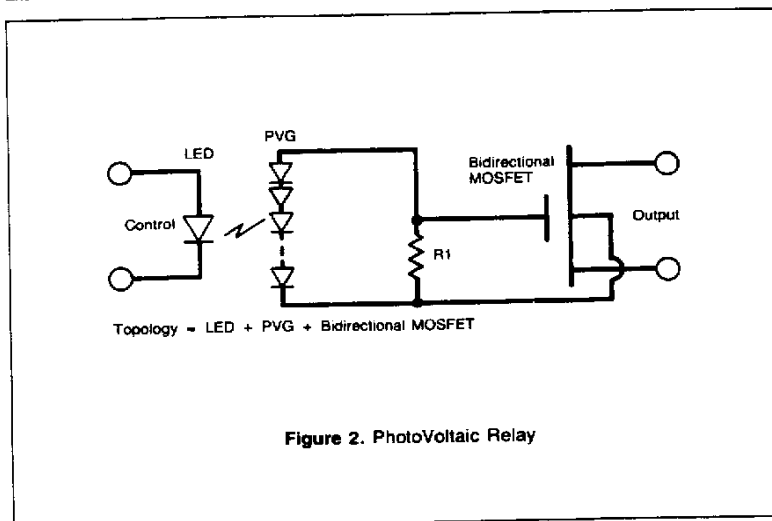

Figure 2. PhotoVoltaic Relay

This application note is a reprint of a paper presented by H. William Collins at the National Association of Relay Manufacturers (NARM), April 24, 1985.

has the solid state advantages of long switching life, high operating speed, low pick-up power, bounce-free operation, non-inductive input, insensitivity to position and magnetic fields, extreme shock and vibration resistance, and miniaturization. In addition, modern MOSFET technology provides a much better analog of an ideal electro-mechanical switch than does thyristor or bipolar transistor technology used dominantly as the output contacts in previous solid state relays (SSRs). Relative to thyristors, the MOSFET displays a linear on-resistance rather than an 0.6 volt threshold in forward conduction, as shown in Figure 3. An inverse series connection of two MOSFETs can switch DC or AC at frequencies well into the RF range. Static and commutating dv/dt effects are not inherent and turn off can be instantaneous. Relative to bipolar transistors, MOSFETs display lower on-state offset voltages, much lower off-state leakages, and, most importantly, have essentially infinite static forward current gain (i.e., MOSFETs are voltage controlled).

However, MOSFET technology inherently requires a larger area of silicon for a given volt-ampere power capability than does thyristor technology. Therefore, there is a severe economic limitation in using MOSFET devices in high power AC control applications where operational characteristics of thyristors are adequate. As such, PVRs supplement thyristor output SSRs in applications requiring fast switching of signals from microvolts to several hundred volts of either DC polarity or AC through the radio frequency range. These applications have commonly been served by reed capsule relays. International Rectifier's PVR now provides a functional equivalent of the reed relay and the advantages of solid state implementation.

PhotoVoltaic Isolation

Photo-isolated thyristor and bipolar transistor type SSRs use photo-conductive type isolators as shown in Figure 4A. These photo-isolators (also termed photo-couplers) receive optical radiation from a dielectrically isolated LED. This radiation modulates the conductivity of the photo receptor which can be a resistor (cadmium sulphide cell), a diode, transistor, Darlington transistor, or thyristor. The increased conductivity allows a current to flow from a separate voltage source thereby producing an output signal in a load such as R_L . In a 4-terminal SSR the supply voltage can be taken from the output terminals with the advantage of eliminating a separate power source. This simplification has the disadvantages of requiring a finite voltage drop across

the terminals before turn on, increasing the off-state leakage, and providing a possible path for load transients to feed through to the sensitive input of the SSR circuitry and cause malfunction.

The isolator technique shown in Figure 4B uses a series connection of photo diodes as a photo-receptor to form an isolated photovoltaic generator. This type of isolator actually transforms energy across the isolation barrier and creates an isolated voltage source. As such, a separate power source is not required to achieve an output signal or the attendant problems of deriving the turn-on signal from the SSR load terminals are eliminated.

Although a photovoltaic isolation technique may seem like an ideal circuit solution, until recently there have been severe practical problems in using

a photovoltaic isolator. An economically affordable and sufficiently compact photovoltaic generator produces only a weak output. A practical photovoltaic generator can generate several volts into an open circuit load, but only microamperes of output current.

However, the output of such a photovoltaic generator is an ideal match to the drive characteristics of a MOSFET. A modern power MOSFET requires several volts of signal for full conduction, but requires essentially zero steady state current. Only transient energy to charge the gate capacitance is required to turn on and then hold the MOSFET in conduction. A charging current of only a few microamperes can turn on a typical MOSFET in a small fraction of a millisecond — a fast response relative to electromechanical switching times.

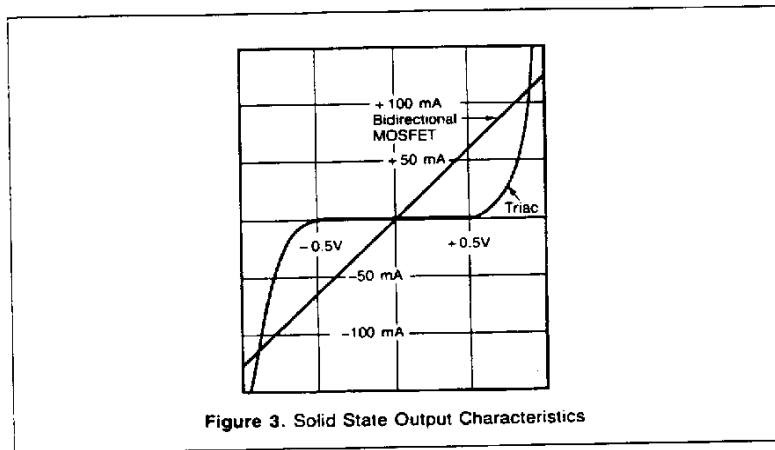

Figure 3. Solid State Output Characteristics

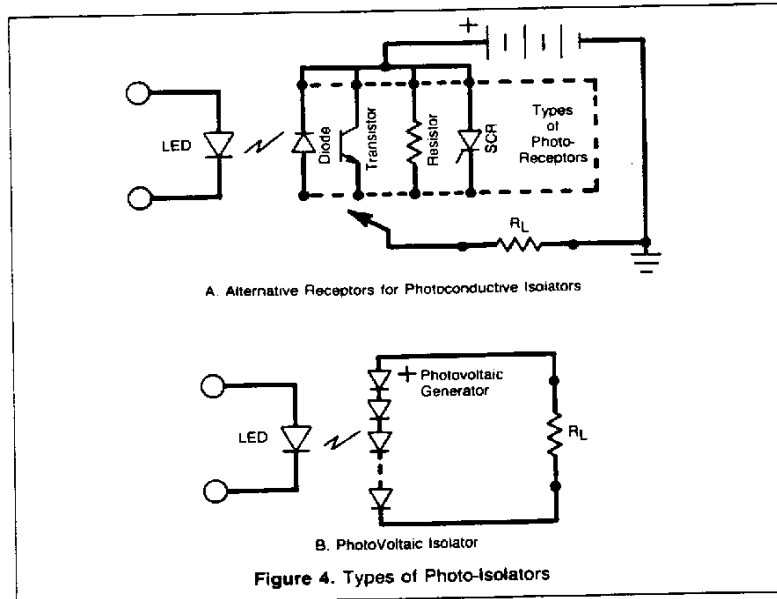

Figure 4. Types of Photo-Isolators

The PVR topology has become practical because of the perfection in the last five years of power MOSFET technology. It seems impractical to use a photovoltaic generator other than in conjunction with a MOSFET gate. Thyristors and bipolar transistors both require too much drive current. Hence, the term PhotoVoltaic Relay describes not only the isolation technique but also strongly implies a circuit topology with a MOSFET output.

MOSFET Output

Figure 2 shows a bidirectional MOSFET output that can be formed by use of two N-channel MOSFETs in inverse series, common source connection. The common source connection allows control by a single photovoltaic generator. For reliable and fast turn-off to occur, this configuration must provide a discharge path for the gate-to-source capacitance such as provided by resistor R_1 . Discharge will not occur effectively back through the photovoltaic generator because of the approximately 0.6 volt threshold conduction level per junction in the series connection of typically 10 to 20 diodes. A discharge resistor value in the 1 to 10 megohm range is desirable to prevent significant loading on the photovoltaic generator. The gate capacitance values of MOSFETs appropriate for a PVR can be in the 100 to 1000 picoFarad range, thereby producing discharge time constants in the millisecond range.

The release time of a PVR can be greatly decreased by the use of additional, active circuit elements. Circuitry using a depletion mode MOSFET normally shorted across the output MOSFET gate and turned off by a second photovoltaic generator has been previously described. An alternative method of fast gate discharge is shown in Figure 5.

Whenever the gate voltage of Q_1 is significantly more positive than the photovoltaic generator voltage, signifying that output transistor Q_1 should be turning off, enhancement mode P-channel transistor Q_2 (or a PNP bipolar) shorts the charge on the Q_1 gate to the source and accomplishes fast turn off. This circuit configuration has the advantage that only a single photovoltaic generator is required.

Using dynamic gate turn-off techniques, drop-out release times in the 10 to 50 microsecond range are easily achievable. MOSFETs switch in a bounce-free manner thereby minimizing circuit noise and eliminating settling times which can increase total switching times.

The extreme switching life possible with a MOSFET output arises because a transistor, operated at moderate temperature, does not experience any deterioration mechanism as a result of the switching action of its "contact" structure. The most common failure mechanism of power semiconductors results from self-heating temperature excursions from the on-off action which can cause mechanical failure of die bonds and wire bonds. Therefore, in PVR applications where on-off thermal stresses are slight, claims of near infinite switching life are justifiable.

The major weaknesses of a MOSFET output relative to metallic contacts are the closed circuit on-resistance and the open circuit capacitance. Compared to typically a closed resistance of 100 milliohms for signal level metallic contacts, a MOSFET on-resistance can be typically several ohms. Compared to an open circuit capacitance of typically one picoFarad, a MOSFET open circuit capacitance can be typically tens of picoFarads.

Both of these parameters are under the control of the semiconductor designer within the ultimate limits of the physics of the device structure. On-resistance can be decreased by increasing silicon chip area within economic limits. The on-resistance of a MOSFET varies typically at a rate greater than the square of the design blocking voltage. Therefore, on-resistance is greatly reduced by designing the chip structure for the minimum required blocking voltage. The modern power MOSFET has resulted because of great design advances made in reducing the on-resistance for a given blocking voltage while utilizing a given silicon area. Progress in this developmental area is continuing.

Design factors which tend to decrease on-resistance (such as increased area) also tend to increase off-state capacitance. At a given blocking voltage a figure of merit corresponding to the multiple of $R_{D(on)}$ times $C_{(off-state)}$ results. The ingenuity of the chip designer can minimize this number within limits, but often at the sacrifice of some other parameter such as transconductance. It follows that a full range of PVR designs will have MOSFET outputs of different blocking voltages and different chip areas thereby optimizing the interrelated on-resistance and off-state capacitance for a specific application.

Methods of PVR Implementation

The design challenge in making a practical PVR has been to implement the previously discussed concepts in a high performance, yet compact and economical manner. A discrete component approach cannot achieve either the miniaturization or cost which would allow the PVR to be directly competitive with alternative electromechanical relays. Hybrid circuit techniques, which place MOSFET and other chips on a ceramic substrate, move toward this ultimate goal. However, realization of truly competitive PVR has required innovative semiconductor processing, packaging, and advanced power integrated circuit techniques.

Both the photovoltaic generator and the bidirectional MOSFET output can be implemented by the integrated circuit technique of dielectric isolation. Dielectric isolation consists of etching grooves into a wafer of single crystal silicon, forming an insulating silicon dioxide layer over the etched wafer, and then epitaxially growing a thick layer of polysilicon to serve as the ultimate

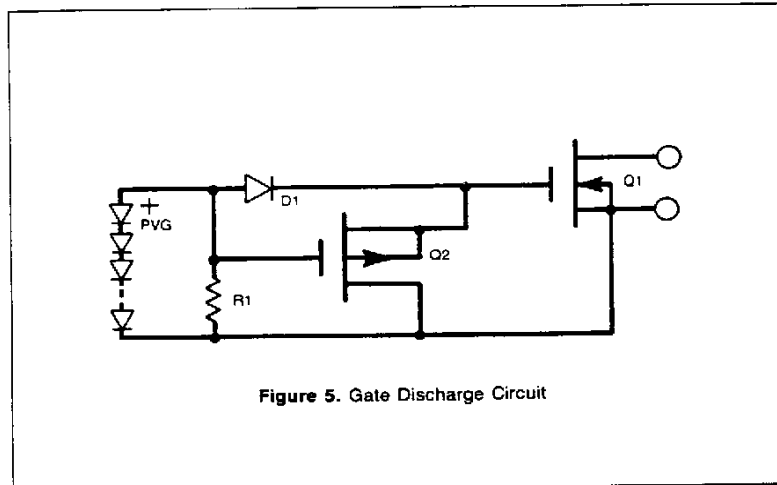

Figure 5. Gate Discharge Circuit

physical substrate. The wafer is then inverted and the original single crystal substrate ground away until oxide insulated "tubs" are exposed. Conventional diffusion techniques can then proceed to form semiconductor components. Although dielectric isolation requires relatively little semiconductor component design innovation, it is a complex and costly wafer manufacturing process. It also places some performance limitation such as lower current conversion efficiency of the photovoltaic generator, blocking voltage problems arising from surface metallic interconnects overlaying the blocking junctions, and optically induced offset voltages in a totally monolithic chip.

Photovoltaic Generator

A high performance, compact and economical series connection of photo diodes forming a photovoltaic generator is illustrated in Figure 6.

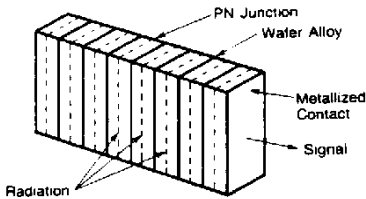

Figure 6. Edge Illuminated Photovoltaic Generator

This device is adapted from a standard manufacturing process for high voltage diode cartridges. PN junctions are diffused into individual silicon wafers. The wafers are then stacked and alloyed together. The wafer stack is then cut by a deep cut dicing saw into individual generators of the desired size. The wafer diffusion, of course, is designed for optimum photovoltaic generation rather than the requirements of a high voltage blocking diode.

This manufacturing process has great flexibility in varying both the number of diodes and the cross-sectional geometry. High conversion efficiency also results. The output signal is taken axially. This edge illuminated configuration does not require surface interconnect metallization which can block incident radiation. Also, all of the silicon is active in receiving radiation because there is no "dead" polycrystalline silicon area nor silicon dioxide required to isolate the individual PN junctions as with dielectric isolation.

Figure 7 shows the output characteristics of an edge illuminated photovoltaic isolator. This isolator

utilizes a gallium aluminum arsenide LED in a reflective cavity filled with a solid dielectric and achieves over 4000 volts RMS isolation.

Power IC MOSFET Output

Development has recently been completed on a novel power integrated circuit for a PVR termed a BOSFET[®] (Bidirectional Output Switch Field Effect Transistor). This monolithic chip contains a bidirectional MOSFET structure, fast turn-off circuitry and supplementary gate protection. The power IC techniques of the BOSFET make a compact and economical PVR a commercial reality. Figure 8 is a photograph of the BOSFET chip.

The BOSFET uses a unique high voltage process similar to N-well CMOS. This process integrates high voltage lateral DMOS transistors with a variety of low voltage control components. The BOSFET contains n-channel and p-channel MOS transistors, high gain NPN transistors, blocking diodes, zener diodes, high valued resistors, and capacitors.

The output transistors of the BOSFET use a self-aligned polysilicon gate technique to achieve the benefits of a short channel, a well controlled threshold, and a highly reliable gate-oxide interface. The process enables a single polysilicon layer to perform multiple functions. In addition to controlling the output devices, this selectively doped polysilicon layer is used for low resistance interconnects, high value isolated resistors, voltage independent high value capacitors, and P-channel and N-channel gates. The BOSFET is derived from modern power MOSFET technology and is an excellent example of a monolithic power IC formed by conventional IC manufacturing processes.

The BOSFET chip of Figure 8 blocks ± 300 volts peak and has 24 ohms maximum on-resistance at 25°C. Other voltage and on-resistance ratings can be designed by properly adapting the basic BOSFET structure. A BOSFET optimized for a PVR should combine high transconductance, low threshold voltage, low junction capacitances, and

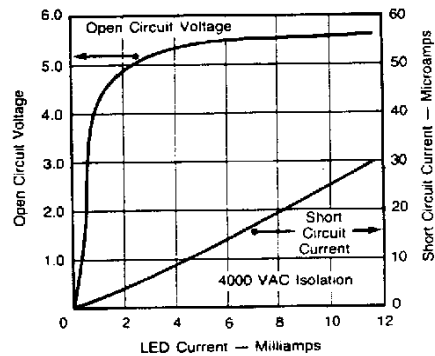

Figure 7. Output of 12 Cell Edge Illuminated PhotoVoltaic Isolator

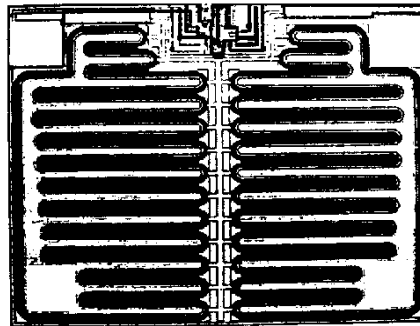

Figure 8. BOSFET Chip

high off-state resistance. Figure 9 shows a BOSFET transfer curve.

The variation of off-state resistance with applied voltage and temperature of a typical BOSFET is shown in Figure 10.

Operational Characteristics of a PVR

Figures 11 and 12 show a commercial PVR which is formed using a BOSFET chip and an edge illuminated photovoltaic isolator.

The PVR is a normally open, single pole configuration rated at 150 milliamperes continuous current and 300 volts peak blocking. The

mechanical structure is highly adaptable to high volume semiconductor assembly processes, using transfer molding to form both the inner reflective cavity and the outer housing. Figure 13 summarizes the performance characteristics of this PVR.

The clean switching characteristics and response times of the complete PVR are shown in Figures 14 and 15.

current for turn-on, even faster actuation can be achieved by applying an initial pulse which is then reduced to a much lower quiescent holding current. Figure 16 shows an input speed-up circuit which applies a 90 milliamperere overdrive pulse with approximately a 40 microsecond decay time constant,

thereby achieving a 25 microsecond actuation time. The quiescent current of 5 milliamperes which is maintained would result in a 150 microsecond actuation time without the speed-up circuit.

Release time is determined by circuit element values within the BOSFET and is largely independent of the input drive conditions.

The PVR inherently generates very low thermal voltages. This advantage arises because of the simplicity and ease of symmetry of the output structure. Even more important is the low control power generated in the package. A PVR requires only 3 milliwatts dissipation in the LED in a thermocouple switching

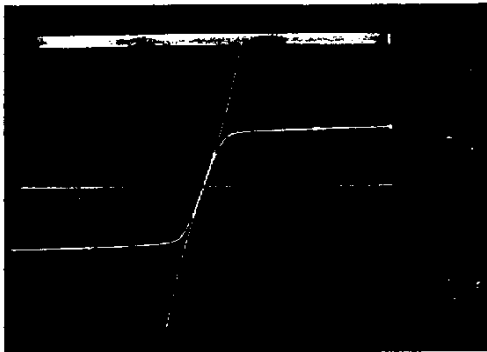

Figure 9. BOSFET Transfer Characteristics Output with 1 Volt, 2 Volt, and 3 Volt Gate Steps

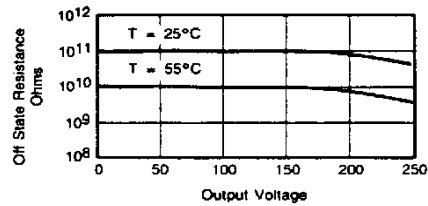

Figure 10. Typical BOSFET Off-State Resistance



Figure 11. Photograph of Single Pole PVR

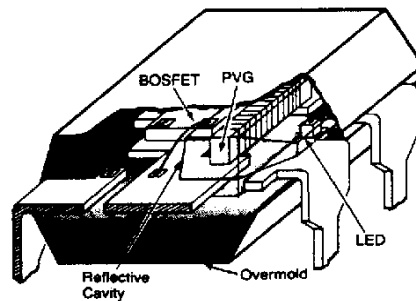

Figure 12. PVR Internal View

Typical PVR Operating Characteristics

Blocking Voltage:	± 300V
Current Rating:	130 mA @ 40°C
On Resistance:	20 ohms @ 25°C
Off Resistance:	10 ¹¹ ohms @ 25°C
Output Capacitance:	12 pf @ 50 VDC
Pick-up Current:	2 mA Light Load 10 mA Full Load
Response Time:	100 μSec @ 8 mA Drive
Thermal Offset:	200 nanovolts
Pick-up Power:	2 to 20 milliwatts
Switching Operations:	10 ¹⁰ @ 20 mA
Isolation:	2500 V(RMS)
Size:	0.5 in. x 0.3 in. x 0.2 in.

Figure 13. Operating Characteristics

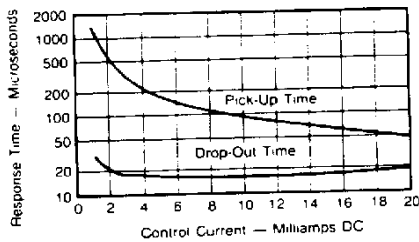

Figure 15. PVR Response Time

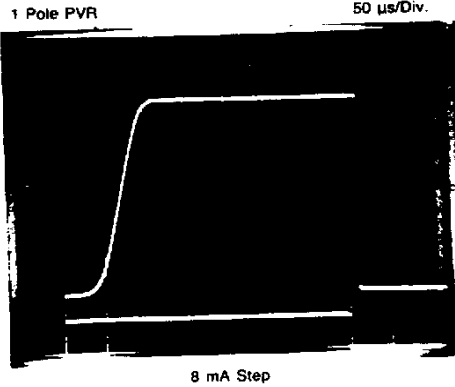

Figure 14. PVR Switching Action
Sweep = 50 μs/Div.
Signal = 8 mA Step
Upper Trace = Output Closure

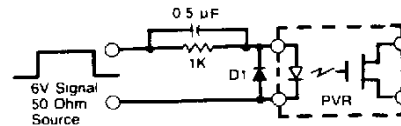

Figure 16. Fast Turn-On Circuit

application versus 50 milliwatts minimum coil power for an electromechanical relay. As a result, a PVR can readily be produced to a 200 nanovolt maximum thermal offset specification.

The output switching life of a PVR is easily demonstrated. A test was recently completed where a group of 10 PVRs were operated for 10¹⁰ switching cycles without failure or significant deterioration of the BOSFET outputs.

The test was conducted by switching 20 milliamperes from a 50 volt DC source with 50% duty cycle at a 1 kHz rate. The 10¹⁰ switching operations life point is reached in about 116 days.

Conclusion

The International Rectifier PhotoVoltaic Relay can achieve previously unattainable switching life, operating speed, control power sensitivity, low thermal voltage generation, and miniaturization. These characteris-

tics are increasingly needed by designers for process control, data acquisition, multiplexing, automatic test equipment, and telecommunications equipment. The new PVR topology will allow the venerable relay function to meet these ongoing challenges. □