

## Product Brief

# TLE9202ED

## Dual general purpose 6 A H-bridge with SPI diagnosis

TLE9202ED is a dual general purpose 6 A H-bridge for industrial and automotive applications, designed for the control of small DC motors and inductive loads. It meets the harsh automotive environmental conditions and it is qualified in accordance with the AEC-Q100 standard.

The outputs can be pulse width modulated at frequencies up to 20 kHz by means of PWM/DIR control. While the signal at the direction input defines the direction of the DC motor, the PWM signal controls the duty cycle. PWM/DIR control reduces the number of PWM capable pins needed at the microcontroller.

For load currents above the current limitation threshold (8 A typ.) the H-bridge switches into chopper current limitation mode. The TLE9202ED is protected against short circuits and overtemperature and provides diagnosis via SPI or basic error feedback via status flag. Open load can be detected when the bridge is disabled or during PWM operation of inductive loads.

The new robust dual inline DSO-36 (Dual gauge) package provides excellent thermal performance and is robust for harsh environments in automotive as well as industrial applications.

### Applications

- > Exhaust Gas Recirculation (EGR)
- > Variable Geometry Turbo (VGT)
- > Idle speed control
- > Swirl and tumble flaps
- > Variable intake manifold
- > Turbo charger waste gate
- > Auxiliary water pumps
- > Industrial DC motor applications

### Performance TLE9202ED

The TLE9202ED is based on TLE9201SG with two independent general purpose 6 A H-bridges in a robust and small package for PCB area optimization.

#### Key features

- >  $R_{DS(on)}$  (typ) < 100 m $\Omega$  per switch
- > Operation voltage: 5.0 V to 28 V
- > Fully 3.3/5.0 V compatible logic inputs
- > Low standby current
- > Short circuit and overtemperature protection
- >  $V_S$  undervoltage protection
- > Open load detection in On and Off state
- > Detailed SPI diagnosis or simple error flag
- > Qualified according automotive standard AEC-Q100
- > Green product (RoHS compliant)

#### Key benefits

- > Small package saves board space
- > Simple control with PWM/DIR control pins
- > Simple design with few external components
- > Optional SPI enables for easy diagnosis



# TLE9202ED

## Dual general purpose 6 A H-bridge with SPI diagnosis

### Block diagram

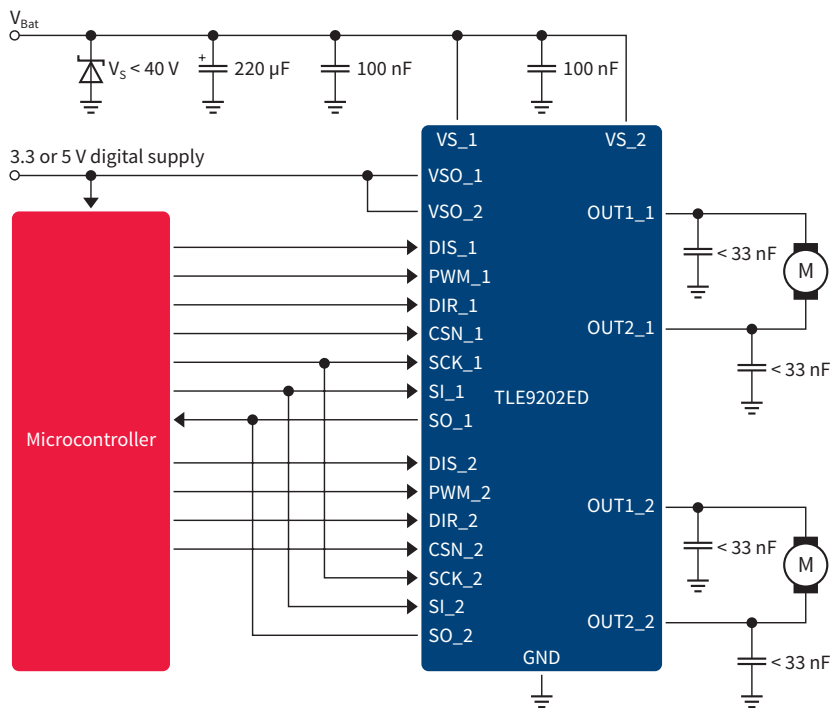

### The DSO-36 (Dual gauge) package

- > Small footprint (106 mm<sup>2</sup>)
  - > 0.5 mm pitch
  - > Unparalleled thermal performance
- $R_{thJC} < 1 \text{ K/W}$

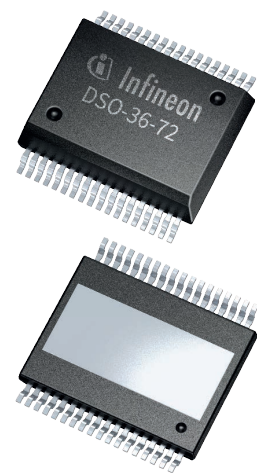

### Product summary

Product name	$R_{DS(on)} \text{ HS}$ [mΩ]	$R_{DS(on)} \text{ LS}$ [mΩ]	$I_{LM} \text{ min.}$ [A]	$I_Q \text{ max.}$ [mA]	$V_{S(OP)} \text{ [V]}$	Diagnostic IF	$V_{DD} \text{ mon.}$	Package
TLE5205-2G	220	220	6.00	10.00	6.00 ... 40.00	Status Flag		TO263-7-1 (TO220-7 (SMD))
TLE5206-2S	220	220	6.00	10.00	6.00 ... 40.00	Status Flag		TO220-7-12
TLE6209R	140	130	3.40 ... 5.95	0.05	5.20 ... 40.00	SPI		DSO-20 (Power-SO)
TLE7209-2R	150	150	5.50	20.00	5.00 ... 28.00	SPI and Status Flag		DSO-20 (Power-SO)
TLE7209-3R	150	150	5.50	20.00	5.00 ... 28.00	SPI and Status Flag		DSO-20 (Power-SO)
TLE8209-2SA	115	125	1.00 ... 7.70	0.02	4.50 ... 28.00	SPI and Status Flag	•	DSO-20 (Power-SO)
TLE8209-4SA	115	125	1.00 ... 9.00	0.02	4.50 ... 28.00	SPI and Status Flag	•	DSO-20 (Power-SO)
TLE9201SG	100	100	6.00	0.03	5.00 ... 28.00	SPI and Status Flag		DSO-12
TLE9202ED <sup>1)</sup>	100	100	6.00	0.03	5.00 ... 28.00	SPI and Status Flag		DSO-36 (Dual gauge)

1) Dual TLE9201 in one package

Published by  
Infineon Technologies AG  
81726 Munich, Germany

© 2016 Infineon Technologies AG.  
All Rights Reserved.

#### Please note!

THIS DOCUMENT IS FOR INFORMATION PURPOSES ONLY AND ANY INFORMATION GIVEN HEREIN SHALL IN NO EVENT BE REGARDED AS A WARRANTY, GUARANTEE OR DESCRIPTION OF ANY FUNCTIONALITY, CONDITIONS AND/OR QUALITY OF OUR PRODUCTS OR ANY SUITABILITY FOR A PARTICULAR PURPOSE. WITH REGARD TO THE TECHNICAL SPECIFICATIONS OF OUR PRODUCTS, WE KINDLY ASK YOU TO REFER TO THE RELEVANT PRODUCT DATA SHEETS PROVIDED BY US. OUR CUSTOMERS AND THEIR TECHNICAL DEPARTMENTS ARE REQUIRED TO EVALUATE THE SUITABILITY OF OUR PRODUCTS FOR THE INTENDED APPLICATION.

WE RESERVE THE RIGHT TO CHANGE THIS DOCUMENT AND/OR THE INFORMATION GIVEN HEREIN AT ANY TIME.

#### Additional information

For further information on technologies, our products, the application of our products, delivery terms and conditions and/or prices, please contact your nearest Infineon Technologies office ([www.infineon.com](http://www.infineon.com)).

#### Warnings

Due to technical requirements, our products may contain dangerous substances. For information on the types in question, please contact your nearest Infineon Technologies office.

Except as otherwise explicitly approved by us in a written document signed by authorized representatives of Infineon Technologies, our products may not be used in any life-endangering applications, including but not limited to medical, nuclear, military, life-critical or any other applications where a failure of the product or any consequences of the use thereof can result in personal injury.