

# TLE4927C

## Dynamic Differential Hall Effect Sensor



### Features

- High sensitivity single chip solution
- Symmetrical thresholds
- High resistance to Piezo effects
- South and north pole pre-induction possible
- Low cut-off frequency
- Digital output signal
- Advanced performance by dynamic self-calibration principle
- Two-wire and three-wire configuration possible
- Wide operating temperature range
- Fast start-up time
- Large operating air-gaps
- Reverse voltage protection at  $V_S$ -pin
- Short-circuit and over temperature protection of output
- Digital output signal (voltage interface)
- Module style package with two integrated capacitors:
  - 4.7nF between Q and GND
  - 47nF<sup>1</sup> between  $V_S$  and GND: Needed for micro cuts in power supply



### Potential applications

- Automotive Crankshaft applications and similar, industrial speed sensor applications

### Product validation

Qualified for Automotive Applications.  
Product Validation according to AEC-Q100/101

### Description

The differential Hall sensor IC detects the motion and position of ferromagnetic and permanent magnet structures by measuring the differential flux density of the magnetic field. To detect ferromagnetic objects the magnetic field must be provided by a back biasing permanent magnet (south or north pole of the magnet attached to the rear unmarked side of the IC package).

### Ordering Information

Type	Marking	Ordering Code	Package
TLE4927C E6547	27D8	SP000718266	PG-SSO-3-92

<sup>1</sup> value of capacitor: 47nF±10%; (excluded drift due to temperature and over lifetime); ceramic: X8R; maximum voltage: 50V.

## Functional Description

## General Information

The TLE4927C E6547 is an active Hall sensor suited to detect the motion and position of ferromagnetic and permanent magnet structures. An additional self-calibration module has been implemented to achieve optimum accuracy during normal running operation. It comes in a three-pin package for the supply voltage and an open drain output.

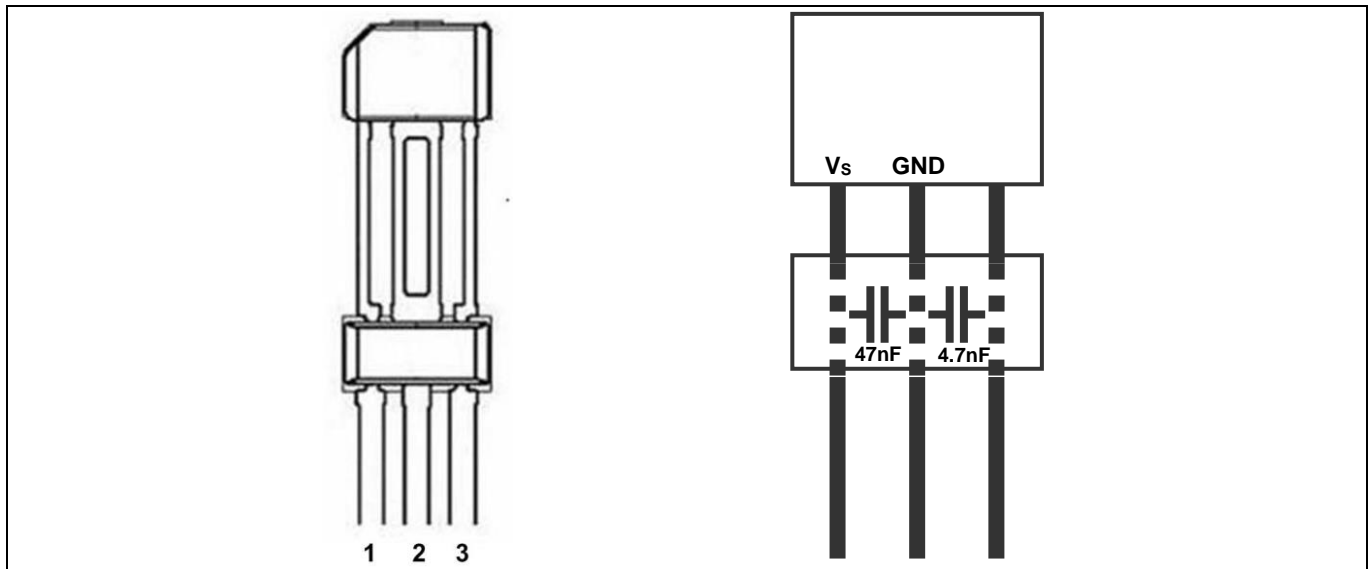

**Figure 1** Pin configuration PG-SSO-3-92

Pin No.	Symbol	Function
1	$V_s$	Supply Voltage
2	GND	Ground
3	Q	Open Dain Output

## Table of contents

<b>Features</b> .....	<b>1</b>
<b>Potential applications</b> .....	<b>1</b>
<b>Product validation</b> .....	<b>1</b>
<b>Description</b> .....	<b>1</b>
<b>General Information</b> .....	<b>2</b>
<b>Table of contents</b> .....	<b>3</b>
<b>1 Functional Description</b> .....	<b>4</b>
1.1 Circuit Description .....	4
1.1.1 Startup mode .....	4
1.1.2 Running mode .....	5
<b>2 General Characteristics</b> .....	<b>6</b>
2.1 Absolute Maximum Ratings .....	6
2.2 Operating Range .....	7
2.3 AC/DC Characteristics .....	8
2.4 Magnetic Characteristics in Running Mode .....	9
2.5 Typical Hysteresis Values .....	10
2.6 Self-calibration Characteristics .....	10
<b>3 Application Configurations</b> .....	<b>13</b>
3.1 Gear Tooth Sensing .....	13
<b>4 Electro Magnetic Compatibility</b> .....	<b>17</b>
<b>5 Package Information</b> .....	<b>19</b>
<b>Appendix:</b> .....	<b>21</b>
<b>Revision history</b> .....	<b>24</b>

# 1 Functional Description

The differential Hall sensor IC detects the motion and position of ferromagnetic and permanent magnet structures by measuring the differential flux density of the magnetic field. To detect ferromagnetic objects the magnetic field must be provided by a back biasing permanent magnet (south or north pole of the magnet attached to the rear unmarked side of the IC package).

Offset cancellation is achieved by advanced digital signal processing. Immediately after power-on motion is detected (start-up mode). After a few transitions the sensor has finished self-calibration and switches to a high-accuracy mode (running mode). In running mode switching occurs at signal zero-crossing of the arithmetic mean of max and min value of magnetic differential signal.  $\Delta B$  is defined as difference between hall plate 1 and hall plate 2.

## 1.1 Circuit Description

The TLE4927C E6547 is comprised of a supply voltage regulator, a pair of hall probes, spaced at 2.5mm, differential amplifier, noise-shaping filter, comparator, advanced digital signal processor (DSP), A/D and D/A converter and an open drain output.

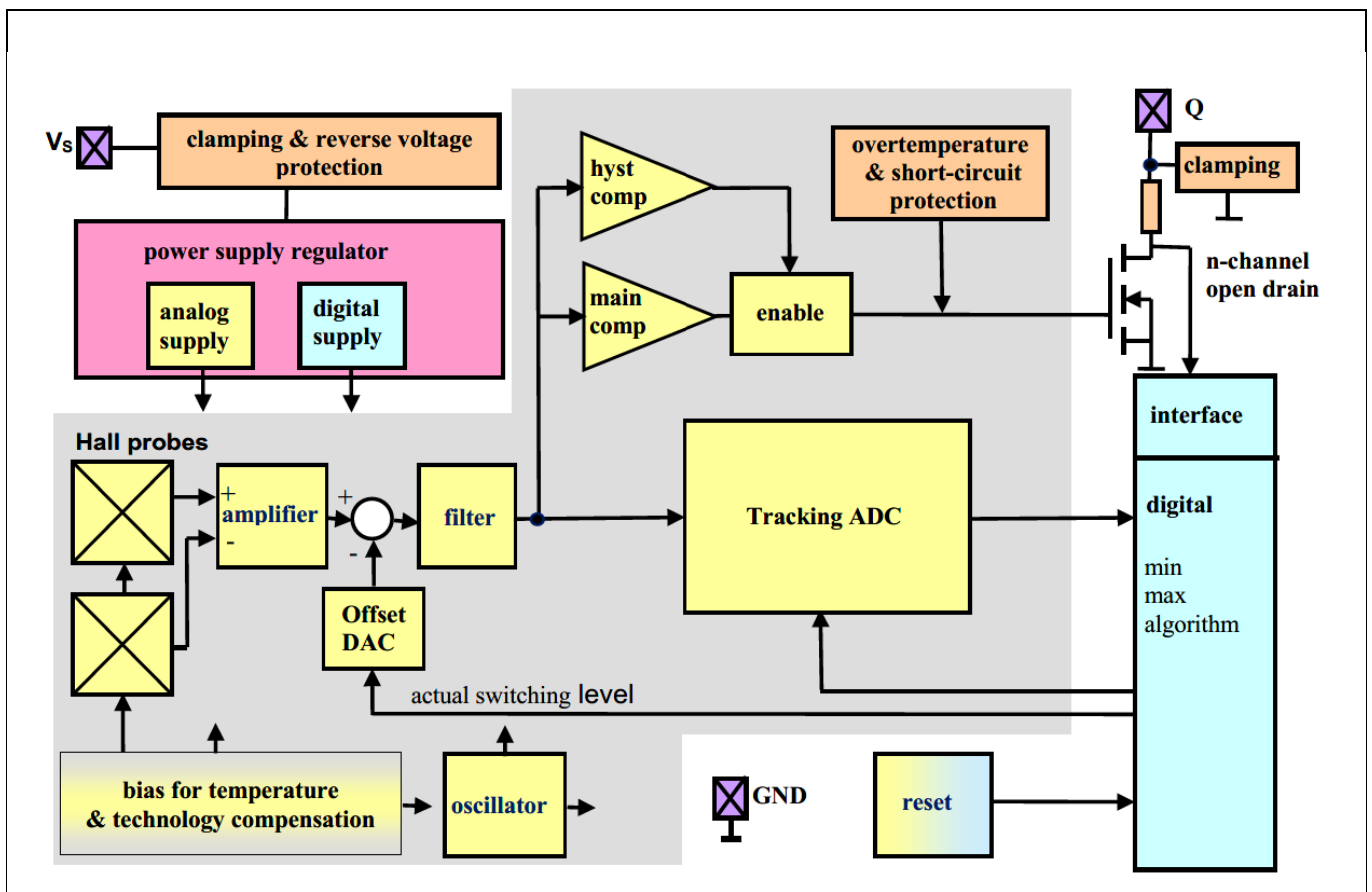

Figure 2 Block diagram of TLE4927C E6547

### 1.1.1 Startup mode

The differential signal is digitized in the A/D converter and fed into the DSP part of the circuit. There a rising or falling transition is detected and the output stage is triggered accordingly. As the signal is not offset compensated at this time, the output does not necessarily switch at zero-crossing of the magnetic signal. Signal peaks are also detected in the digital circuit and their arithmetic mean value can be calculated. The

Functional Description

offset of this mean value is determined and fed into the offset cancellation DAC. This procedure can be repeated with increasing accuracy. After few increments the IC is switched into the high accuracy running mode.

1.1.2 Running mode

In running mode, the output is triggered by the comparator. An offset cancellation feedback loop is formed by the A/D converter, DSP and offset cancellation D/A converter. In running mode switching always occurs at zero-crossing. It is only affected by the (small) remaining offset of the comparator and by the remaining propagation delay time of the signal path, mainly determined by the noise-shaping filter. Nevertheless, signals below a defined threshold are not detected to avoid unwanted parasitic switching.

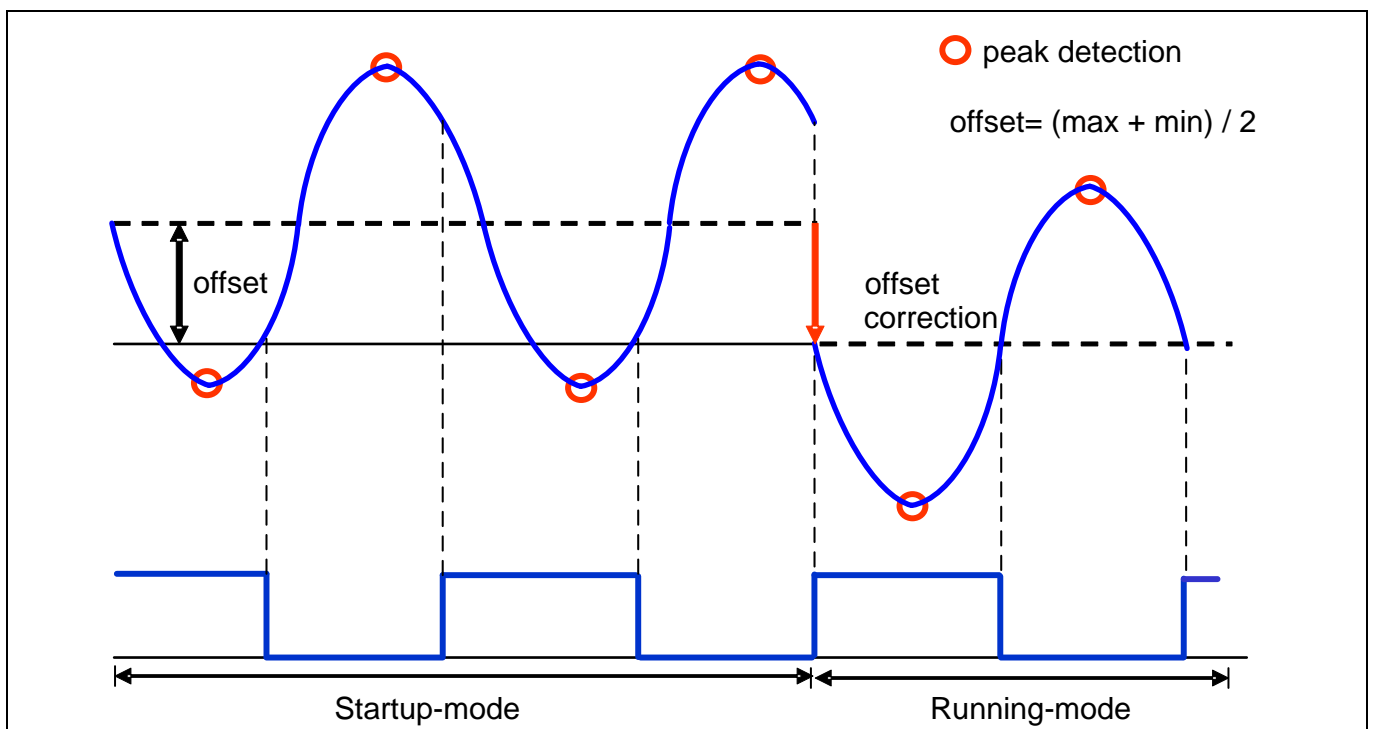

Figure 3 Startup of the device

At transition from startup-mode to running mode switching timing is moving from low-accuracy to high accuracy zero-crossing.

## 2 General Characteristics

### 2.1 Absolute Maximum Ratings

Parameter	Symbol	Values			Unit	Note or Test Condition
		Min.	Typ.	Max.		
Supply voltage	$V_S$	-18		18	V	-
		-24		24	V	1h with $R_{Series} \geq 200\Omega^2$
		-26		26	V	5min with $R_{Series} \geq 200\Omega^2$
		-28		28	V	1min with $R_{Series} \geq 200\Omega^2$
Supply current	$I_S$	-10		25	mA	-
Output OFF voltage	$V_Q$	-0.3		18	V	-
		-18		24	V	1h with $R_{Load} \geq 500\Omega$
		-18		26	V	5min with $R_{Load} \geq 500\Omega$
		-1.0		-	V	1h (protected by internal series resistor)
Output ON voltage	$V_Q$	-		16	V	Current internal limited by short circuit protection (72h @ $T_A < 40^\circ\text{C}$ ).
		-		18	V	Current internal limited by short circuit protection (1h @ $T_A < 40^\circ\text{C}$ ).
		-		24	V	Current internal limited by short circuit protection (1min @ $T_A < 40^\circ\text{C}$ ).
Continuous output current	$I_Q$	-50		50	mA	-
Junction temperature	$T_j$	-40			$^\circ\text{C}$	-
				155	$^\circ\text{C}$	2000h (not additive)
				165	$^\circ\text{C}$	1000h (not additive)
				175	$^\circ\text{C}$	168 h (not additive)
				195	$^\circ\text{C}$	3 x1 h (additive to the other life times).
Storage temperature	$T_S$	-40		150	$^\circ\text{C}$	-
Thermal resistance junction-air for PG-SSO-3-92	$R_{th,JA}$			190	K/W	Lower values are possible with overmoulded devices.
ESD-protection PG-SSO-3-92	$V_{ESD}$	$\pm 6$			kV	According to standard EIA/JESD22-A114-B Human Body Model (HBM 1500 Ohm/100pF)

<sup>2</sup> Accumulated life time.

## General Characteristics

Note: Stresses above those listed here may cause permanent damage to the device. Exposure to absolute maximum rating conditions for extended periods may affect device reliability.

## 2.2 Operating Range

Parameter	Symbol	Values			Unit	Note or Test Condition
		Min.	Typ.	Max.		
Supply voltage	$V_S$	3.2		18	V	Continuous
				24	V	1h with $R_{Series} \geq 200\Omega$
				26	V	5min with $R_{Series} \geq 200\Omega$ . Extended limits for parameters in characteristics.
		3			V	During test pulse 4. Limited performance possible
Supply voltage ripple	$V_{SAC}$			6	$V_{pp}$	$V_S=13V$ ; $0 < f < 50kHz$
Continuous output OFF voltage	$V_Q$	0		18	V	Continuous
		0		24	V	1h with $R_{Load} \geq 500\Omega$
Continuous output ON Current	$I_Q$	0		20	mA	$V_{Qmax}=0.6V$
Power on time	$t_{on}$			1.0	ms	Time to achieve specified accuracy. After power on the output of the IC is always in high-state. After internal resets output is locked <sup>3</sup> .
Operating junction temperature	$T_j$	-40			°C	-
				155	°C	2000 h (not additive)
				165	°C	1000 h (not additive)
				175	°C	168 h (not additive) reduced signal quality permissible (e.g. jitter)

Note: Unless otherwise noted, all temperatures refer to junction temperature. For the supply voltage lower than 28V ( $R_{Series} \geq 200\Omega$ ) and junction temperature lower than 195°C the magnetic and AC/DC characteristics can exceed the specification limits

<sup>3</sup> Output of the IC is locked in present state (high-state or low-state) after an internal reset is launched. This reset happens typically every 780ms when there is no output switching in either case. See also "Offset recalibration time after last output change,  $t_{reset}$ ". A voltage reset causes a release of the output and output is in high state after power on again.

## General Characteristics

## 2.3 AC/DC Characteristics

Parameter	Symbol	Values			Unit	Note or Test Condition
		Min.	Typ.	Max.		
Supply current	$I_S$	3	6.8	9	mA	-
Supply current @ 3.2V	$I_{S\_Vs\_min}$	3	6.7	8.5	mA	$V_S=3.2V$
Supply current @ 24V	$I_{S\_Vs\_max}$	3	7	9.5	mA	$V_S=24V, R_{Series} \geq 200\Omega$
Output saturation voltage	$V_{Qsat}$		0.25	0.6	V	$I_Q=20mA$
Output leakage current	$I_{Qleak}$		0.1	10	$\mu A$	$V_Q=18V$
Current limit for short-Circuit protection	$I_{Qshort}$	30	60	80	mA	-
Junction temperature limit for output protection	$T_{prot}$	195	210	230	$^{\circ}C$	-
Output rise time	$t_r^4$	4	12	20	$\mu s$	$V_{Load} = 4.5$ to $24V$ $R_{Load} = 1.2k\Omega$ ; $C_{Load} = 4.7nF$ included in package
Output fall time	$t_f^5$	0.5	0.9	1.3	$\mu s$	$V_{Load} = 5V$ $V_{Load} = 12V$ $R_{Load} = 1.2k\Omega$ ; $C_{Load} = 4.7nF$ included in package
		0.65	1.15	1.65	$\mu s$	
Delay time Falling edge Rising edge	$t_d$	7	12.5	18 <sup>6</sup>	$\mu s$	Only valid for $T_j=25^{\circ}C$ . $T_j=-40^{\circ}C - T_j=175^{\circ}C$ $T_j=-40^{\circ}C - T_j=175^{\circ}C$ Higher magnetic slopes and overshoots reduce $t_d$ , because the signal is filtered internal <sup>8</sup>
				20		
				25 <sup>7</sup>		
Temperature drift of delay time of output to magnetic edge	$\Delta t_d$	-6	3 <sup>9</sup>	6	$\mu s$	Time over specified temperature range; not additional to $t_d$
Frequency range	f	0.001		8	kHz	Operation below $1Hz^{10}$

<sup>4</sup> value of capacitor:  $4.7nF \pm 10\%$ ; (excluded drift due to temperature); ceramic: X8R; maximum voltage: 50V. The rise time is defined as the time between the 10 and 90% value.

<sup>5</sup> see footnote 4.

<sup>6</sup> only valid for the falling edge.

<sup>7</sup> Not subject to production test-verified by design/characterisation

<sup>8</sup> measured with a sinusoidal-field with  $10mT_{pp}$  and a frequency of 1kHz.

<sup>9</sup> related to  $T_j=175^{\circ}C$ .

<sup>10</sup> output will switch if magnetic signal is changing more than  $2x |\Delta B_{min}|$  within offset recalibration time even below 1Hz once per magnetic edge, increased phase error is possible



## General Characteristics

Parameter	Symbol	Values			Unit	Note or Test Condition
		Min.	Typ.	Max.		
Oscillator frequency	$f_{osc}$		1.34		MHz	-
Offset recalibration time after last output change	$t_{reset}$	625	780	970	ms	Output locked to state before recalibration
Clamping voltage $V_{S-pin}$	$V_{Sclamp}$	24	27.5		V	1 mA through clamping device
Clamping voltage Q-pin	$V_{Qclamp}$	24	27.5		V	1 mA through clamping device
Analog reset voltage	$V_{Sreset}$		2.35	2.9	V	-

Note: The listed AC/DC and magnetic characteristics are ensured over the operating range of the integrated circuit. Typical characteristics specify mean values expected over the production spread. If not other specified, typical characteristics apply at  $T_j = 25\text{ °C}$  and  $V_s = 12\text{ V}$

## 2.4 Magnetic Characteristics in Running Mode

Parameter	Symbol	Values			Unit	Note or Test Condition
		Min.	Typ.	Max.		
Bias preinduction	$B_0$	-500		500	mT	-
Differential bias induction	$\Delta B_0$	-30		30	mT	-
Minimum signal amplitude	$ \Delta B_{min} ^{11}$	0.35	0.75	1.35	mT	
Maximum signal amplitude	$ \Delta B_{max} $			100	mT	Additional to $B_0$ <sup>12</sup>
Resistivity against mechanical stress (piezo)	$ \Delta B_{min} $	-0.2		0.2	mT	F= 2N

Note: The listed characteristics are ensured over the operating range of the integrated circuit. Typical characteristics specify mean values expected over the production spread. If not otherwise specified, typical characteristics apply at  $T_j=25\text{ °C}$  and the given supply voltage.

<sup>11</sup>  $|\Delta B_{min}|$  refers to 50 % criteria: 50 % of output pulses are lost, sinusoidal input signal

<sup>12</sup> exceeding this limit might result in decreased duty cycle performance. With higher values the internal measured signal will be clipped. This will decrease the phase accuracy.

## General Characteristics

## 2.5 Typical Hysteresis Values

PGA	GainRange	Hysteresis (peak to peak)	FullRange =MaxSignal	Percentage thresholds
X1	6	10.6 mT	± 120 mT	4.42 %
X2	5	8.0 mT	± 60 mT	6.67 %
X4	4	5.5 mT	± 30 mT	9.17 %
X8	3	3.8 mT	± 15 mT	12.67 %
X16	2	2.6 mT	± 7.5 mT	17.33 %
X32	1	1.8 mT	± 3.75 mT	24 %
X64	0	1.3 mT	± 1.875 mT	34.67 %

## 2.6 Self-calibration Characteristics

Parameter	Symbol	Values			Unit	Note or Test Condition
		Min.	Typ.	Max.		
No. of magnetic edges for first output switching	n <sub>Start</sub>			2	-	latest 2 <sup>nd</sup> magnetic edge will cause output switching
No. of magnetic edges to enter calibrated mode	n <sub>Calib</sub>			6	-	Low phase accuracy permitted (see: uncalibrated phase error). 7 <sup>th</sup> edge with high accuracy. Valid for sinusoidal signal without noise influence
Duty cycle in running mode <sup>13</sup>	Dty	45	50	55	%	ΔB <sub>PP</sub> = 10mT ideal sinusoidal input signal (T <sub>j</sub> =25°C)
		40	50	60	%	ΔB <sub>PP</sub> = 10mT ideal sinusoidal input signal (-40°C ≤ T <sub>j</sub> < 175°C)
Signal jitter in running mode; 1 sigma value <sup>6</sup>	σ1		≤ ±0.11 <sup>14</sup>		%	ΔB <sub>PP</sub> = 10mT ideal sinusoidal input signal; T <sub>j</sub> <150°C
	σ2		≤ ±0.16		%	ΔB <sub>PP</sub> = 10mT ideal sinusoidal input signal; 150°C ≤ T <sub>j</sub> < 175°C
Signal Jitter in running mode at power supply of V <sub>S</sub> =13V and ripple ±3V; 1 sigma value <sup>6</sup>	σ3		≤ ±0.11		%	ΔB <sub>PP</sub> = 10mT ideal sinusoidal input signal; T <sub>j</sub> <150°C
	B <sub>neff</sub>		25		μT	T <sub>j</sub> = 25°C; The magnetic noise is normal distributed,

<sup>13</sup> this corresponds to a ΔB<sub>0</sub> = 0mT (magnetic offset).

<sup>14</sup> depends largely on |ΔB<sub>min</sub>| magnetic signal steepness and also on frequency.

General Characteristics

Parameter	Symbol	Values			Unit	Note or Test Condition
		Min.	Typ.	Max.		
Effective noise value of the magnetic switching points, 1 sigma value						nearly independent to frequency and without sampling noise or digital noise effects. The typical value represents the rms-value here and corresponds therefore to 1σ probability of normal distribution. Consequently a 3σ value corresponds to 0.3% probability of appearance.
				70	μT	The max value corresponds to the rms-values in the full temperature range and includes technological spreads.
Uncalibrated phase error: Magnetic edge 1-3 After 3 <sup>rd</sup> edge				≤ ±90 ≤ ±55	°	Related to calibrated switching behaviour. ΔB <sub>PP</sub> = 10mT ideal sinusoidal input signal <sup>15</sup> Magnetic fields close to 2x  ΔB <sub>min</sub>

<sup>15</sup> smaller phase errors are possible at higher signal amplitudes, because sinus signal changes to a more rectangle signal.

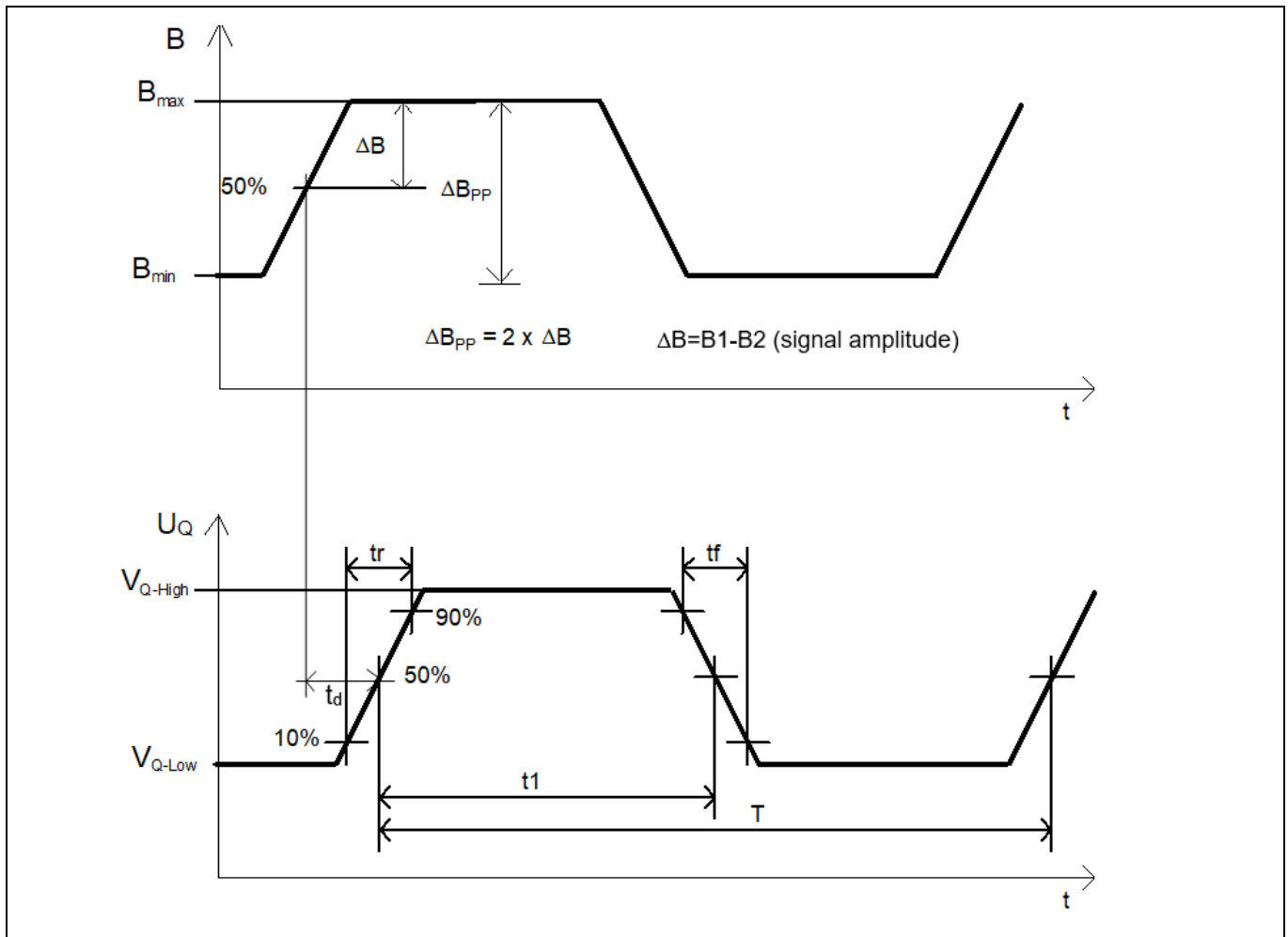

Figure 4 Switching direction

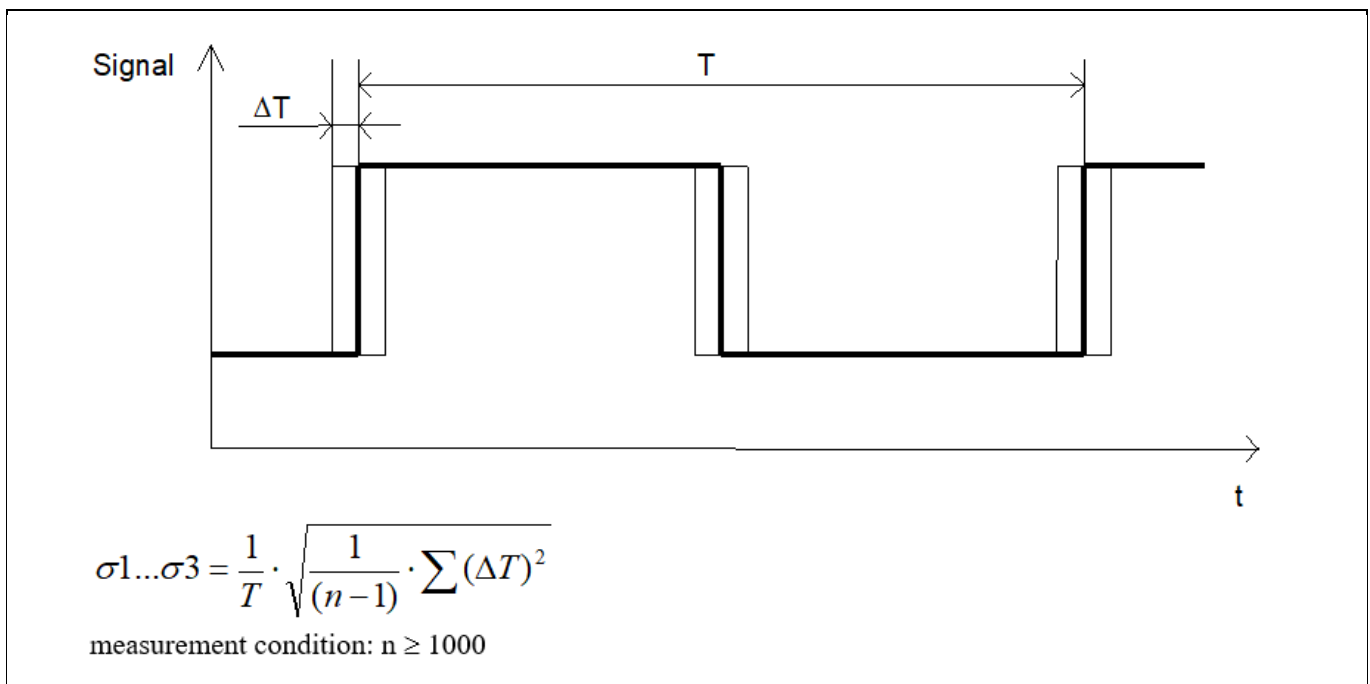

Figure 5 Definition of signal jitter

### 3 Application Configurations

Two possible applications are shown in Figure 8 and Figure 9 (Toothed and Magnet Wheel). The difference between two-wire and three-wire application is shown in Figure 10.

#### 3.1 Gear Tooth Sensing

In the case of ferromagnetic toothed wheel application, the IC has to be biased by the south or north pole of a permanent magnet (e.g. SmCO<sub>5</sub> (Vacuumschmelze VX145) with the dimensions 8 mm x 5 mm x 3 mm) which should cover both Hall probes.

The maximum air gap depends on:

- the magnetic field strength (magnet used; pre-induction) and
- the toothed wheel that is used (dimensions, material, etc.; resulting differential field).

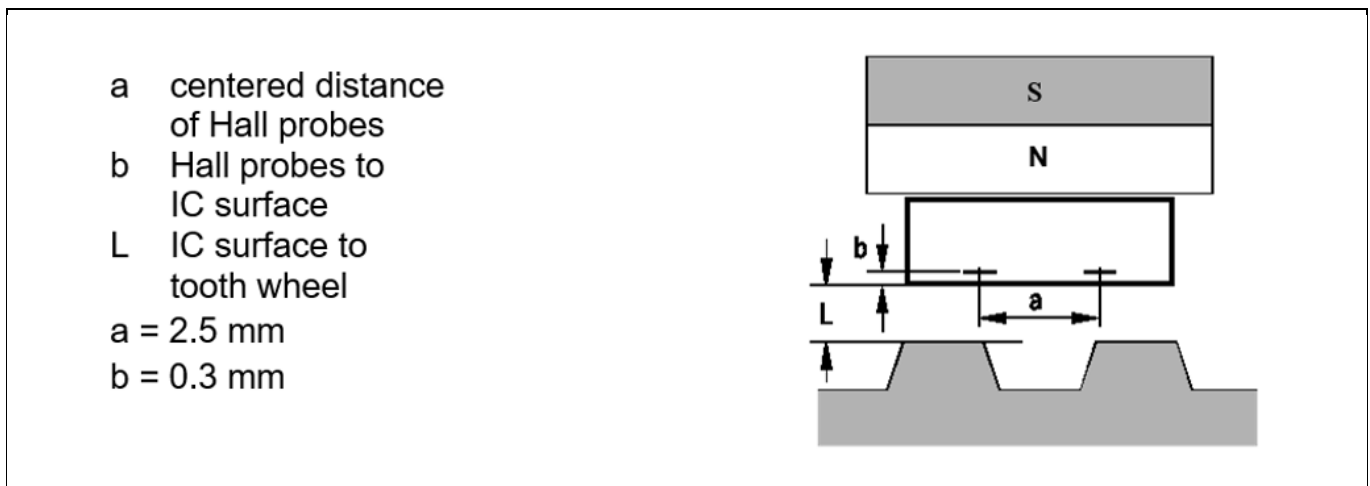

Figure 6 Sensor spacing

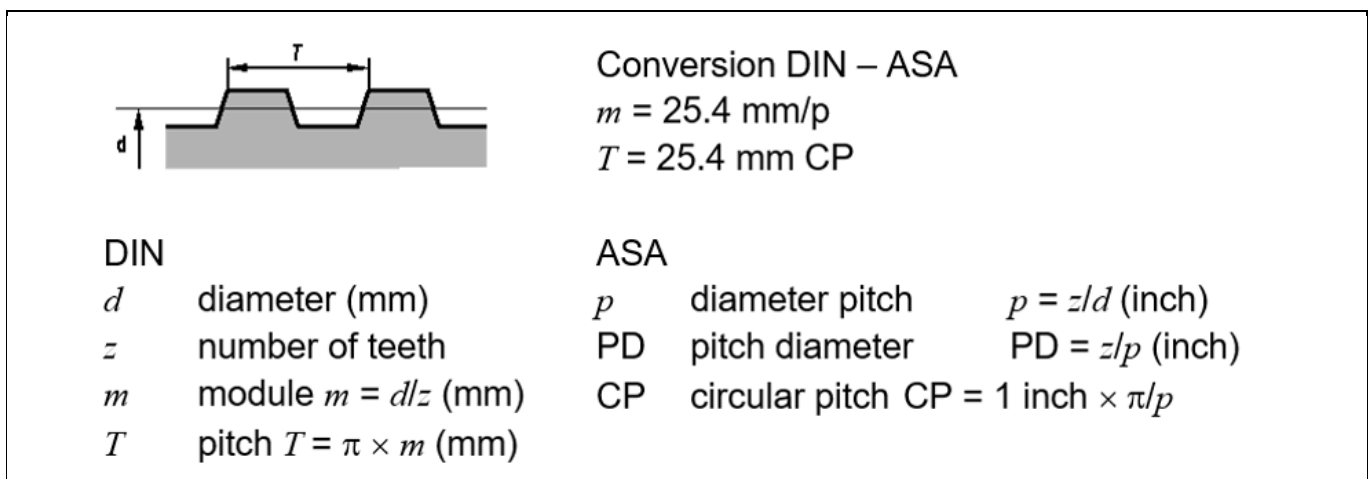

Figure 7 Toothed wheel dimensions

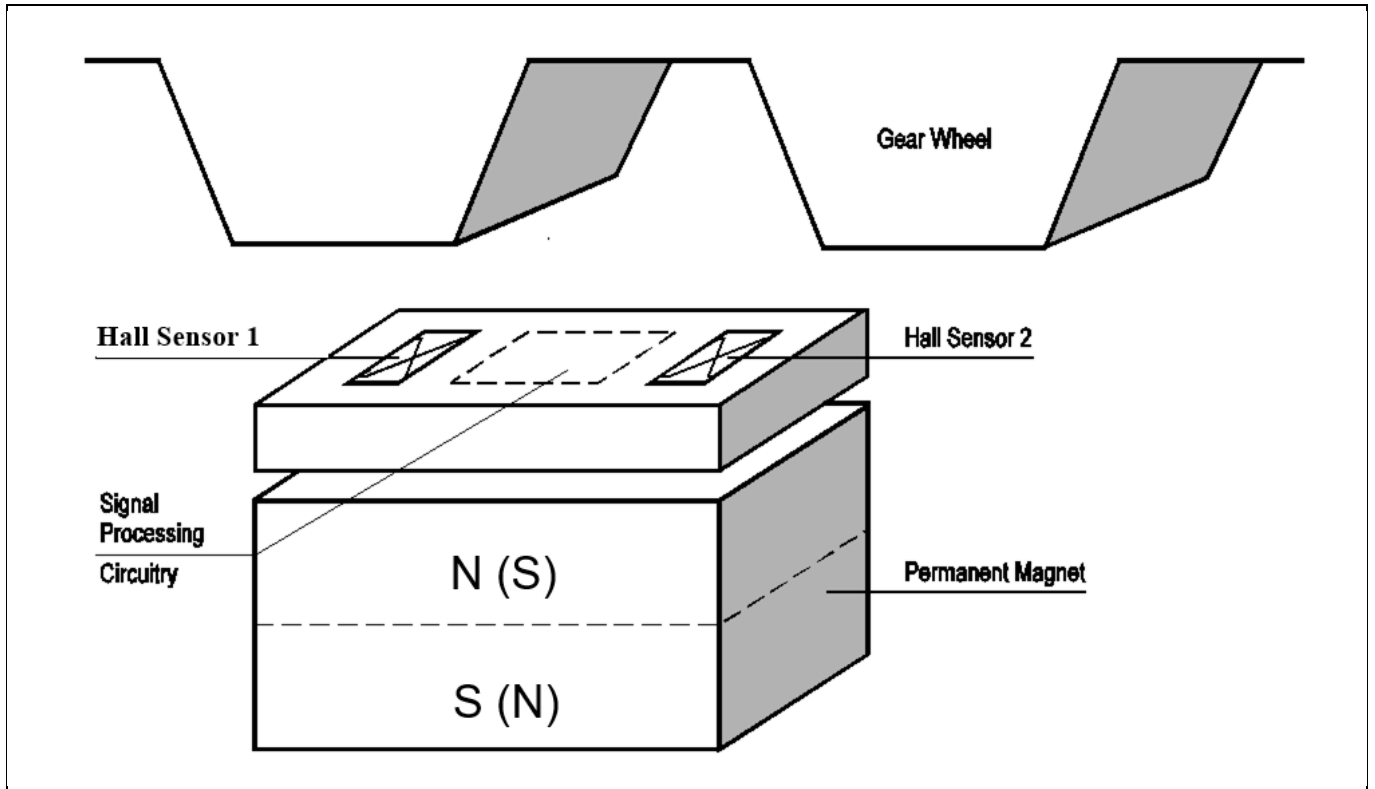

Figure 8 TLE4927C, with ferromagnetic toothed wheel

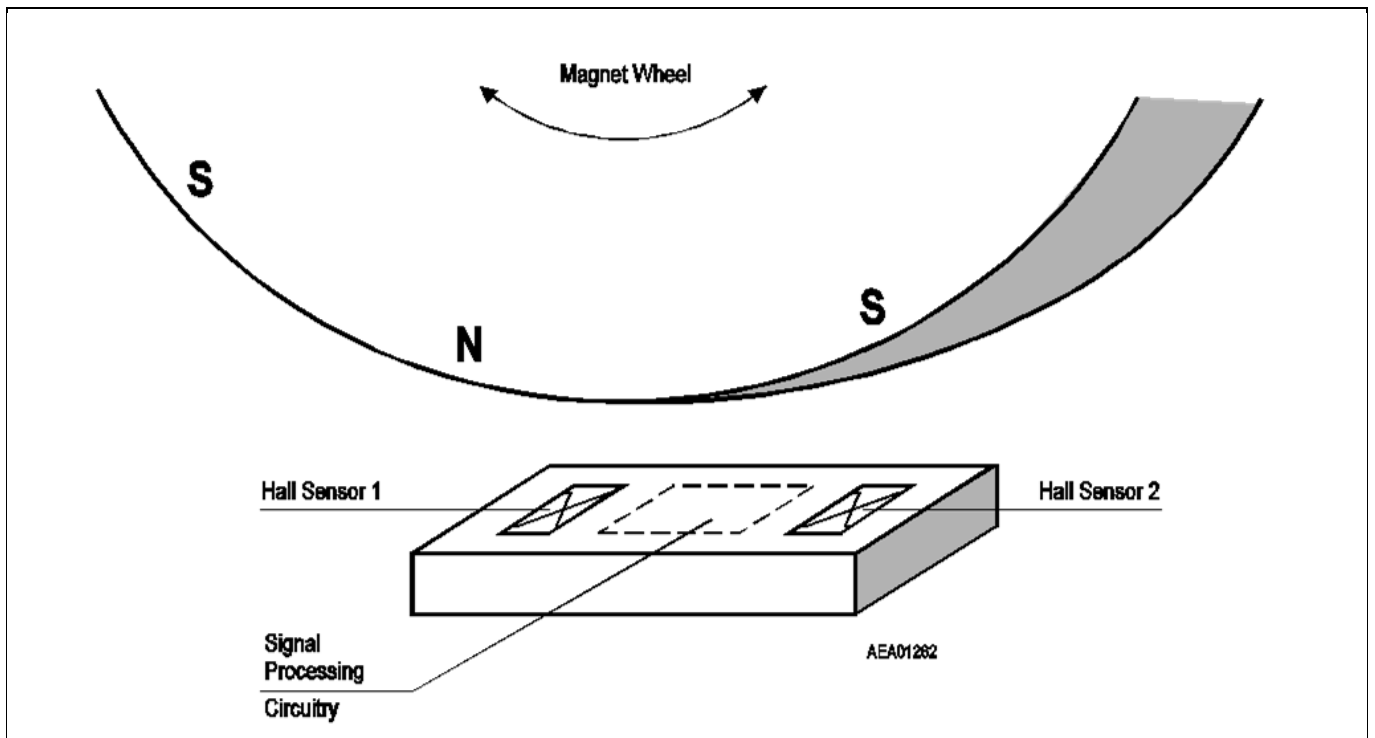

Figure 9 TLE4927C, with magnet wheel

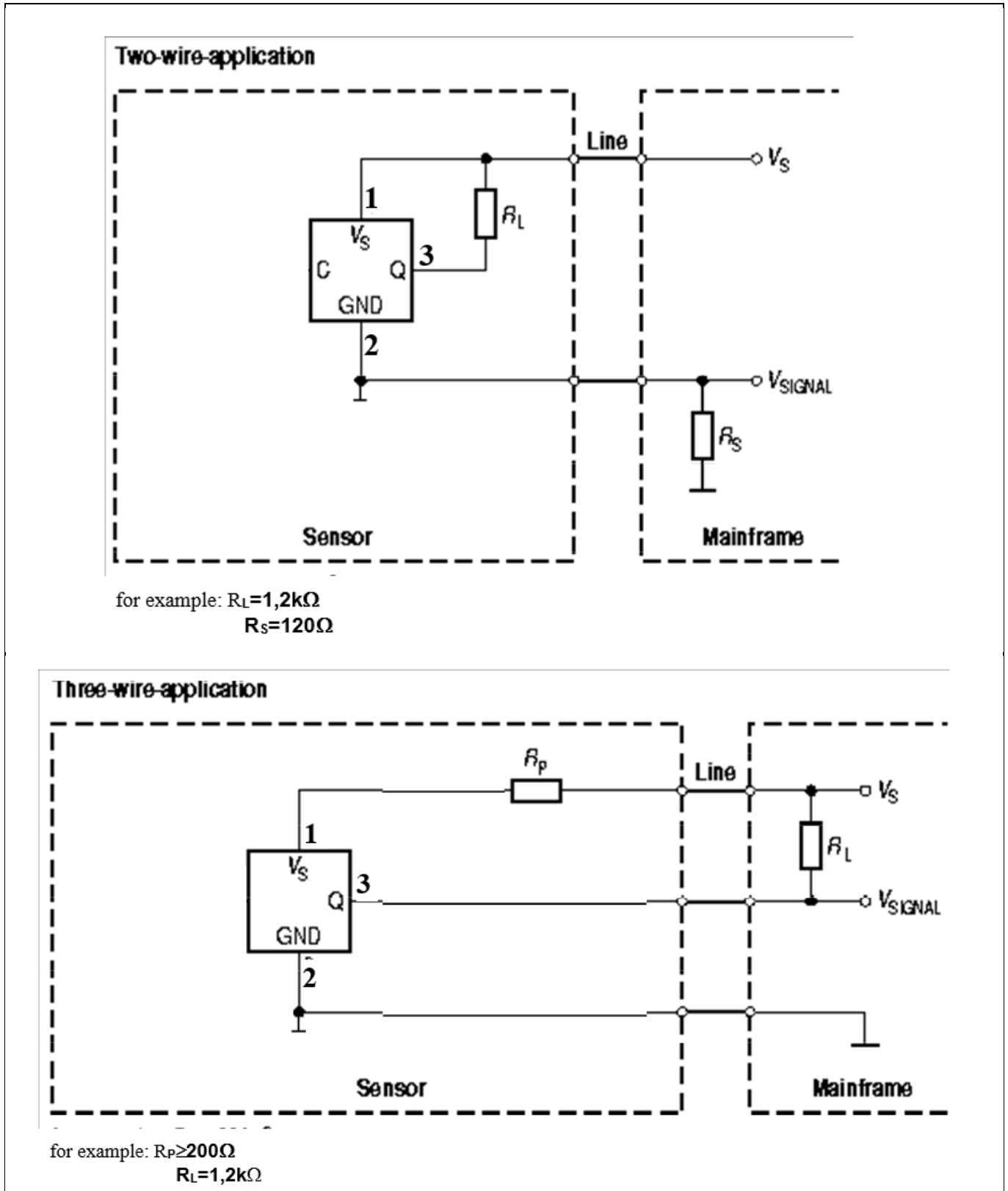

Figure 10 Application circuits TLE4927C (capacitors included in package)

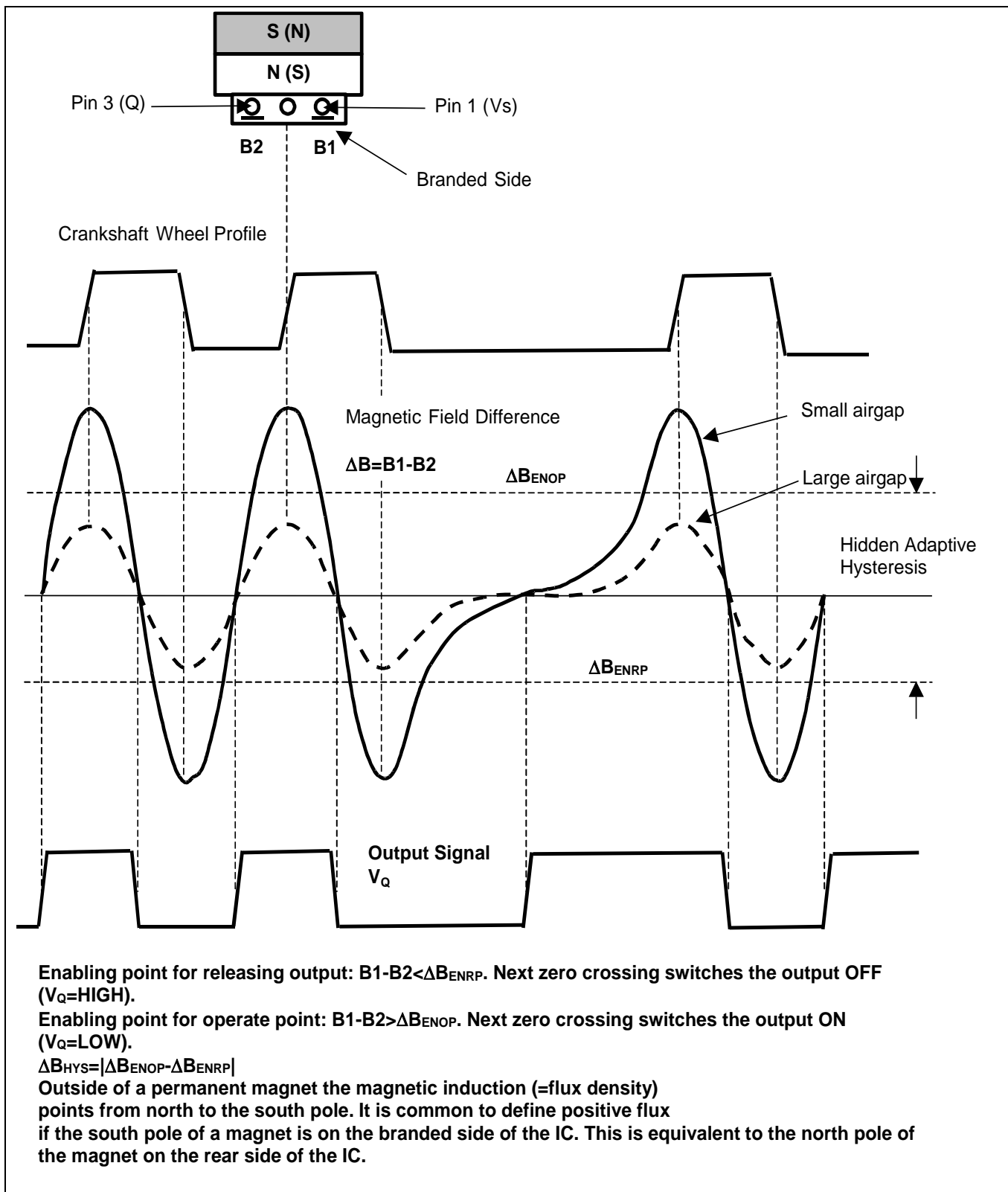

Figure 11 System operation with hidden hysteresis



## 4 Electro Magnetic Compatibility

Note: Values depend on  $R_{Series}$ !

Ref. ISO 7637-2, 2<sup>nd</sup> edition 06/2004, test circuit of Figure 12, conducted on supply line.  $\Delta B_{pp} = 10\text{mT}$  (ideal sinusoidal signal),  $V_S = 13.5\text{V} \pm 0.5\text{V}$ ,  $f_B = 1000\text{Hz}$ ,  $T = 25^\circ\text{C}$ ,  $R_{Series} \geq 200\Omega$

### ISO 7637-2

Parameter	Symbol	Level/Type	Status
Test pulse 1	$V_{EMC}$	IV / -100V	C
Test pulse 2a		IV / 50V	C
Test pulse 2b		IV / 10V	C
Test pulse 3a		IV / -150V	A <sup>16</sup>
Test pulse 3b		IV / 100V	A <sup>16</sup>
Test pulse 5a		IV / 86.5V	C
Test pulse 5b		IV / 86.5V	A <sup>17</sup>

Note: Test criteria for status A: No missing pulse no additional pulse on the IC output signal plus duty cycle and jitter are in the specification limits

Test criteria for status B: No missing pulse no additional pulse on the IC output signal. (Output signal "OFF" means switching to the voltage of the pull-up resistor).

Test criteria for status C: One or more parameter can be out of specification during the exposure but returns automatically to normal operation after exposure is removed.

Test criteria for status E: IC destroyed

Ref. ISO 7637-3, 1<sup>st</sup> edition 11/1995, test circuit of Figure 12, coupling clamp.

$\Delta B_{pp} = 10\text{mT}$  (ideal sinusoidal signal),  $V_S = 13.5\text{V} \pm 0.5\text{V}$ ,  $f_B = 1000\text{Hz}$ ,  $T = 25^\circ\text{C}$ ,  $R_{Series} \geq 200\Omega$ .

### ISO 7637-3

Parameter	Symbol	Level/Type	Status
Test pulse 3a	$V_{EMC}$	IV / -60V	A <sup>16</sup>
Test pulse 3b		IV / 40V	A <sup>16</sup>

Ref. ISO 11452-3, test circuit of Figure 12, measured in TEM-cell.

$\Delta B_{pp} = 4\text{mT}$  (ideal sinusoidal signal),  $V_S = 13.5\text{V} \pm 0.5\text{V}$ ,  $f_B = 200\text{Hz}$ ,  $T = 25^\circ\text{C}$ ,  $R_{Series} \geq 200\Omega$ .

### ISO 11452-3

Parameter	Symbol	Level/Type	Status
EMC field strength	$E_{TEM-Cell}$	IV / 200V/m	AM=80%, f=1kHz

Note: Stresses above those listed here may cause permanent damage to the device. Exposure to absolute maximum rating conditions for extended periods may affect device reliability. Test condition for the trigger window:  $f_{B-field} = 200\text{Hz}$ ,  $B_{pp} = 4\text{mT}$ , vertical limits are  $\pm 10\%$  of  $V_Q$  and horizontal limits are  $\pm 200\mu\text{s}$

<sup>16</sup> Output signal overlaid by burst pulse

<sup>17</sup> Suppressed  $U_S^* = 35\text{V}$

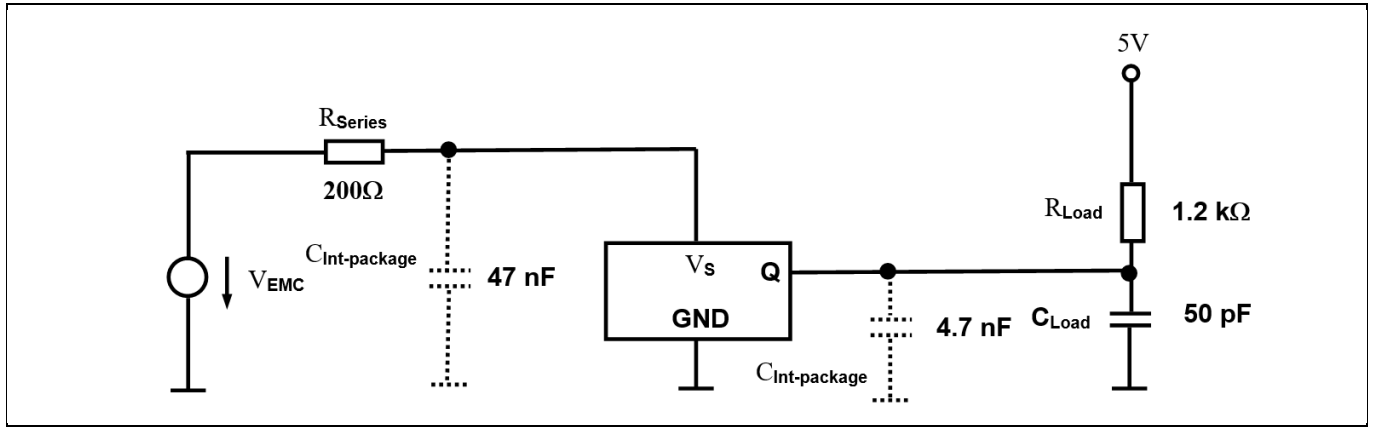

Figure 12 Test Circuit of EMC Tests

## 5 Package Information

Pure tin covering (green lead plating) is used. Product is RoHS (Restriction of Hazardous Substances) compliant and marked with letter G in front of the data code marking and may contain a data matrix code on the rear side of the package. Please refer to your key account team or regional sales if your need further information

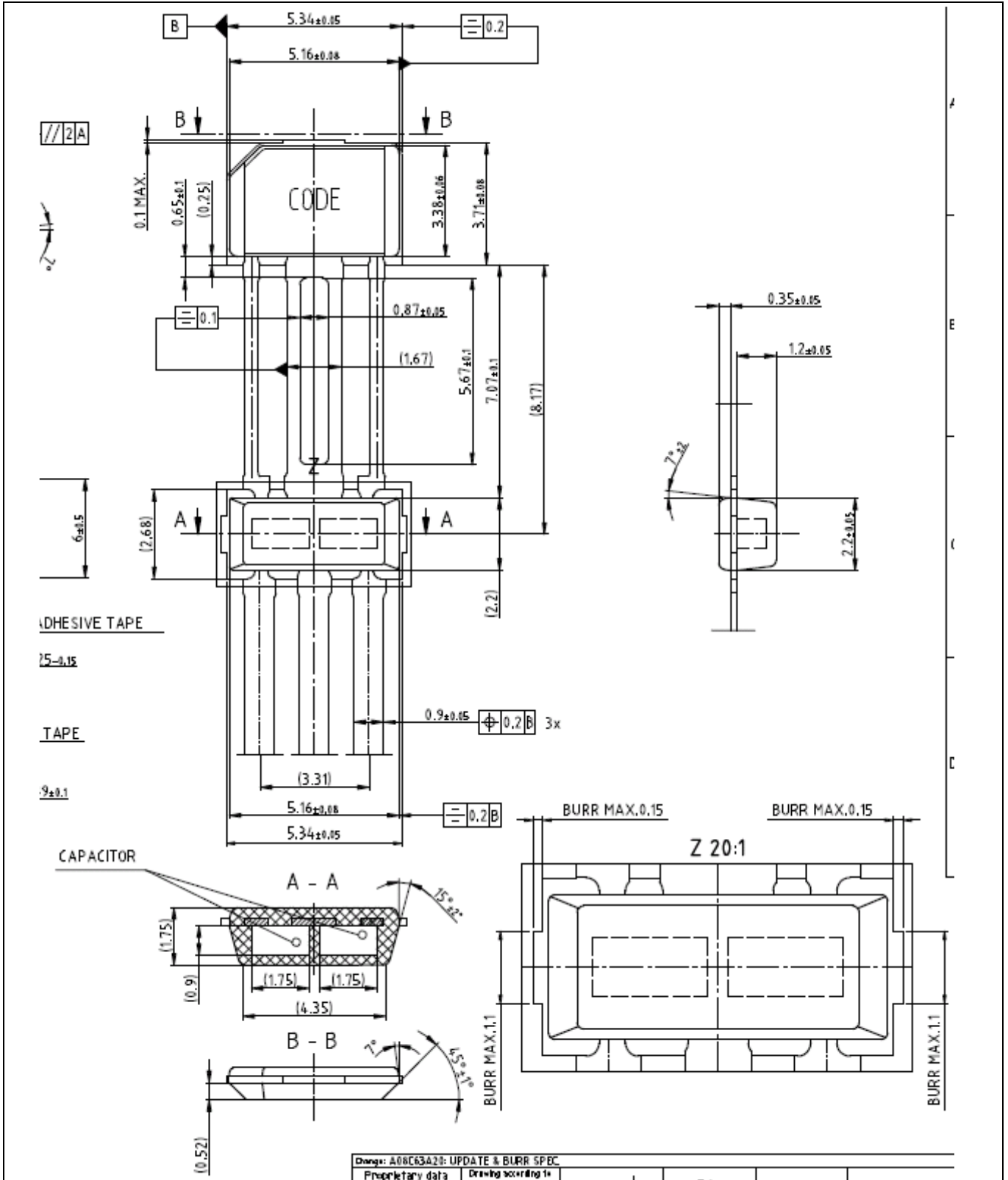
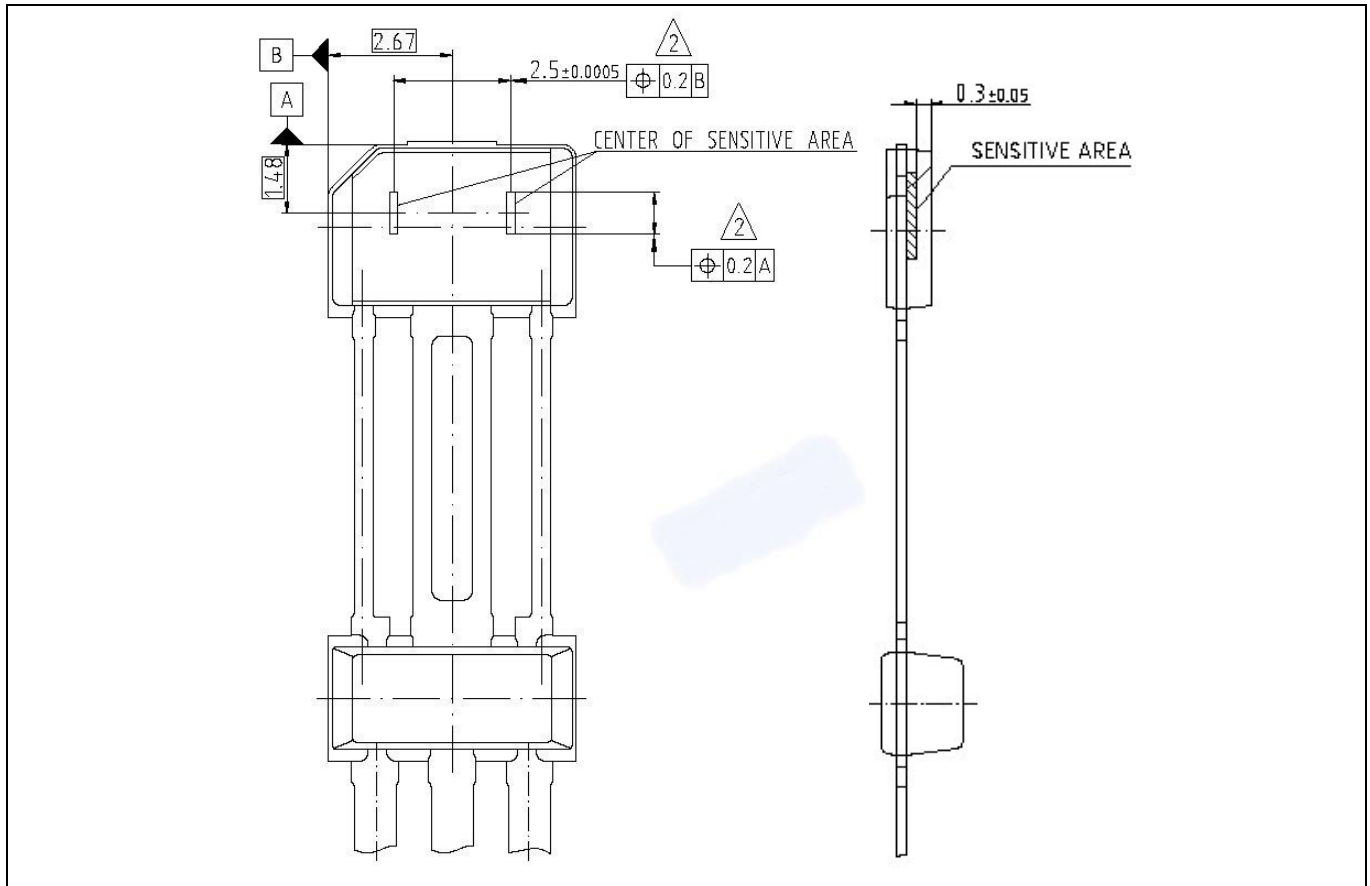
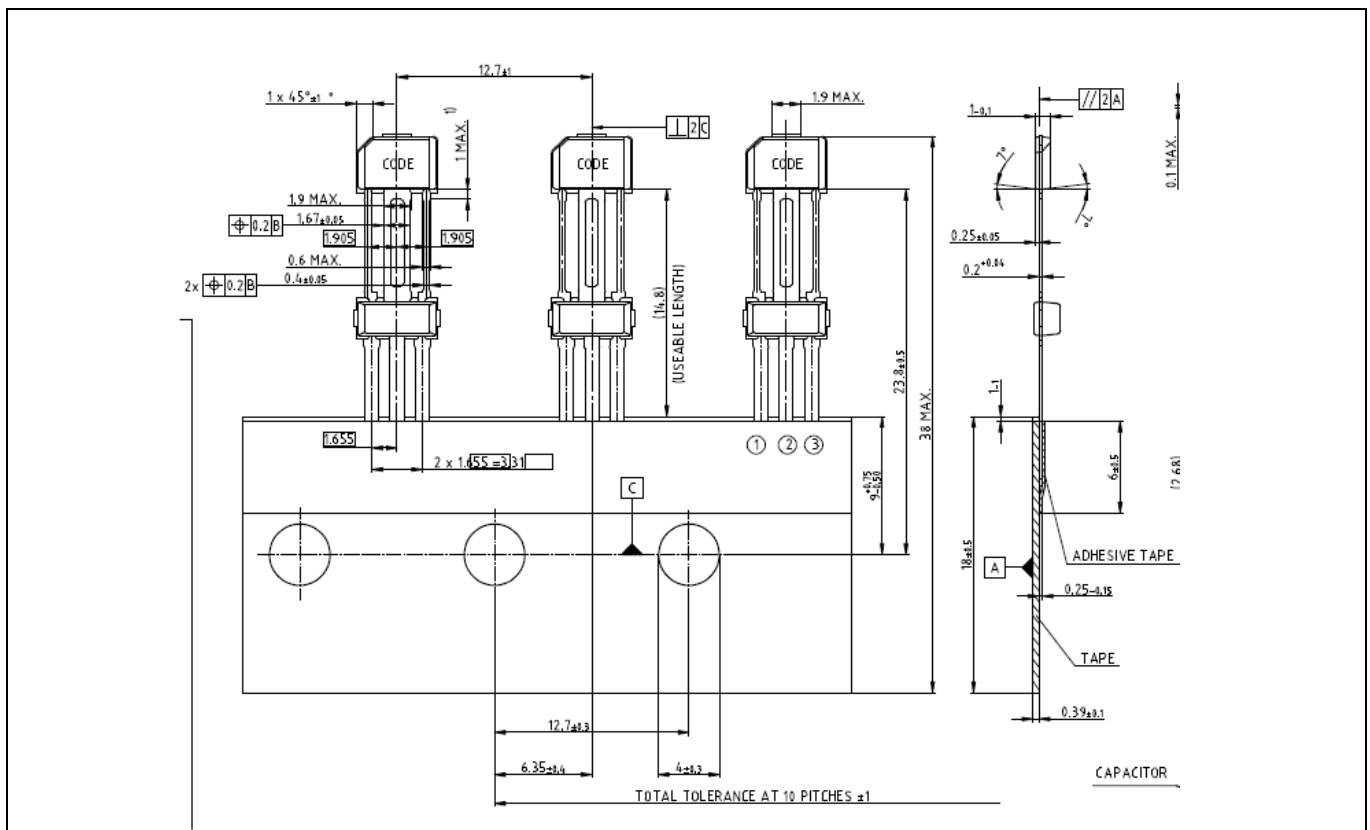

Figure 13 PG-SSO-3-92 (Plastic Green Single Small Outline)



**Figure 14** Hall probe spacing in the PG-SSO-3-92 package



**Figure 15** Tape Loading Orientation in the PG-SSO-3-92 package

**Appendix:**

**Calculation of mechanical errors**

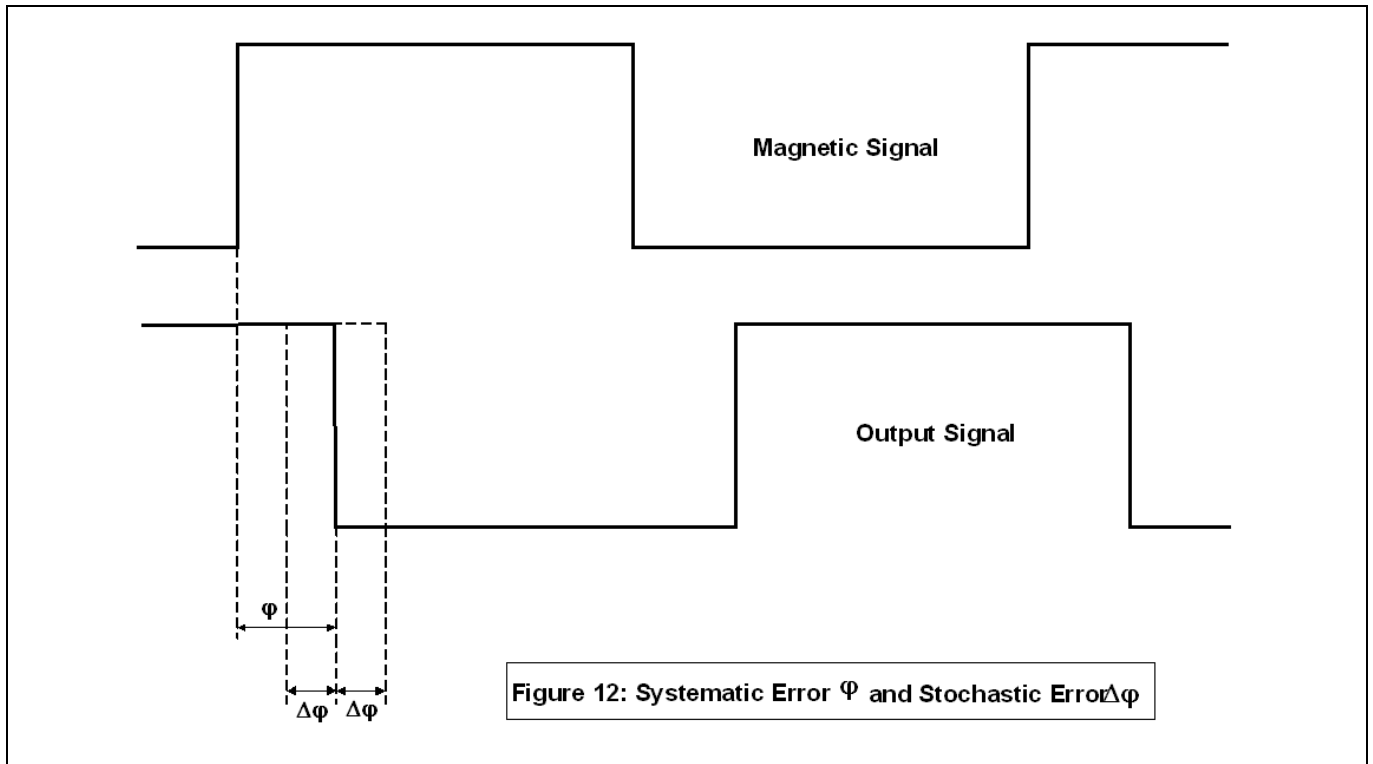

**Figure 16 Systematic Phase Error  $\varphi$**

The systematic error comes in because of the delay-time between the threshold point and the time when the output is switching. It can be calculated as follows:

$$\varphi = \frac{360^\circ \cdot n}{60} \cdot t_d$$

$\varphi$  ... systematic phase error in  $^\circ$   
 $n$  ... speed of the camshaft-wheel in  $\text{min}^{-1}$   
 $t_d$  ... delay time (see specification) in sec

**Figure 17 Systematic Phase Error  $\varphi$**

The stochastic phase error includes the error due to the variation of the delay time with temperature and the error caused by the resolution of the threshold. It can be calculated in the following way:

$$\Delta\varphi_d = \frac{360^\circ \cdot n}{60} \cdot \Delta t_d$$

$\Delta\varphi_d$  ... stochastic phase error due to the variation of the delay time over temperature in  $^\circ$   
 $n$  ... speed of the camshaft wheel in  $\text{min}^{-1}$   
 $\Delta t_d$  ... variation of delay time over temperature in sec

**Figure 18 Stochastic Phase Error  $\Delta\varphi$**

Jitter (Repeatability)

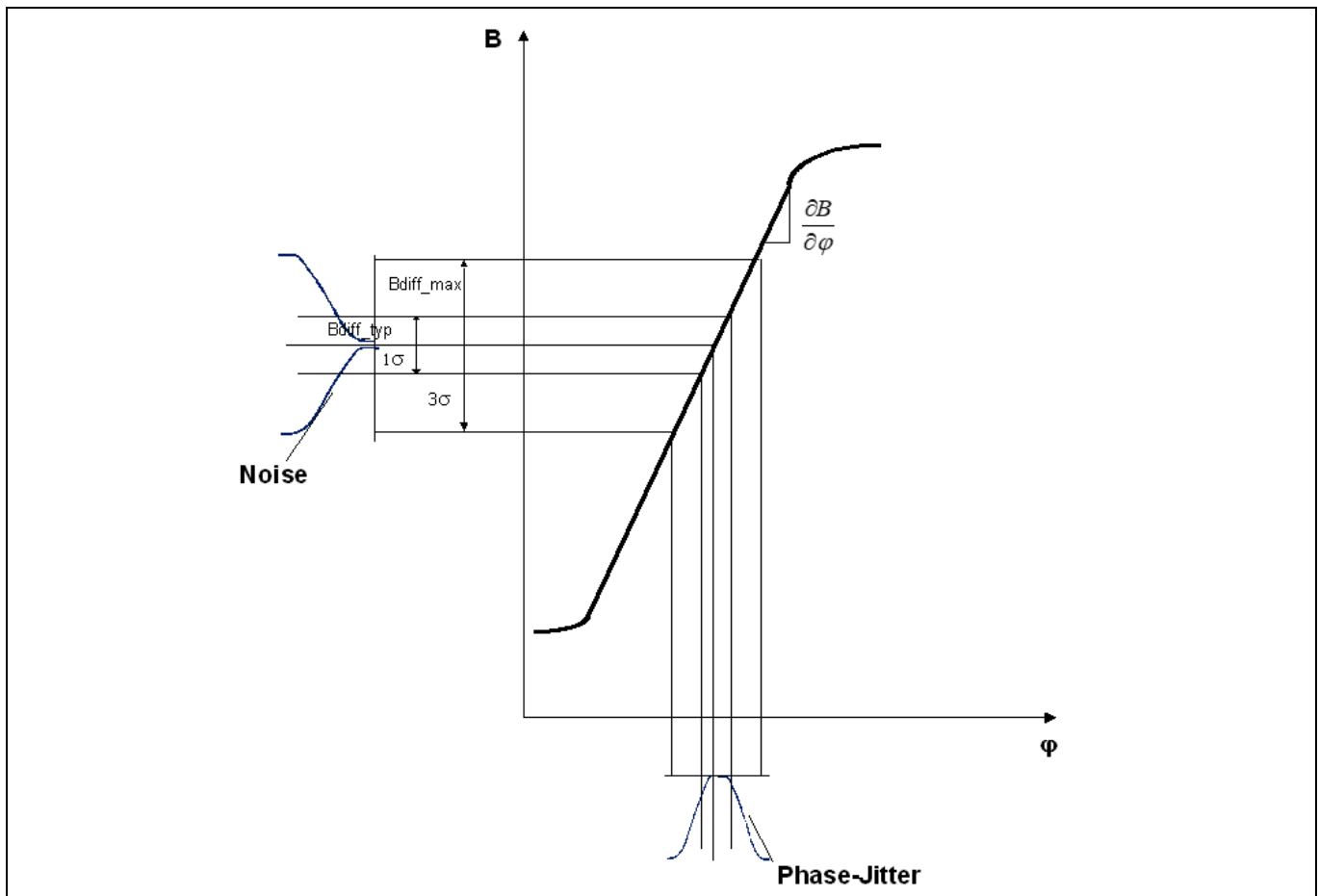

Figure 19 Phase Jitter

The phase jitter is normally caused by the analogue system noise. If there is an update of the offset-DAC due to the algorithm, what could happen after each tooth, then an additional step in the phase occurs (see description of the algorithm). This is not included in the following calculations. The noise is transformed through the slope of the magnetic edge into a phase error. The phase jitter is determined by the two formulas:

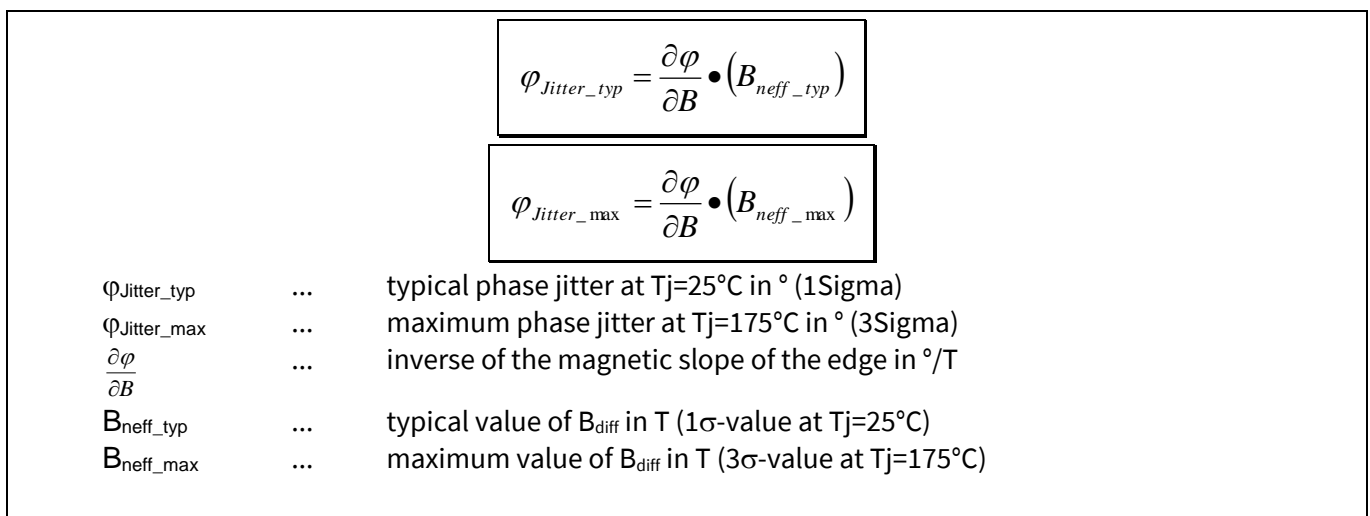

Figure 20 Phase Jitter Calculation

---

**Package Information**
**Example**Assumption:  $n = 4500 \text{ min}^{-1}$ 

$$t_d = 14 \mu\text{s}$$

$$\Delta t_d = \pm 3 \mu\text{s}$$

$$\frac{\partial B}{\partial \varphi} = 3 \text{ mT/}^\circ$$

$$B_{\text{neff\_typ}} = \pm 40 \mu\text{T} \text{ (1}\sigma\text{-value at } T_j=25^\circ\text{C)}$$

$$B_{\text{neff\_max}} = \pm 210 \mu\text{T} \text{ (3}\sigma\text{-value at } T_j=175^\circ\text{C)}$$

Calculation:

$\varphi = 0.378^\circ$	...	systematic phase error
$\Delta\varphi_d = \pm 0.081^\circ$	...	stochastic phase error due to delay time variation
$\varphi_{\text{Jitter\_typ}} = \pm 0.013^\circ$	...	typical phase jitter (1 $\sigma$ -value at $T_j=25^\circ\text{C}$ )
$\varphi_{\text{Jitter\_max}} = \pm 0.07^\circ$	...	maximum phase jitter (3 $\sigma$ -value at $T_j=175^\circ\text{C}$ )

**Revision history****Revision history**

<b>Document version</b>	<b>Date of release</b>	<b>Description of changes</b>
1.0	2022-05-10	Initial release. Document integration of “Data sheet TLE4926C-HT E6547 version 1.1” (Sensor reference type) and “Data sheet supplement TLE4927C E6547 version 1.0”. Editorial changes.



## Trademarks

All referenced product or service names and trademarks are the property of their respective owners.

**Edition 2022-05-10**

**Published by**

**Infineon Technologies AG**

**81726 München, Germany**

**© 2022 Infineon Technologies AG.**

**All Rights Reserved.**

**Do you have a question about this document?**

**Email: [erratum@infineon.com](mailto:erratum@infineon.com)**

**Document reference**

## IMPORTANT NOTICE

The information given in this document shall in no event be regarded as a guarantee of conditions or characteristics ("Beschaffheitsgarantie").

With respect to any examples, hints or any typical values stated herein and/or any information regarding the application of the product, Infineon Technologies hereby disclaims any and all warranties and liabilities of any kind, including without limitation warranties of non-infringement of intellectual property rights of any third party.

In addition, any information given in this document is subject to customer's compliance with its obligations stated in this document and any applicable legal requirements, norms and standards concerning customer's products and any use of the product of Infineon Technologies in customer's applications.

The data contained in this document is exclusively intended for technically trained staff. It is the responsibility of customer's technical departments to evaluate the suitability of the product for the intended application and the completeness of the product information given in this document with respect to such application.

For further information on the product, technology, delivery terms and conditions and prices please contact your nearest Infineon Technologies office ([www.infineon.com](http://www.infineon.com)).

## WARNINGS

Due to technical requirements products may contain dangerous substances. For information on the types in question please contact your nearest Infineon Technologies office.

Except as otherwise explicitly approved by Infineon Technologies in a written document signed by authorized representatives of Infineon Technologies, Infineon Technologies' products may not be used in any applications where a failure of the product or any consequences of the use thereof can reasonably be expected to result in personal injury.