

Important notice

“Evaluation Boards and Reference Boards” shall mean products embedded on a printed circuit board (PCB) for demonstration and/or evaluation purposes, which include, without limitation, demonstration, reference and evaluation boards, kits and design (collectively referred to as “Reference Board”).

Environmental conditions have been considered in the design of the Evaluation Boards and Reference Boards provided by Infineon Technologies. The design of the Evaluation Boards and Reference Boards has been tested by Infineon Technologies only as described in this document. The design is not qualified in terms of safety requirements, manufacturing and operation over the entire operating temperature range or lifetime.

The Evaluation Boards and Reference Boards provided by Infineon Technologies are subject to functional testing only under typical load conditions. Evaluation Boards and Reference Boards are not subject to the same procedures as regular products regarding returned material analysis (RMA), process change notification (PCN) and product discontinuation (PD).

Evaluation Boards and Reference Boards are not commercialized products, and are solely intended for evaluation and testing purposes. In particular, they shall not be used for reliability testing or production. The Evaluation Boards and Reference Boards may therefore not comply with CE or similar standards (including but not limited to the EMC Directive 2004/EC/108 and the EMC Act) and may not fulfill other requirements of the country in which they are operated by the customer. The customer shall ensure that all Evaluation Boards and Reference Boards will be handled in a way which is compliant with the relevant requirements and standards of the country in which they are operated.

The Evaluation Boards and Reference Boards as well as the information provided in this document are addressed only to qualified and skilled technical staff, for laboratory usage, and shall be used and managed according to the terms and conditions set forth in this document and in other related documentation supplied with the respective Evaluation Board or Reference Board.

It is the responsibility of the customer’s technical departments to evaluate the suitability of the Evaluation Boards and Reference Boards for the intended application, and to evaluate the completeness and correctness of the information provided in this document with respect to such application.

The customer is obliged to ensure that the use of the Evaluation Boards and Reference Boards does not cause any harm to persons or third party property. The Evaluation Boards and Reference Boards and any information in this document is provided "as is" and Infineon Technologies disclaims any warranties, express or implied, including but not limited to warranties of non-infringement of third party rights and implied warranties of fitness for any purpose, or for merchantability.

Infineon Technologies shall not be responsible for any damages resulting from the use of the Evaluation Boards and Reference Boards and/or from any information provided in this document. The customer is obliged to defend, indemnify and hold Infineon Technologies harmless from and against any claims or damages arising out of or resulting from any use thereof.

Infineon Technologies reserves the right to modify this document and/or any information provided herein at any time without further notice.

		Infineon Technologies AG	
		81726 München Germany	
Title	EVAL-XMC4800PSOC6M5		
Variant	Default_Assembly		
Size:	Document Name	Rev.	
A3	00_Disclaimer.SchDoc	V 1.0	
Date: 2023/9/13		Time: 18:49:49	
© 1999 - 2023 Infineon Technologies AG		Sheet 1 of 13	

Index

01_Revision_History.SchDoc

Revision History

Page	Schematics Page Name
00	00_Disclaimer
01	01_Revision_History
02	02_BlockDiagram-total
03	03_BlockDiagram-Powersupply
04	04_Top level diagram
05	05_Connectvity with PSoC62+43012
06	06_Motor control section
07	07_M5 interface and functional blocks
08	08_Add-on connectors
09	09_On board debugger(OBD)
10	10_OBD-PSOC
11	11_OBD-XMC
12	12_Power supply

Rev.	Rel.	Date	Author	Description	Page(s)
1.0		2023-09-04		- Initial design	

EVAL-XMC4800PSOC6M5

Default_Assembly

V 1.0



Infineon Technologies AG
81726 München
Germany

2023

Link to Top Level Document

02_BlockDiagram-total

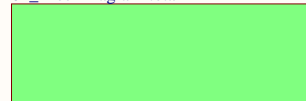

03_BlockDiagram-Powersupply



04_Top level diagram



LEGAL DISCLAIMER

THE INFORMATION GIVEN IN THIS DOCUMENT IS GIVEN FOR ILLUSTRATING PURPOSES ONLY. THE RECIPIENT OF THIS DOCUMENT MUST VERIFY ANY FUNCTION DESCRIBED HEREIN IN THE REAL APPLICATION. INFINEON TECHNOLOGIES HEREBY DISCLAIMS ANY AND ALL WARRANTIES AND LIABILITIES OF ANY KIND (INCLUDING WITHOUT LIMITATION WARRANTIES OF NON-INFRINGEMENT OF INTELLECTUAL PROPERTY RIGHTS OF ANY THIRD PARTY) WITH RESPECT TO ANY AND ALL INFORMATION GIVEN IN THIS DOCUMENT.



Infineon Technologies AG

81726 München
Germany

Title	EVAL-XMC4800PSOC6M5	
Variant	Default_Assembly	
Size:	Document Name	Rev.
A3	01_Revision_History.SchDoc	V 1.0
Date: 2023/9/13 Time: 18:49:49		
© 1999 - 2023 Infineon Technologies AG		
Sheet 2		of 13

02_BlockDiagram-total.SchDoc

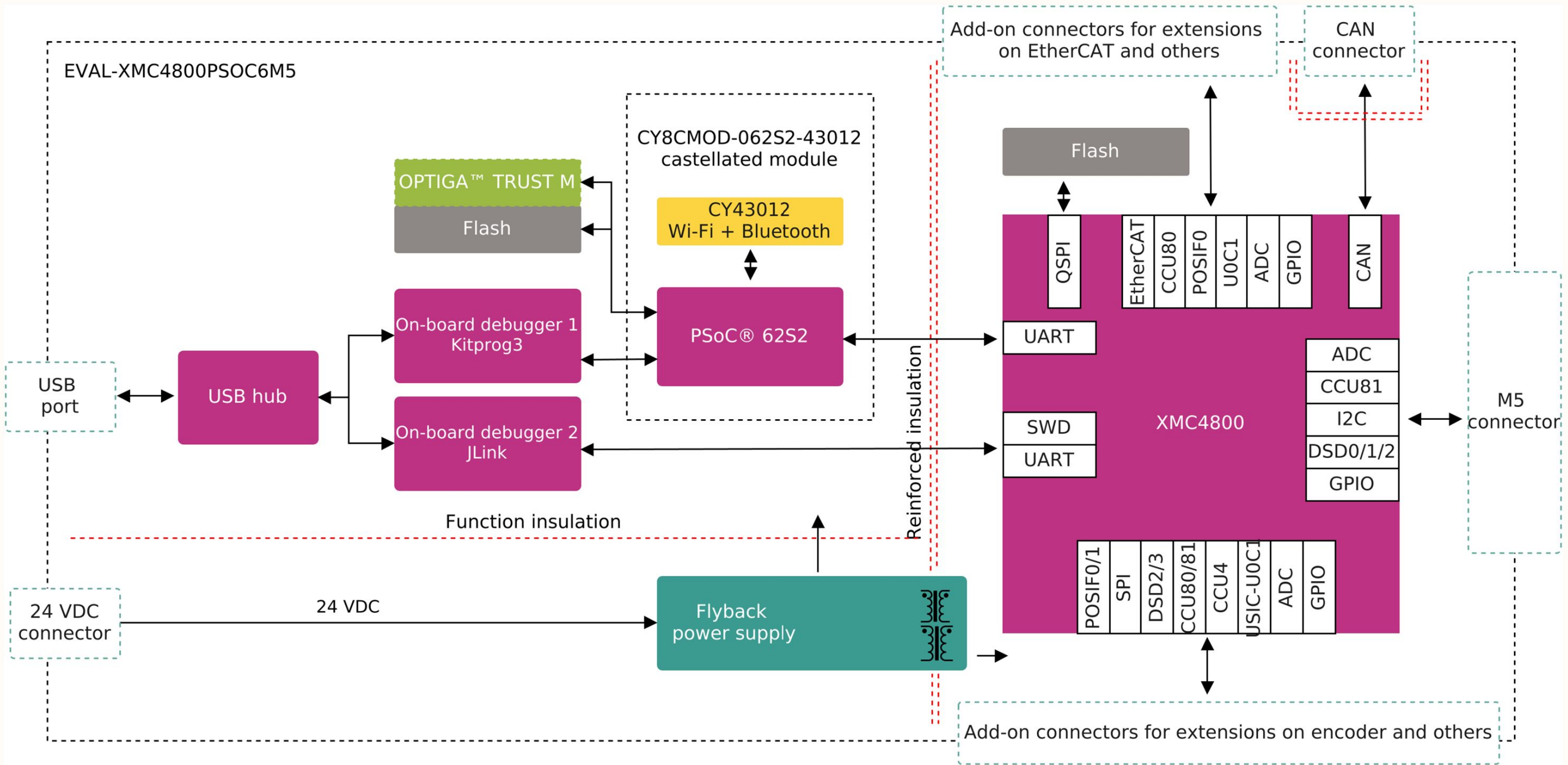

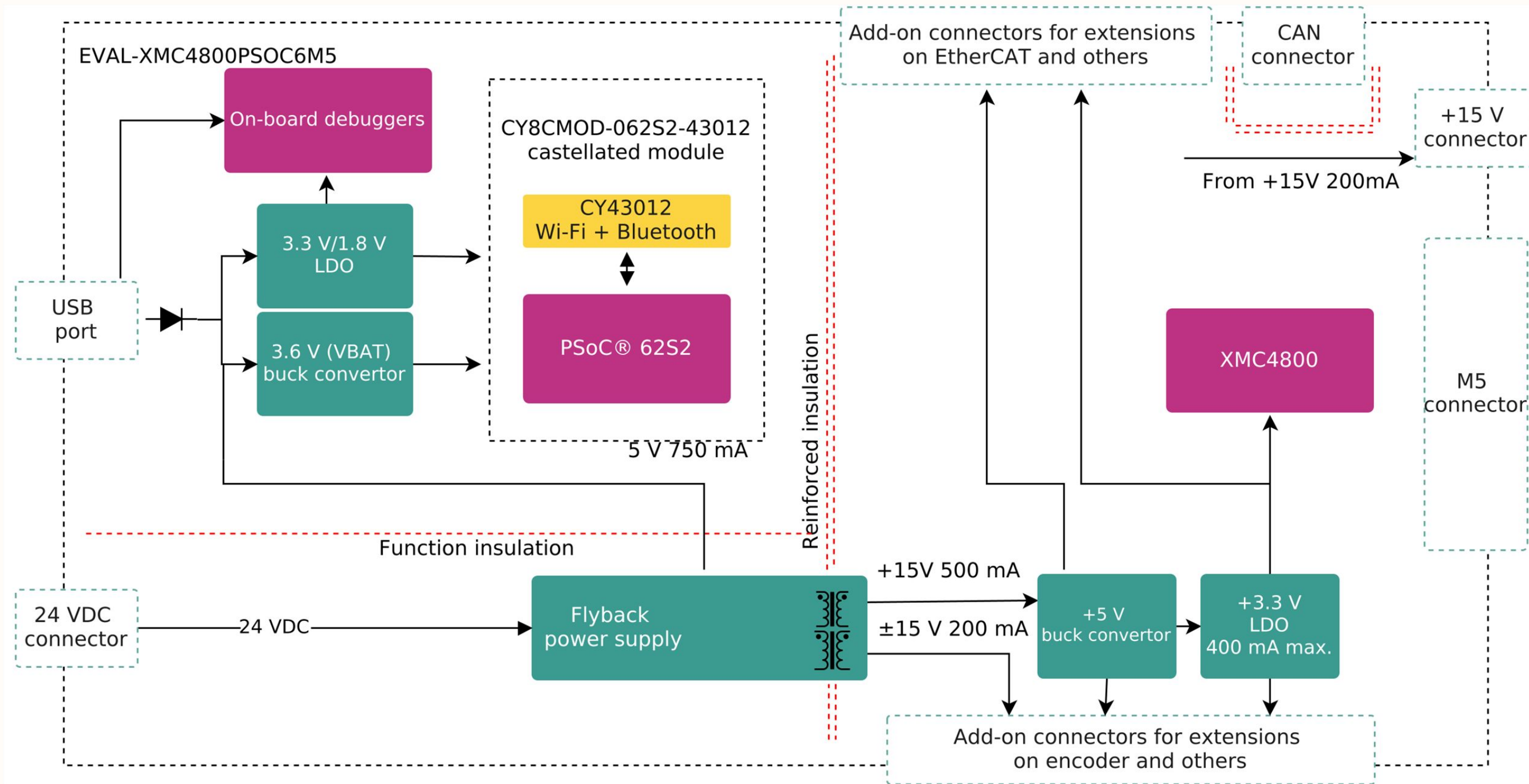

03_BlockDiagram-Powersupply.SchDoc

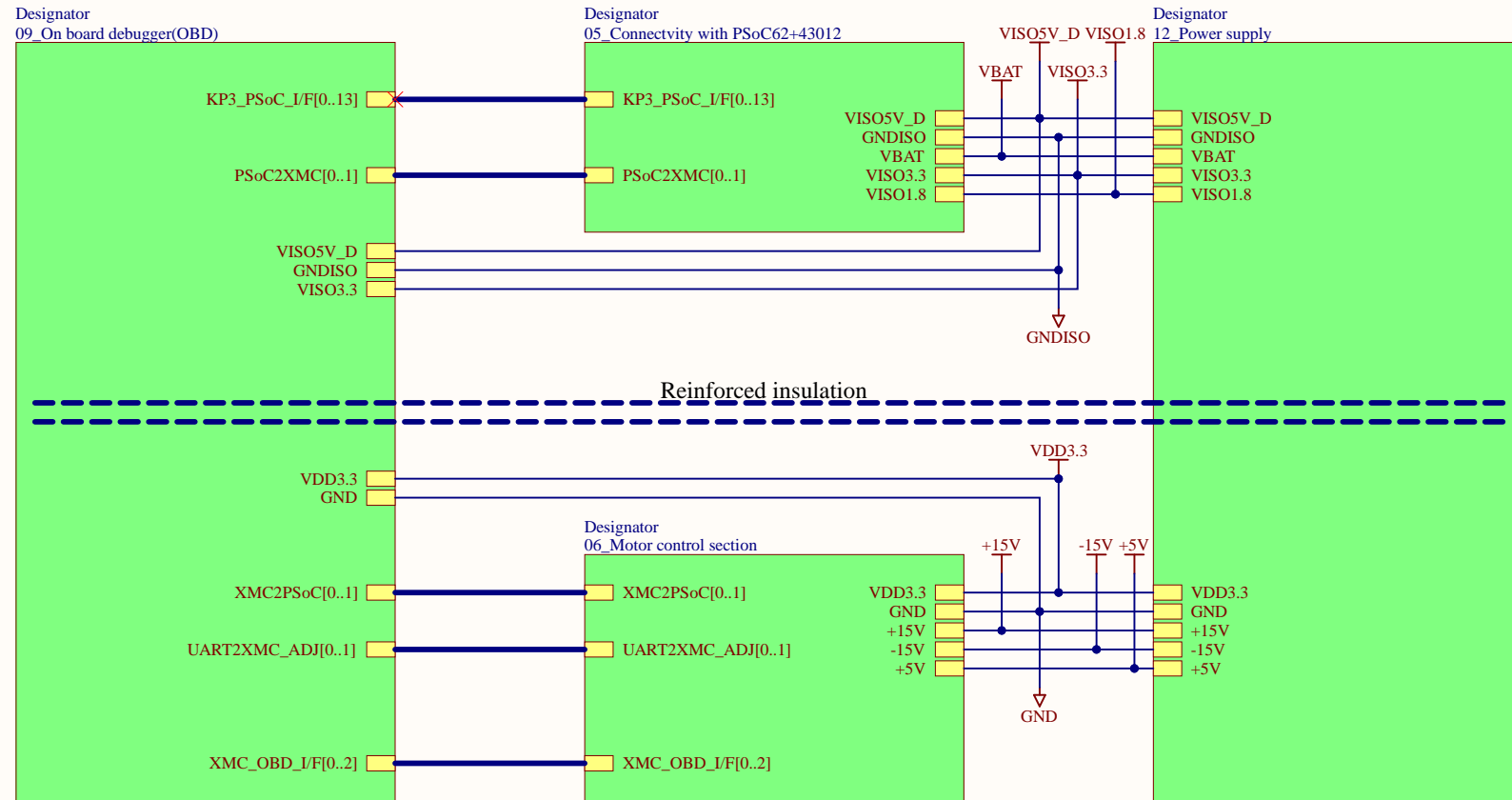

 Infineon Technologies AG 81726 München Germany		
		Title: EVAL-XMC4800PSOC6M5
Variant: Default_Assembly		
Size: A3	Document Name: 03_BlockDiagram-Powersupply.SchDoc	Rev.: V 1.0
Date: 2023/9/13 Time: 18:49:49		© 1999 - 2023 Infineon Technologies AG
Sheet 4 of 13		

04_Top level diagram.SchDoc



 Infineon Technologies AG 81726 München Germany		
		Title EVAL-XMC4800PSOC6M5
Variant Default_Assembly		
Size: A3	Document Name: 04_Top level diagram.SchDoc	Rev. V 1.0
Date: 2023/9/13 Time: 18:49:50		© 1999 - 2023 Infineon Technologies AG
Sheet 5 of 13		

05_Connectivity with PSoC62+43012.SchDoc

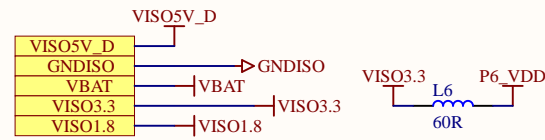

1.8V load switch

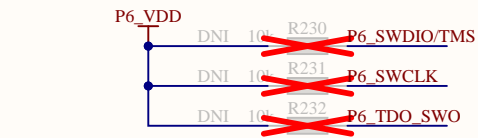
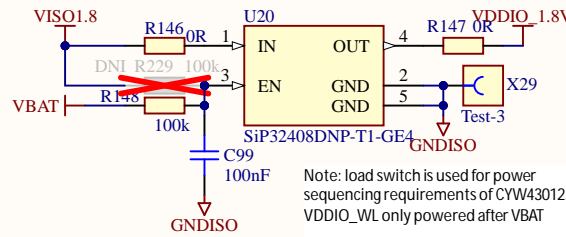

ETM connector for PSoC62

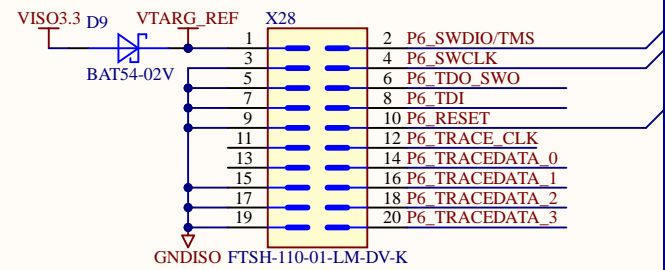

PSoC62 10pin SWD/JTAG header

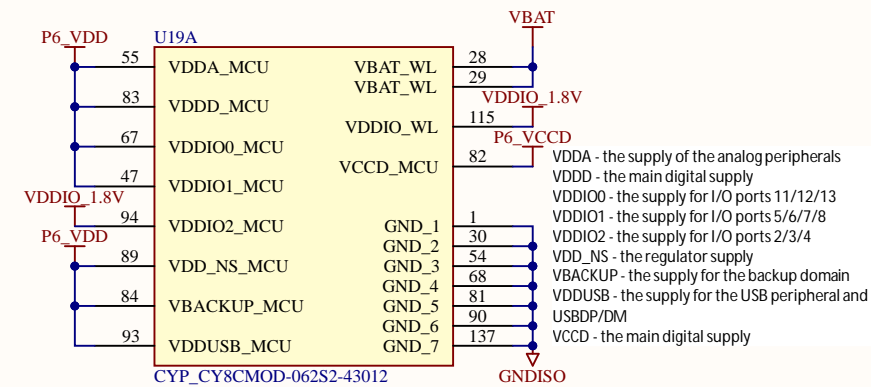
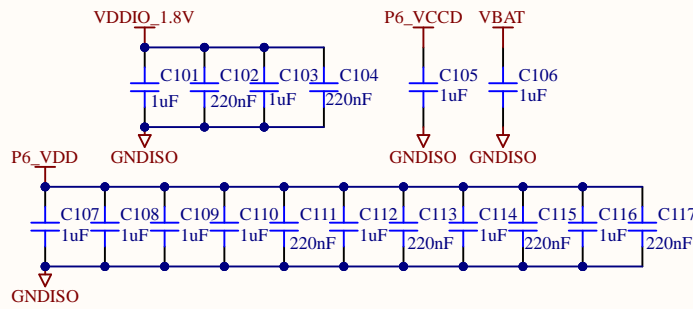
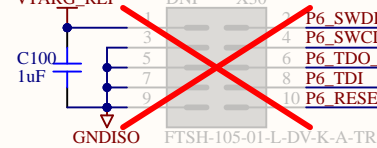

Debug connector for WL

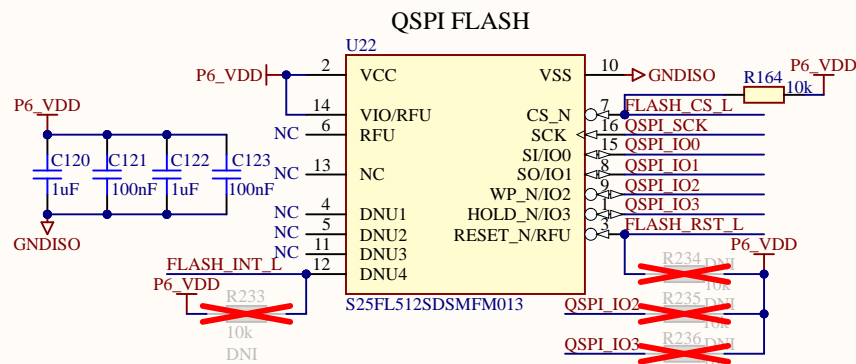
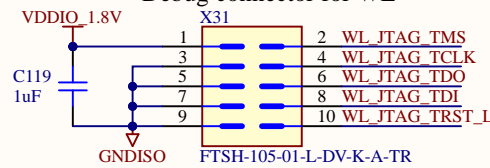

QSPI FLASH

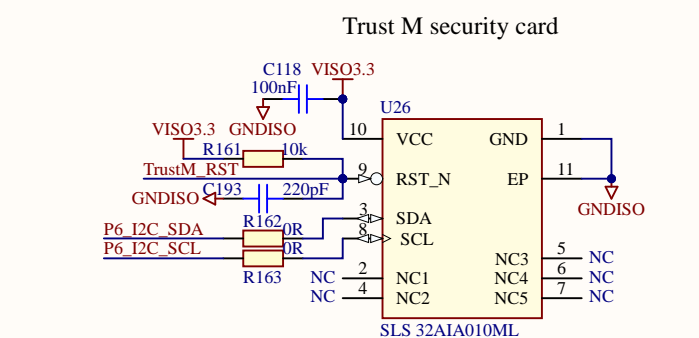
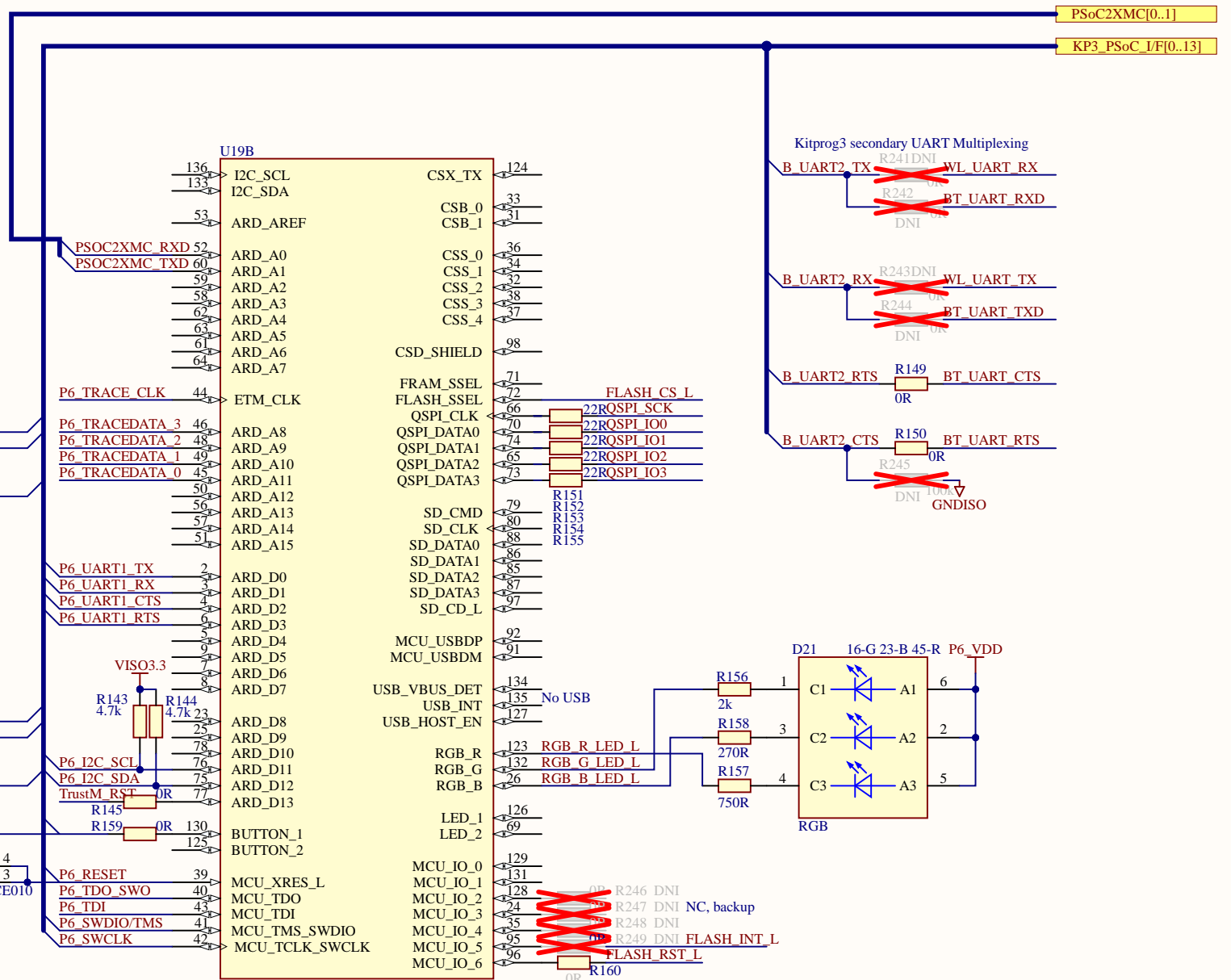
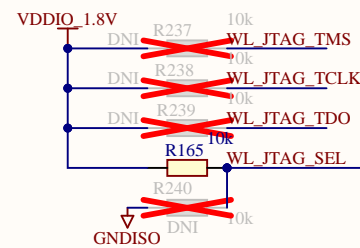

Trust M security card

Infineon Technologies AG
81726 München
Germany

Title: EVAL-XMC4800PSOC6M5
Variant: Default_Assembly
Size: A3
Document Name: 05_Connectivity with PSoC62+43012.SchDoc
Rev: V 1.0

Date: 2023/9/13 Time: 18:49:50
© 1999 - 2023 Infineon Technologies AG Sheet 6 of 13

06_Motor control section.SchDoc

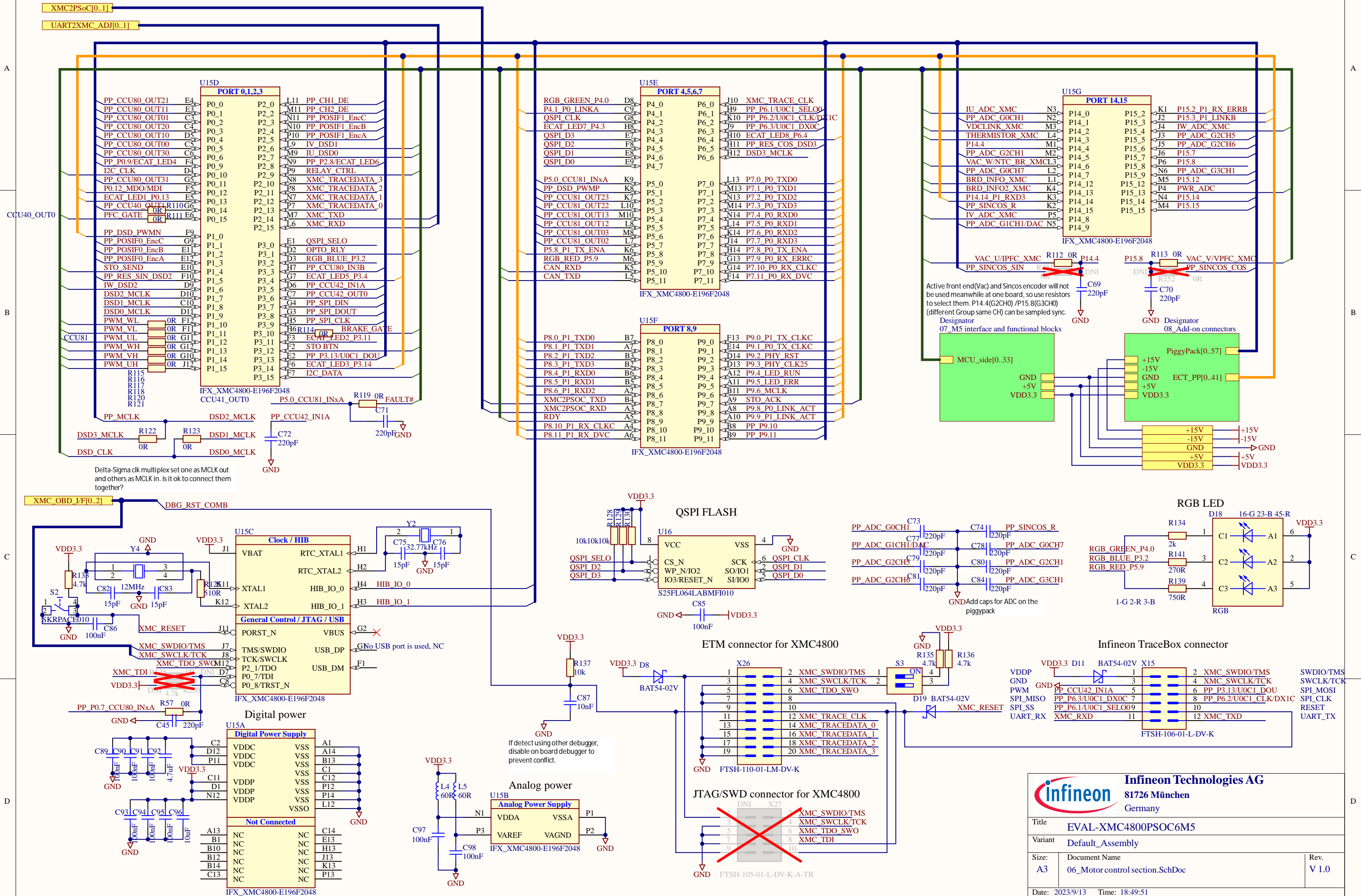

Infineon Technologies AG
 81726 München
 Germany

Title: EVAL-XMC4800PSOC6M5
 Variant: Default_Assembly
 Size: Document Name
 Rev: V 1.0

Date: 2023/9/13 Time: 18:49:51
 © 1999 - 2023 Infineon Technologies AG

Sheet 7 of 13

07_M5 interface and functional blocks.SchDoc

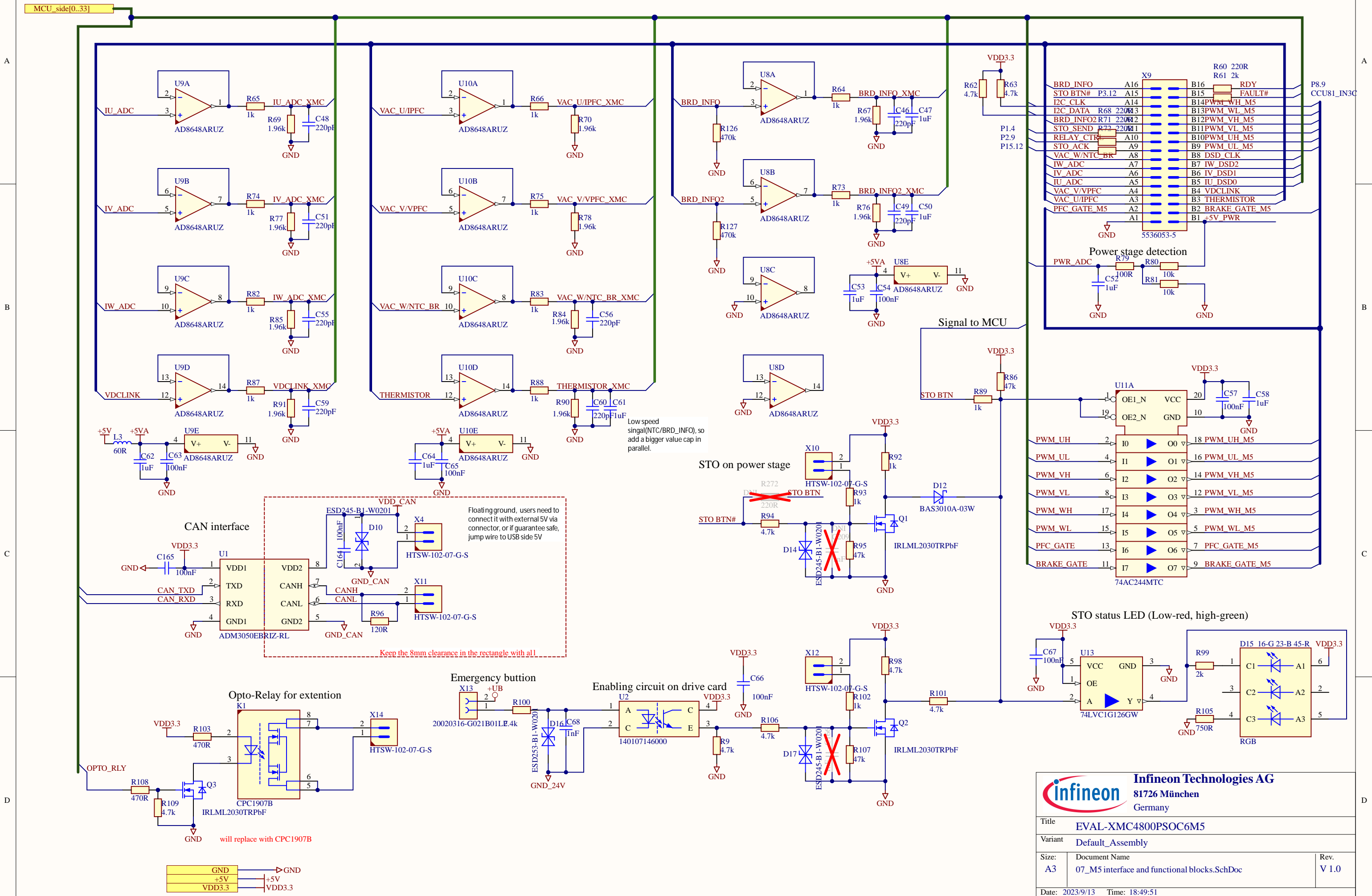

Infineon Technologies AG	
81726 München Germany	
Title	EVAL-XMC4800PSOC6M5
Variant	Default_Assembly
Size:	Document Name
A3	07_M5 interface and functional blocks.SchDoc
Date: 2023/9/13	Time: 18:49:51
© 1999 - 2023 Infineon Technologies AG	Sheet 8 of 13

08_Add-on connectors.SchDoc

Add-on connectors for extensions on EtherCAT and others

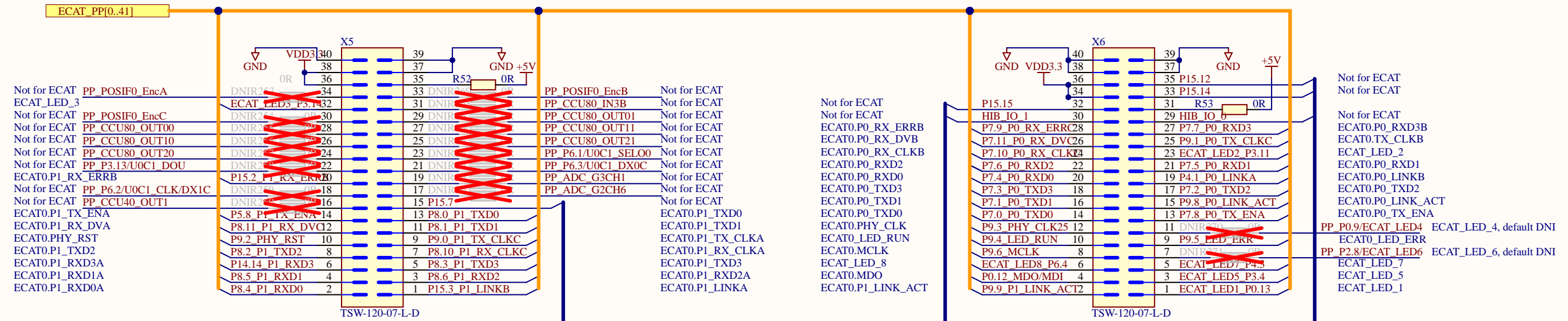

Add-on connectors for extensions on encoder and others

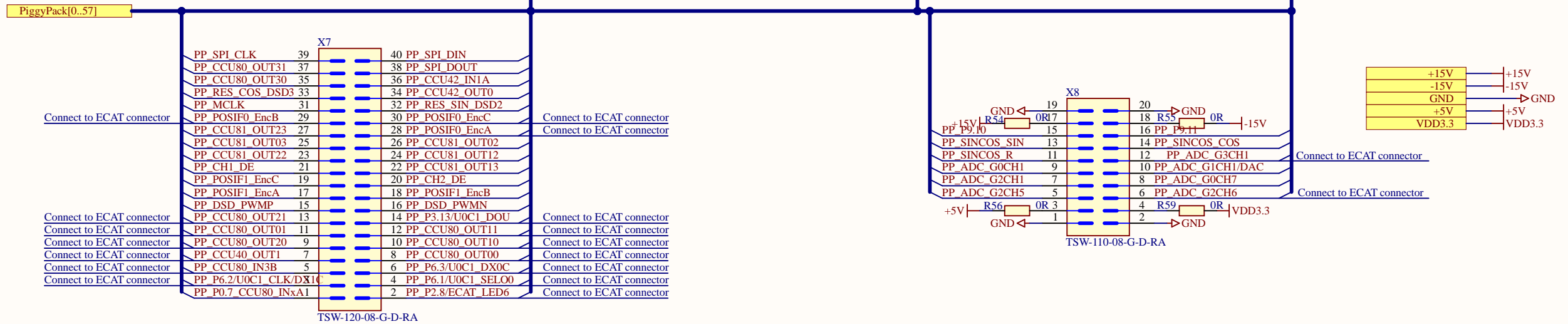

TSS-120-04-T-D-RA/TSS-110-04-T-D-RA or DC3-2.54-64PL is an alternative choice

Infineon Technologies AG 81726 München Germany	
Title	EVAL-XMC4800PSOC6M5
Variant	Default_Assembly
Size: A3	Document Name: 08_Add-on connectors.SchDoc
Rev. V 1.0	
Date: 2023/9/13	Time: 18:49:52
© 1999 - 2023 Infineon Technologies AG	
Sheet 9	of 13

09_On board debugger(OBD).SchDoc

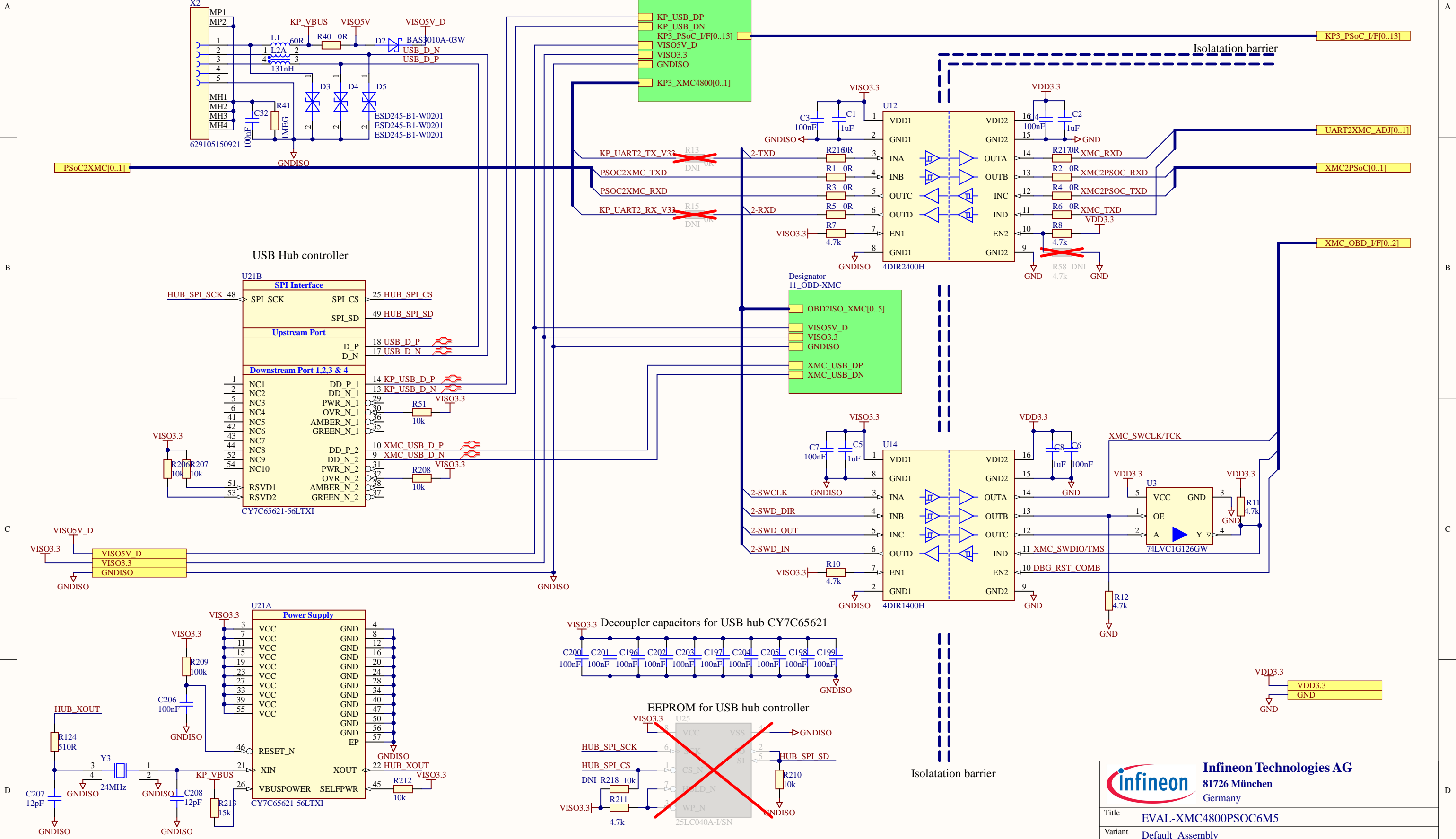

		Infineon Technologies AG 81726 München Germany	
		Title: EVAL-XMC4800PSOC6M5 Variant: Default_Assembly	
Size: A3	Document Name: 09_On board debugger(OBD).SchDoc		Rev: V 1.0
Date: 2023/9/13 Time: 18:49:52 © 1999 - 2023 Infineon Technologies AG		Sheet 10 of 13	

10_OBD-PSOC.SchDoc

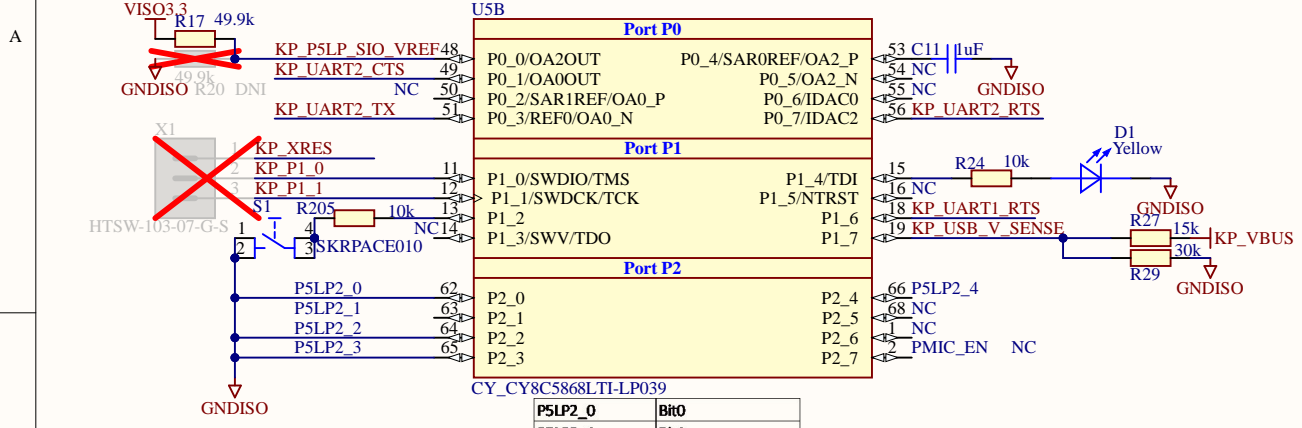

P5LP2_0	Bit0
P5LP2_1	Bit1
P5LP2_2	Bit2
P5LP2_3	Bit3
P5LP2_4	Bit4

Note: ID=0x0D, GND is read as binary "1" and floating as "0".

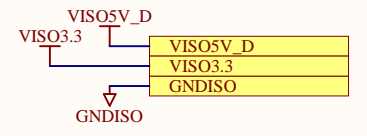
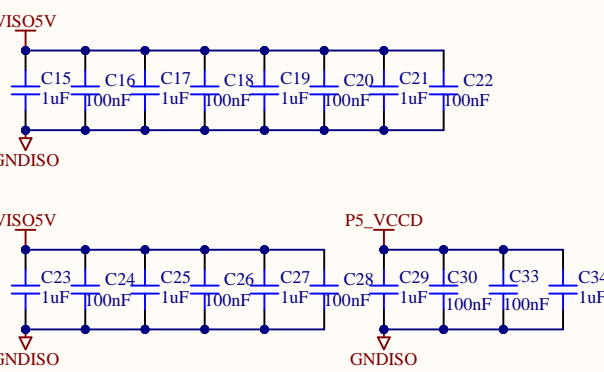
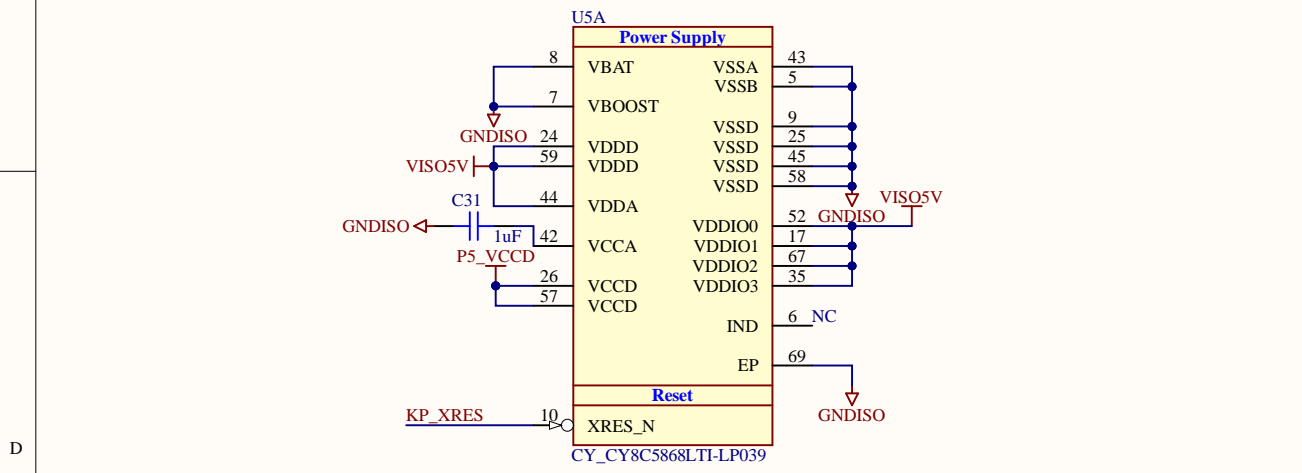
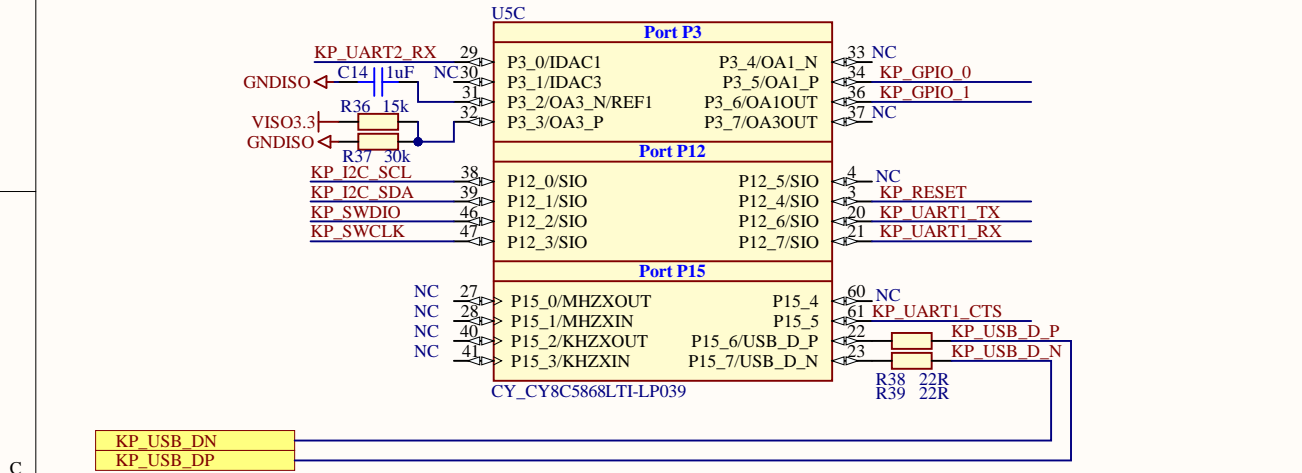
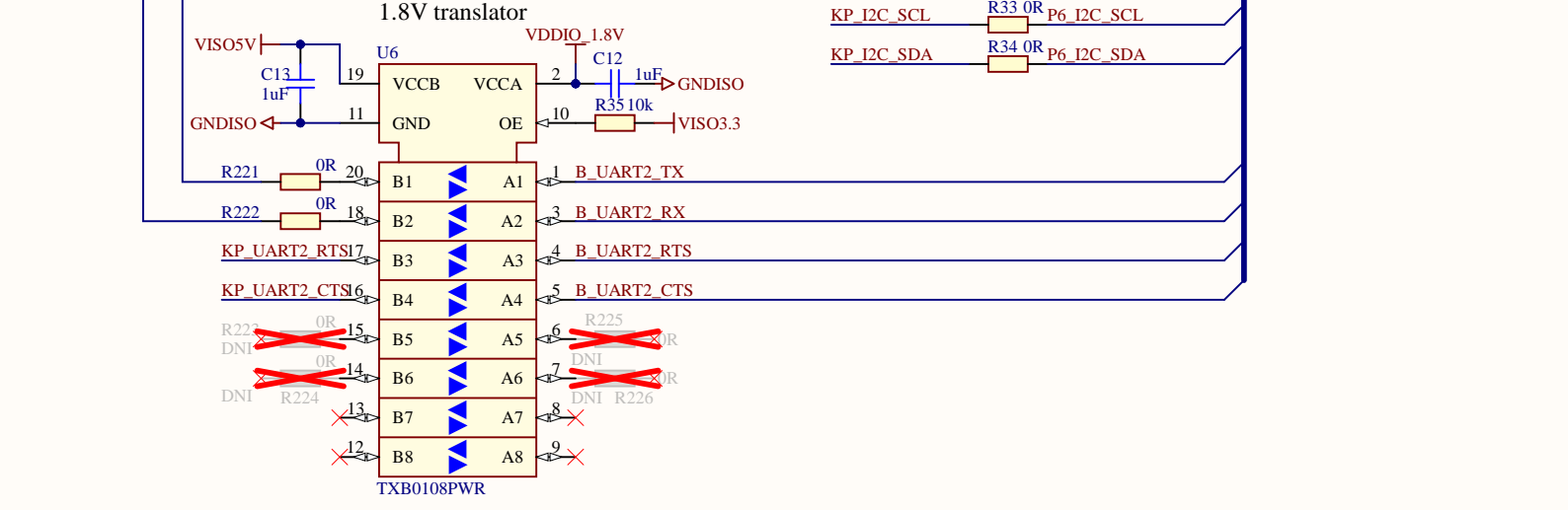
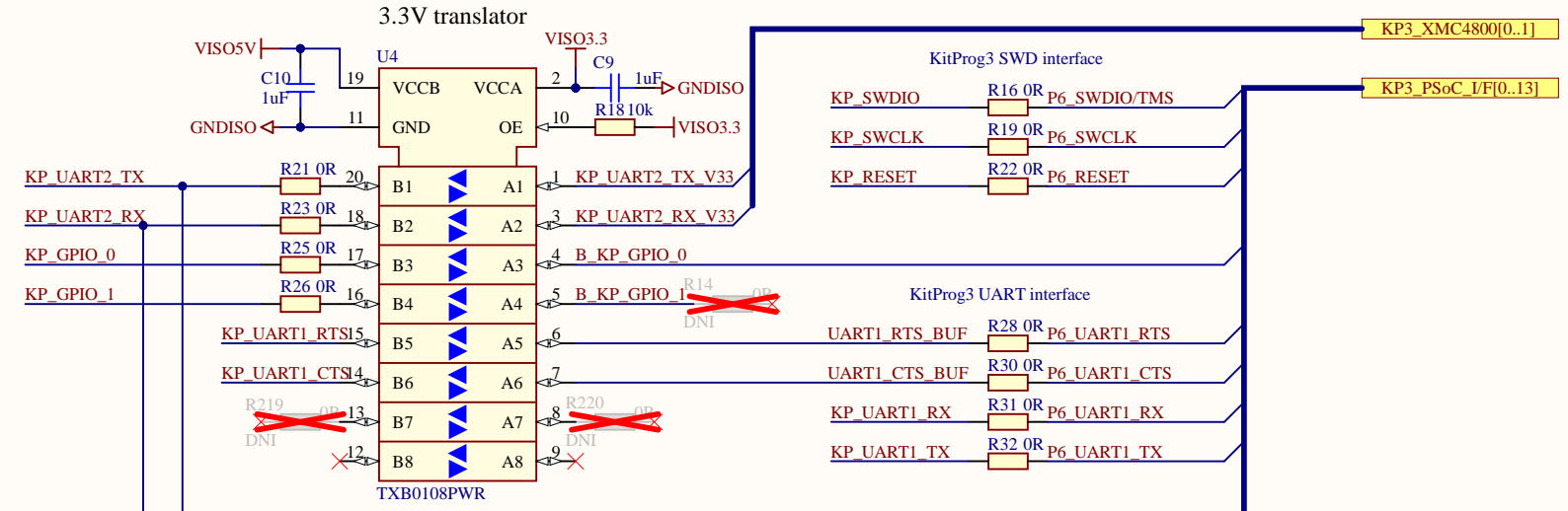

		Infineon Technologies AG 81726 München Germany	
		Title	EVAL-XMC4800PSOC6M5
Variant	Default_Assembly		
Size:	Document Name	Rev.	
A3	10_OBD-PSOC.SchDoc	V 1.0	
Date: 2023/9/13 Time: 18:49:52			
© 1999 - 2023 Infineon Technologies AG		Sheet 11	of 13

11_OBD-XMC.SchDoc

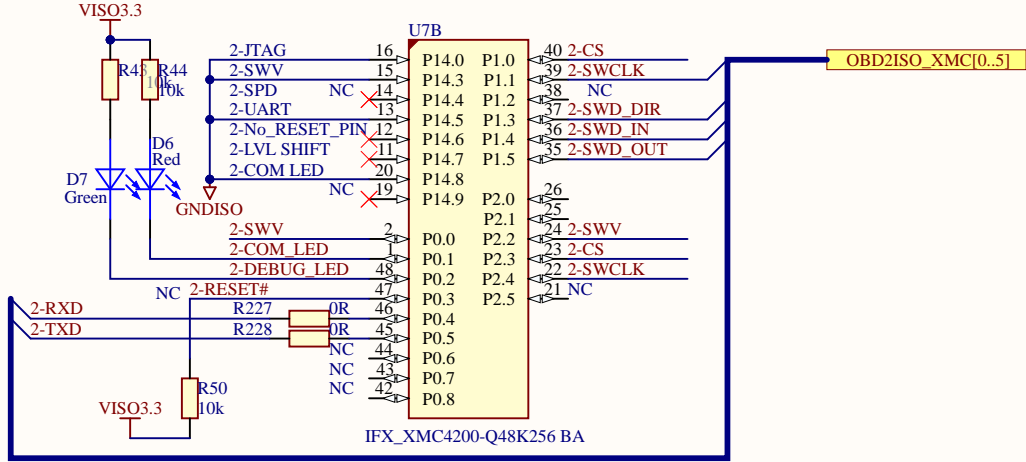
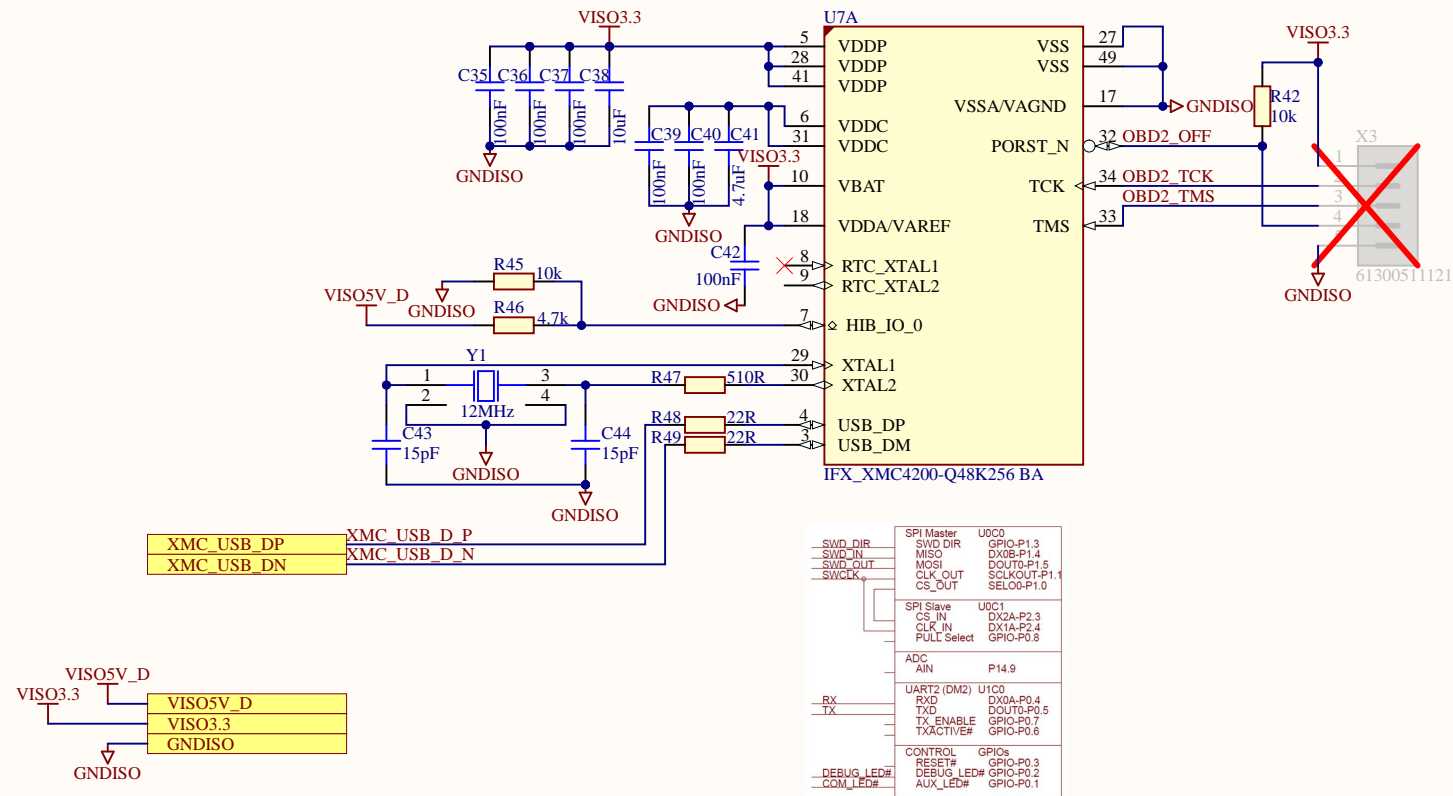

Infineon Technologies AG 81726 München Germany			
		Title EVAL-XMC4800PSOC6M5	
Variant Default_Assembly	Size: A3	Document Name 11_OBD-XMC.SchDoc	Rev. V 1.0
Date: 2023/9/13 Time: 18:49:52 © 1999 - 2023 Infineon Technologies AG		Sheet 12 of 13	

12_Power supply.SchDoc

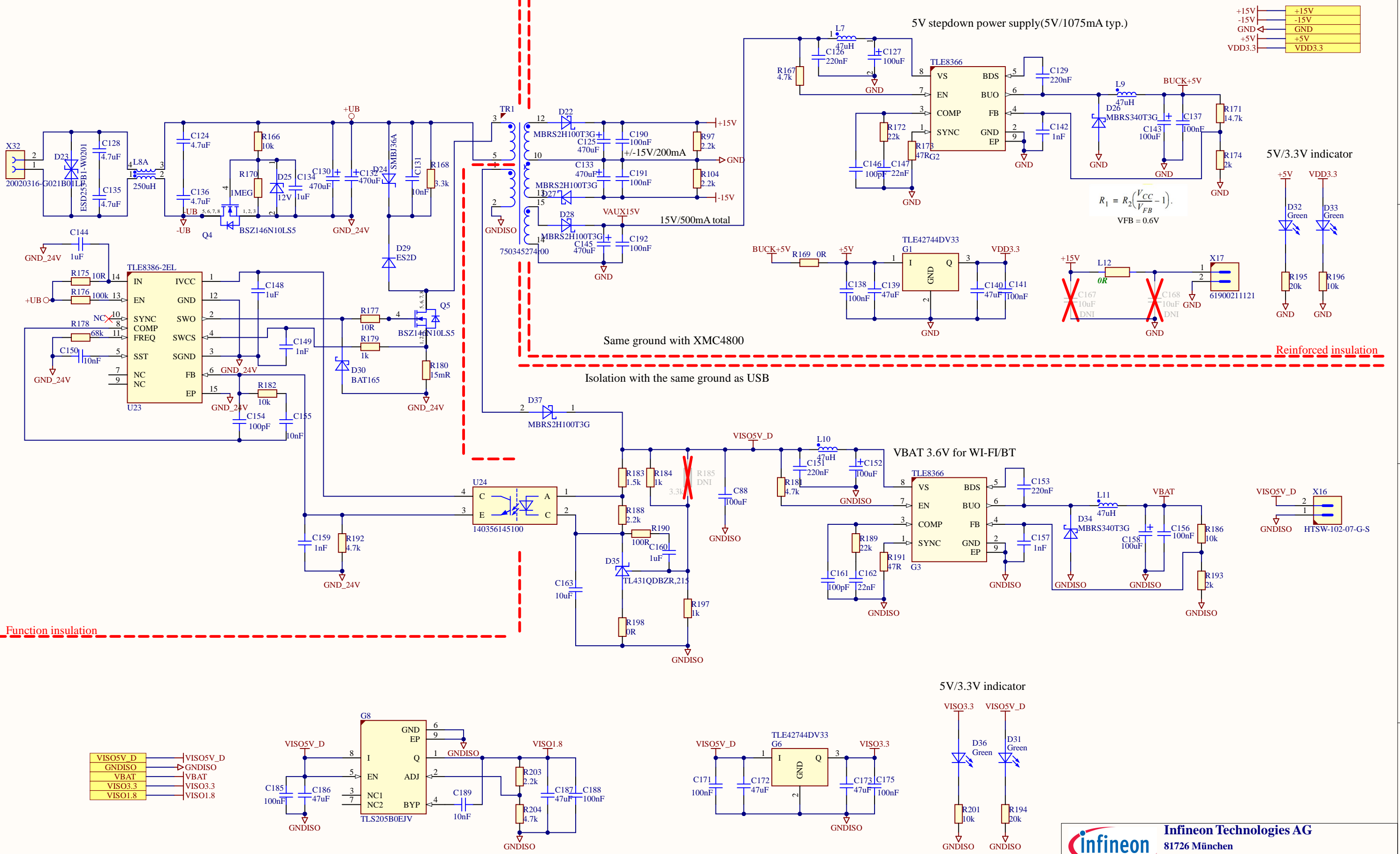

+15V	+15V
-15V	-15V
GND	GND
+5V	+5V
VDD3.3	VDD3.3

$$R_1 = R_2 \left(\frac{V_{CC}}{V_{FB}} - 1 \right)$$

VFB = 0.6V

VISO5V_D	VISO5V_D
GNDISO	GNDISO
VBAT	VBAT
VISO3.3	VISO3.3
VISO1.8	VISO1.8

		Infineon Technologies AG 81726 München Germany	
		Title: EVAL-XMC4800PSOC6M5 Variant: Default_Assembly	
Size: A3	Document Name: 12_Power supply.SchDoc	Rev. V 1.0	
Date: 2023/9/13 Time: 18:49:52		© 1999 - 2023 Infineon Technologies AG	
		Sheet 13	of 13