



Product Brief

Multimode Flyback Controller for LED

IRS2982S

Infineon's latest Multimode Flyback Controller IC for LED lighting is targeting mid-range to high-end LED drivers for outdoor, interior, office and industrial lighting applications. Its integrated startup cell together with CrCM, DCM and burst mode optimize overall efficiency from standby to 100 percent while keeping time to light less than 0.5 seconds and reducing the use of external components.

The benefits of the high voltage startup cell are:

- > Fast time to light < 0.5 s while maintaining > 90 percent efficiency
- > Eliminate external components for voltage dividing
- > CrCM/DCM/Burst modes enables wide range operation from standby to 100 percent
- > Key application is isolated flyback with CV mode and also capable of non-isolated flyback with CC/CV mode

Key features

- > High voltage startup cell (600 V)
- > CrCM/DCM operation
- > Burst mode capability
- > Accurate constant voltage/current regulation
- > Optimized one stage PFC + flyback
- > Cycle-by-cycle over-current protection
- > Open load over-voltage protection

Applications

Mid-range to high end LED drivers for:

- > Outdoor
- > Interior office
- > Industrial lighting

Typical connection for isolated flyback SMPS

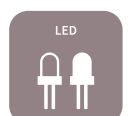
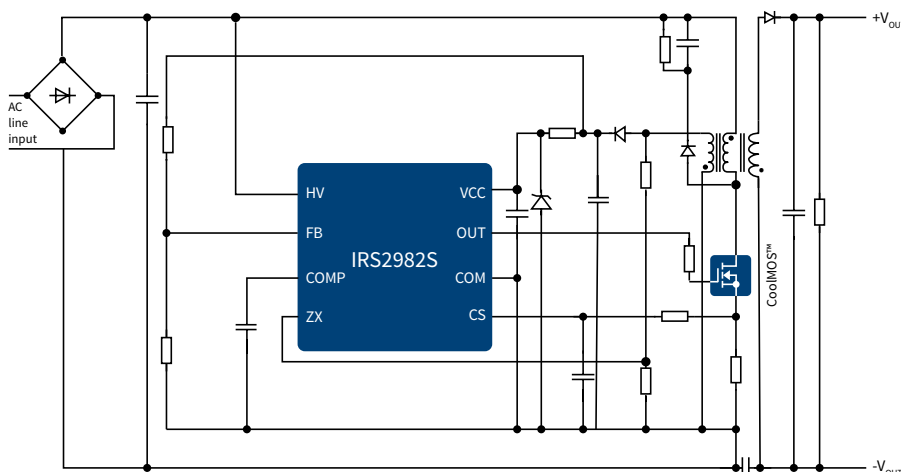

Multimode Flyback Controller for LED

IRS2982S

The IRS2982S is ideal for single stage converters with an unsmoothed DC bus to obtain high power factor and low line current total harmonic distortion (THD). It supports universal input and operates both at AC and DC inputs. And lastly, it also has over voltage and over current protection features.

IRXLED04 is the evaluation board for the IRS2982S with isolated flyback topology in constant voltage

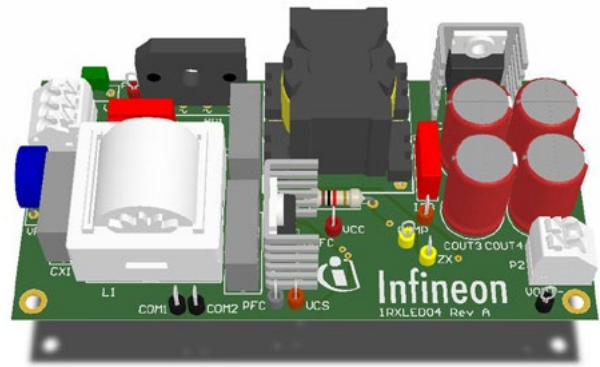

Product portfolio

Part number	Topology	Package	V _{HV} [V]	I _{o+} & I _{o-} [mA]	t _r & t _f [ns]
IRS2982S	Flyback	SO8N	600	200/400	0.9/1.2

Recommended 800 V CoolMOS™ CE for optimal performance

CoolMOS™ CE offers an outstanding price/performance ratio providing a competitive edge while being optimized for ease of use and efficiency in LED applications. The low R_{DS(on)} enables low conduction and switching losses. In addition it makes switching applications more efficient, more compact, lighter and cooler.

R _{DS(on)} [mΩ]	TO-220 FullPAK	TO-252 DPAK	TO-251 IPAK
2800		IPD80R2K8CE	IPU80R2K8CE
1400	IPA80R1K4CE	IPD80R1K4CE	IPU80R1K4CE
1000	IPA80R1K0CE	IPD80R1K0CE	IPU80R1K0CE
650	IPA80R650CE		
460	IPA80R460CE		
310	IPA80R310CE		

Published by
Infineon Technologies Austria AG
9500 Villach, Austria

© 2016 Infineon Technologies AG.
All Rights Reserved.

Please note!

THIS DOCUMENT IS FOR INFORMATION PURPOSES ONLY AND ANY INFORMATION GIVEN HEREIN SHALL IN NO EVENT BE REGARDED AS A WARRANTY, GUARANTEE OR DESCRIPTION OF ANY FUNCTIONALITY, CONDITIONS AND/OR QUALITY OF OUR PRODUCTS OR ANY SUITABILITY FOR A PARTICULAR PURPOSE. WITH REGARD TO THE TECHNICAL SPECIFICATIONS OF OUR PRODUCTS, WE KINDLY ASK YOU TO REFER TO THE RELEVANT PRODUCT DATA SHEETS PROVIDED BY US. OUR CUSTOMERS AND THEIR TECHNICAL DEPARTMENTS ARE REQUIRED TO EVALUATE THE SUITABILITY OF OUR PRODUCTS FOR THE INTENDED APPLICATION.

WE RESERVE THE RIGHT TO CHANGE THIS DOCUMENT AND/OR THE INFORMATION GIVEN HEREIN AT ANY TIME.

Additional information

For further information on technologies, our products, the application of our products, delivery terms and conditions and/or prices, please contact your nearest Infineon Technologies office (www.infineon.com).

Warnings

Due to technical requirements, our products may contain dangerous substances. For information on the types in question, please contact your nearest Infineon Technologies office.

Except as otherwise explicitly approved by us in a written document signed by authorized representatives of Infineon Technologies, our products may not be used in any life-endangering applications, including but not limited to medical, nuclear, military, life-critical or any other applications where a failure of the product or any consequences of the use thereof can result in personal injury.