

# ZYNQ UltraScale+ Zu07 Xilinx ZCU-104 Embedded Vision Reference Design

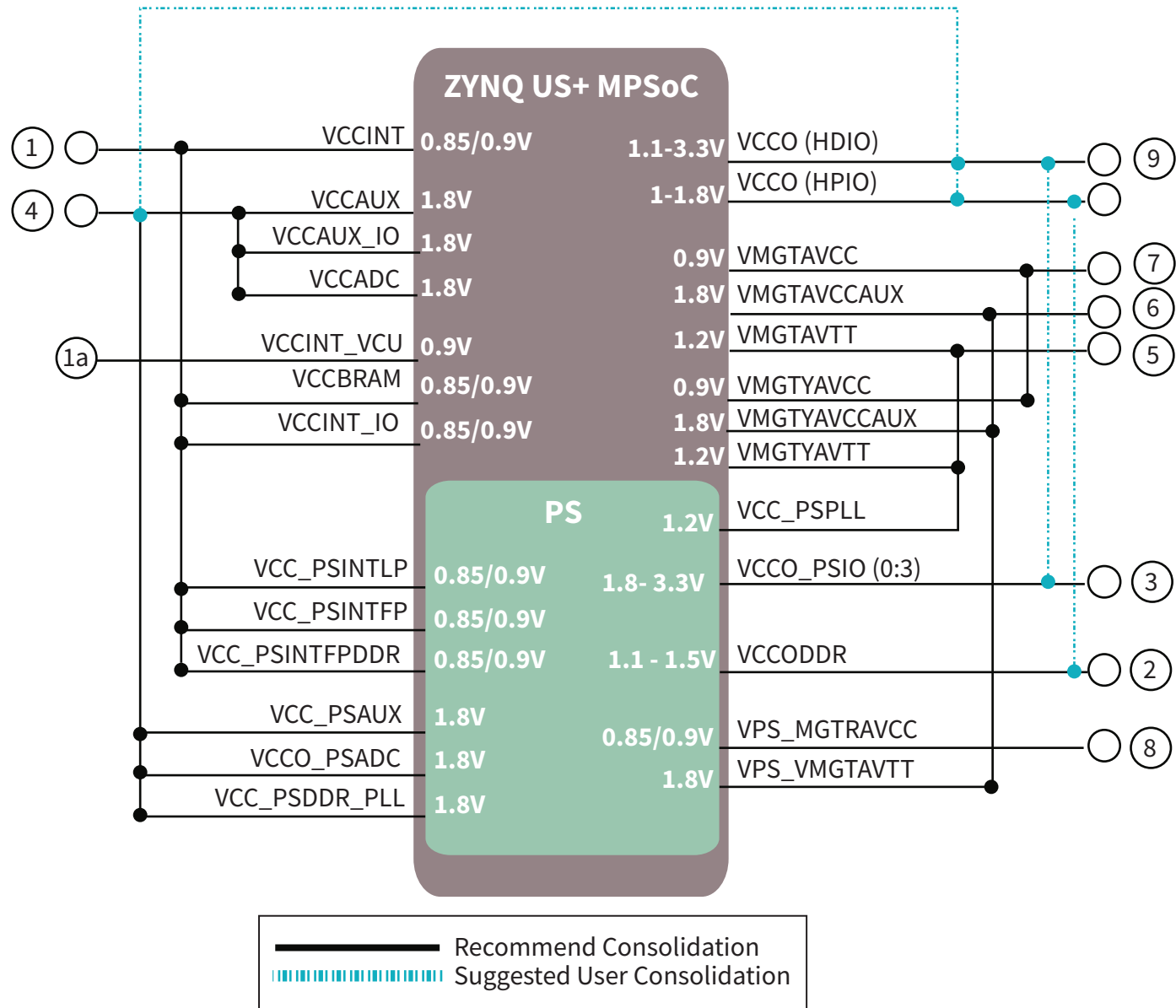

VIN = 12V

