

REV.	DESCRIPTION	ECN	DATE
C	INITIAL RELEASE	1120_ER6904	4-3-20

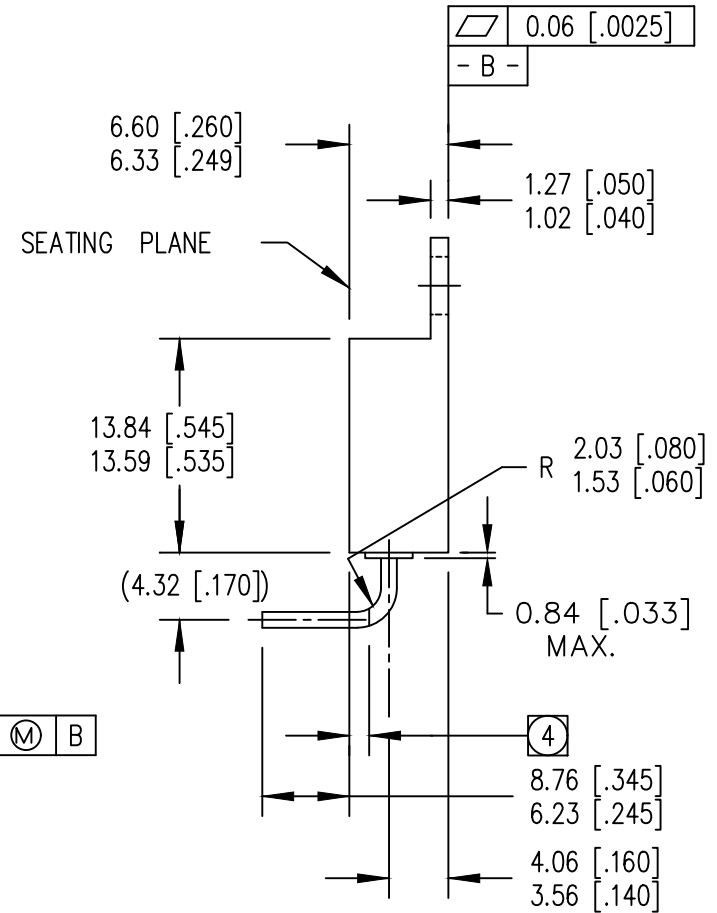
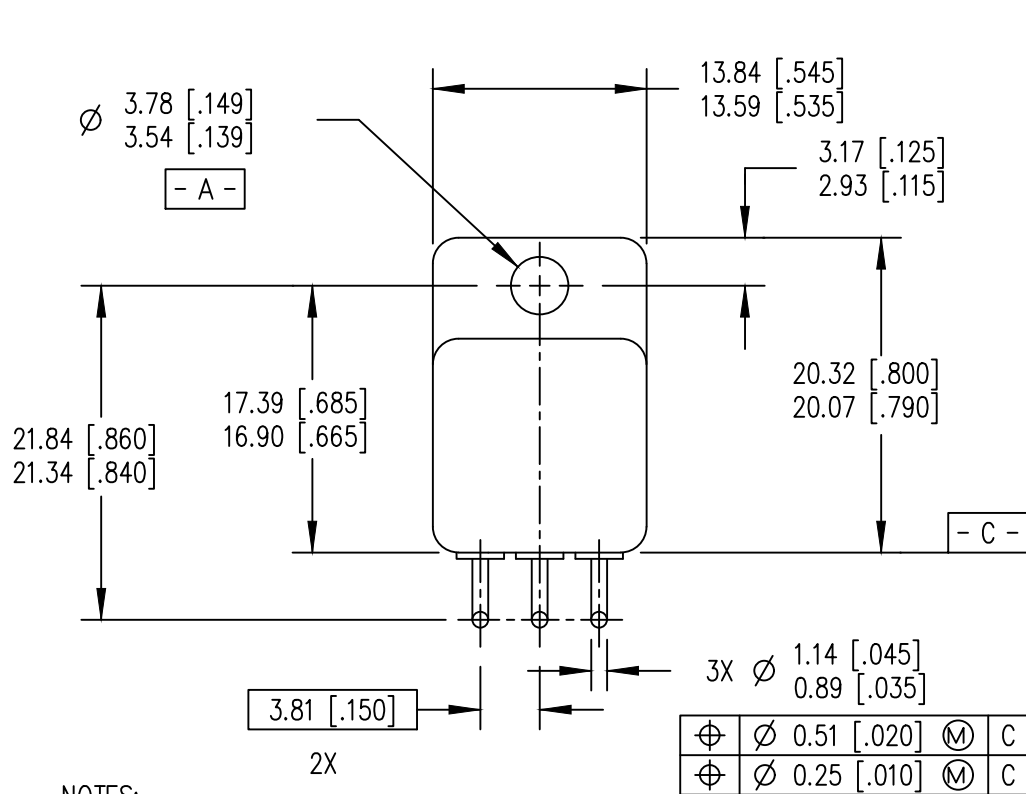

NOTES:

1. DIMENSIONING & TOLERANCING PER ANSI Y14.5M-1982.
2. DIMENSIONS ARE SHOWN IN MILLIMETERS [INCHES].
3. CONTROLLING DIMENSION: INCH.

④ LEADS ARE SOLDER DIPPED 1.27 [.050] MINIMUM BEYOND THE SEATING PLANE.

5. FORM LEADS USING AUTO LEAD BEND MACHINE (ES02526) WITH TO-254, 90° LEAD FORM UP FIXTURE.
6. STANDARD FINAL FINISH ON ALL TERMINALS IS SOLDER ALLOY 63%Sn 37%Pb.

IOR HiRel
An Infineon Technologies Company

TITLE: TO-254AA LEADFORM
90° UP, PACKAGE OUTLINE

DRAWING NO.
D100708G-WEB

REV C