

# NSMD

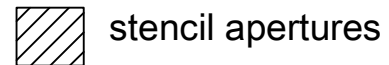
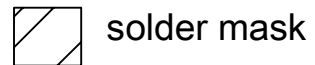
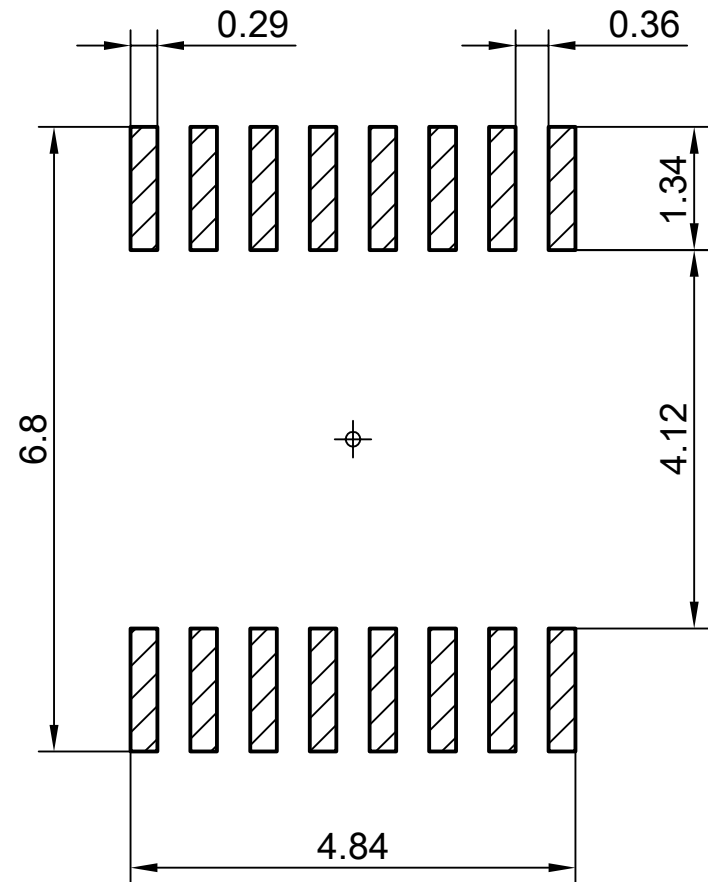
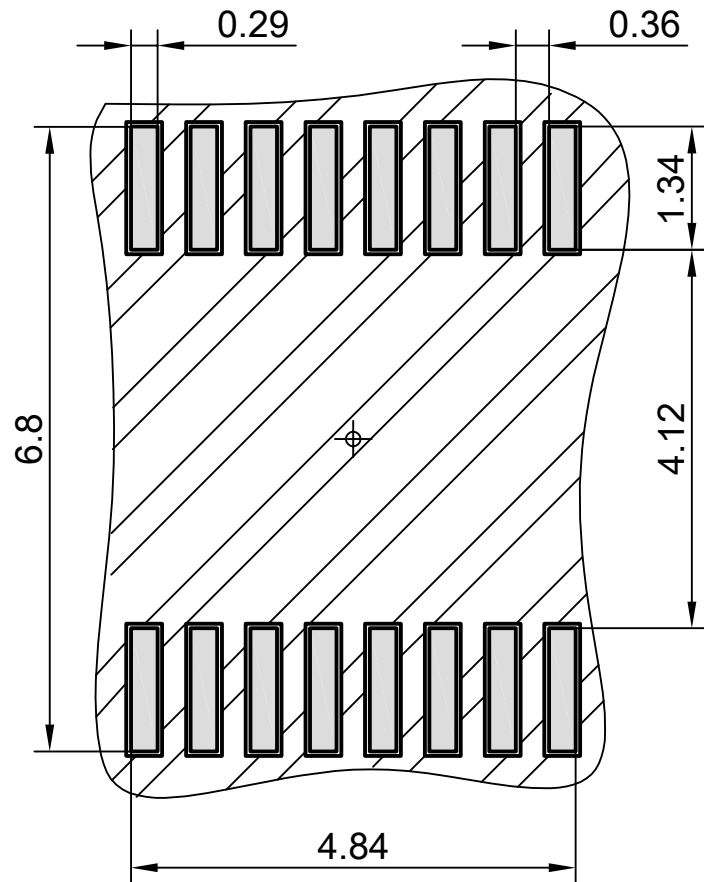

ALL DIMENSIONS ARE IN UNITS MM