

Bottom view

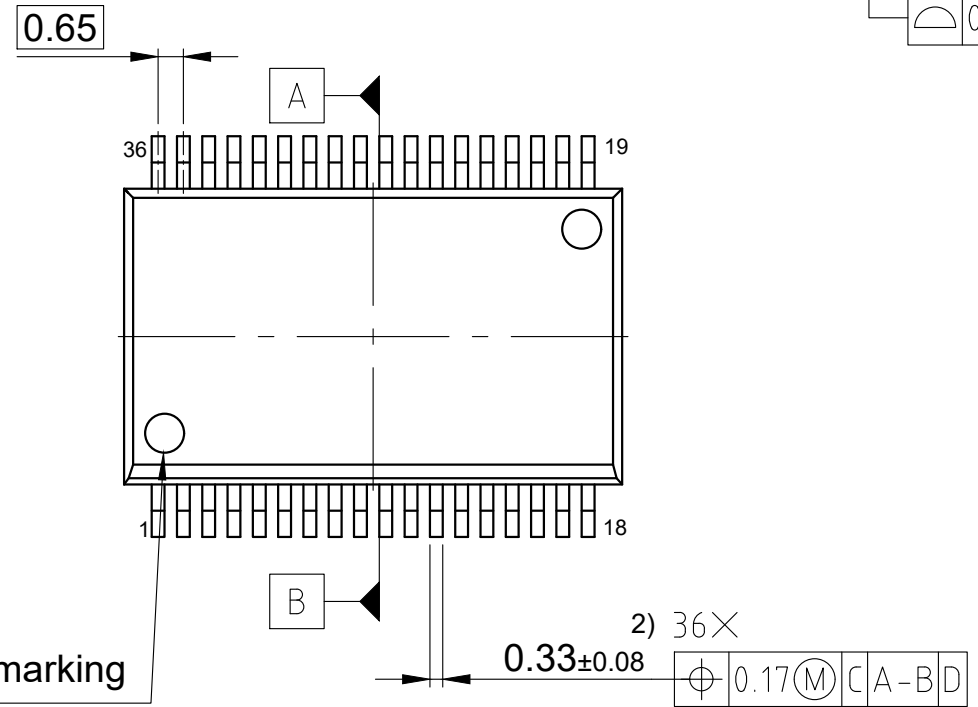
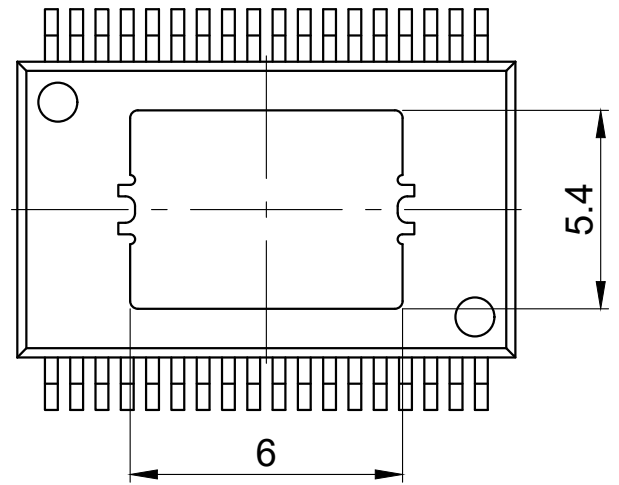

Pin1 marking

- 1) Does not include plastic or metal protrusion of 0.15 max. per side
 - 2) Does not include dambar protrusion of 0.05 max. per side
 - 3) Distance from leads bottom (=seating plane) to exposed die pad
 - 4) Excluding the mold flash allowance of 0.3mm max.per side
- All dimensions are in units mm

The drawing is in compliance with ISO 128-30, Projection Method 1 []