

Package Outline

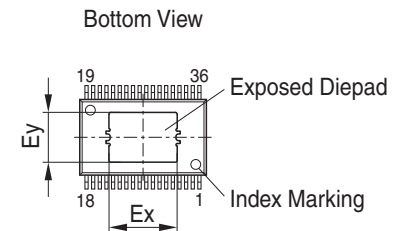
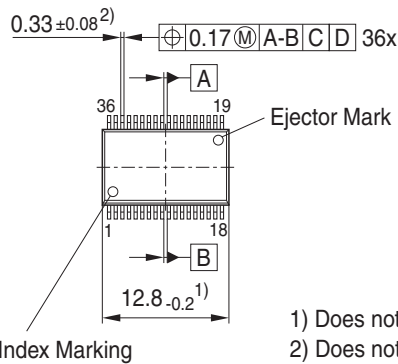
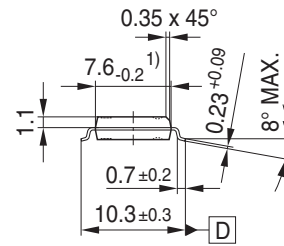
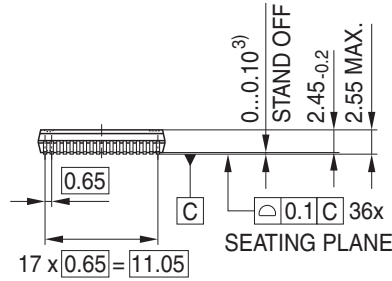

- 1) Does not include plastic or metal protrusion of 0.15 max. per side
- 2) Does not include dambar protrusion of 0.05 max. per side
- 3) Distance from leads bottom (= seating plane) to exposed diepad

Exposed Diepad Dimensions		
Package	Ex	Ey
PG-DSO-36-24, -38, -41, -42, -51, -53, -77, -79	7.0	5.1
PG-DSO-36-50, -80	6.0	5.4
PG-DSO-36-38, -75	5.2	4.6

Excluding the mold flash allowance of 0.3 max per side

Foot Print

Soldering Type: Reflow Soldering

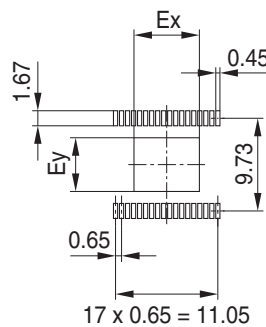

Marking Layout

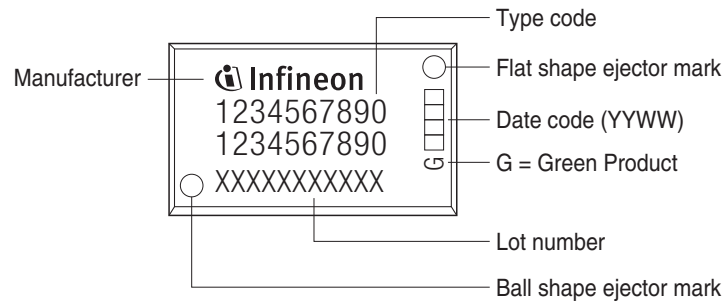

Tape and Reel

Reel \varnothing 330 mm: 1.000 Pieces/Reel
 Reels/Box: 1

