

One Cycle Control IC Simplifies PFC Designs

Ron Brown, Marco Soldano
AC-DC Applications Group
International Rectifier Corp.
101 N. Sepulveda Blvd
El Segundo, CA, 90245 USA

As presented at APEC 05

Abstract: This paper presents an implementation of the One Cycle Control (OCC) method, which simplifies the design procedure for continuous conduction mode PFC converters. The traditional “multiplier” based methods are reviewed and compared to the One Cycle Control technique. A direct comparison of “step by step” design procedure for both solutions is presented, as well as experimental results which demonstrate that the benefits of the OCC method impose no sacrifice in performance.

I. INTRODUCTION

High performance, Continuous Conduction Mode (CCM) Power Factor Correction is typically realized by means of a boost converter controlled by a high performance control IC, the heart of which is an analog multiplier. A control technique known as One Cycle Control (OCC) contends reductions in complexity, cost, design time, and PCB real estate, without a sacrifice in performance.

Claims of this nature seem counter intuitive to the seasoned designer, who has invariably learned through first hand experience, that there is no such thing as a “free lunch”. The objective of this paper is to therefore discern the validity of these claims by comparing the two solutions, side by side, in terms of design of the control circuit and overall performance.

II. THE ANALOG MULTIPLIER PFC

Typical PFC implementation for medium to high power systems is CCM, fixed frequency, multiplier based approach. There are a number of industry standard controllers available on the market to provide this type of control function [10].

Due to multiplier circuit and the input voltage sensing required, this approach is usually complicated and requires quite a few external components to realize the control design. The heart of the multiplier control technique is the analog multiplier. The multiplier is used to create the reference to be compared against a fixed ramp at the inputs to the PWM comparator.

The reference signal is derived from a combination of sensed values of the input voltage, the output voltage, and the inductor current all supplied to the multiplier inputs, then processed by the multiplier in order to create the reference signal.

The multiplier based approach is the industry standard for control of high performance CCM boost converters for power

factor correction applications, and has been for the past two decades.

III. THE ONE CYCLE CONTROL PFC

The “One Cycle Control” technique was developed as a general pulse width modulator control method [1]. It is also known as the integration-reset technique wherein the key element is the resettable integrator.

This control method was developed to achieve large signal, non-linear control of switching converters: pulsed, non-linear systems utilizing pulsed, non-linear control should be more robust, have faster transient response and better input disturbance rejection than the same system operating under linear control [2][3][4].

The “One Cycle Control” uses the pulsed and non-linear nature of switching converters to achieve instantaneous control of the average value of the switched voltage or current. This technique is designed to control the duty cycle in real time such that in each cycle the average of the chopped waveform is exactly equal to the control reference.

This control method provides a unified control technique adaptable to various topologies for both leading edge and trailing edge modulation by simply changing the control and reference inputs.

One such application is PFC converter control wherein the duty cycle of the boost converter is modulated to force the input to appear purely resistive [1].

With OCC, the output of the voltage error amplifier is integrated over the switching cycle to produce a ramp voltage which is compared to a voltage reference generated by a combination of the sum of the inductor current and the error voltage. This is then compared at the PWM comparator input to determine the duty cycle of the boost converter power switch.

A key aspect of the OCC control method is the fact that this ramp created by the integrator circuit is reset at the end of each switching cycle and the ramp starts again from zero at the beginning of the subsequent cycle. Accordingly, this method is aptly termed, OCC, or “One Cycle Control”.

IV. CONTROLLER CORE COMPARISON

The key differences between a multiplier based solution and the OCC solution is the manner in which the current

reference is generated, and the signals present at the PWM input.

The multiplier based approach utilizes the analog multiplier to create the current programming signal. This is achieved by multiplying the rectified line voltage input signal by the output signal of the voltage error amplifier. The output of the multiplier is therefore the current programming signal.

This signal has the shape of the input voltage, and average amplitude proportional to the output of the output voltage error amplifier, which controls the output voltage.

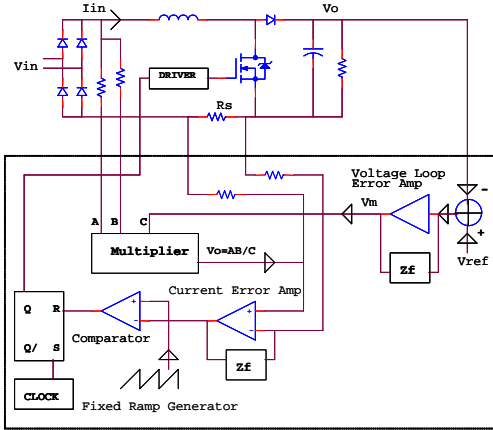

Figure 1 - Multiplier Control Core

This current programming signal is summed with a current proportional to the inductor current and introduced at the non inverting input of the current amplifier. The output of the current amplifier compares to a fixed oscillator ramp and duty cycle of the power switch is modulated accordingly.

The One Cycle Control method, the operation of which is described in detail in the previous paragraph, uses no analog multiplier, no input voltage sensing, and no fixed oscillator ramp. The output of the error amplifier integrated over a switching cycle to generate a variable slope ramp. The variable ramp is compared with the error voltage subtracted of the current sense signal, to generate the PWM gate drive.

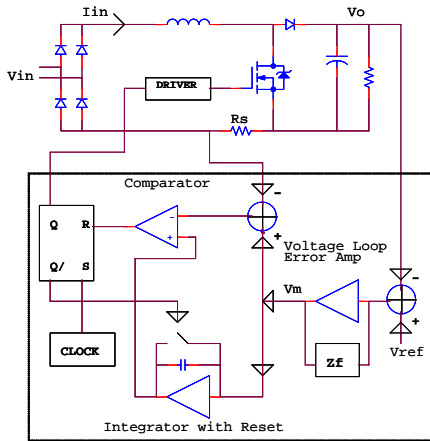

Figure 2 - OCC Control Core

Despite this significant dissimilarity in control methodology, the functionality and performance of the two

distinct approaches are essentially the same. Once again, the reduced complexity and the fewer required external component of the One Cycle Control method, make it somewhat difficult to envision the possibility of achieving equivalent performance in comparison to industry standard multiplier based solutions.

V. DESIGN PROCEDURE

The design criterion for the power stage is essentially indistinguishable between the two, in terms of the selected approach for the control circuit design.

The control circuit design is another matter which is summarized in the table below in terms of the dissimilar design requirements between the two control solutions.

Table 1 - Summary of design steps for the two controls

Design Parameter	Analog Multiplier	OCC
I_{AC} Input current reference	✓	✗
V_{FF} feed forward filter	✓	✗
Multiplier Output	✓	✗
Current Amp Comp	✓	✗
Soft Start	✓	✓
Output Voltage Sensing & Comp	✓	✓
Current Sensing	✓	✓

The analog multiplier design requires some additional design steps that the OCC method avoids simply by the nature of the control method itself. These points are summarized below, please refer to Fig. 4 which shows a typical schematic for a multiplier based design.

A. AC Current Reference

In the multiplier case the AC line needs to be sensed to generate the current reference, thru the I_{AC} signal. This design step is not particularly complex, requiring a simple scaling factor. This signal is not required for the OCC since the reference is reconstructed out of the current sense signal.

B. Feed Forward Filter Design

V_{FF} - A single pole filter is designed at pin 8. Current from I_{AC} is mirrored internally to this node to produce an input voltage feed forward signal. Proper filtering of 120Hz ripple at this node is required to reduce distortion. Once again this signal is not required for the OCC.

C. Multiplier Output Programming

Multiplier output current must be setup to match the maximum current through the sense resistor to the maximum multiplier current.

D. Current Amplifier Compensation

Current amplifier requires external compensation network to operate in the average current mode. This is independent from the control type. The OCC allows a stable peak current mode operation, making current loop compensation unnecessary.

Soft Start, output voltage sensing and current sensing are identical in the two cases.

The differences in the design requirements for the two solutions yields a difference in component count as outlined in Table 2, while the typical schematics for the two implementations are shown in Figure 3 and Figure 4.

Table 2 - Component Count

Passives	Multiplier	OCC
Resistors	18	11
Capacitors	8	4

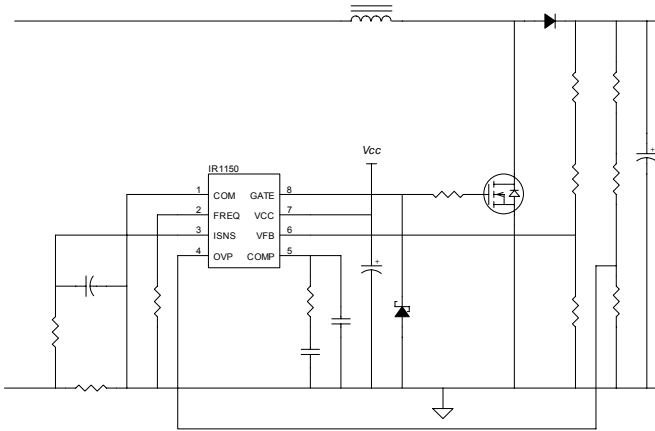

Figure 3 - OCC typical schematic

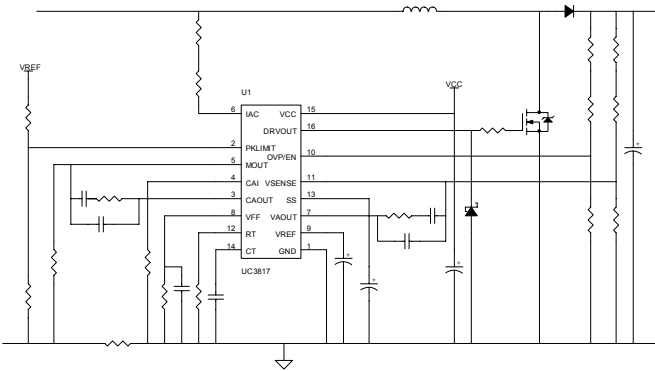

Figure 4 - Multiplier typical schematic

The OCC based design provides a significant reduction in component count for the control circuit when compared to a multiplier based solution. This translates into a reduction in bill of material cost and required PCB space for the control section and reduces the number of design steps required to realize the design.

VI. EXPERIMENTAL RESULTS

Two converters, each operated at 250W maximum output power, one utilizing an analog multiplier based controller while the other is controlled with “One Cycle Control” based IC, have been compared. Tests were conducted at room ambient temperature following a sufficient stabilization period of 30 minutes at 90VAC and 250W load.

The analog multiplier board is a reference design from Unitrode/TI, based on the UCC3817 controller chip shown in Figure 5.



Figure 5 - Multiplier Based 250W Demo Board

The OCC reference board is built around the new IR1150 PFC chip and is shown in Figure 6. Both boards are running at fixed frequency of 100kHz and same value of the boost inductor, so to allow the same amount of current ripple.

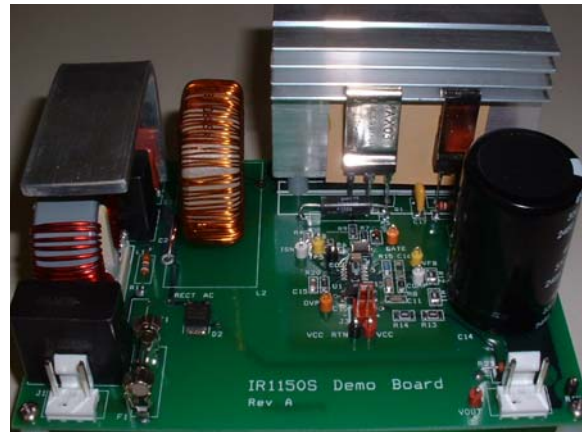

Figure 6 - OCC Based 300W Demo Board

The two boards have also been modified to match the EMI filters and make a fair comparison.

A. Power Factor

Power factor, harmonic components and ac line current waveforms have been compared for the two converters across line and load variation.

For the power factor comparison the EMI filters and high frequency film capacitors have been removed from both demo boards in order to compare performance without the influence of input filtering. The results show a very similar performance in for the two realizations as shown in Figure 7 and Figure 8.

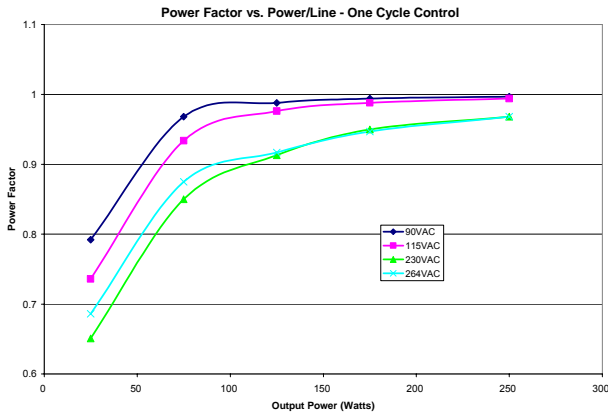

Figure 7 - Power Factor for One Cycle Control

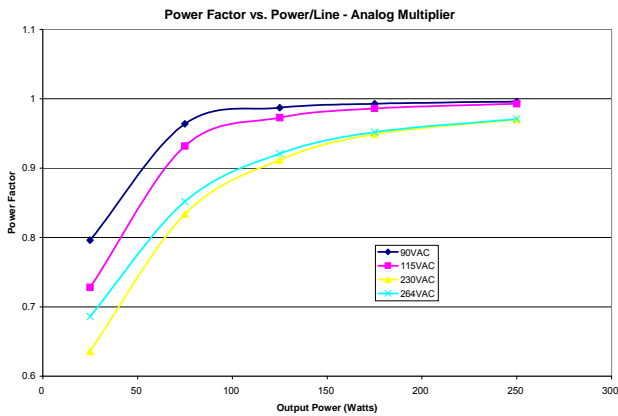

Figure 8 - Power Factor for Analog Multiplier Control

B. Harmonic Components and waveforms

It should be noted here that recent amendment of the EN61000-3-2 standard for harmonic regulation, limits the Class D classification of electronic equipment to personal computers, PC monitors, and television receivers [7].

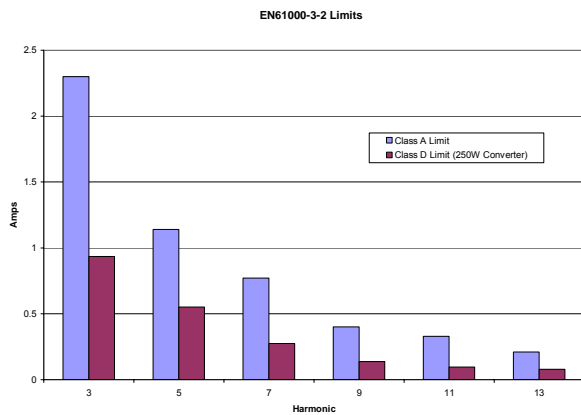

Figure 9 - EN61000-3-2 Limits

A good percentage of electronic devices previously classified as Class D, are now subject to the more relaxed requirements of Class A. Figure 5 shows the differences in

the requirements for Class A and Class D for a 250W application.

Results of measured harmonic content for the two demo boards are shown in Figure 10 and Figure 11. It is evident that both of the demo boards tested easily meet the harmonic content requirement of the EN61000-3-2 standard, with margin, both Class A and Class D.

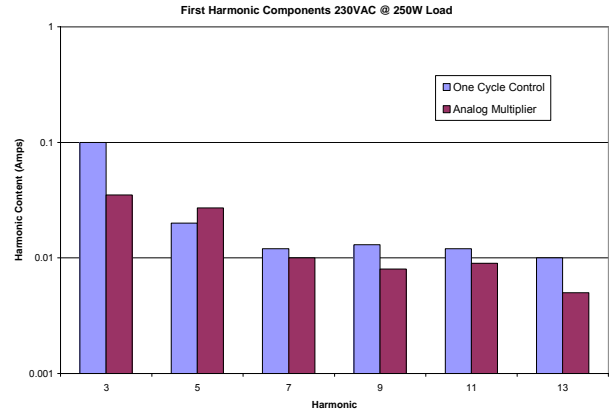

Figure 10 - 230V ac line harmonic components

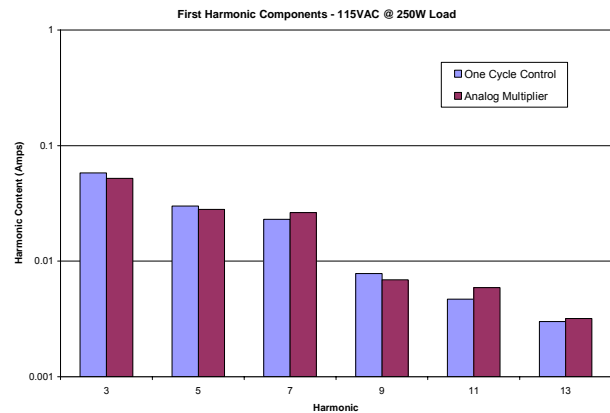

Figure 11 - 115V ac line harmonic components

Figure 12 thru Figure 15 show the ac line voltage and current waveforms for the 2 implementations.

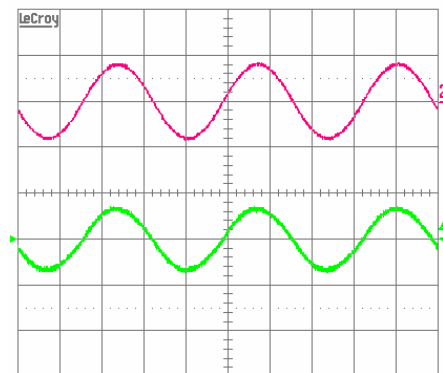

Figure 12 - Analog Multiplier @ 115VAC/250W

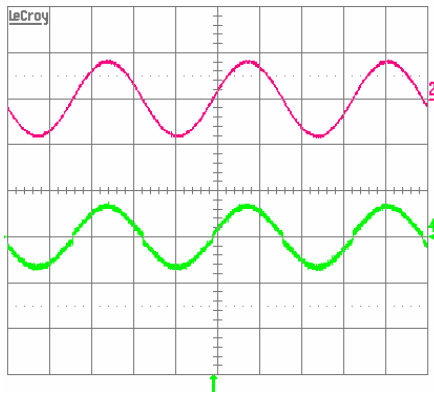

Figure 13 -One Cycle Control @ 115VAC/250W

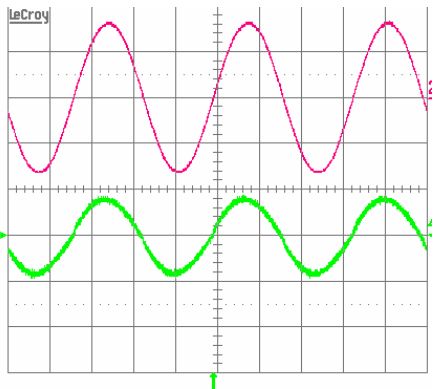

Figure 14 - Analog Multiplier @ 230VAC/250W

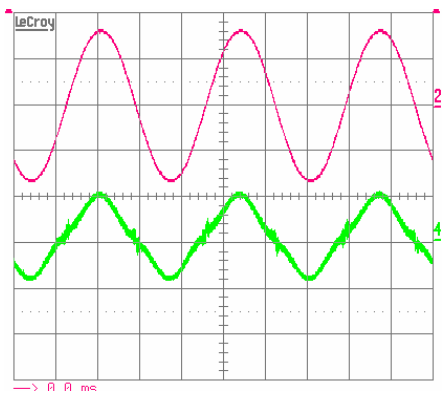

Figure 15 - One Cycle Control @ 230VAC/250W

VII. CONCLUSIONS

The One Cycle Control circuit provides performance equivalent to that of the analog multiplier based control circuit. Both solutions provide for high performance power

factor correction and harmonic current reduction in order to conform to requirements of EN61000-3-2 standards.

While both solutions provide the means to achieve the desired performance, they employ vastly dissimilar control techniques in order to do so. The One Cycle Control based design requires a lower component count thereby having a direct impact on BOM cost. Fewer control circuit components equates to less real estate required on the printed circuit board which, in addition to the reduction of BOM cost, reduces manufacturing cost while freeing up the valuable pcb space.

The design time is reduced with the One Cycle Control solution due to the fact that there are fewer design elements to contend with. In conclusion, there apparently is such a thing as a free lunch, compliments of the novel One Cycle Control for PFC.

REFERENCES

- [1] Z. Lai, Keyue Smedley. "A Family of Power Factor Correction Controllers". APEC '97. New York. IEEE 1997
- [2] K. Smedley. S. Cuk. "One Cycle Control of Switching Converters". 22nd Annual IEEE Power Electronics Specialists Conference (Cat. No.91CH3008-0), Cambridge, MA, 1991. pp. 888-96. See also US patent 5,278,490 and IEEE Transactions on Power Electronics, Nov. 1995, Vol. 10, No. 6, P625-633.
- [3] K. Smedley and Slobodan Cuk "Dynamics of One-Cycle Controlled Cuk Converters", IEEE Transactions on Power Electronics, Nov. 1995, Vol. 10, No. 6, P634-639.
- [4] K. Smedley: "One-Cycle Controlled Switching Circuit" US Patent # 5,278,490, Jan, 1994.
- [5] P. Todd. "UC3854 Controlled Power Factor Correction Circuit Design". Unitrode Application Note
- [6] M. O'Laughlin. "UCC3817 BiCMOS Power Factor Preregulator Demonstration Board" SLUU077C September 2000
- [7] T. Brooks. "Specifying the Best PFC Topology for Your Power Supply". Analog Zone May 04
- [8] Lai Z.; Smedley, K.M.; "A family of continuous-conduction-mode power-factor-correction controllers based on the general pulse-width modulator", IEEE Transactions on Power Electronics, Volume: 13, Issue: 3, May 1998, Pages:501 - 510
- [9] International Rectifier, IR1150S data sheet
- [10] Unitrode, UCC3817 data sheet
- [11] K. Smedley - US Patent 5,278,490 – California Institute of Technology