

AN2007-06

MA300E12 / MA300E17 – Module Adapter Board for PrimePACK™ IGBT Modules

IFAG IMM INP M AE

Edition 2010-05-07

Published by

Infineon Technologies AG

59568 Warstein, Germany

© Infineon Technologies AG 2010.

All Rights Reserved.

Attention please!

THE INFORMATION GIVEN IN THIS APPLICATION NOTE IS GIVEN AS A HINT FOR THE IMPLEMENTATION OF THE INFINEON TECHNOLOGIES COMPONENT ONLY AND SHALL NOT BE REGARDED AS ANY DESCRIPTION OR WARRANTY OF A CERTAIN FUNCTIONALITY, CONDITION OR QUALITY OF THE INFINEON TECHNOLOGIES COMPONENT. THE RECIPIENT OF THIS APPLICATION NOTE MUST VERIFY ANY FUNCTION DESCRIBED HEREIN IN THE REAL APPLICATION. INFINEON TECHNOLOGIES HEREBY DISCLAIMS ANY AND ALL WARRANTIES AND LIABILITIES OF ANY KIND (INCLUDING WITHOUT LIMITATION WARRANTIES OF NON-INFRINGEMENT OF INTELLECTUAL PROPERTY RIGHTS OF ANY THIRD PARTY) WITH RESPECT TO ANY AND ALL INFORMATION GIVEN IN THIS APPLICATION NOTE.

Information

For further information on technology, delivery terms and conditions and prices please contact your nearest Infineon Technologies Office (www.infineon.com).

Warnings

Due to technical requirements components may contain dangerous substances. For information on the types in question please contact your nearest Infineon Technologies Office. Infineon Technologies Components may only be used in life-support devices or systems with the express written approval of Infineon Technologies, if a failure of such components can reasonably be expected to cause the failure of that life-support device or system, or to affect the safety or effectiveness of that device or system. Life support devices or systems are intended to be implanted in the human body, or to support and/or maintain and sustain and/or protect human life. If they fail, it is reasonable to assume that the health of the user or other persons may be endangered.

AN2007-06

Revision History: 2010-06, V1.2

Previous Version: 1.1

major changes since last revision

Extended main features with: "Base plate temperature monitoring by internal NTC resistor"

Author: Piotr Luniewski(IFAG IMM INP M AE), Alain Siani(IFAG IMM INP M AE)

We Listen to Your Comments

Any information within this document that you feel is wrong, unclear or missing at all? Your feedback will help us to continuously improve the quality of this document. Please send your proposal (including a reference to this document) to: [\[mailto:IGBT.Application@infineon.com\]](mailto:IGBT.Application@infineon.com)

Module Adapter Board for PrimePACK™ IGBT Modules

Table of contents

1	INTRODUCTION	4
2	DESIGN FEATURES	5
2.1	Main features	5
2.2	Key data	6
2.3	Mechanical dimensions and mounting procedure	6
2.4	Pin assignment.....	7
3	APPLICATION NOTE	9
3.1	Functionality on board	9
3.2	Gate resistors	9
3.3	Gate signal amplifier.....	10
3.4	V _{CE} monitoring for short circuit detection.....	11
3.5	Active voltage clamping – boosted version	11
3.6	Maximum switching frequency.....	12
3.7	Base plate temperature monitoring by internal NTC resistor	14
3.8	Parallel operation	15
4	SCHEMATIC AND LAYOUT OF MA300EXX	15
4.1	Schematic	16
4.2	Assembly drawing	18
4.3	Layout.....	19
4.4	Bill of Material - MA300E12	20
4.5	Bill of Material - MA300E17	21
5	HOW TO ORDER EVALUATION DRIVER BOARDS	22

Part number explanation:

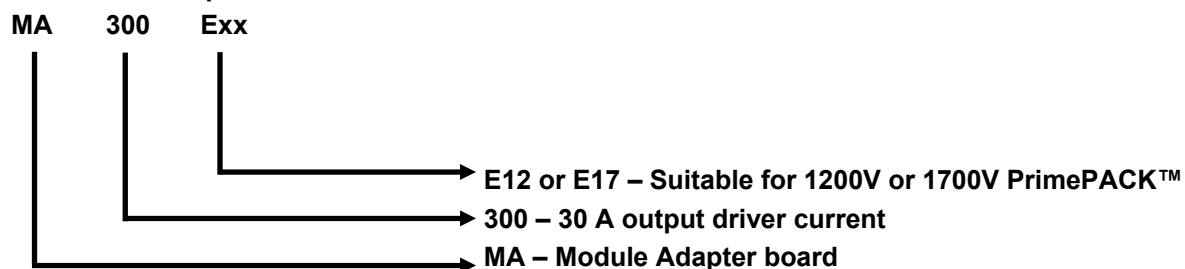

Module Adapter Board for PrimePACK™ IGBT Modules

1 Introduction

The MA300E12 and MA300E17 are developed for 1200V and 1700V PrimePACK™ modules. Used together with the 2ED300E17-SFO evaluation adapter board and 2ED300C17-S /-ST EiceDRIVER™ makes the 'Flexible driver Starter Kit' easy to use (Fig. 2). The 'Flexible Starter Kit' is dedicated for single module operation and simple PrimePACK™ paralleling. In all cases one 2ED300E17-SFO adapter board and one 2ED300C17-S driver is required. Up to three modules can be paralleled, each equipped with one MA300Exx board.

The MA300Exx module adapter boards are available from Infineon in small quantities. Functions and properties of these parts are described in the datasheet chapter of this document whereas the remaining paragraphs provide information intended to enable the customer to copy, modify and qualify the design for their own specific application.

Environmental conditions were considered in the design of the MA300Exx. The requirements for lead-free reflow soldering have been considered when components were selected. However the design was only tested as described in this document but not qualified regarding manufacturing and operation over the whole operating ambient temperature range or lifetime.

The boards provided by Infineon are subjected to functional testing only.

Due to their purpose evaluation boards are not subjected to the same procedures regarding Returned Material Analysis (RMA), Process Change Notification (PCN) and Product Withdraw (PWD) as regular products.

See Legal Disclaimer and Warnings for further restrictions on Infineon warranty and liability.

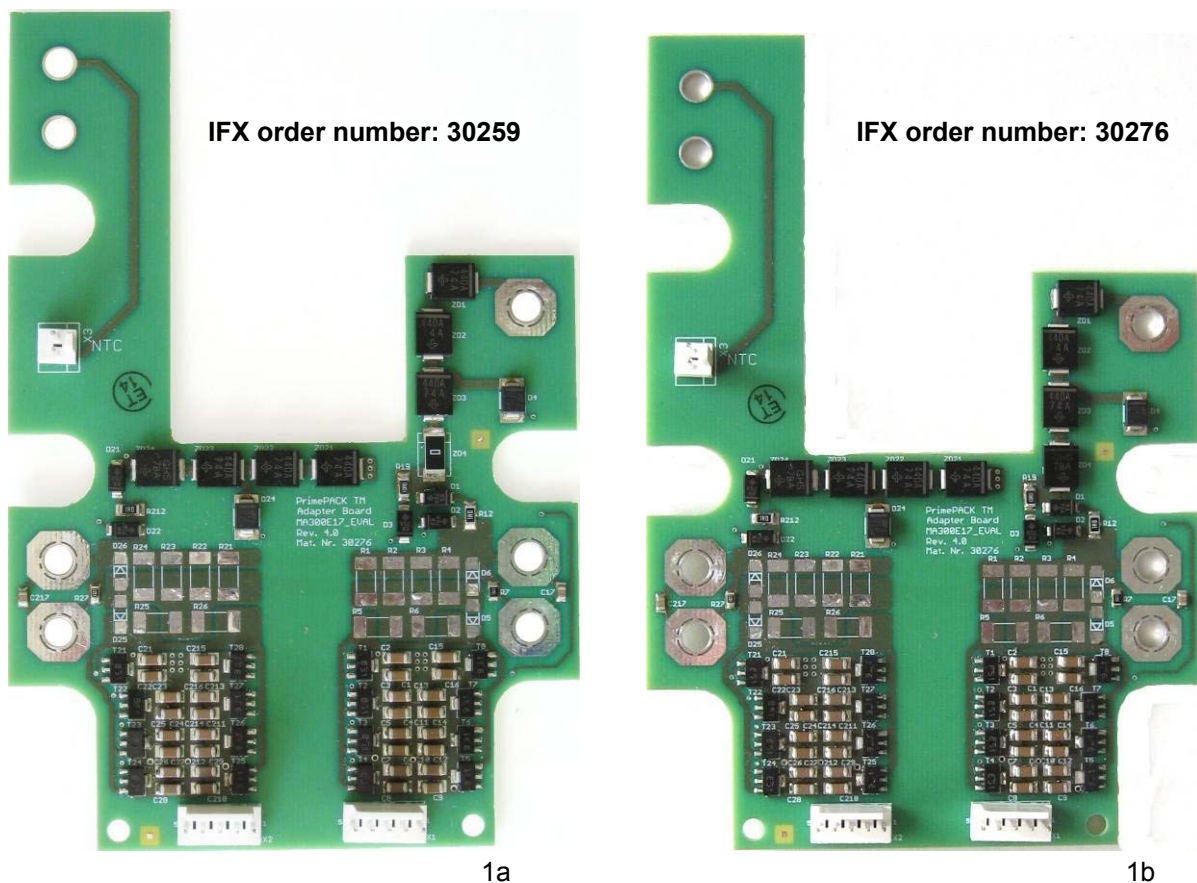

Figure 1 The PrimePACK™ Module Adapter boards, MA300E12 - 1a, MA300E17 – 1b

Module Adapter Board for PrimePACK™ IGBT Modules

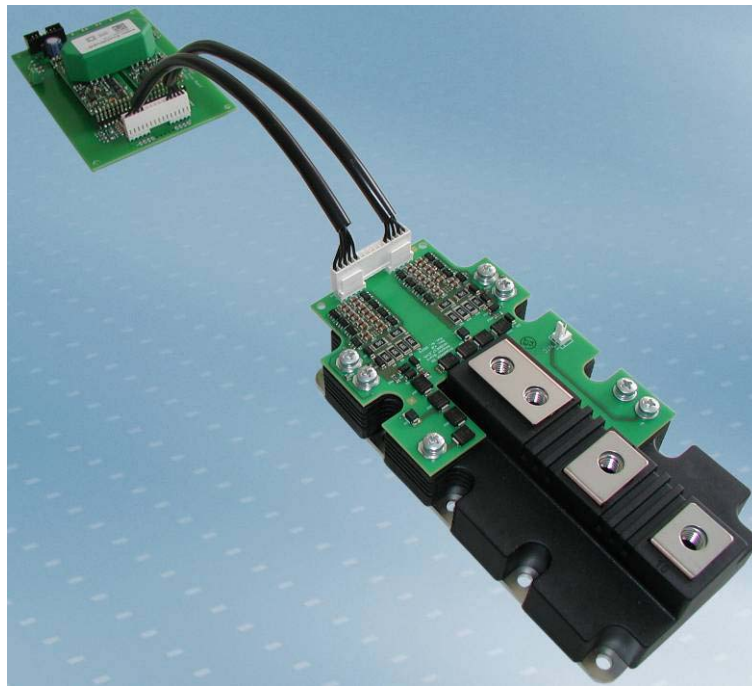

Figure 2 The 'Flexible driver Starter Kit' for PrimePACK™ module

2 Design features

Electrical features of the evaluation board and mechanical dimensions including necessary interface connections are presented in the following sections.

2.1 Main features

The MA300Exx module adapter board offers the following features:

- Dual channel IGBT driver together with 2ED300E17-SFO (detailed description in AN2007-05) and 2ED300C17-S /-ST EiceDRIVER™
- Electrically and mechanically suitable for PrimePACK™ modules family
- Operating temperature (design target) from -55°C to 85°C
- Different gate resistor values for turning-on and -off are possible
- IGBTs are protected against temporary V_{CE} overvoltages during turn-off (Active Clamping)
- Diodes for IGBT desaturation monitoring implemented (short circuit protection)
- Base plate temperature monitoring by internal NTC resistor
- All components, except connectors, are surface mount devices (SMD) with lead free 260°C soldering profile
- PCB is designed to fulfill the requirements of IEC61800-5-1, pollution degree 2, overvoltage category III (creepage – 11mm)

When the MA300Exx is not used with 2ED300E17-SFO adapter board and 2ED300C17-S /-ST EiceDRIVER™ these additional features might be useful:

- Gate-emitter amplifier input resistance is 37Ω
- Can be used with max. ±20V isolated power supply (due to IGBT short circuit performance a max. V_{GE} of +15V is suggested)
- Asymmetric power supply is also allowed e.g. -8V and +15V
- Input PWM voltage level should be selected according to the power supply voltage level. If an asymmetrical supply voltage of -8V/+15V is applied, the PWM signal should not be higher than +15V and should not be lower than -8V

Module Adapter Board for PrimePACK™ IGBT Modules

2.2 Key data

All values given in the table below are typical values, measured at $T_A = 25\text{ °C}$.

Table 1 General key data and characteristic values

Parameter	Description	Value	Unit
V_{DC}	max. DC voltage supply	±20	V
I_G	max. peak output current	±30	A
R_{Gmin}	minimum gate resistor value when $V_{DC}=\pm 15V$ (internal module resistor R_{INT} + external R_{EXT})	1	Ω
$P_{DC/DC}$	max DC/DC output power per one channel ¹	4	W
f_S	max. PWM signal frequency for channel A and B ²	60	kHz
T_{op}	operating temperature (design target) ³	-55...+85	°C
T_{sto}	storage temperature (design target)	-55...+85	°C
I_{NTC}	max. NTC current according to AN2009-10 ⁴	3.74	mA

2.3 Mechanical dimensions and mounting procedure

The MA300Exx should be screwed to the PrimePACK™ auxiliary terminals according to AN2006-09⁵. In that way necessary connections between module adapter and module itself are done correctly (Figure 3). PCB outline and relevant dimensions needed for better system integration are shown in Figure 4.

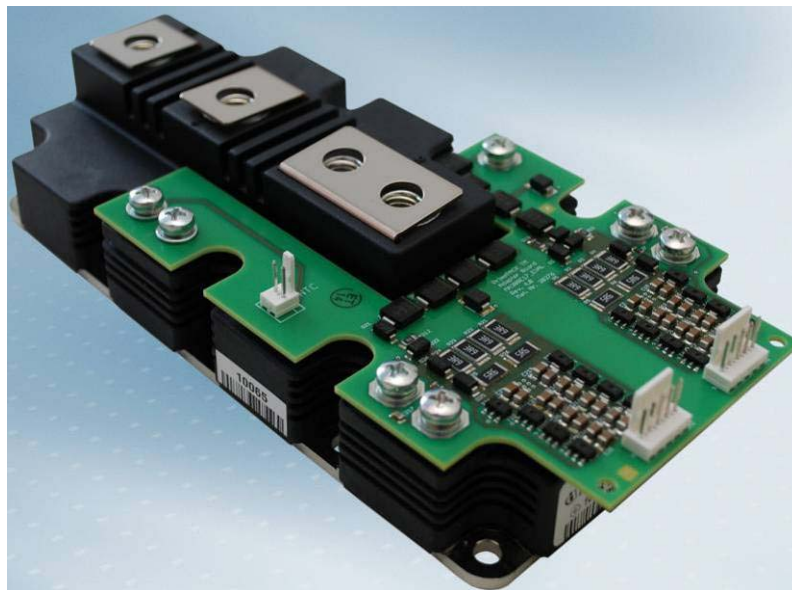

Figure 3 The MA300Exx correctly mounted on PrimePACK™ module

¹ Only when MA300Exx is used together with 2ED300E17-SFO adapter board and 2ED300C17-S EiceDRIVER™

² Switching frequency is limited by 2ED300C17-S EiceDRIVER™ capabilities. The maximum switching frequency for every PrimePACK™ module type should be calculated separately. Limitation factors are: max. DC/DC output power of 4 W per channel and max. PCB board temperature measured around gate resistors placed on separated board closed to IGBT module. For detailed information see chapter 3.6.

³ Max. ambient temperature strictly depends on MA300Exx load conditions.

⁴ The AN2009-10: 'Using the NTC inside a power electronic module', is available on Infineon website.

⁵ The AN2006-09: 'Mounting process PrimePACK modules', is available on Infineon website.

Module Adapter Board for PrimePACK™ IGBT Modules

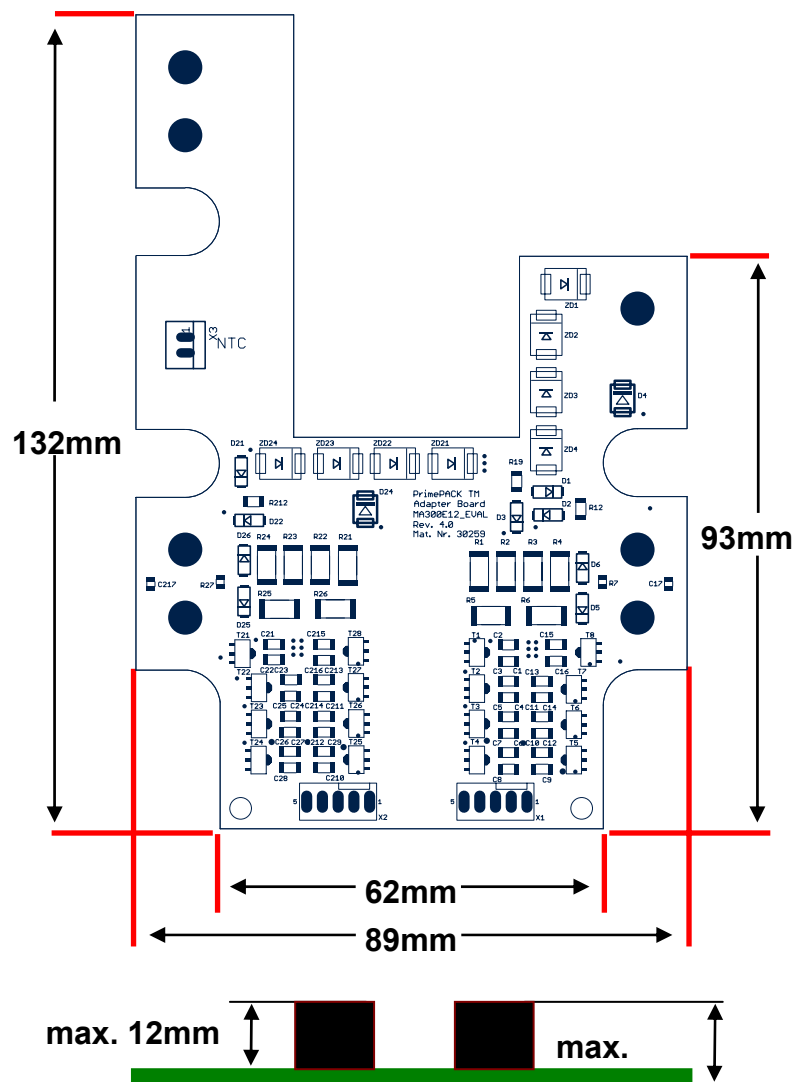

Figure 4 Dimensions of the MA300Exx module adapter board

2.4 Pin assignment

After the module adapter has been correctly mounted to the PrimePACK™ module all external electrical control signals should be applied to connector X1 and X2 as shown on Fig. 6 and listed in Table 2. When MA300Exx is used together with 2ED300E17-SFO the necessary connections to module adapter are depicted in Figure 5. Control signals required for module driving should be connected to Input Interface of 2ED300E17-SFO as described in AN2007-05. In that way no additional connections between module and IGBT driver are needed. The setup ready to use is shown in Fig. 2.

Module Adapter Board for PrimePACK™ IGBT Modules

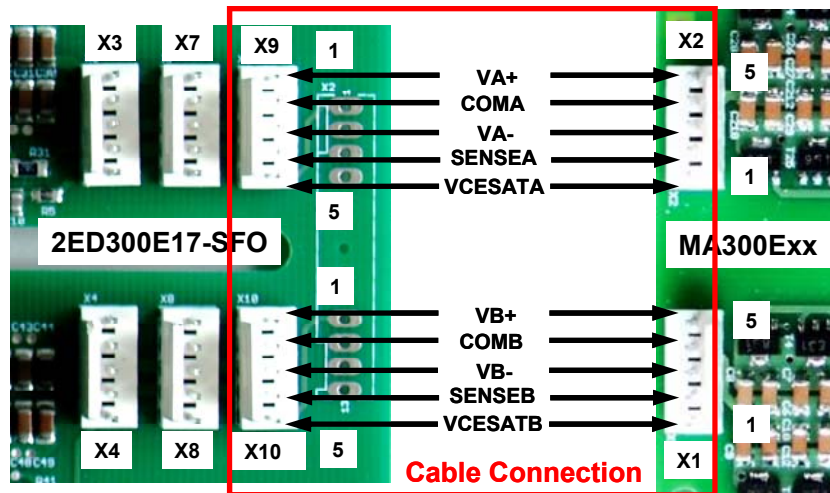

Figure 5 Connections between 2ED300E17-SFO and MA300Exx

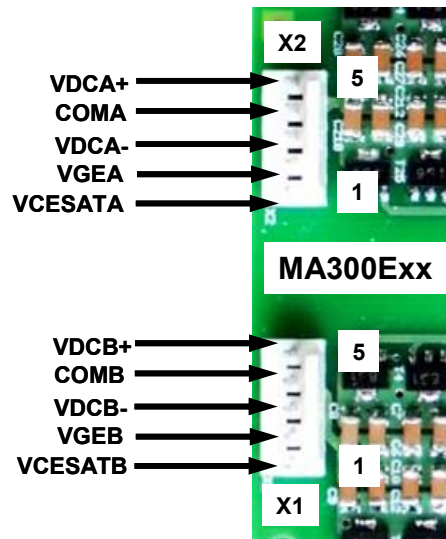

Figure 6 MA300 Module Adapter board and external electrical connections

Table 2 MA300Exx and the external electrical signals description

Pin	Label	Function
X2.5	VDC A+	Isolated DC/DC positive voltage supply channel A
X2.4	COM A	Auxiliary emitter – channel A
X2.3	VDC A-	Isolated DC/DC negative voltage supply channel A
X2.2	VGE A	Gate-emitter signal source – channel A
X2.1	VCESAT A	Desaturation voltage monitoring output – channel A
X1.5	VDC B+	Isolated DC/DC positive voltage supply channel B
X1.4	COM B	Auxiliary emitter – channel B
X1.3	VDC B-	Isolated DC/DC negative voltage supply channel B
X1.2	VGE B	Gate-emitter signal source – channel B
X1.1	VCESAT B	Desaturation voltage monitoring output – channel B

Module Adapter Board for PrimePACK™ IGBT Modules

3 Application Note

3.1 Functionality on board

The MA300Exx basically supports already existing IGBT driver in half-bridge configuration and provides additional functions separately for both channels (top and bottom IGBT):

- Gate resistors
- Gate signal amplifier / emitter follower - booster
- V_{CE} monitoring for short circuit detection
- Active voltage clamping

Picture below depicts the MA300E12 with already mentioned functions and shows their physical location.

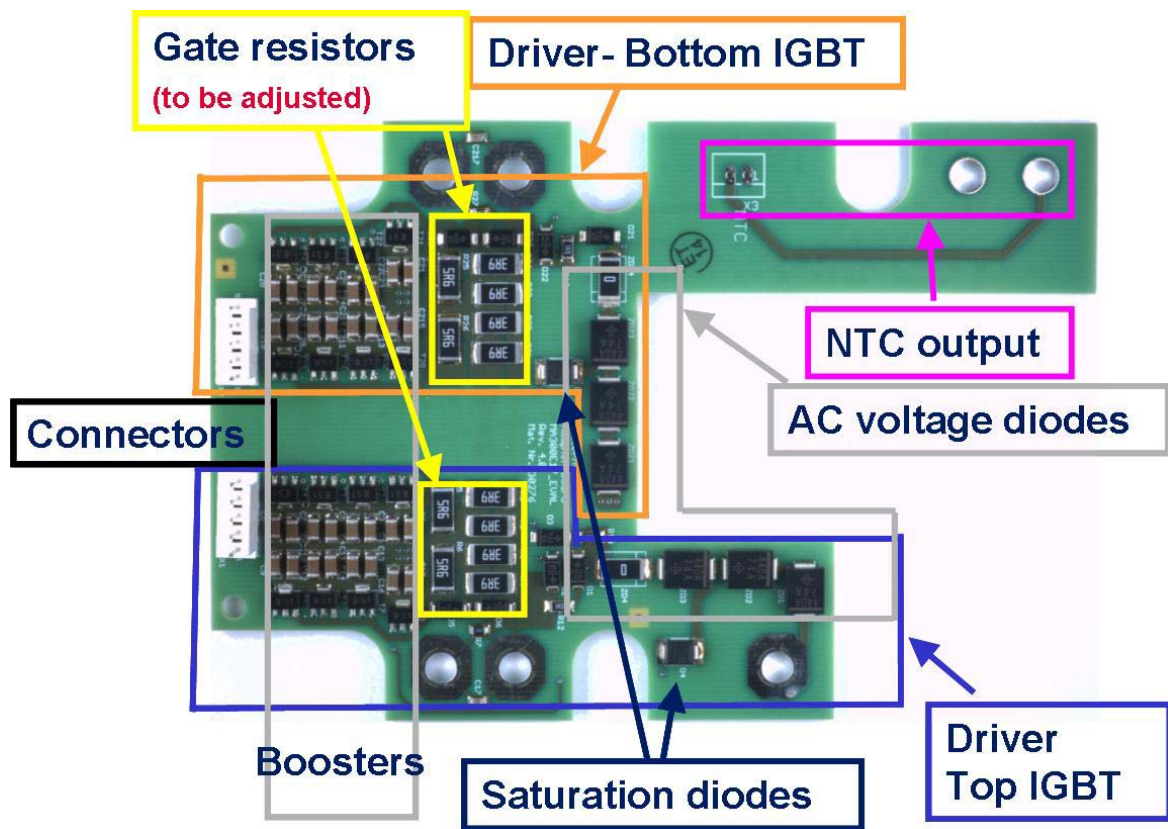

Figure 7 The MA300E12 with marked functions

3.2 Gate resistors

MA300E12 and MA300E17 are assembled and delivered as shown on Fig. 7. The correct gate resistors should be soldered by the customer. Values for 1200V modules are given in Table 3. Table 4 shows values for 1700V IGBTs. All of them are in the 2512 package size (EIA).

Table 3 External gate resistor suggested values for 1200V PrimePACK™ IGBT modules

Module	R5, R6, R25, R26	R1, R2, R3, R4, R21, R22, R23, R24	Resulting R_{Gon}	Resulting R_{Goff}
FF600R12IE4 / IP4	1.5 Ω	5.6 Ω	2.15 Ω	2.15 Ω
FF900R12IP4	0.82 Ω	4.7 Ω	1.58 Ω	1.58 Ω
FF1400R12IP4	0.33 Ω	3.3 Ω	1 Ω	1 Ω

Module Adapter Board for PrimePACK™ IGBT Modules

The values of R_{Gon} and R_{Goff} for 1200V module types are the same and therefore assembly of diodes D5, D25, D6, D26 are not needed.

External gate resistor suggested values for 1700V PrimePACK™ IGBT modules

Module	R5, R6, R25, R26	R1, R2, R3, R4, R21, R22, R23, R24	Resulting R_{Gon}	Resulting R_{Goff}
FF650R17IE4	1.8 Ω	6.8 Ω	1.7 Ω	2.6 Ω
FF1000R17IE4	1.2 Ω	4.7 Ω	1.18 Ω	1.78 Ω
FF1400R17IP4	0.47 Ω	1.8 Ω	0.47 Ω	0.68 Ω

In 1700V PrimePACK™ module types the R_{Goff} is higher than R_{Gon} and therefore diodes D5 and D25 must be fitted as shown on Figure 8.

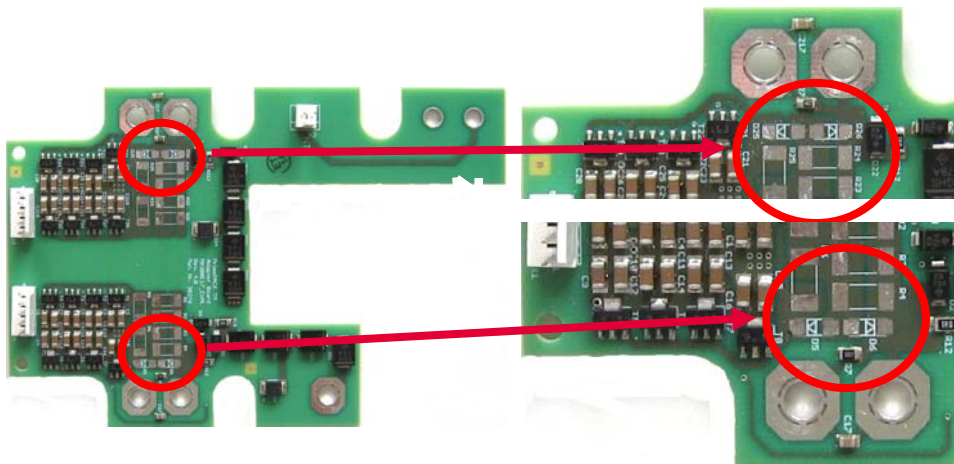

Figure 8 The MA300E17 with mounting direction for D5 and D25

3.3 Gate signal amplifier⁶

When the IGBT transistor switches -on and -off, a high peak of the gate current must be delivered from a driver. Usually there is no technical problem when one module is driven. If one IGBT driver is used for modules connected in parallel the driver's amplifier must deliver the cumulative gate current. This switching condition leads to the gate power loss being concentrated in one relatively small physical area and may result in thermal problems. The high peak currents also require a high current gain driver.

Overcoming gain limitation becomes possible when the module adapter includes a dedicated gate signal amplifier (Fig. 8, Fig. 13 and Fig. 14). MA300Exx have an emitter follower or booster stage already implemented. With four complementary bipolar transistors connected in parallel the minimum gain @ $I_G=30A$ is not smaller than 100⁷.

Due to the fact that every PrimePACK™ has its own module adapter the driving conditions are equal. Input resistance of the module adapter is not smaller than 37 Ω .

Benefits provided by booster:

- Fast control of gate-emitter voltage for every PrimePACK™ module
- Simple module paralleling

⁶ More information EPE07 paper 'Benefits of System-oriented Module Design for High Power Inverters', or PELINCEC2005 paper 'Dynamic Voltage Rise Control – the Most Efficient Way to Control Turn-off Switching Behavior of IGBT Transistors'.

⁷ Based on ZXTN2010Z and ZXTP2012Z bipolar transistors datasheets. www.zetex.com

Module Adapter Board for PrimePACK™ IGBT Modules

3.4 V_{CE} monitoring for short circuit detection

If the IGBT transistor conducts a current a few times higher than the nominal value, the transistor desaturates and the V_{CE} voltage increases. This behavior can be used for short circuit detection and switching-off an IGBT transistor. The short circuit withstand time for Infineon high power IGBT modules is $\leq 10\mu\text{s}$. During this time the short circuit should be detected and the IGBT should be switched off without exceeding V_{CES} .

When MA300Exx is used together with 2ED300E17-SFO the R_{SSD} resistors (Soft Shut Down) must be chosen correctly in order to insure proper short circuit protection. The detailed procedure is described in AN2007-05 chapter 3.5.

Figure 9a shows three FF1000R17IE4 PrimePACK™ modules under short circuit operation where short circuit protection on the 2ED300E17-SFO was disabled. High di_C/dt during switching off creates a large overvoltage spike which is limited by active voltage clamping. Figure 9b depicts how a properly selected R_{SSD} resistor limits the short circuit time ($<10\mu\text{s}$) and slows down the collector current when is turning off.

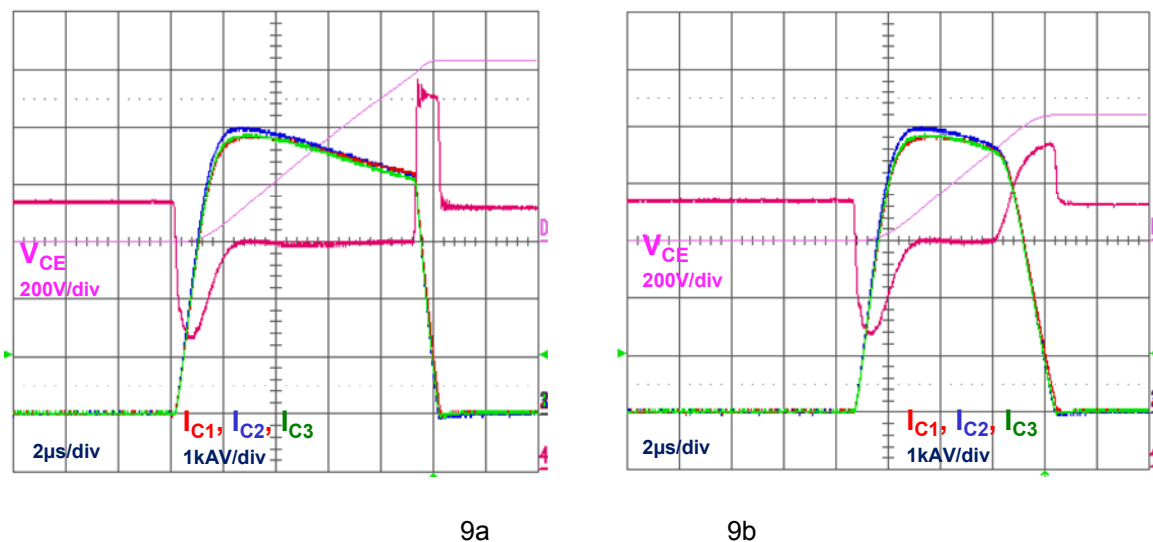

Figure 9 Switching behavior of three paralleled FF1000R17IE4 PrimePACK™ modules under short circuit where system with the 2ED300E17-SFO and MA300E17 applied: short circuit protection disabled 9a and enabled 9b

3.5 Active voltage clamping – boosted version

Active voltage clamping is a technique which keeps transient V_{CE} overvoltages below V_{CES} when the IGBT switches off. The standard approach to active clamping is to use a chain of avalanche diodes connected between the auxiliary collector and the gate of an IGBT module. When the V_{CE} voltage exceeds the diodes breakdown voltage the diodes current sums with the current from the driver output. Due to increased gate-emitter voltage the transistor is held in an active mode and the turn off process is extended. The di_C/dt slows down to a value which results in limited V_{CE} overshoot. Avalanche diodes conduct high peak currents during time period in which V_{CE} overvoltage is limited.

Overvoltage protection of the MA300EXX is based on an improved variant of the active clamping as described above. The clamping diodes are connected directly to the IGBTs gate but also to the input of the amplifier located on the MA300EXX. Therefore the major amount of current for recharging the gate is derived from the gate driver power supply instead of via the clamping diodes. This provides more consistent clamping voltage due to operating the clamping diodes at a lower current level and furthermore enables the clamping circuit to be designed independently from the selected external gate resistor. Finally the same circuit for 1200V and 1700V modules using different diodes types has been realized and is shown in Fig. 1.

Module Adapter Board for PrimePACK™ IGBT Modules

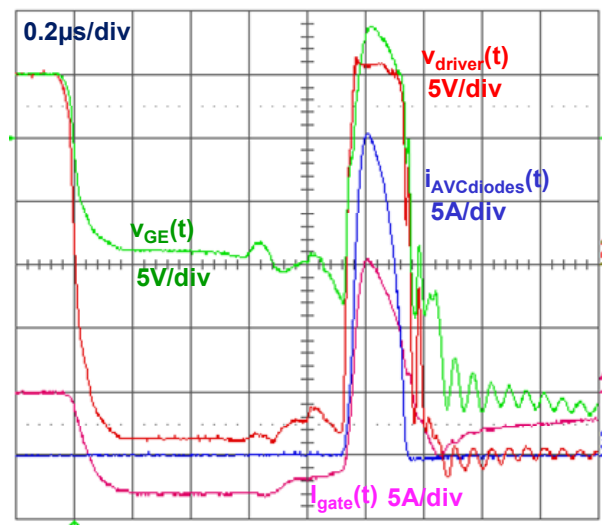

Figure 10 Switching off behavior of the FF1000R17IE4 PrimePACK™ module with boosted active clamping where: $V_{DC}=900V$, $I_C=2500A$, $R_{Goff}=1,5\Omega$ and $T_J=25^\circ C$

3.6 Maximum switching frequency

The switching frequency of an IGBT is limited either by the maximal power of the driver voltage supply or by the maximal temperature of the PCB due to the power losses in the external gate resistors. These power losses in the gate resistors depend on the IGBT gate charge, gate voltage magnitude and on the switching frequency of the IGBT. Due to the power losses in the external gate resistors, the heat will be generated, which leads to increase of the PCB temperature in the neighborhood of these resistors. This temperature must not be higher than the melting temperature of the PCB, i.e. $105^\circ C$ for a standard FR4 material. The calculation of the power losses in the gate resistors can be done by utilizing Equation 1:

$$P_{dis} = P(R_{EXT}) + P(R_{INT}) = \Delta V_{out} \cdot f_s \cdot Q_G \quad (1)$$

where:

P_{dis} = dissipated power,

ΔV_{out} = voltage step at the driver output

f_s = switching frequency,

Q_G = IGBT gate charge (for the given gate voltage range)

The complete gate resistor consists of the internal gate resistor R_{GINT} together with an external gate resistor R_{GEXT} and due to that, a part of the IGBT power losses will be dissipated directly through the DCB into the base plate, whereas the other part of the power losses will be dissipated externally in the ambient air and in the PCB. The ratio of the losses dissipated internally $P(R_{GINT})$ and externally $P(R_{GEXT})$ corresponds directly to the ratio of the mentioned R_{GINT} and R_{GEXT} resistors. Figure 11 presents a measurement result showing the external gate resistor temperature in dependency on the power transformed in that resistor. It can be read from the graph, that for the ambient temperature of $25^\circ C$ and the base plate temperature of $125^\circ C$ the maximal temperature of the PCB reaches $105^\circ C$ with power losses in R_{GEXT} equal to 1.1W. In that case, the limiting factor for the switching frequency is not the DC-DC converter, with its available power of 4W pro channel, but the maximal temperature of the PCB. Higher switching frequency can be only obtained by utilizing a PCB with higher melting temperature.

Module Adapter Board for PrimePACK™ IGBT Modules

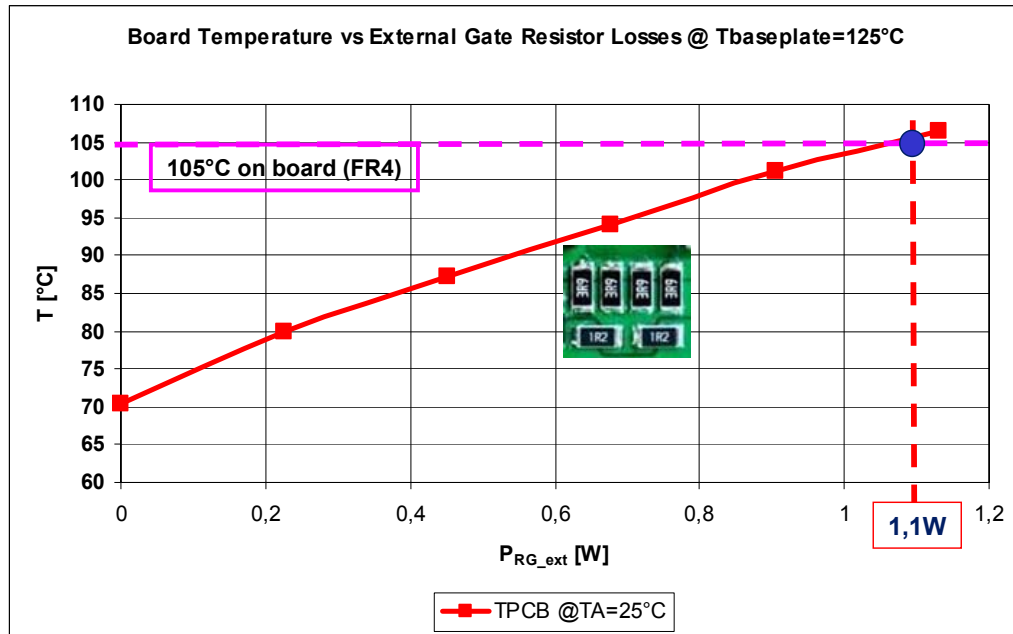

Figure 11 PCB temperature vs. gate resistor power losses

Table 4 Calculated max. IGBT switching frequencies for 2ED300E17-SFO with MA300Exx and single PrimePACK™ module

Module	R_{EXT}/Ω	R_{INT}/Ω	$f_s@T_a=25^\circ\text{C}$ and $T_{baseplate}=125^\circ\text{C}$	f_s Limited by
FF600R12IE4	2.2	1.8	10.8 kHz	R_G power dissipation
FF600R12IP4	2.2	1.8	10.8 kHz	R_G power dissipation
FF900R12IP4	1.6	1.2	7 kHz	R_G power dissipation
FF1400R12IP4	1.0	0.8	4.7 kHz	R_G power dissipation
FF650R17IE4	2.7 ⁸	2.3	8 kHz	R_G power dissipation
FF1000R17IE4	1.8 ⁹	1.5	5.6 kHz	R_G power dissipation
FF1400R17IP4	0.68	1.6	7.5kHz	R_G power dissipation

In order to calculate allowed power losses $P(R_{EXT})$ when base plate and ambient temperatures differ from the example shown above the formula (2) can be used.

$$\frac{P(R_{EXT})}{W} = \frac{(105 - T_{baseplate} / ^\circ\text{C})}{71} + \frac{(105^\circ\text{C} - T_{ambient} / ^\circ\text{C})}{58} \quad (2)$$

Finally, the suggested IGBT maximum switching frequency for given $T_{base\ plate}$ and $T_{ambient}$ for MA300Exx used together with 2ED300E17-SFO is given by formula (3)

$$f_s[\text{Hz}] \frac{f_s}{\text{Hz}} = \frac{\frac{P(R_{EXT})}{W} * \left(\frac{R_{INT}}{\Omega} + \frac{R_{EXT}}{\Omega} \right)}{30 * k * \frac{R_{EXT}}{\Omega} * \frac{Q_g}{\mu\text{C}}} \quad (3)$$

Where the tolerance factor $k=1.2$

⁹ Based on highest external gate resistor value

Module Adapter Board for PrimePACK™ IGBT Modules

The driving power increases accordingly to the number of paralleled modules and their switching frequency. The maximum switching frequency in this case is determined by the PCB temperature and the available driving power (4W when used with 2ED300E17-SFO). Table 5 shows switching frequencies where two modules are connected in parallel and Table 6 when the number is three. Both limitation factors are considered.

Table 5 Calculated max. IGBT switching frequencies for 2ED300E17-SFO with MA300Exx and two PrimePACK™ modules in parallel

Module	R_{EXT}/Ω	R_{INT}/Ω	$f_s@T_a=25^\circ\text{C}$ and $T_{base\ plate}=125^\circ\text{C}$	f_s limited by
FF600R12IE4	2.2	1.8	10.8 kHz	R_G power dissipation
FF600R12IP4	2.2	1.8	10.8 kHz	R_G power dissipation
FF900R12IP4	1.6	1.2	7 kHz	R_G power dissipation
FF1400R12IP4	1.0	0.8	4.7 kHz	R_G power dissipation
FF650R17IE4	2.7	2.3	8 kHz	R_G power dissipation
FF1000R17IE4	1.8	1.5	5.6 kHz	R_G power dissipation
FF1400R17IP4	0.68	1.6	4.1 kHz	DC/DC power capability

Table 6 Calculated max. IGBT switching frequencies for 2ED300E17-SFO with MA300Exx and three PrimePACK™ modules in parallel

Module	R_{EXT}/Ω	R_{INT}/Ω	$f_s@T_a=25^\circ\text{C}$ and $T_{base\ plate}=125^\circ\text{C}$	f_s limited by
FF600R12IE4	2.2	1.8	7.4 kHz	DC/DC power capability
FF600R12IP4	2.2	1.8	7.4 kHz	DC/DC power capability
FF900R12IP4	1.6	1.2	4.8 kHz	DC/DC power capability
FF1400R12IP4	1.0	0.8	3.2 kHz	DC/DC power capability
FF650R17IE4	2.7	2.3	5.2 kHz	DC/DC power capability
FF1000R17IE4	1.8	1.5	3.7 kHz	DC/DC power capability
FF1400R17IP4	0.68	1.6	2.7 kHz	DC/DC power capability

3.7 Base plate temperature monitoring by internal NTC resistor

The IGBT module base plate temperature can be monitored by proper usage of the NTC resistor built into the module. Electronic acquisition of the NTC temperature requires an external circuit and some examples of circuits and details of the NTC characteristics are described in the application note: [AN2009-10](#).

Notice: This temperature measurement is not suitable for short circuit detection or short term overload and may be used to protect the module from long term overload conditions or malfunction of the cooling system.

An electrical isolation must be assured between the NTC input signal (IGBT side) and the NTC output control signal.

Module Adapter Board for PrimePACK™ IGBT Modules

3.8 Parallel operation

The Flexible Starter Kit⁹ can be used for driving one PrimePACK™ module as shown on Fig. 2 or up to three paralleled PrimePACK™ modules. In this case all the PrimePACK™ modules should have dedicated MA300Exx boards connected to the 2ED300E17-SFO adapter board as shown on Figure 12. It must be noted that R_{SSD} resistor in every case should be selected accordingly to [AN2007-05](#) chapter 3.5.

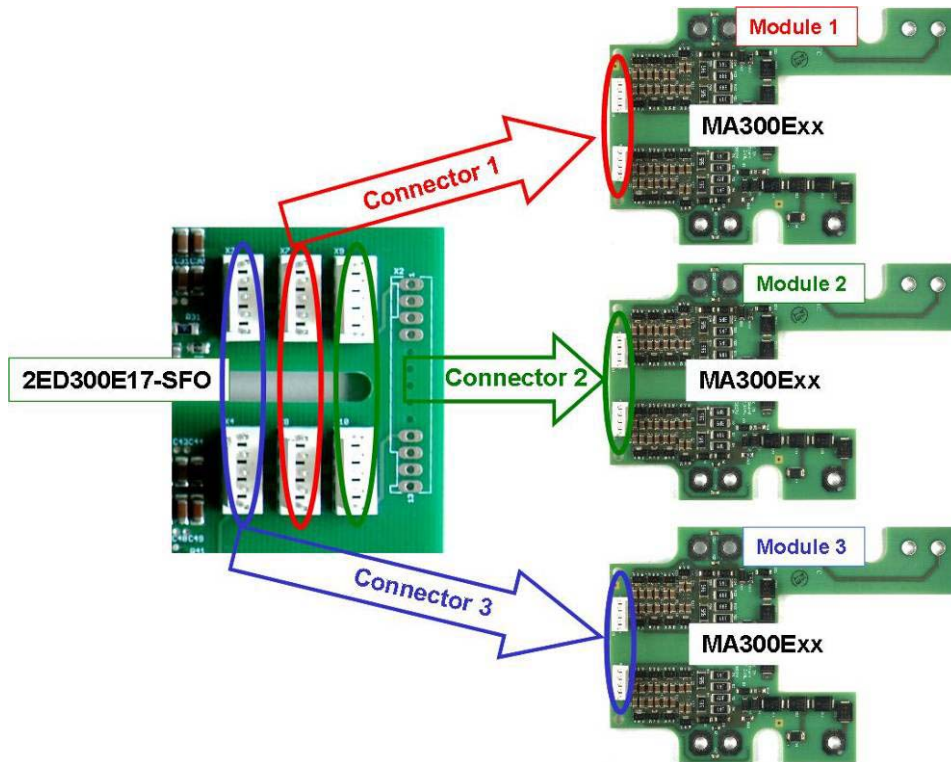

Figure 12 Connections between MA300Exx and 2ED300E17-SFO with three PrimePACK™ modules in parallel

4 Schematic and Layout of MA300Exx

To meet the individual customer requirements and to make the evaluation board simple for further development or modification, all necessary technical data including schematics, PCB layout and components are included in this chapter.

⁹consisting of one 2ED300E17-SFO, one 2ED300E17-S /-ST driver board and MA300Exx module adapter board

Module Adapter Board for PrimePACK™ IGBT Modules

4.1 Schematic

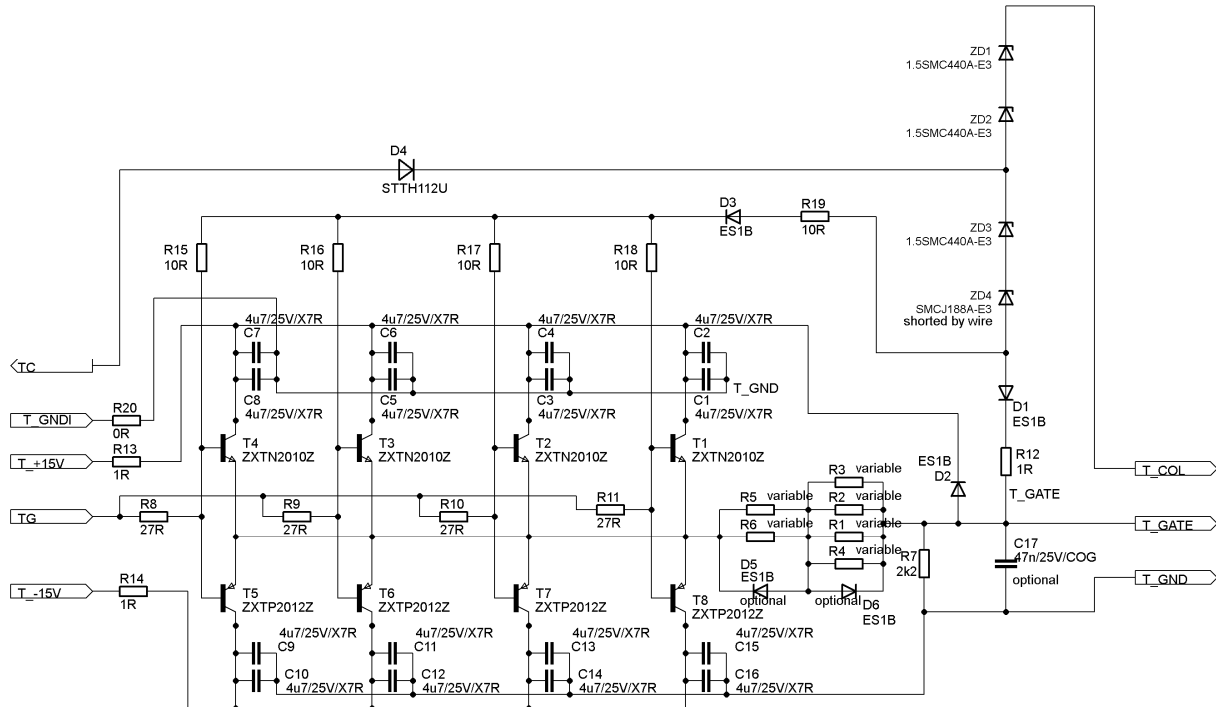

Figure 13 The MA300Exx – top IGBT

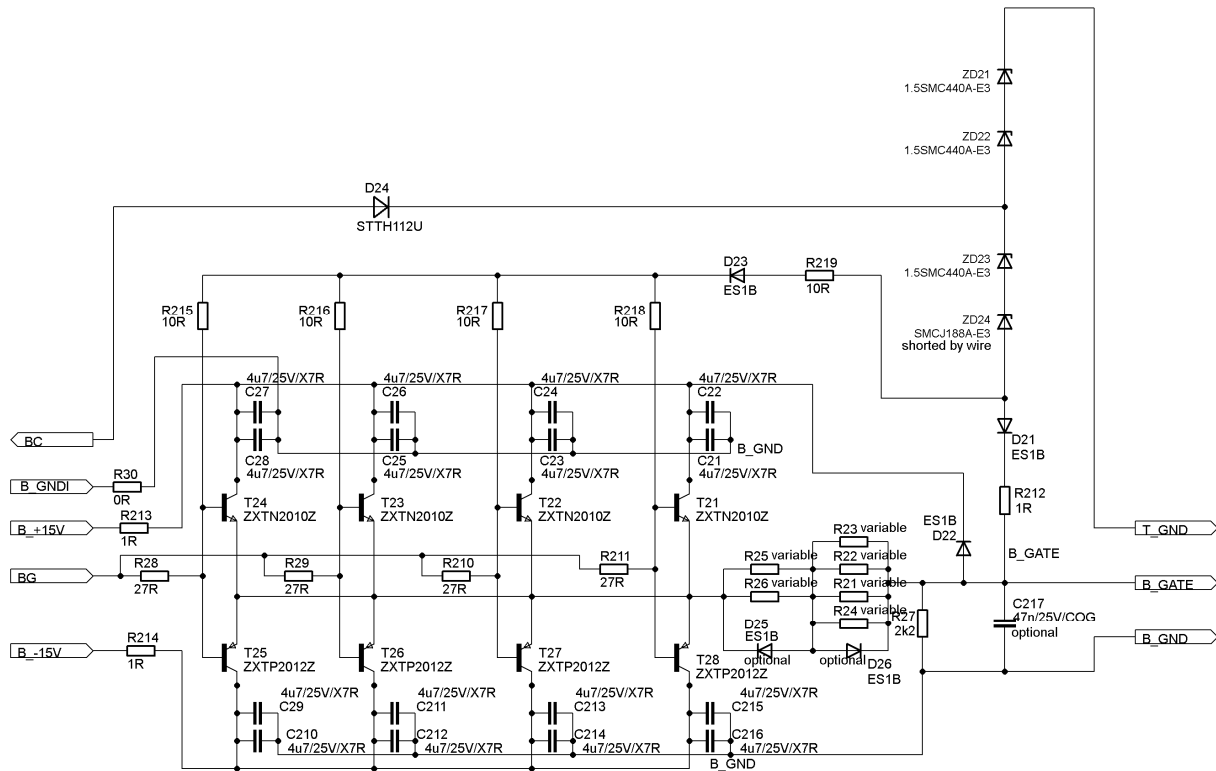

Figure 14 The MA300Exx – bottom IGBT

Module Adapter Board for PrimePACK™ IGBT Modules

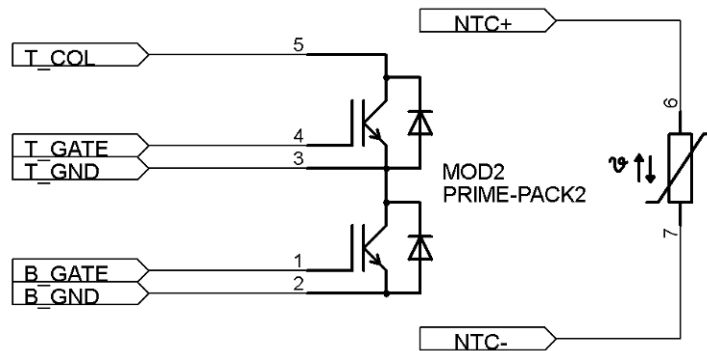

Figure 15 The MA300Exx – main connectors

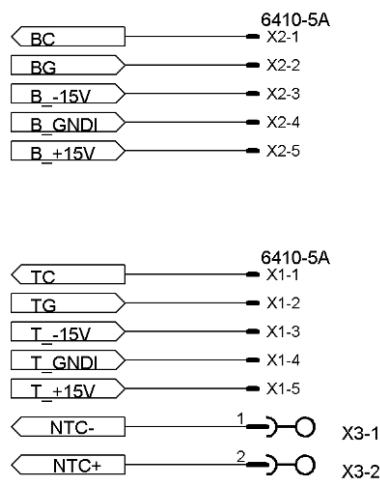

Figure 16 The MA300Exx – external connectors

Module Adapter Board for PrimePACK™ IGBT Modules

4.2 Assembly drawing

Basic circuit and layout for the MA300E12 and MA300E17 are similar. The only differences are the transil diodes: ZD1, ZD2, ZD3, ZD4, ZD21, ZD22, ZD23, ZD24 types and assembly. Gate resistors should be assembled accordingly to Table 3 and active clamping diodes should be assembled accordingly to Table 7.

Table 7 Assembly Active clamping diodes on the MA300Exx board

Board Names	Assembled diodes	Types of assembled diodes
MA300E12_EVAL	ZD1, ZD2, ZD3, ZD4 ZD21, ZD22, ZD23, ZD24	SMJC188A
MA300E17_EVAL	ZD1, ZD2, ZD3, ZD21, ZD22, ZD23	1.5SMC440A
	ZD4, ZD24	Shorted by wire or 0R resistor

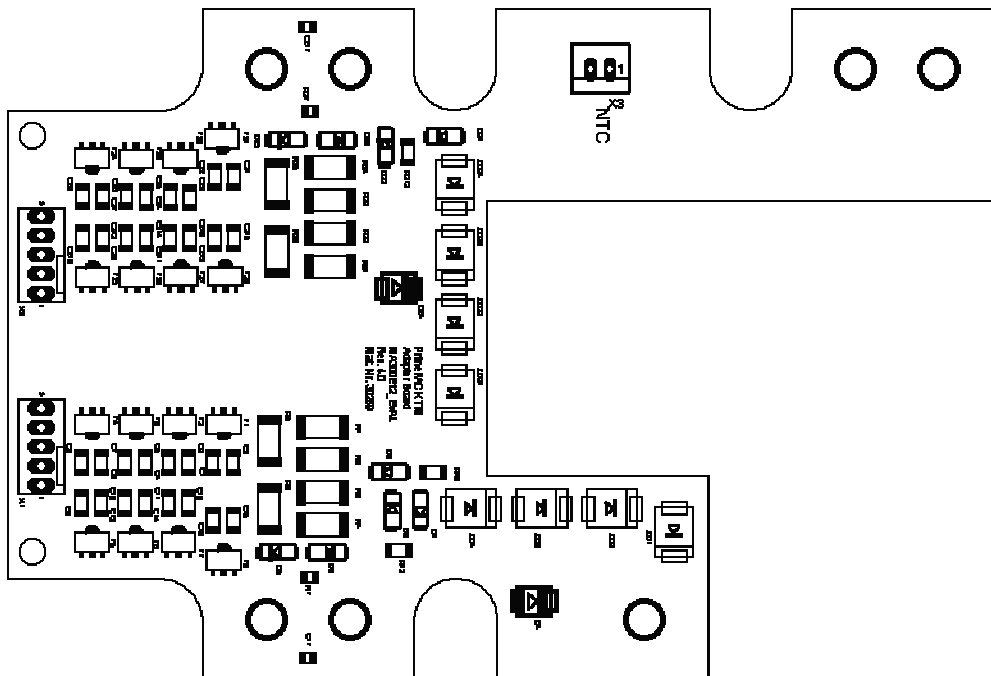

Figure 17 The MA300Exx – assembly drawing

Module Adapter Board for PrimePACK™ IGBT Modules

4.3 Layout

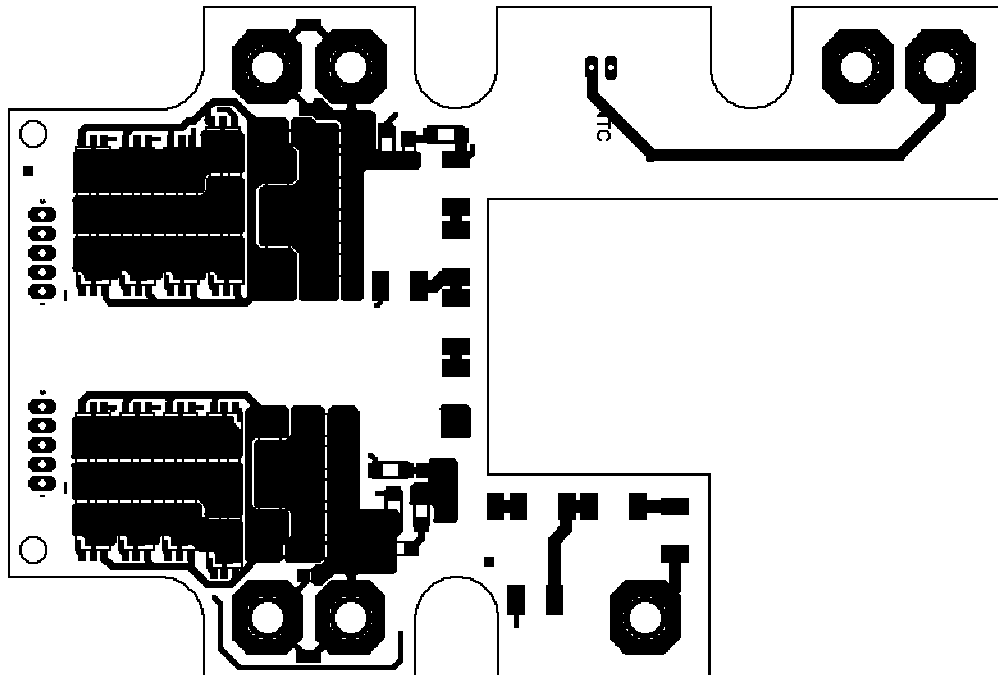

Figure 18 The MA300Exx – Top layer

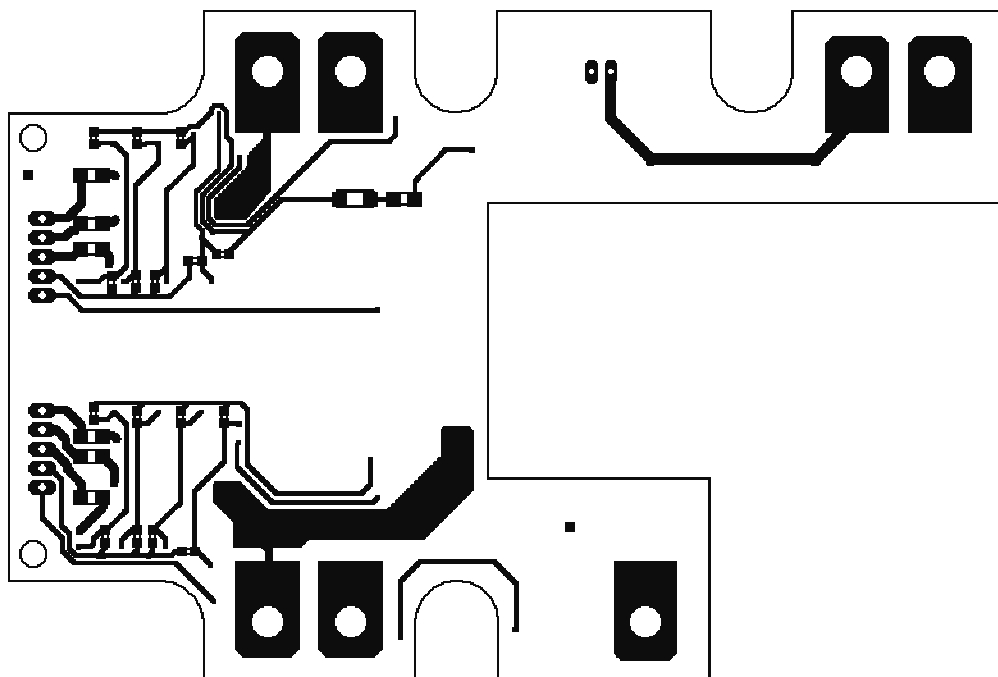

Figure 19 The MA300Exx – Bottom layer

Module Adapter Board for PrimePACK™ IGBT Modules

4.4 Bill of Material - MA300E12

The bill of material includes a part list as well as assembly notes.

The tolerances for resistors should be less or equal to $\pm 1\%$, for capacitors of the type C0G less or equal to $\pm 5\%$ and for capacitors of the type X7R less or equal to $\pm 10\%$.

Table 8 Bill of Material for MA300E12 adapter board

Type	Value / Type	Package size imperial	QTY	Name Part	Recommended Manufacturer	Assembly
Resistor	see chapter 3.2*	2512	12	R1, R2, R3, R4, R5, R6, R21, R22, R23, R24, R25, R26	special pulse resistors	no
Resistor	1R	1206	6	R12, R13, R14, R20, R30, R212, R213, R214	special pulse resistors	yes
Resistor	10R	1206	2	R19, R219	no special	yes
Resistor	10R	0603	8	R15, R16, R17, R18, R215, R216, R217, R218,	no special	yes
Resistor	27R	0603	8	R8, R9, R10, R11, R28, R29, R210, R211,	no special	yes
Resistor	2k2	0805	2	R7, R27	no special	yes
Capacitor	variable	0805	2	C17, C217	no special	no
Capacitor	4 μ 7/25V/X7R	1206	32	C1, C2, C3, C4, C5, C6, C7, C8, C9, C10, C11, C12, C13, C14, C15, C16, C21, C22, C23, C24, C25, C26, C27, C28, C29, C210, C211, C212, C213, C214, C215, C216,	Murata	yes
Semiconductor	ZXTN2010Z	SOT89	8	T1, T2, T3, T4, T21, T22, T23, T24,	Zetex	yes
Semiconductor	ZXTP2012Z	SOT89	8	T5, T6, T7, T8, T25, T26, T27, T28	Zetex	yes
Semiconductor	ES1B (see chapter 3.2)	DO214AC	4	D5, D6, D25, D26	Vishay	no
Semiconductor	ES1B	DO214AC	6	D1, D2, D3, D21, D22, D23	Vishay	yes
Semiconductor	STTH112U	SMB	2	D4, D24	STM	yes
Semiconductor	SMCJ188A	SMC	8	ZD1, ZD2, ZD3, ZD4, ZD21, ZD22, ZD23, ZD24	Vishay	yes
Connector	6410-5A		2	X1, X2	Molex (22-27-2051)	yes
Connector	6373-4A		1	X3	Molex (22112022)	yes

*Pulse power rated types

Module Adapter Board for PrimePACK™ IGBT Modules

4.5 Bill of Material - MA300E17

The bill of material includes a part list as well as assembly notes.

The tolerances for resistors should be less or equal to $\pm 1\%$, for capacitors of the type C0G less or equal to $\pm 5\%$ and for capacitors of the type X7R less or equal to $\pm 10\%$.

Table 9 Bill of Material for MA300E17 adapter board

Type	Value / Type	Package size imperial	QTY	Name Part	Recommended Manufacturer	Assembly
Resistor	see chapter 3.2*	2512	12	R1, R2, R3, R4, R5, R6, R21, R22, R23, R24, R25, R26	special pulse resistors	no
Resistor	1R	1206	6	R12, R13, R14, R20, R30, R212, R213, R214	special pulse resistors	yes
Resistor	10R	1206	2	R19, R219	no special	yes
Resistor	10R	0603	8	R15, R16, R17, R18, R215, R216, R217, R218,	no special	yes
Resistor	27R	0603	8	R8, R9, R10, R11, R28, R29, R210, R211,	no special	yes
Resistor	2k2	0805	2	R7, R27	no special	yes
Capacitor	variable	0805	2	C17, C217	no special	no
Capacitor	4 μ 7/25V/X7R	1206	32	C1, C2, C3, C4, C5, C6, C7, C8, C9, C10, C11, C12, C13, C14, C15, C16, C21, C22, C23, C24, C25, C26, C27, C28, C29, C210, C211, C212, C213, C214, C215, C216,	Murata	yes
Semiconductor	ZXTN2010Z	SOT89	8	T1, T2, T3, T4, T21, T22, T23, T24,	Zetex	yes
Semiconductor	ZXTP2012Z	SOT89	8	T5, T6, T7, T8, T25, T26, T27, T28	Zetex	yes
Semiconductor	ES1B (see chapter 3.2)	DO214AC	4	D5, D6, D25, D26	Vishay	no
Semiconductor	ES1B	DO214AC	6	D1, D2, D3, D21, D22, D23	Vishay	yes
Semiconductor	STTH112U	SMB	2	D4, D24	STM	yes
Semiconductor	1.5SMC440A	SMC	6	ZD1, ZD2, ZD3, ZD21, ZD22, ZD23,	Vishay	yes
Semiconductor	0R		2	ZD4, ZD24	Vishay	yes
Connector	6410-5A		2	X1, X2	Molex (22-27-2051)	Yes
Connector	6373-4A		1	X3	Molex (22112022)	yes

*Pulse power rated types

Module Adapter Board for PrimePACK™ IGBT Modules

5 How to order Evaluation Driver Boards

Every Evaluation Driver Board has its own IFX order number and can be ordered via your Infineon Sales Partner.

Information can also be found at the Infineons Web Page: www.infineon.com

CAD-data for the board described here are available on request. The use of this data is subjected to the disclaimer given in this AN. Please contact: WAR-IGBT.Application@infineon.com

IFX order number for MA300E12: 30259

IFX order number for MA300E17: 30276

IFX order number for 2ED300E17-SFO: 30272

IFX order number for 2ED300C17-S: 29831

IFX order number for 2ED300C17-ST: 29832