

TLD5501-2ADBPREF board

User guide

Z8F80390721

About this document

The TLD5501-2QV used in this reference board, is an AEC qualified dual sync buck controller with SPI interface, especially designed to be used as voltage or current regulator in, for example, an LED driver. The main features are:

- Wide V_{IN} range (IC 4.5 V to 40 V, Power 4.5 V to 55 V)
- SPI for diagnostics and control
- Maximum efficiency under every condition, up to 96%
- Constant current for LED applications and constant voltage regulation
- Limp home function in fail-safe mode
- EMC optimized device: Features an auto spread spectrum
- Overvoltage, short to ground, overcurrent, open feedback and overtemperature diagnostic output

Scope and purpose

The scope of this user guide is to provide instructions on the use of TLD5501-2QV dual channel voltage pre-regulator for adaptive drive beam (ADB) reference board, TLD5501-2ADBPREF.

Intended audience

This document is intended for engineers who need to perform measurements and check performance with TLD5501-2QV dual channel voltage pre-regulator for adaptive drive beam (ADB) reference board, TLD5501-2ADBPREF.

Important notice

“Evaluation Boards and Reference Boards” shall mean products embedded on a printed circuit board (PCB) for demonstration and/or evaluation purposes, which include, without limitation, demonstration, reference and evaluation boards, kits and design (collectively referred to as “Reference Board”).

Environmental conditions have been considered in the design of the Evaluation Boards and Reference Boards provided by Infineon Technologies. The design of the Evaluation Boards and Reference Boards has been tested by Infineon Technologies only as described in this document. The design is not qualified in terms of safety requirements, manufacturing and operation over the entire operating temperature range or lifetime.

The Evaluation Boards and Reference Boards provided by Infineon Technologies are subject to functional testing only under typical load conditions. Evaluation Boards and Reference Boards are not subject to the same procedures as regular products regarding returned material analysis (RMA), process change notification (PCN) and product discontinuation (PD).

Evaluation Boards and Reference Boards are not commercialized products, and are solely intended for evaluation and testing purposes. In particular, they shall not be used for reliability testing or production. The Evaluation Boards and Reference Boards may therefore not comply with CE or similar standards (including but not limited to the EMC Directive 2004/EC/108 and the EMC Act) and may not fulfill other requirements of the country in which they are operated by the customer. The customer shall ensure that all Evaluation Boards and Reference Boards will be handled in a way which is compliant with the relevant requirements and standards of the country in which they are operated.

The Evaluation Boards and Reference Boards as well as the information provided in this document are addressed only to qualified and skilled technical staff, for laboratory usage, and shall be used and managed according to the terms and conditions set forth in this document and in other related documentation supplied with the respective Evaluation Board or Reference Board.

It is the responsibility of the customer’s technical departments to evaluate the suitability of the Evaluation Boards and Reference Boards for the intended application, and to evaluate the completeness and correctness of the information provided in this document with respect to such application.

The customer is obliged to ensure that the use of the Evaluation Boards and Reference Boards does not cause any harm to persons or third party property.

The Evaluation Boards and Reference Boards and any information in this document is provided "as is" and Infineon Technologies disclaims any warranties, express or implied, including but not limited to warranties of non-infringement of third party rights and implied warranties of fitness for any purpose, or for merchantability.

Infineon Technologies shall not be responsible for any damages resulting from the use of the Evaluation Boards and Reference Boards and/or from any information provided in this document. The customer is obliged to defend, indemnify and hold Infineon Technologies harmless from and against any claims or damages arising out of or resulting from any use thereof.

Infineon Technologies reserves the right to modify this document and/or any information provided herein at any time without further notice.

Table of contents

	About this document	1
	Important notice	2
	Table of contents	3
1	Description	4
2	Quick start procedure	6
3	Board control with PC GUI	8
4	Infineon μIO-Stick and Developer Center Launcher	9
5	Installing the graphical user interface (GUI)	10
6	TLD5501-2QV GUI	12
7	Schematics	13
8	PCB layout	16
9	Bill of material	18
10	Electrical performance	20
11	Efficiency measurement	23
	References	24
	Revision history	25
	Disclaimer	26

1 Description

1 Description

The TLD5501-2ADBPREF dual channel voltage pre-regulator reference board is composed of two independent synchronous buck converters configured as constant voltage power supply. It can be set for a constant voltage output up to 5.0 V and a current up to 12 A per channel.

This board can be also controlled by an Infineon μ IO-stick and a specific GUI for PC. The Infineon μ IO-stick is a device that enables the communication between the board and the PC GUI by means of SPI using the Config Wizard software, which can be downloaded via the Infineon Developer Center [2] (see Chapter 4 for detailed instructions).

This board can also be configured to run in standalone mode, without any device that controls it, as described in Chapter 2.

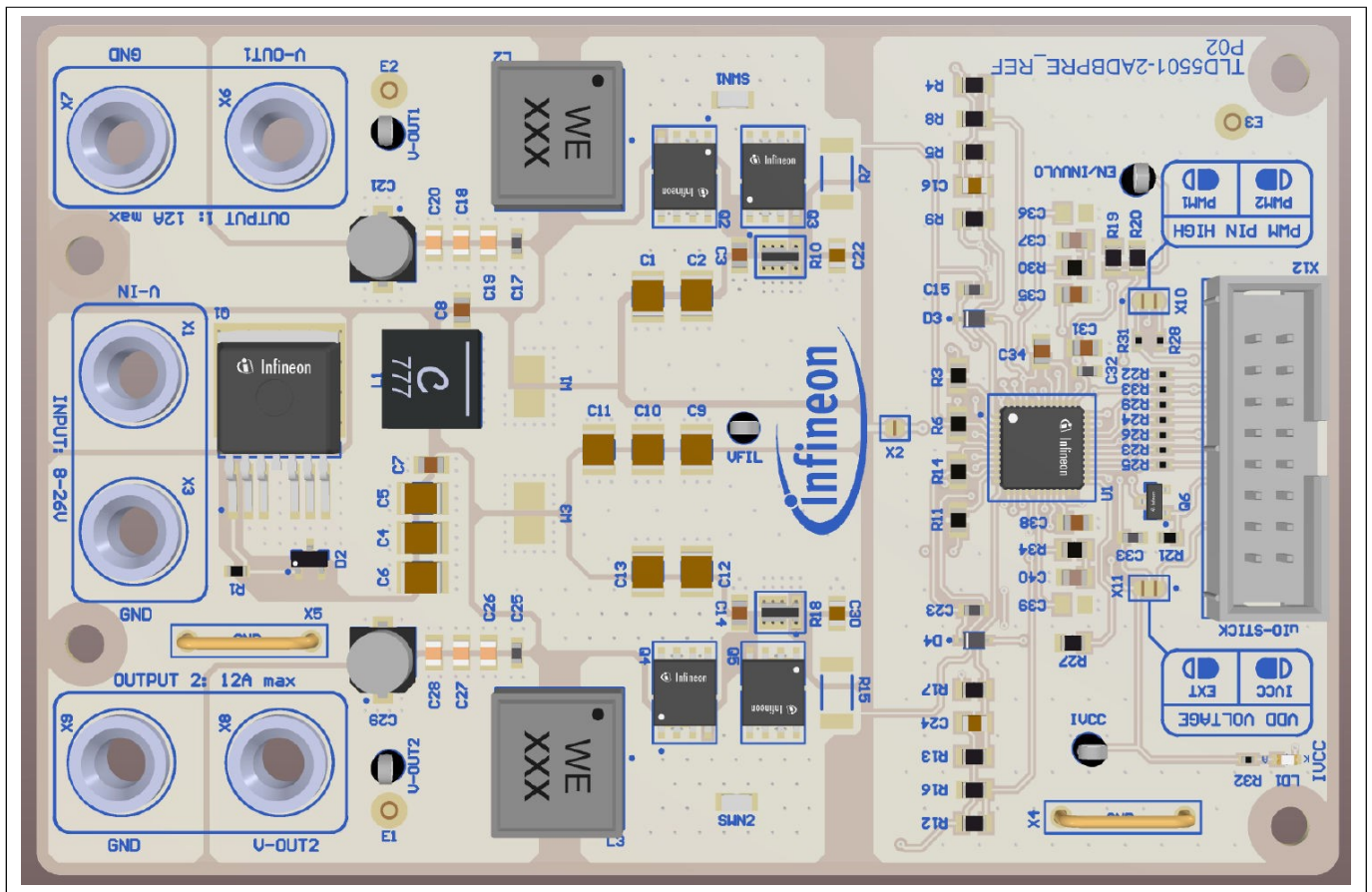

Figure 1 Board illustration

1 Description

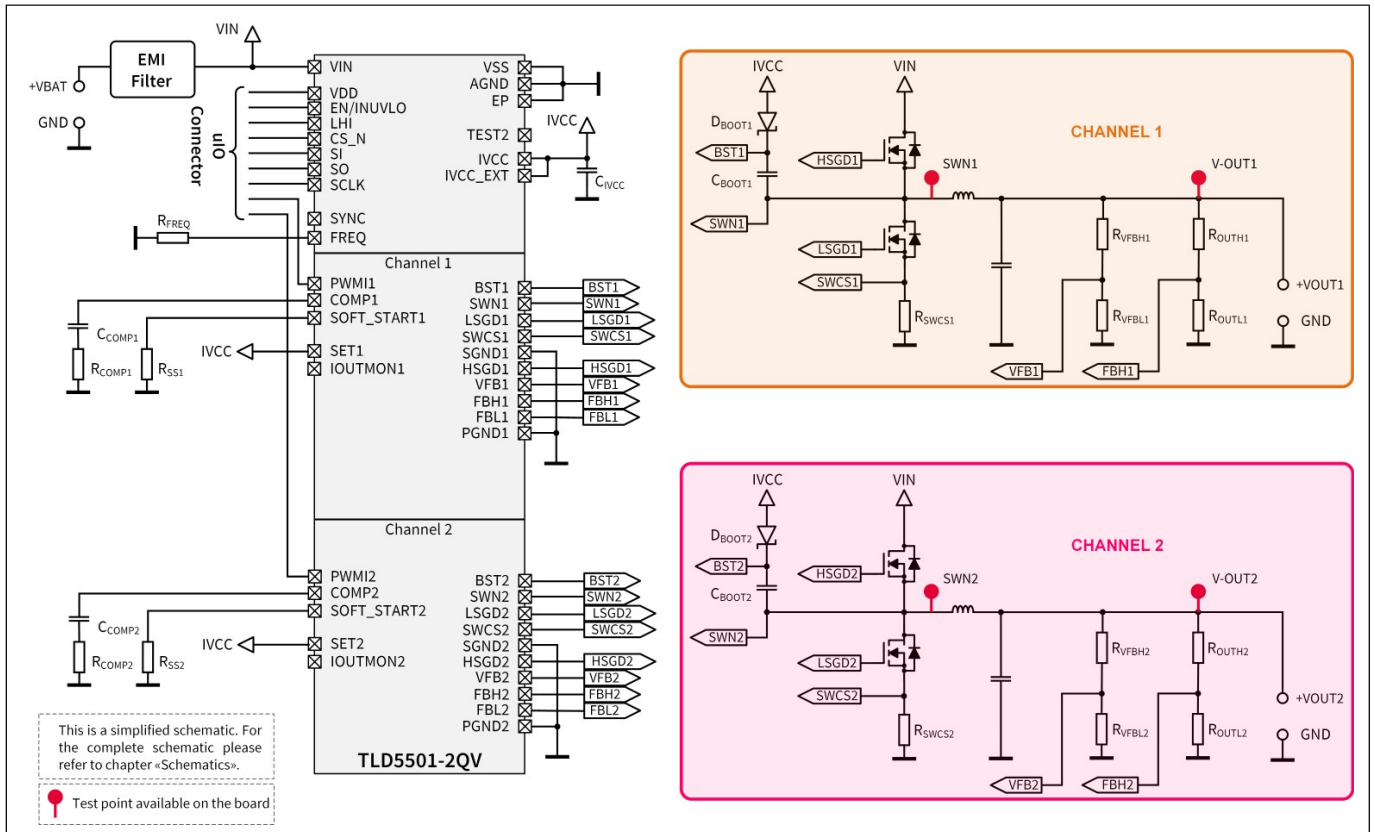

Figure 2 Simplified schematic

Table 1 Performance summary

Parameter	Conditions	Value
Input supply voltage	Parameter degradation below 8 V	8 to 26 V
Max output voltage	Analog dimming = 100%	5.0 V
Nominal output voltage	Analog dimming = 90%	4.5 V
Min output voltage	Analog dimming = 0%	0.0 V
Output current	–	2 x 12 A
Peak output current limit	Peak duration ≤ 1 s, V _{BATT} ≥ 8 V	2 x 25 A
Switching frequency	Set by R _{FREQ} = 25.5 kΩ	400 kHz
Efficiency	V _{BATT} = 12 V, V _{OUT} = 4.5 V, I _{OUT} = 12 A EMI filter bypassed Spread spectrum off	> 95%
Output overvoltage protection	–	5.5 V
Maximum ambient temperature	With heatsinks mounted to the bottom	85°C

2 Quick start procedure

2 Quick start procedure

Connect the input power supply with 4 mm banana plugs to the input connectors named V-IN and GND. Connect the ADB light sources with 4 mm banana plugs to the output connectors named V-OUT1 and GND for channel 1 and V-OUT2 and GND for channel 2, as shown in Figure 3.

Attention: The input current can reach 25 A in normal operation, especially when the input is driven with low voltages (< 12 V). Make sure that the cross section of the input cables is adequate for the current to be handled. It is recommended to use a cross section not smaller than 2.5 mm² for input and output connections.

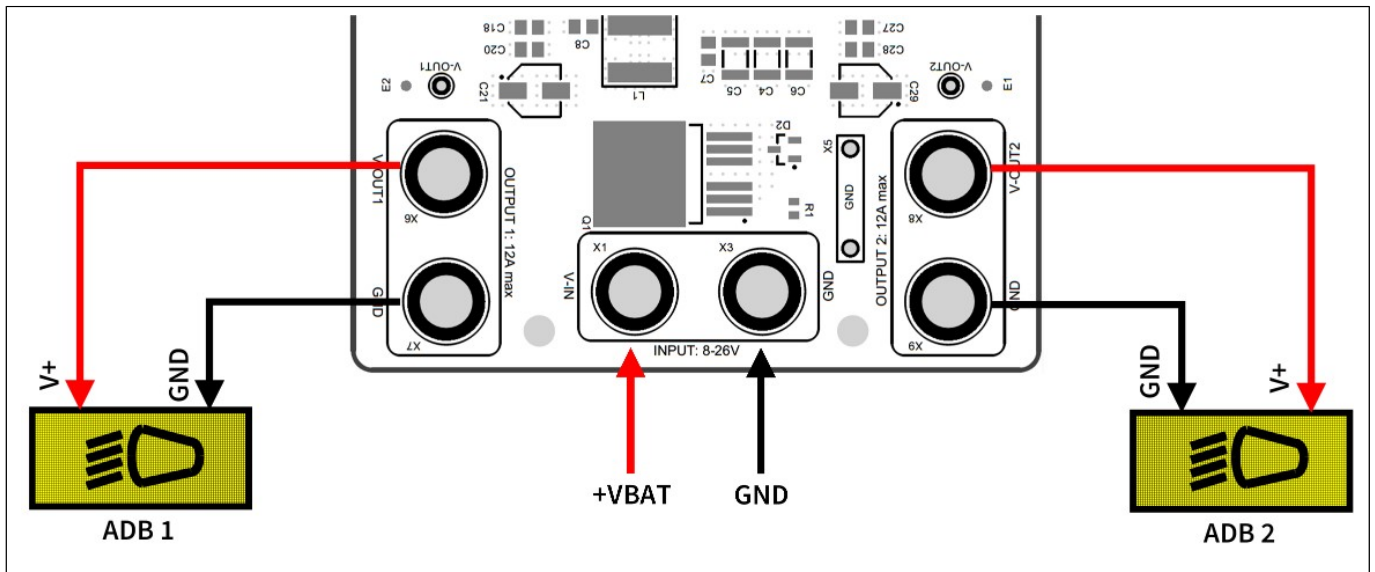

Figure 3 Input/output connection

TLD5501-2ADBPREF board comprises three solder jumpers that are useful to perform current measurements.

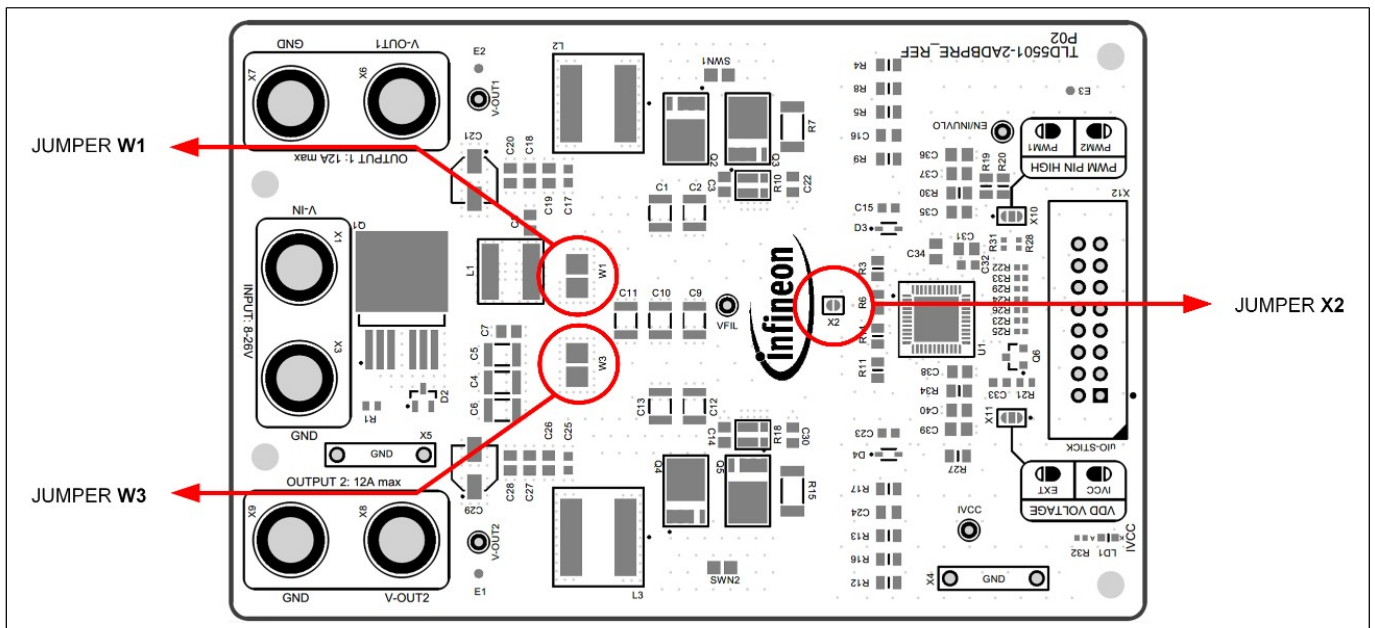

Figure 4 Jumpers for current measurements

2 Quick start procedure

Table 2 Jumpers for current measurement

Current jumper	Function
W1	Interrupt power input of CHANNEL 1
W3	Interrupt power input of CHANNEL 2
X2	Interrupt V_{IN} input of TLD5501-2QV

Note: Solder all jumpers of Table 2 to turn on the board

TLD5501-2ADBPREF board is designed to also work in standalone mode, without any external controller need. With this configuration it is not possible to adjust the output voltage that is fixed to 5 V.

For standalone configuration, it is necessary to solder:

- All three terminals of solder jumper X10 to force pins PWM1,2 to high and enable both outputs
- Terminals 2 and 3 of solder jumper X11 to connect to IVCC (5 V typical) the digital supply voltage

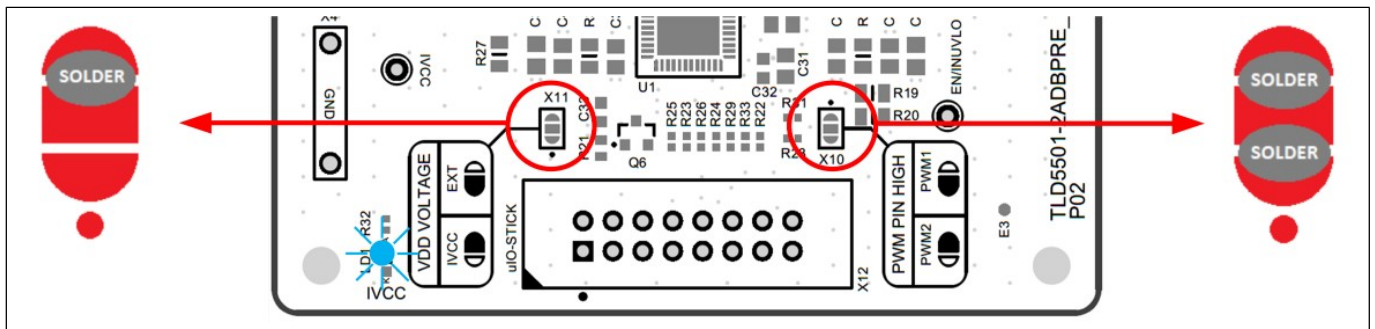

Figure 5 Jumper soldering for standalone configuration

If IVCC voltage is present and the converter works correctly, the IVCC blue LED will light up.

3 Board control with PC GUI

3 Board control with PC GUI

By controlling the TLD5501-2QV with its SPI interface, it is possible to vary the output voltage from 0 V to 5 V. Find the intuitive and user-friendly visual interface (GUI) on the Infineon Developer Center which communicates with the board through an adapter, the Infineon μ IO-stick [1].

Before connecting the μ IO-stick to the board, be sure that:

- Both terminals of solder jumper X10 are open
- Solder jumper X11 is close in 1-2 position, in order to connect the digital power supply of the controller to the μ IO-stick power supply output

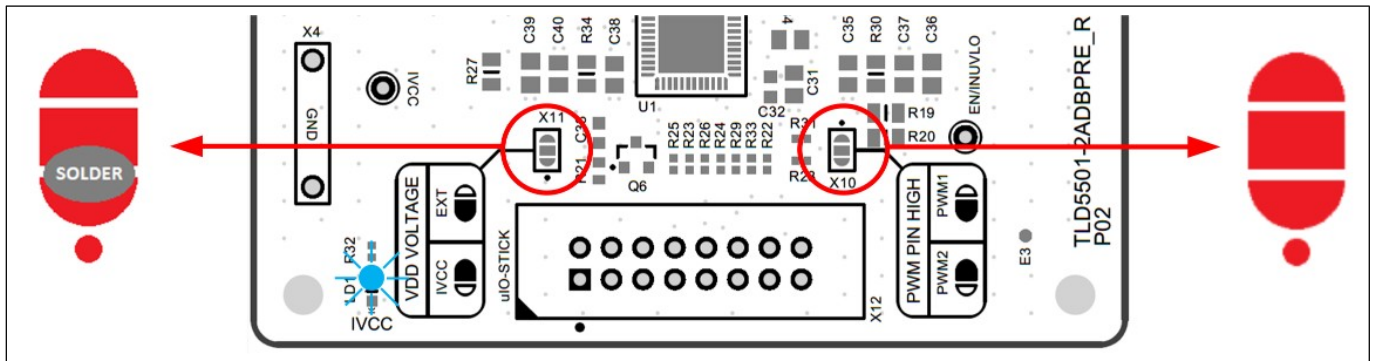

Figure 6 Jumper soldering for controlling board with μ IO stick

Connect the μ IO-stick to the 16-pin IDC connector X12 using the flat cable and then to the PC via USB port, as shown in the figure below.

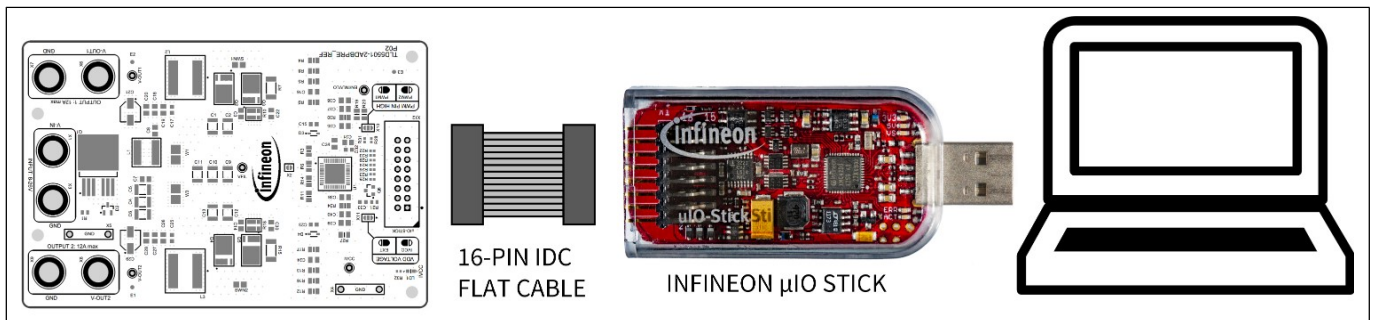

Figure 7 Infineon μ IO-stick connection

See [Chapter 4](#) to learn more about Infineon μ IO-stick [1] and Infineon Developer Center [2].

4 Infineon μ IO-Stick and Developer Center Launcher

4 Infineon μ IO-Stick and Developer Center Launcher

The Infineon μ IO-stick [1] is an interface device for controlling Infineon boards/kits during run time through PC.

- Enables the communication between the reference board and the PC GUI via SPI using the Config Wizard software, which can be downloaded via the Infineon Developer Center [2]
- Plugs into the reference board via a standard 16-pin connector and allows easy interface to the microcontroller via USB for SPI, CAN, LIN communication

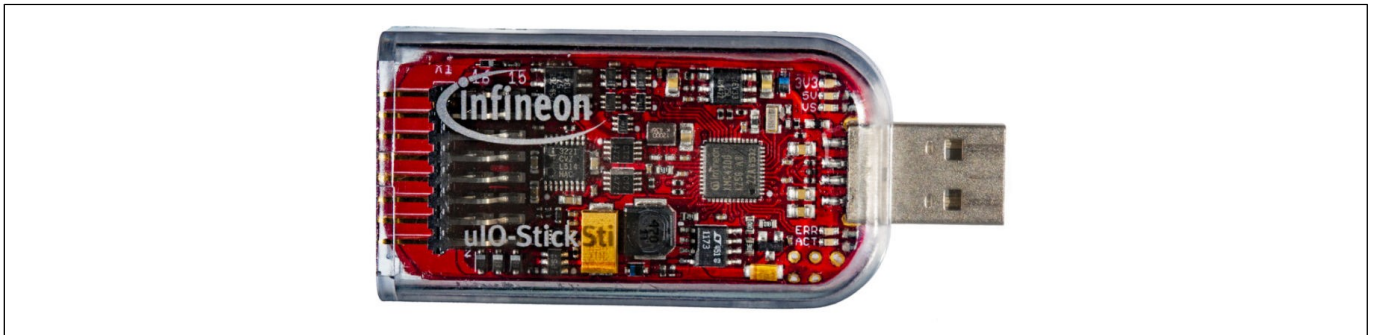

Figure 8 Infineon μ IO-Stick

The Infineon Developer Center [3] is a single platform interface which allows:

- Quick installation of tools by name or QR code
- Help with documentation
- Viewing and starting installed tools from built-in launcher
- Receiving update notifications

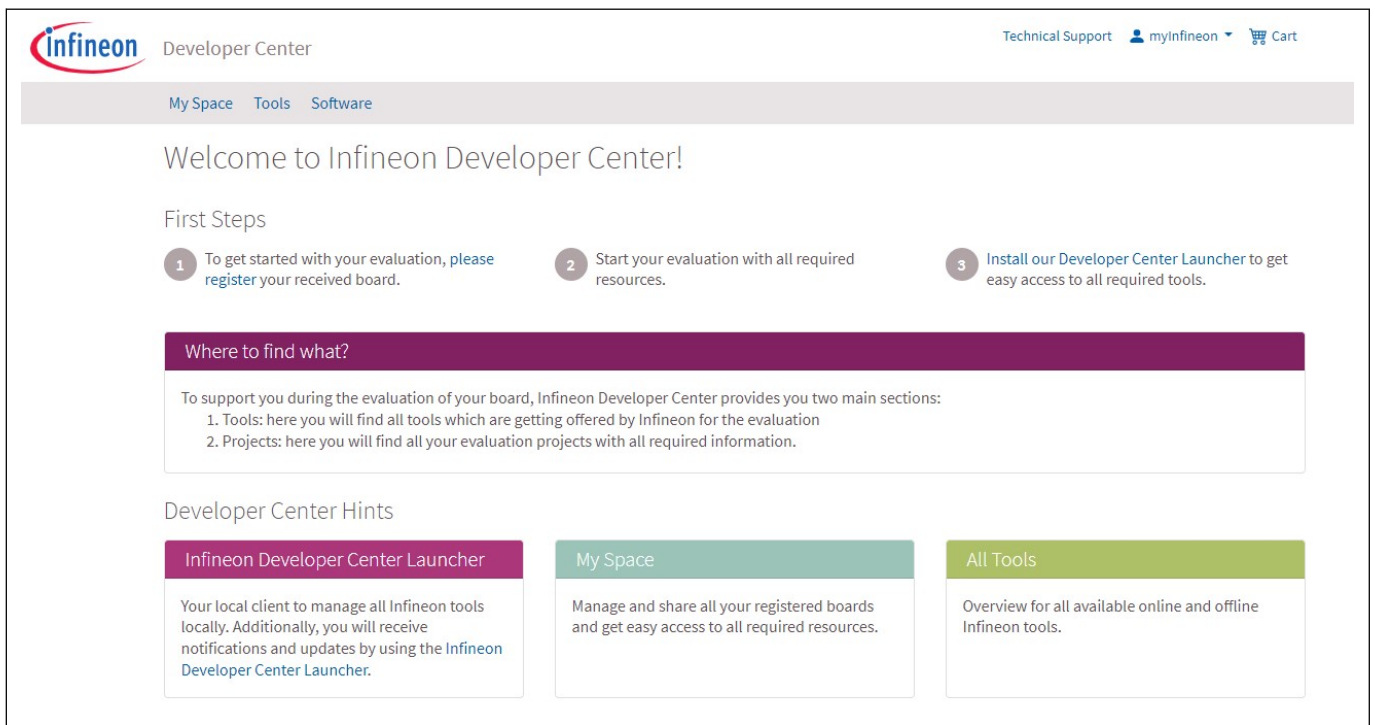

Figure 9 Infineon Developer Center

5 Installing the graphical user interface (GUI)

5 Installing the graphical user interface (GUI)

Steps

1. Install the Infineon Developer Center Launcher at the website Infineon Developer Center .
2. Run the Infineon Developer Center Launcher and click **Manage Tools**.



Figure 10 Manage tools

3. Then search for Config Wizard for LED and click **Install**.

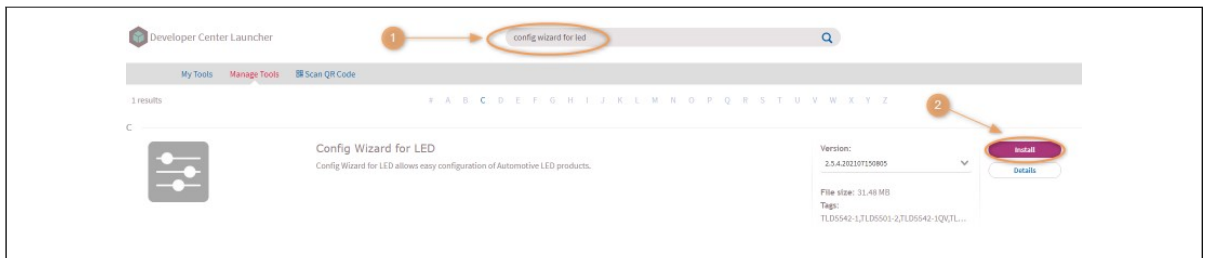

Figure 11 Install Config Wizard for LED

4. When the installation is complete, select **My Tools**.
5. Click **Config Wizard for LED** panel, click **Start**.

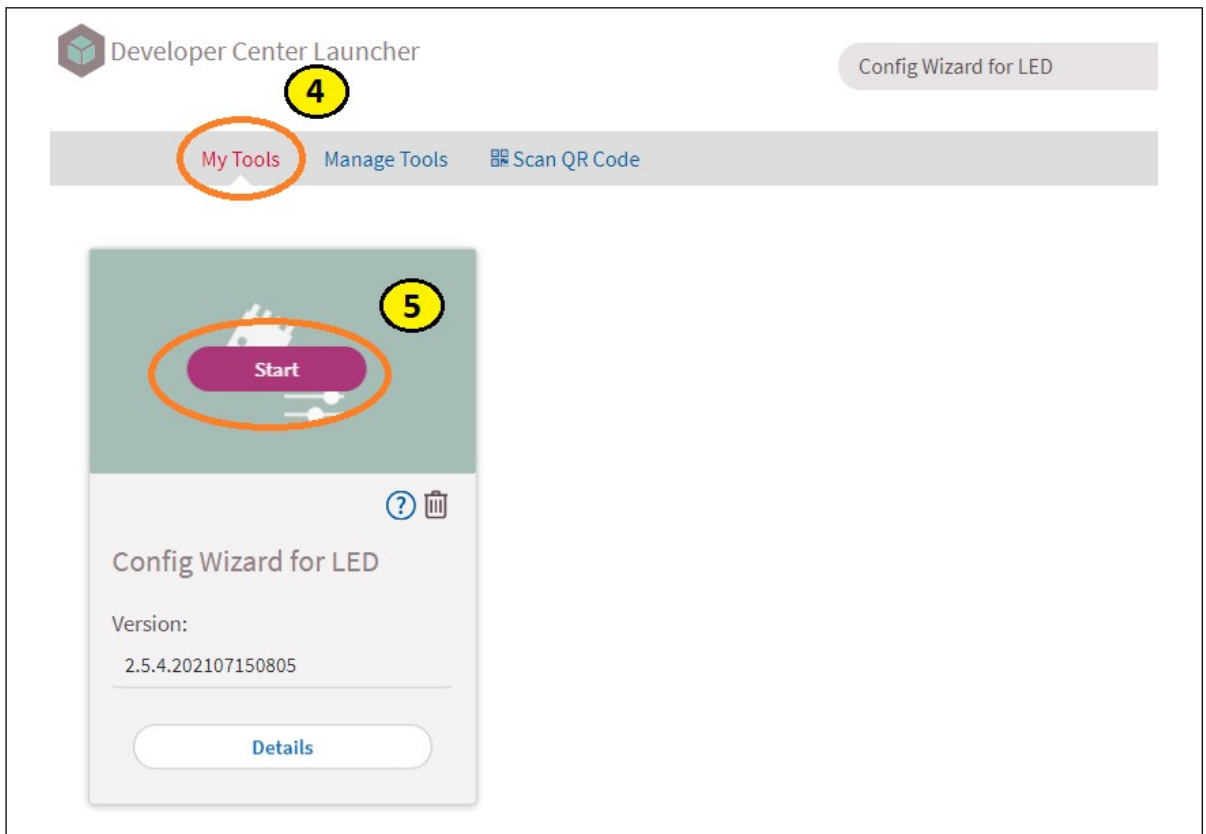

Figure 12 Starting tool

5 Installing the graphical user interface (GUI)

- 6. Click **TLD5501-2QV** to start the LED GUI interface.

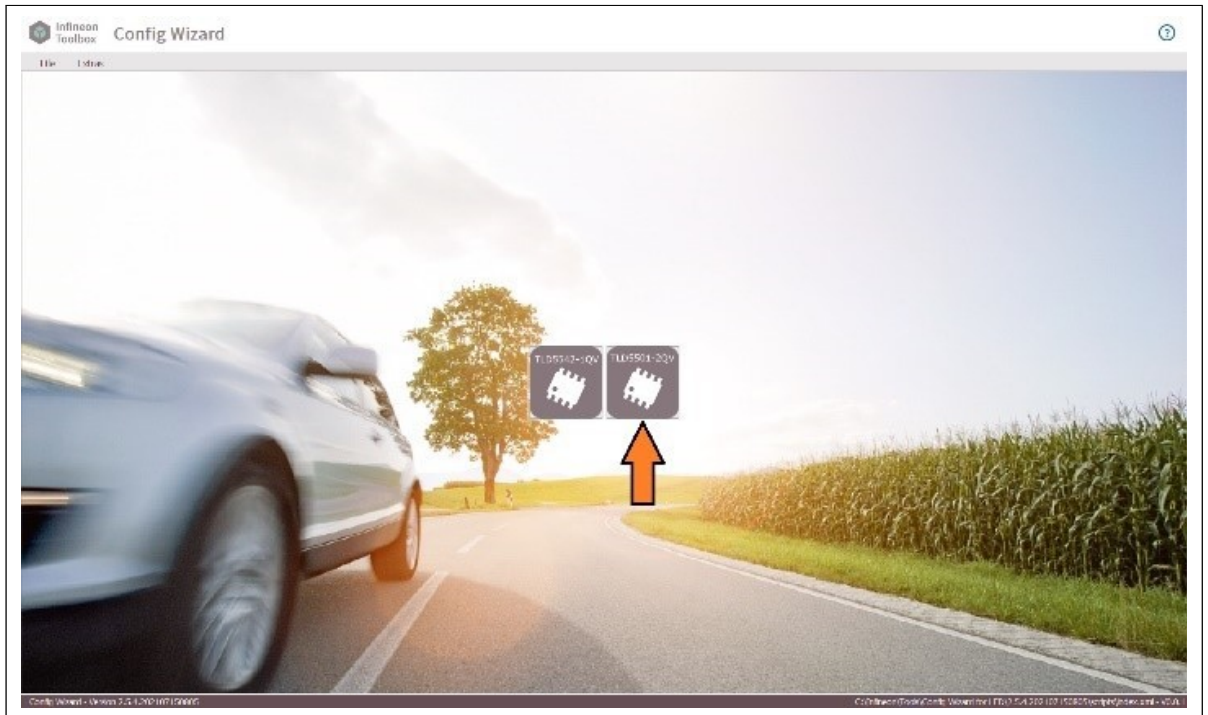

Figure 13 **Launch TLD5501-2QV GUI**

6 TLD5501-2QV GUI

6 TLD5501-2QV GUI

The GUI works only if the TLD5501-2ADBPREF board is correctly connected to the μ IO-stick and properly supplied. Be sure that board configuration has been set up as described in Chapter 3.

Once the TLD5501-2QV LED GUI interface has been launched, the following interface will appear (if a different view is shown, click on tab “Basic” as indicated by the arrow number 1 in the figure below).

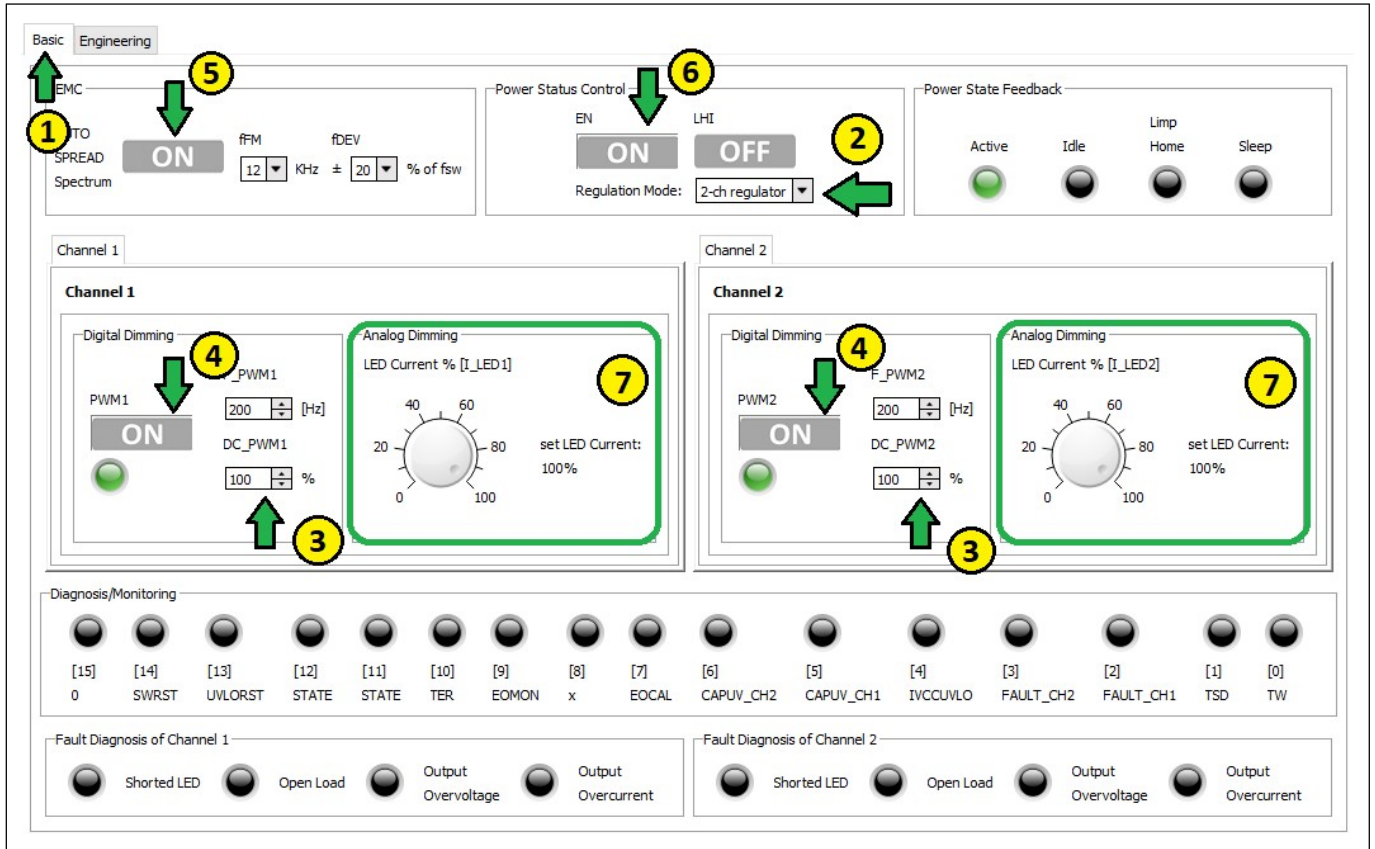

Figure 14 TLD5501-2QV GUI – Basic user interface

Refer to the figure above and follow the steps below.

Steps

1. Click tab **Basic**
2. Select **2-ch regulator** at **Regulation Mode**, to make the two channels work independently
3. Set **100%** of digital dimming on both channels
4. Select **ON** for the digital dimming on both channel
5. Enable or disable the **Spread Spectrum** function to reduce EM emissions (enabled by default)
6. Click **ON** for EN button to turn on both channels
7. **Analog Dimming** knobs allow adjustment of the output voltage for each channel

7 Schematics

7 Schematics

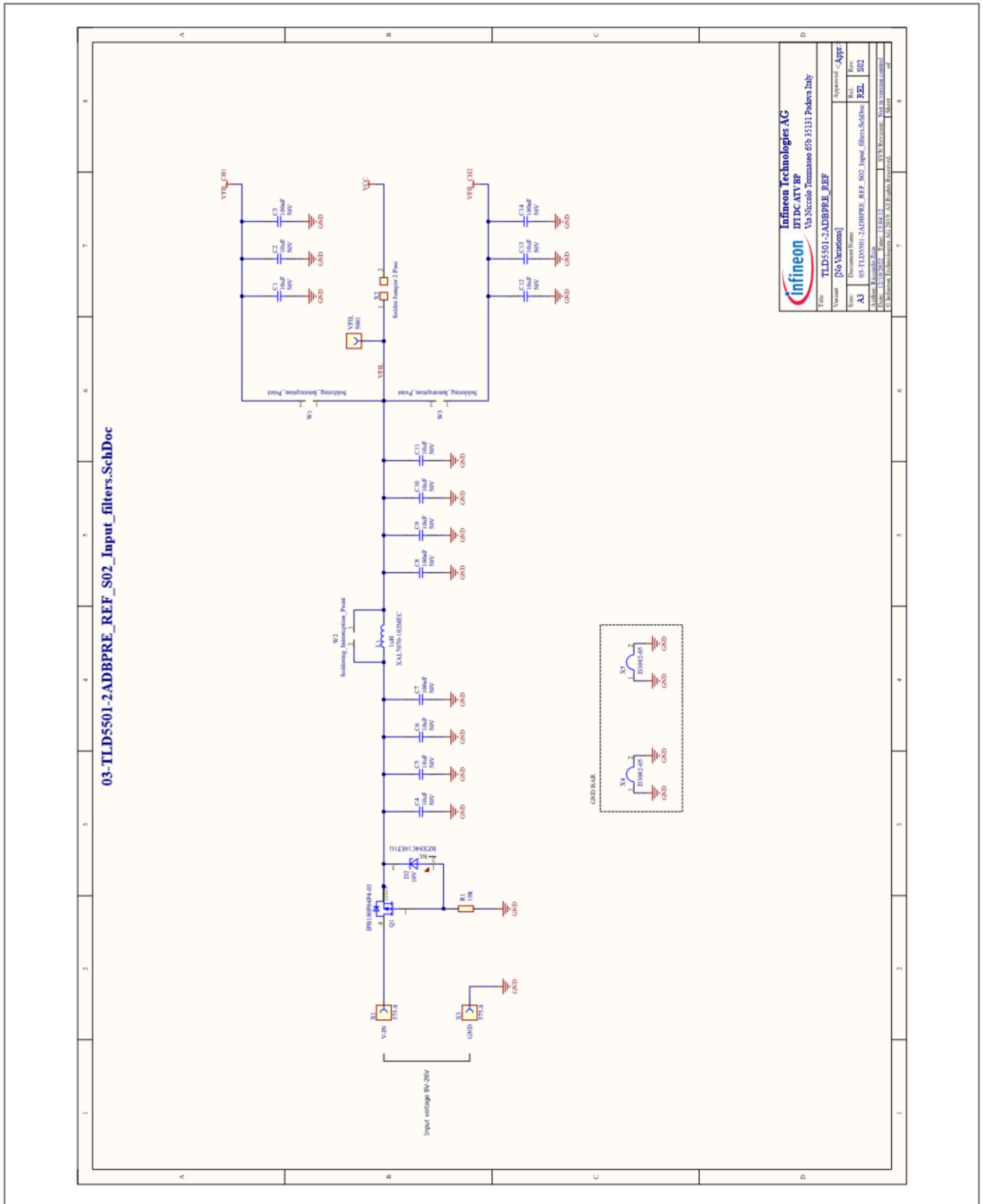

Figure 15 Input filters

7 Schematics

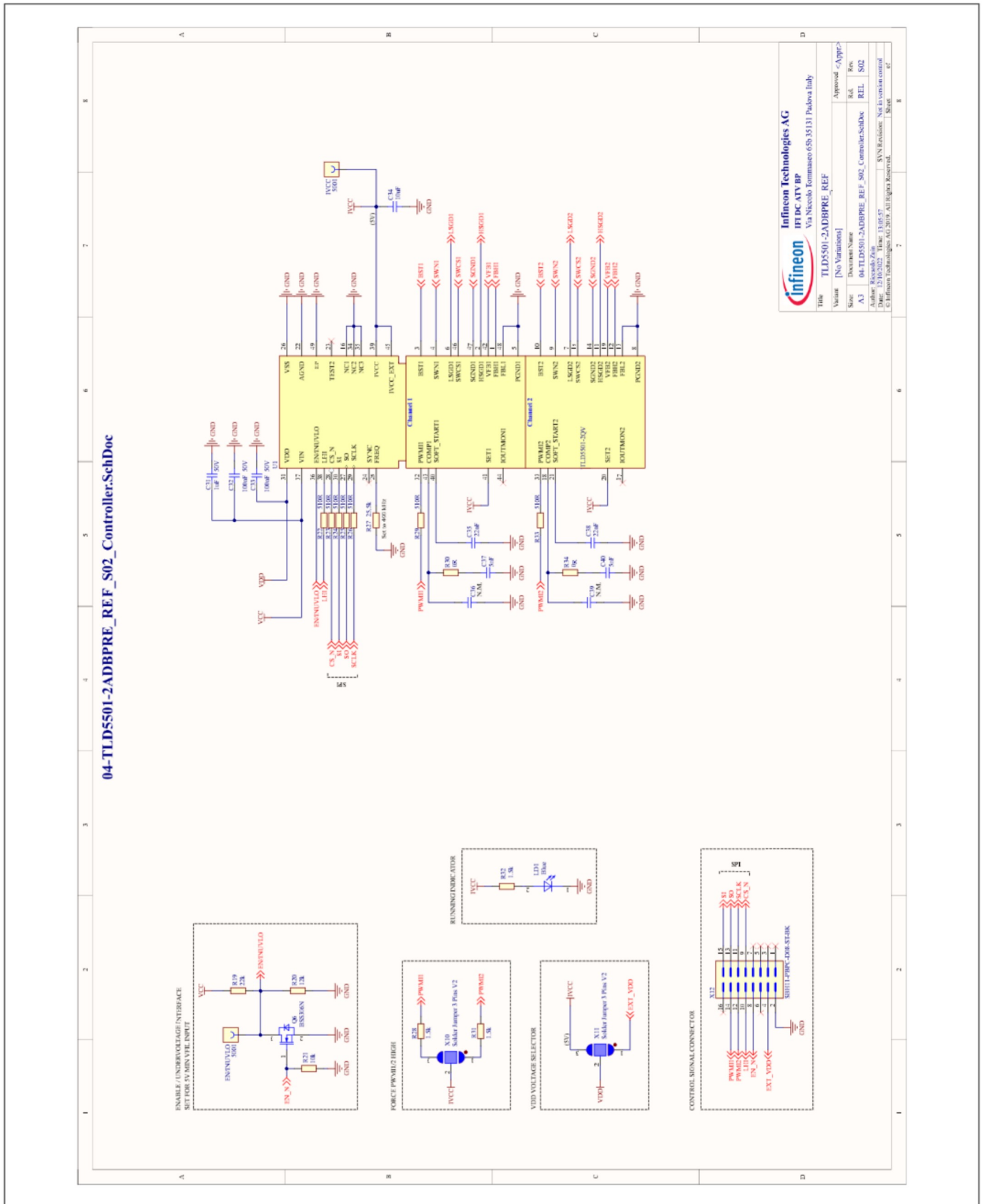

Figure 16 Controller

7 Schematics

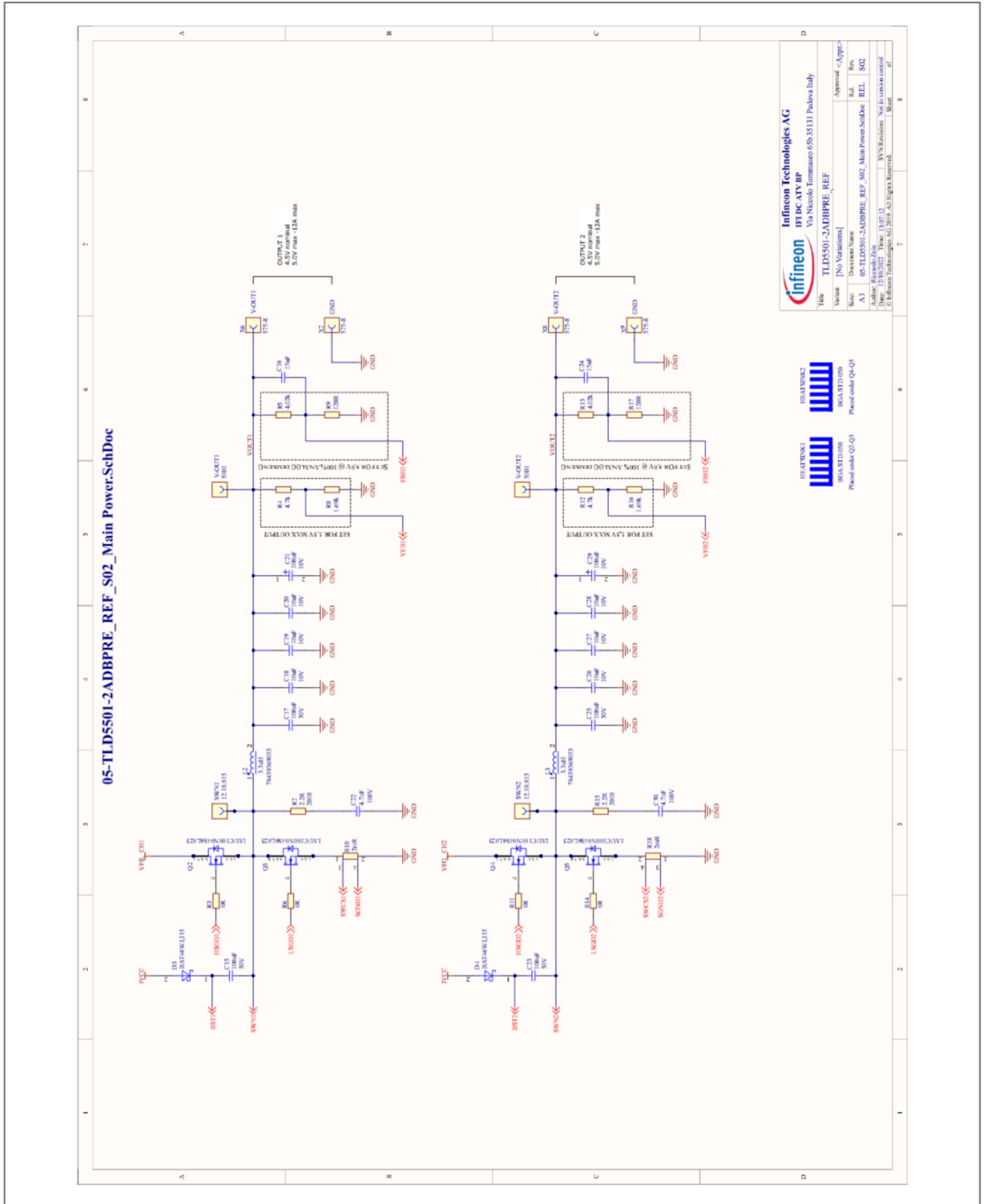

Figure 17 Main power

8 PCB layout

8 PCB layout

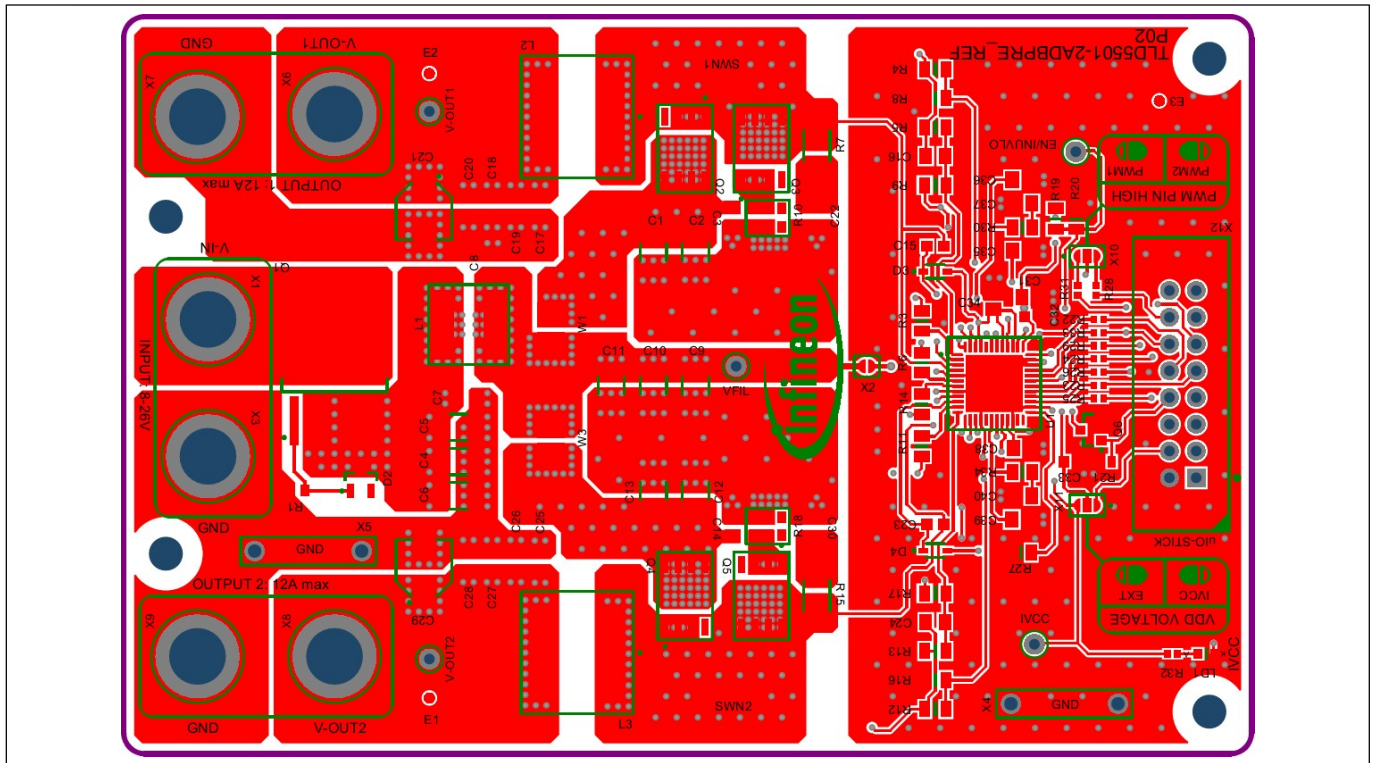

Figure 18 Top overlay

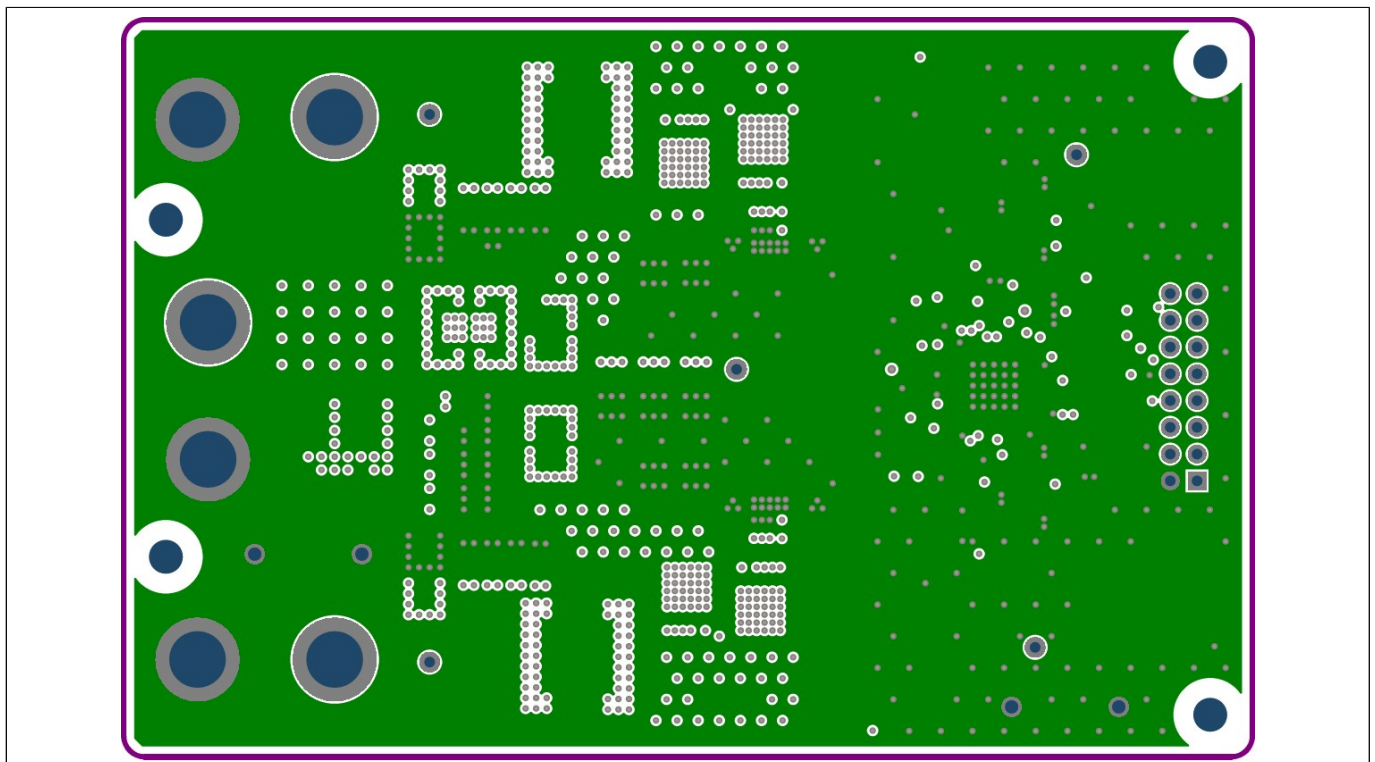

Figure 19 Internal overlay 1 - GND plane

8 PCB layout

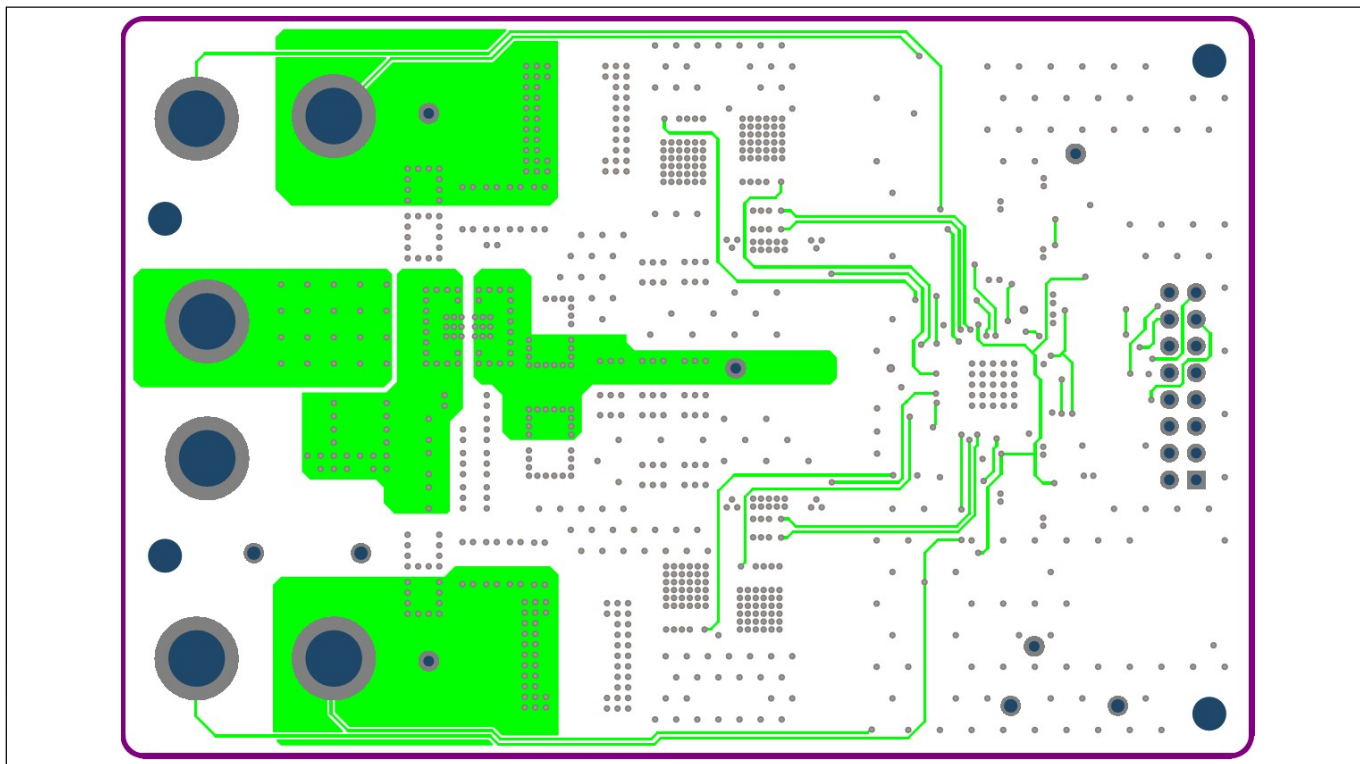

Figure 20 Internal overlay 2

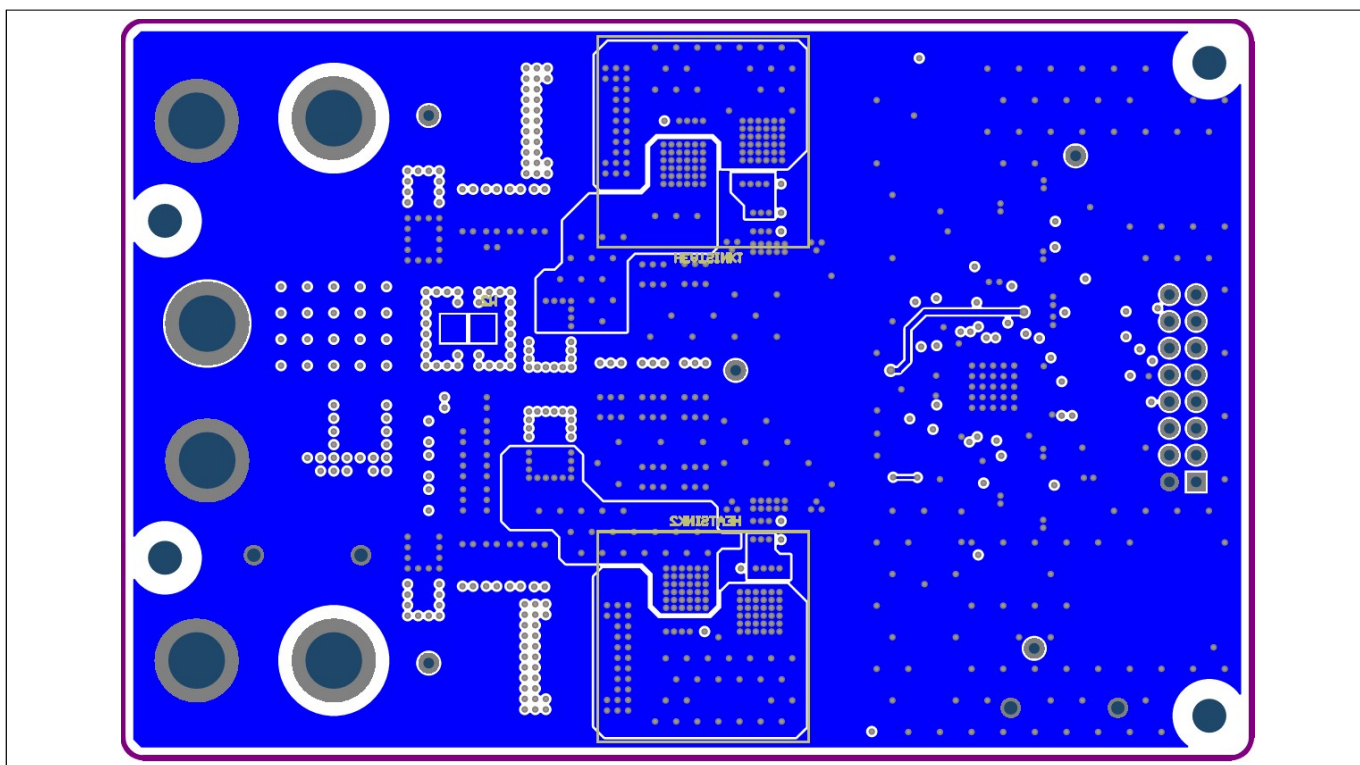

Figure 21 Bottom overlay

9 Bill of material

9 Bill of material

Table 3 Bill of material

Designator	Value	Manufacturer	Manufacturer order number
C1, C2, C4, C5, C6, C9, C10, C11, C12, C13	10 uF	MuRata	GRM32ER71H106MA12
C3, C7, C8, C14	100 nF	TDK Corporation	CGA4J2X8R1H104K125AA
C15, C17, C23, C25, C32, C33	100 nF	Kemet	C0603C104K5RACAUTO
C16, C24	15 nF	MuRata	GCM216R72A153KA37
C18, C19, C20, C26, C27, C28	10 µF	TDK Corporation	CGA4J1X8L1A106K125AE
C21, C29	100 µF	Nichicon	PCG1A101MCL1GS
C22, C30	4.7 nF	MuRata	GCM216R72A472MA37
C31	1 µF	TDK Corporation	CGA4J3X7R1H105K125AB
C34	10 µF	TDK Corporation	CGA4J1X7R0J106K125AC
C35, C38	22 nF	TDK Corporation	CGJ4J2C0G1H223J125AA
C36, C39	1 nF	TDK Corporation	CGA4F2X7R2A102M085AE
C37, C40	5 nF	AVX	08055C502KAT2A
D2	10 V	ON Semiconductor	BZX84C10LT1G
D3, D4		Nexperia	BAT46WJ,115
EN/INUVLO, IVCC, VFIL, V-OUT1, V-OUT2		Keystone Electronics Corp.	5001
HEATSINK1, HEATSINK2		ABL Components	BGA STD 050
L1	1 µH	Coilcraft	XAL7070-102MEC
L2, L3	3.3 µH	Würth Elektronik	78439369033
LD1	Blue	Würth Elektronik	150060BS75000
Q1		Infineon Technologies	IPB180P04P4-03
Q2, Q3, Q4, Q5		Infineon Technologies	IAUC100N04S6L025
Q6		Infineon Technologies	BSS306N
R1, R21	10 kΩ	Vishay	CRCW060310K0FK
R3, R6, R11, R14, R30, R34	0 Ω	Vishay	CRCW08050000Z0EAHP
R4, R12	4.7 kΩ	Vishay	CRCW08054K70FK
R5, R13	4.02 kΩ	Vishay	CRCW08054K02FK
R7, R15	2.2 Ω	Vishay	CRCW20102R20FK
R8, R16	1.69 kΩ	Vishay	CRCW08051K69FK
R9, R17	120 Ω	Vishay	CRCW0805120RFK
R10, R18	2 mΩ	Vishay	WSKW06122L000FEA
R19	22 kΩ	Vishay	CRCW080522K0FK
R20	12 kΩ	Vishay	CRCW080512K0FK
R22, R23, R24, R25, R26, R29, R33	510 Ω	Panasonic	ERJ2RKF5100X

(table continues...)

9 Bill of material

Table 3 (continued) Bill of material

Designator	Value	Manufacturer	Manufacturer order number
R27	25.5 kΩ	Vishay	CRCW080525K5FK
R28, R31, R32	1.5 kΩ	Vishay	CRCW04021K50FK
SWN1, SWN2		ETTINGER	12.18.815
U1		Infineon Technologies	TLD5501-2QV
X1, X3, X6, X7, X8, X9		Keystone Electronics Corp.	575-8
X2		Infineon Technologies	Solder Jumper 2 Pins
X4, X5		Harwin	D3082-05
X10, X11		Infineon Technologies	Solder Jumper 3 Pins V2
X12		Sullins	SBH11-PBPC-D08-ST-BK

10 Electrical performance

10 Electrical performance

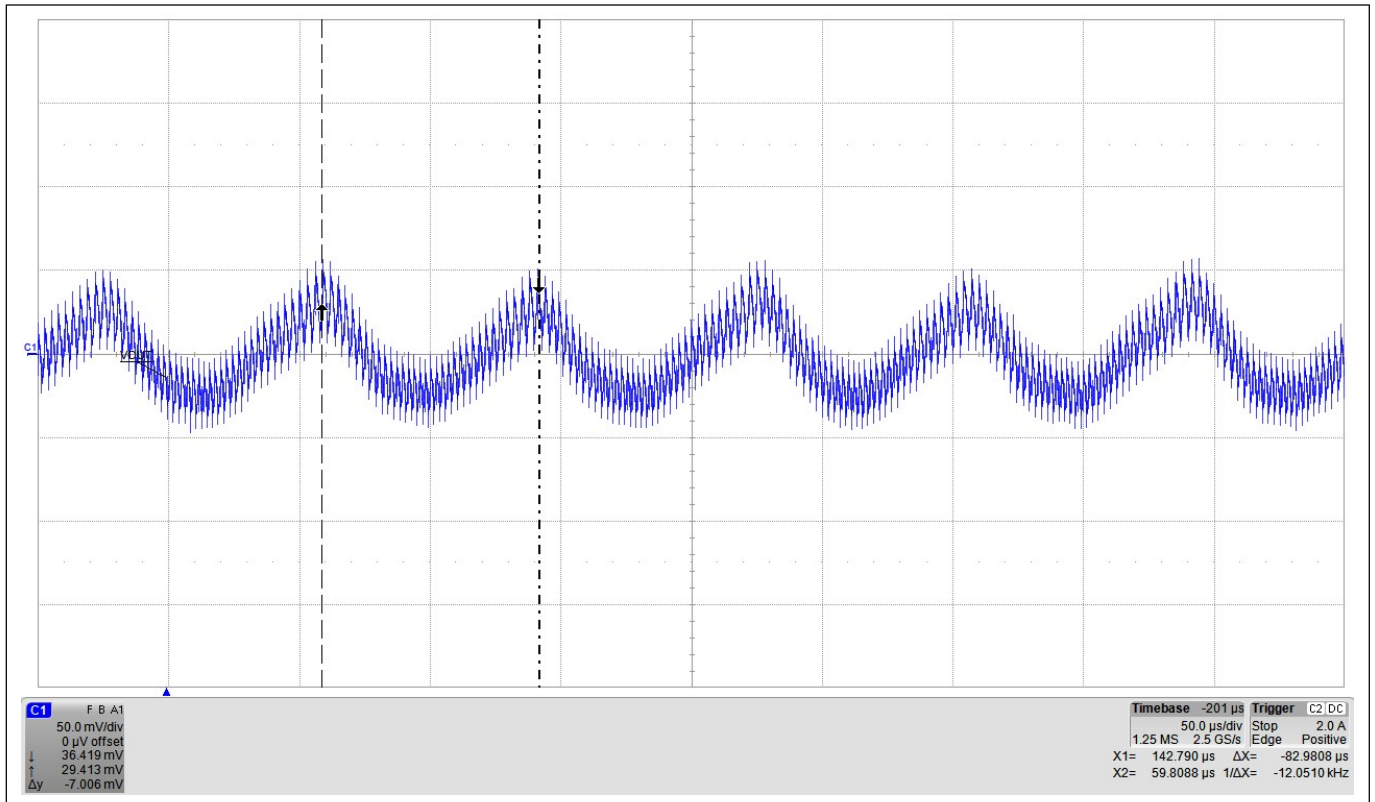

Figure 22 Output voltage ripple ($V_{IN} = 12\text{ V}$, $V_{OUT} = 5\text{ V}$, $I_{OUT} = 0\text{ A}$ to 12 A , Spread spectrum ON)

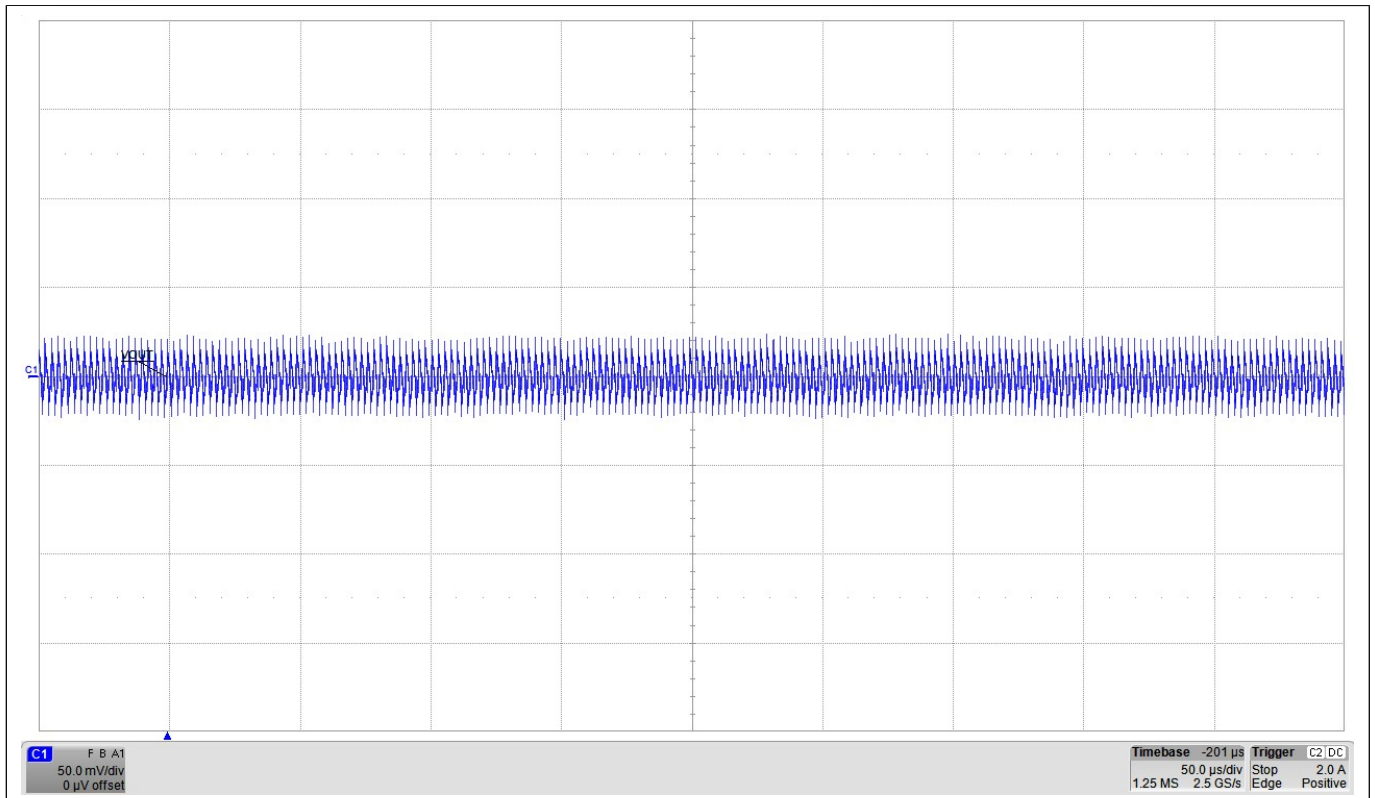

Figure 23 Output voltage ripple ($V_{IN} = 12\text{ V}$, $V_{OUT} = 5\text{ V}$, $I_{OUT} = 0\text{ A}$ to 12 A , Spread spectrum OFF)

10 Electrical performance

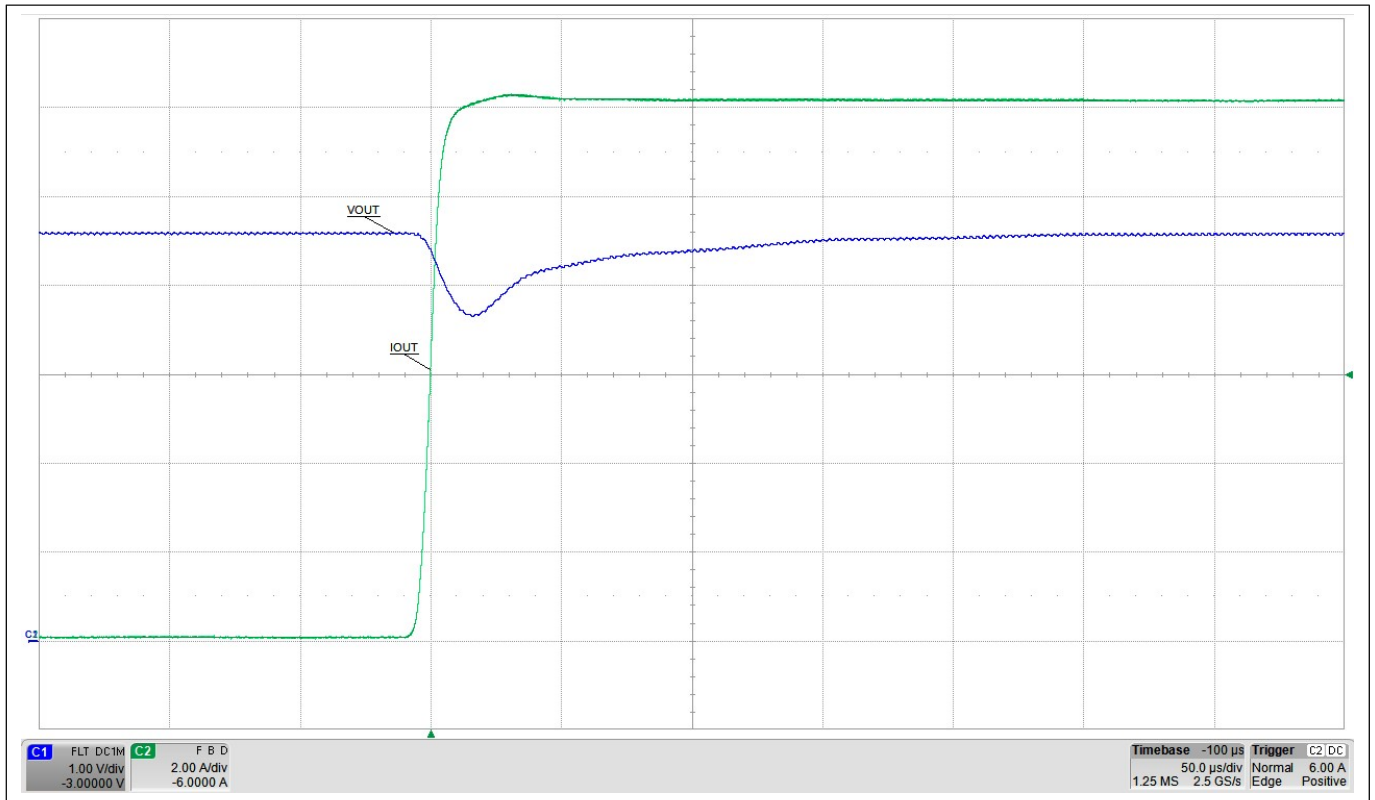

Figure 24 Load dump ($V_{IN} = 12\text{ V}$, $V_{OUT} = 4.5\text{ V}$, $I_{OUT} = 0\text{ A}$ to 12 A , Rise time = $10\text{ }\mu\text{s}$)

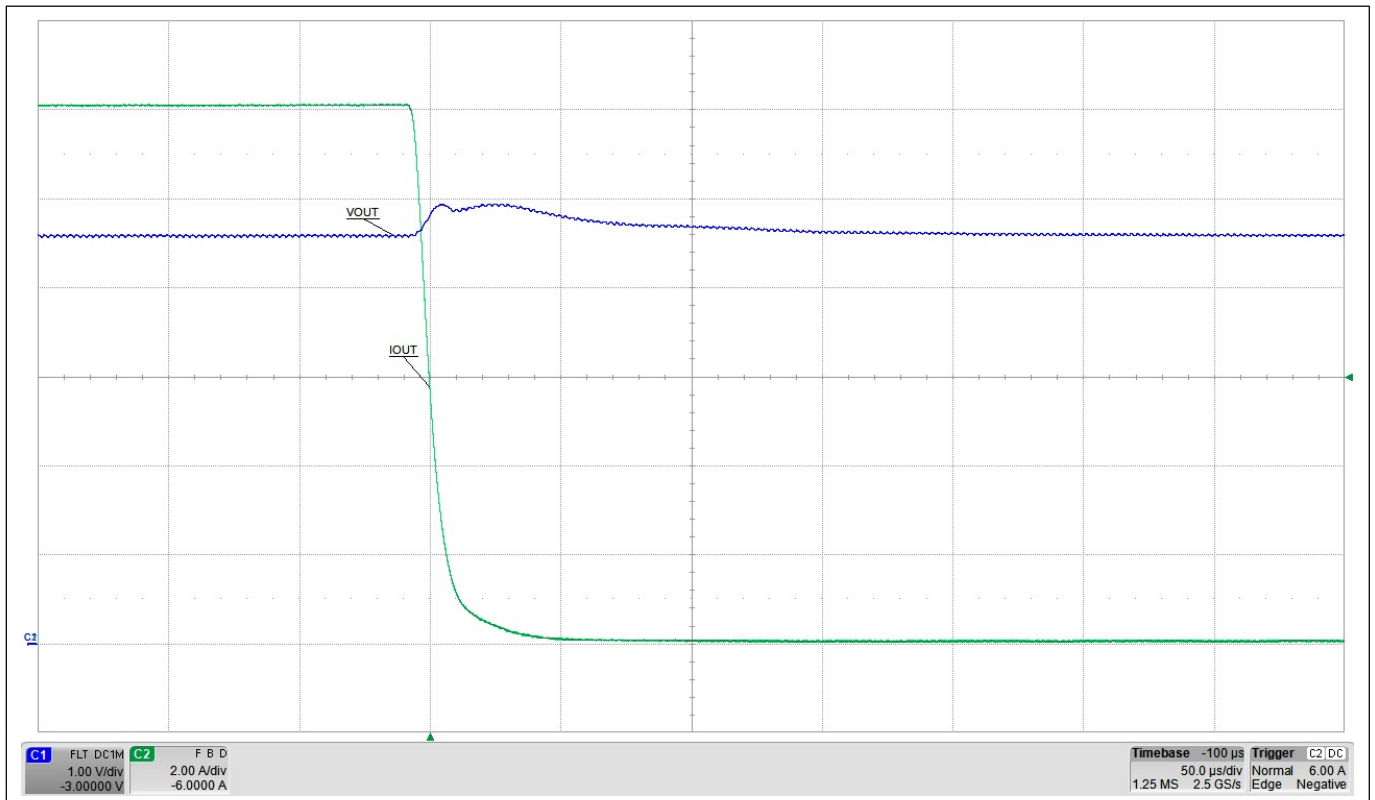

Figure 25 Load dump ($V_{IN} = 12\text{ V}$, $V_{OUT} = 4.5\text{ V}$, $I_{OUT} = 12\text{ to }0\text{ A}$, Fall time = $10\text{ }\mu\text{s}$)

10 Electrical performance

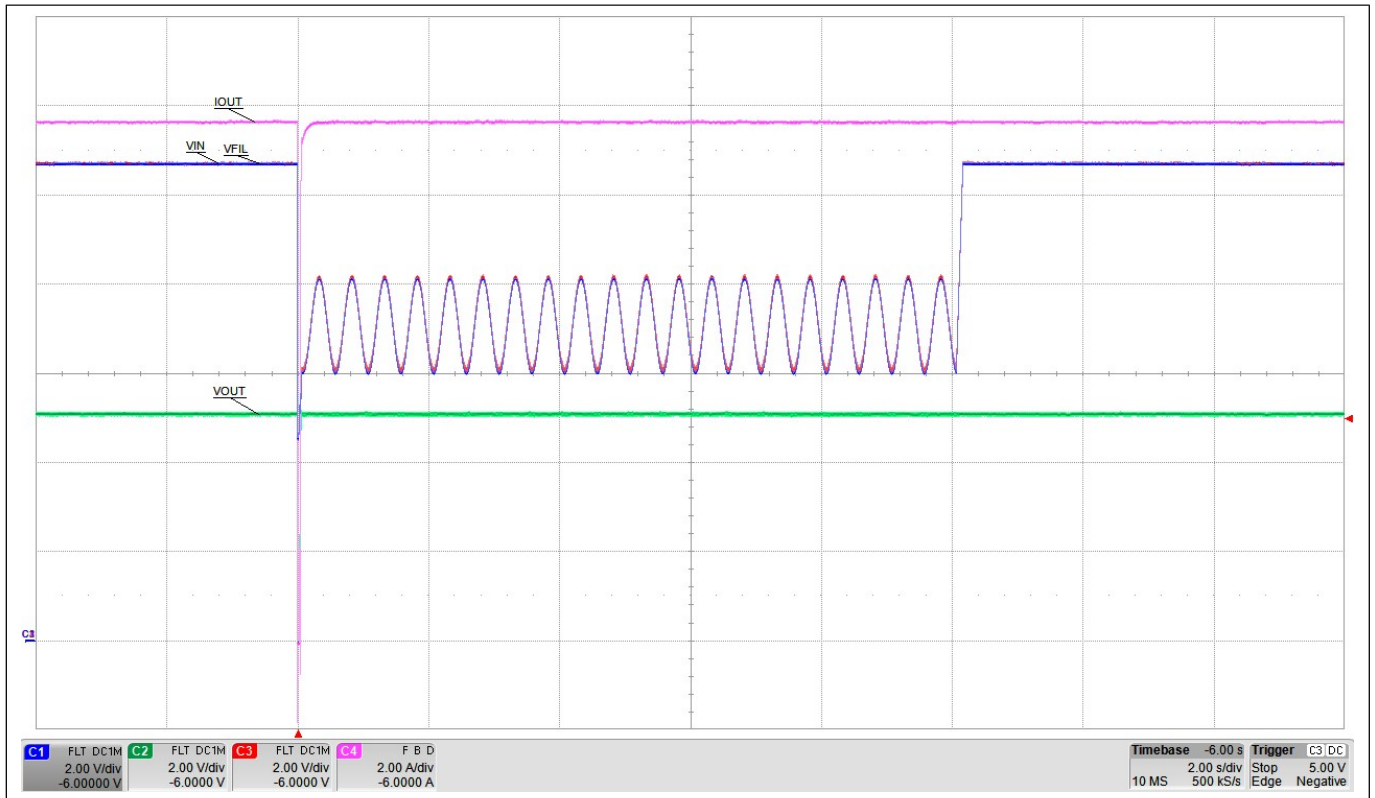

Figure 26 LV124 test E11 Cold Start – Normal (0.4 Ω resistor as output load)

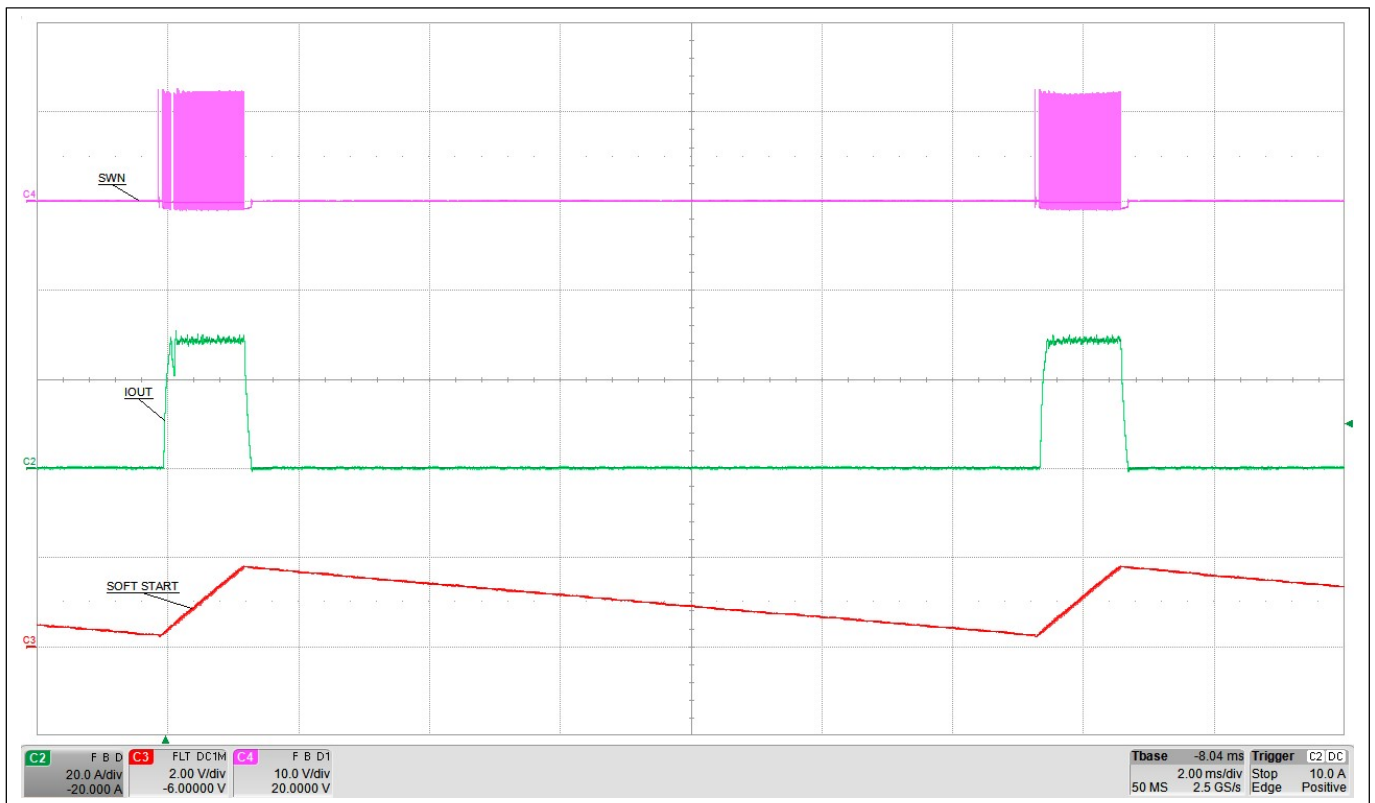

Figure 27 Short to ground ($V_{IN} = 12\text{ V}$)

11 Efficiency measurement

11 Efficiency measurement

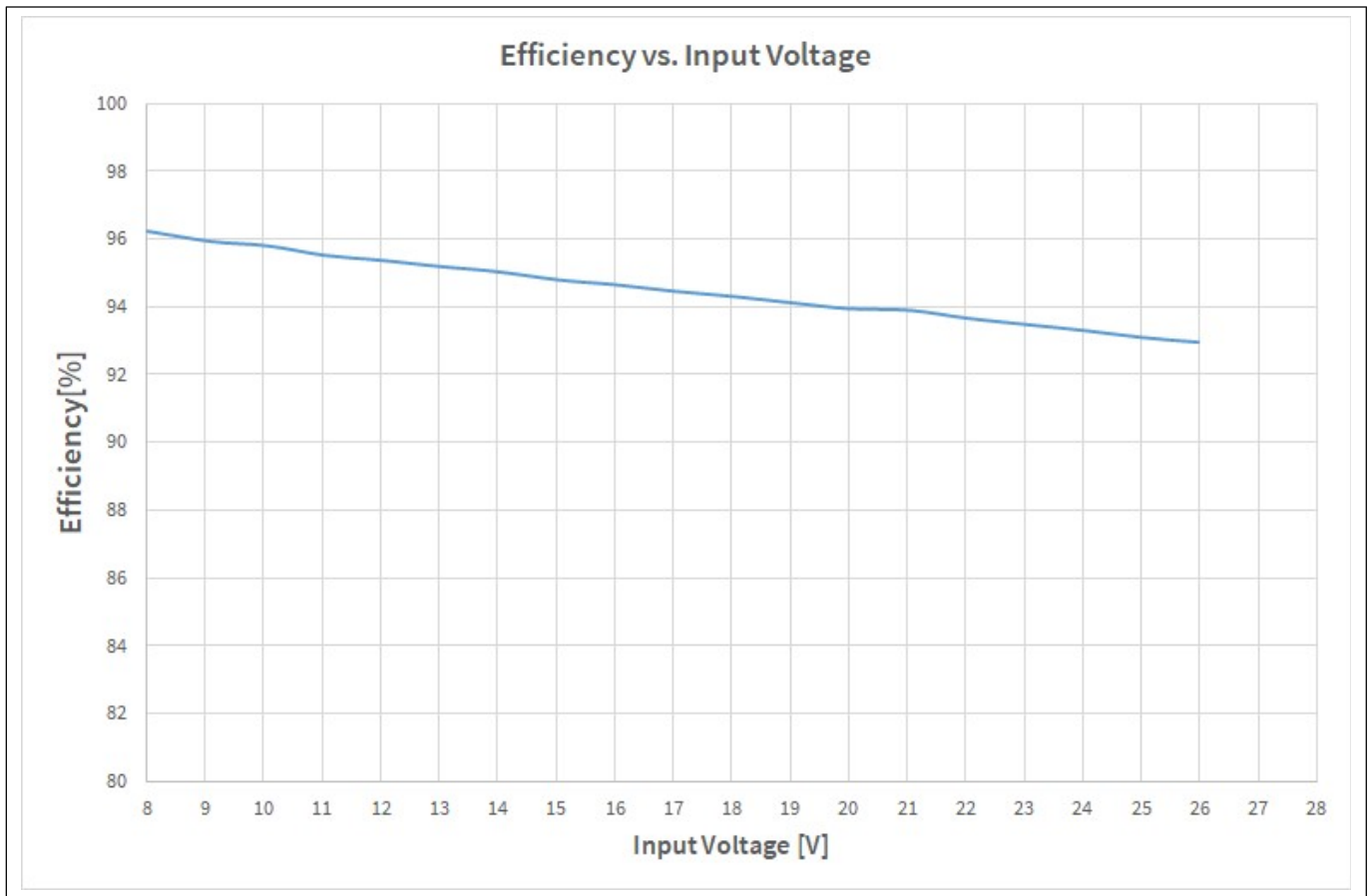

Figure 28 Efficiency versus input voltage performance

Efficiency measurements were calculated with the following data.

Table 4 Efficiency measurement conditions

Output Load	Constant current sink set at 12 A
Output voltage	4.5 V
Ambient temperature	25°C
Spread spectrum	Disabled
EMI filter	Bypassed

References

- [1] Infineon *UIO Stick*; <https://www.infineon.com/cms/en/product/evaluation-boards/uio-stick/>
- [2] Infineon *Developer Center Launcher*; <https://www.infineon.com/cms/en/design-support/tools/utilities/infineon-developer-center-idc-launcher/?redirId=160101>
- [3] Infineon *Developer Center*; https://softwaretools.infineon.com/welcome?_ga=2.11626420.1283798017.1665582717-1592285541.1657005696

Revision history

Revision history

Document version	Date of release	Description of changes
Rev.1.00	2022-10-24	<ul style="list-style-type: none">• First release related to REF_board S02_P02

Trademarks

All referenced product or service names and trademarks are the property of their respective owners.

Edition 2022-10-24

Published by

Infineon Technologies AG

81726 Munich, Germany

© 2022 Infineon Technologies AG

All Rights Reserved.

Do you have a question about any aspect of this document?

Email: erratum@infineon.com

Document reference

IFX-drh1663322851559

For further information on the product, technology, delivery terms and conditions and prices please contact your nearest Infineon Technologies office (www.infineon.com)

Warnings

Due to technical requirements products may contain dangerous substances. For information on the types in question please contact your nearest Infineon Technologies office.

Except as otherwise explicitly approved by Infineon Technologies in a written document signed by authorized representatives of Infineon Technologies, Infineon Technologies' products may not be used in any applications where a failure of the product or any consequences of the use thereof can reasonably be expected to result in personal injury.