

Industrial PROFET™

Universal Application Board
User's Manual

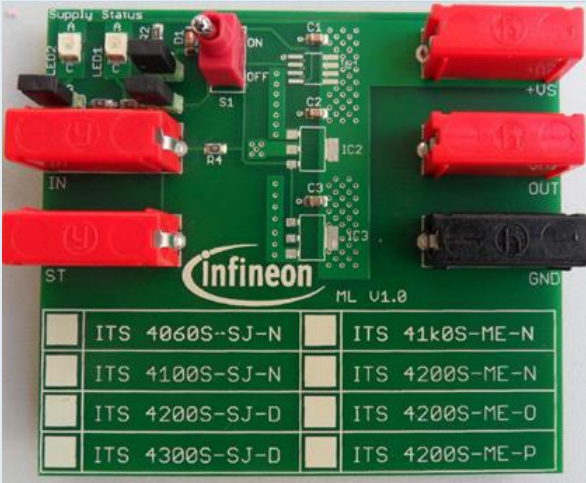

Industrial PROFET™ Universal Application Board

- The Industrial PROFET™ demo board can be used to easily evaluate a wide range of single channel industrial protected high side switches in both PG-SOT-223-4 package as well as the PG-DSO-8 package.
- The demo board comes equipped with external components as well as samples for the devices that can be tested using this universal evaluation board.
- The industrial protected high side switches that can be evaluated using this universal application board are as follows :



PG-DSO-8

ITS4060S-SJ-N
ITS4100S-SJ-N
ITS4200S-SJ-D
ITS4300S-SJ-D

ITS41k0S-ME-N
ITS4200S-ME-N
ITS4200S-ME-O
ITS4200S-ME-P



PG-SOT223-4

Device Details and Ordering Information

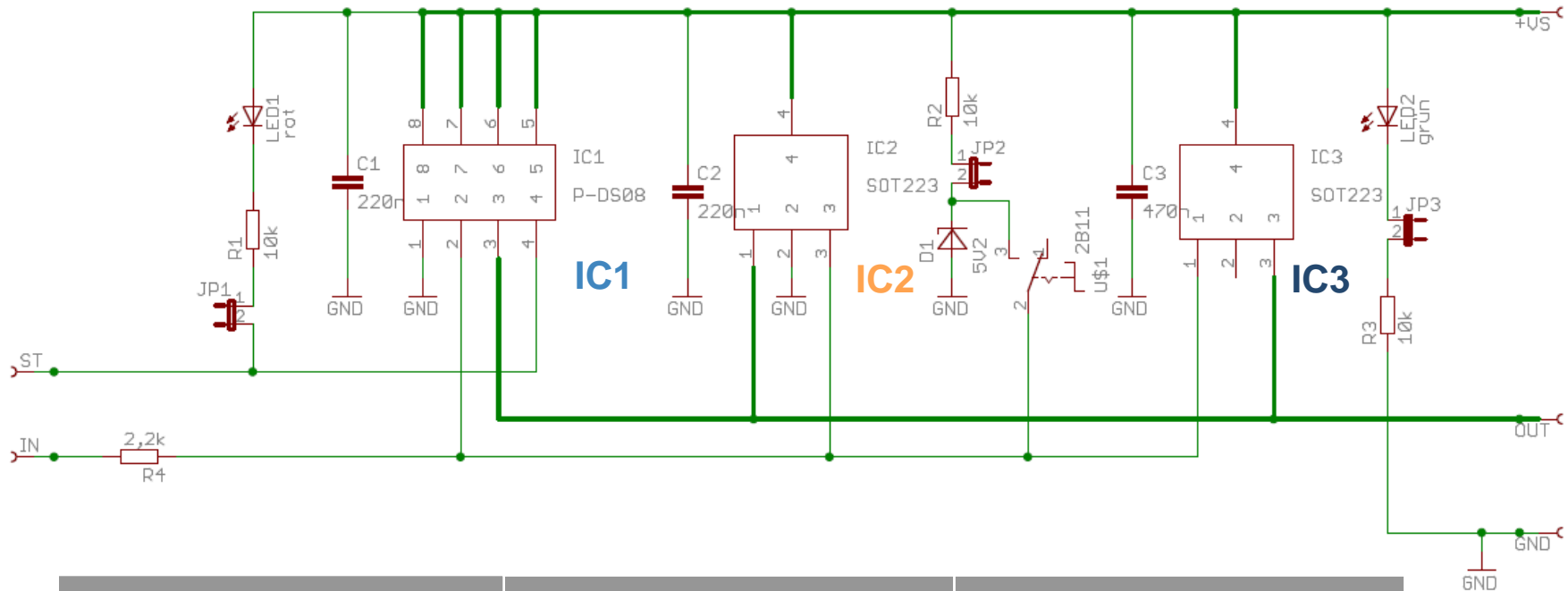

IC1 (PG-DSO-8)	IC2 (PG-SOT223-4)	IC3 (PG-SOT223-4)
ITS4060S-SJ-N	ITS4200S-ME-N	ITS41k0S-ME-N
ITS4100S-SJ-N	ITS4200S-ME-O	
ITS4200S-SJ-D	ITS4200S-ME-P	
ITS4300S-SJ-D		

Device Details and Ordering Information

Device Name	Demo Board Placement	Sample SP Number	$R_{DS(on)}$ (Max.) mΩ	Nominal Load Current (A)	Current Limit (A)	Package
ITS4060S-SJ-N	IC1	SP001007686	120	3.1	10.0	PG-DSO-8
ITS4100S-SJ-N	IC1	SP001007688	200	2.4	17.0	PG-DSO-8
ITS4200S-SJ-D	IC1	SP001007698	350	1.2	6.5	PG-DSO-8
ITS4300S-SJ-D	IC1	SP001006698	480	0.4	1.2	PG-DSO-8
ITS4200S-ME-N	IC2	SP001007692	400	0.7	1.5	PG-SOT223-4
ITS4200S-ME-O	IC2	SP001007694	320	0.7	3.0	PG-SOT223-4
ITS4200S-ME-P	IC2	SP001007696	320	1.4	3.0	PG-SOT223-4
ITS41k0S-ME-N	IC3	SP001006700	3000	0.2	0.9	PG-SOT223-4

Industrial PROFET™ Universal Application Board
 SP # : SP001045762

Industrial PROFET™ Universal Application Board

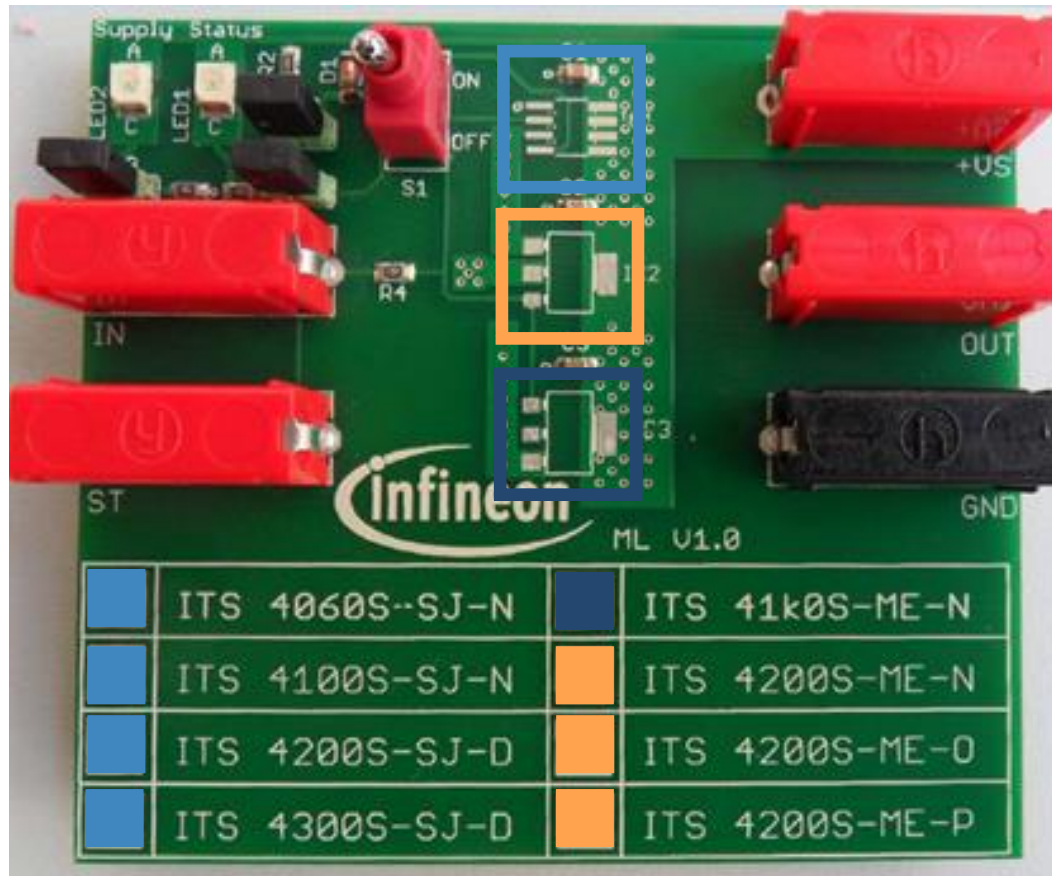

Industrial PROFET™ Universal Application Board (Set Up)



Solder IC to be tested either at IC1, IC2 or IC3
Please refer to list on Page 3.

Connect Supply Voltage at +VS, Connect Jumper JP3 for indication of supply voltage. LED2 (Green) turns ON when a supply voltage is available on board.

Connect Voltage for gate control at IN, e.g. Output from a microcontroller
For more details on input threshold levels, please refer to the datasheet of the device under test on the Infineon website.

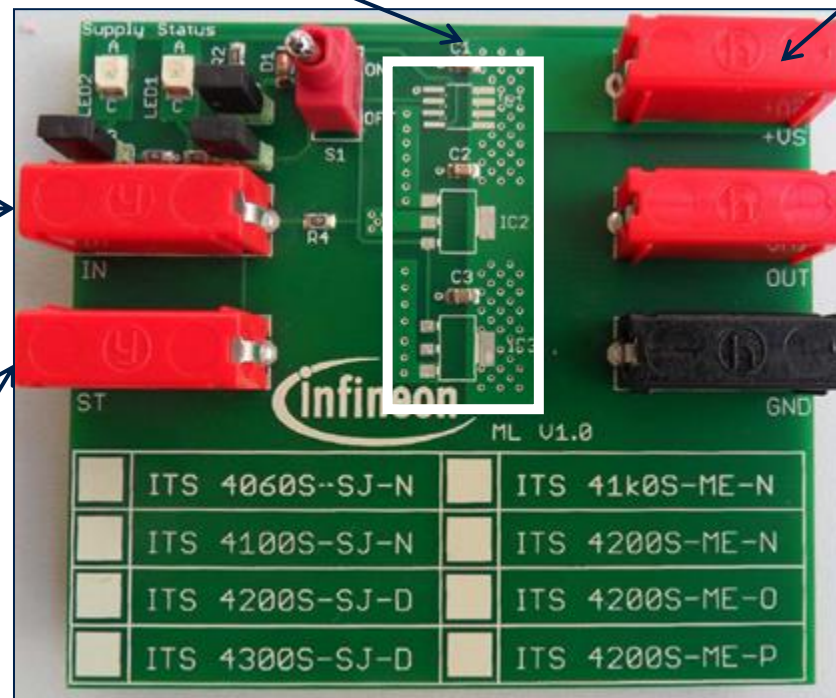

Connect to GND

Diagnosis status feedback for ITS4200S-SJ-D and ITS4300S-SJ-D can be read out via ST. ST goes Low in case of a fault condition. Connect Jumper JP1. LED1 turns ON during a fault condition.

Voltage for gate control at IN could be provided externally via IN or by connecting the +VS to the IN line via Jumper JP2 and switch S1. If an external voltage is provided at banana plug 'IN', JP2 should be left open.

Industrial PROFET™ Universal Application Board Schematic

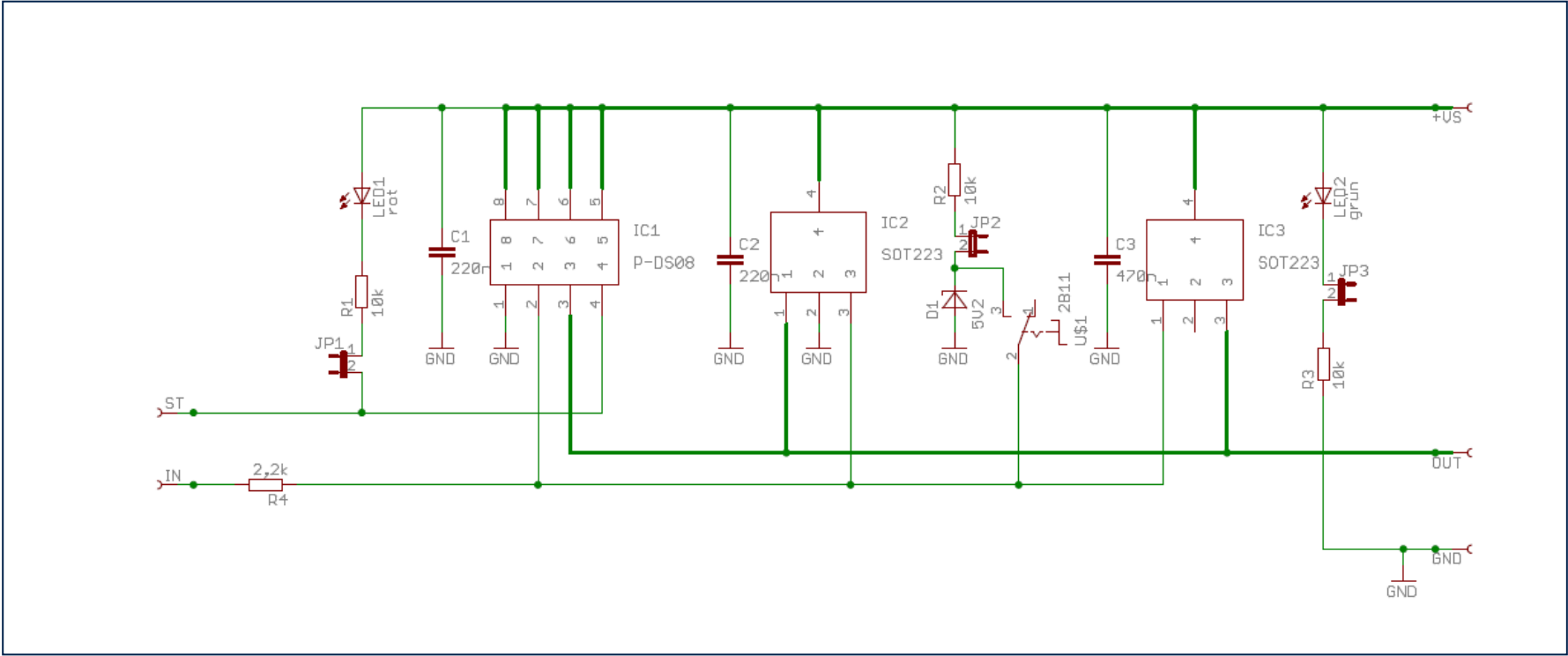

Industrial PROFET™ Universal Application Board Layout

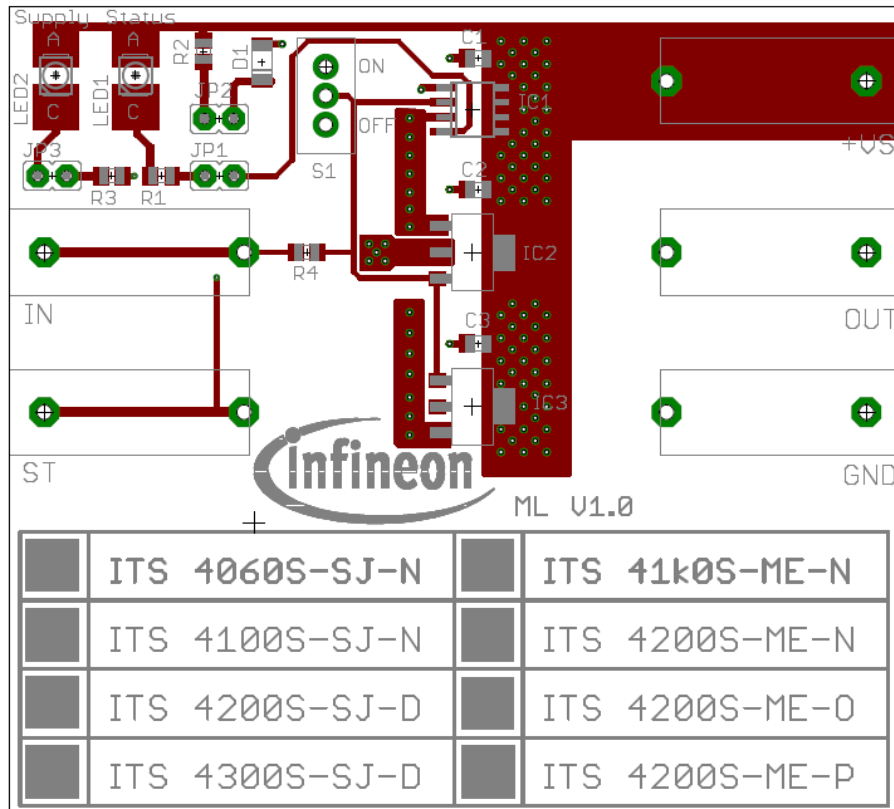

Figure 1. Top View

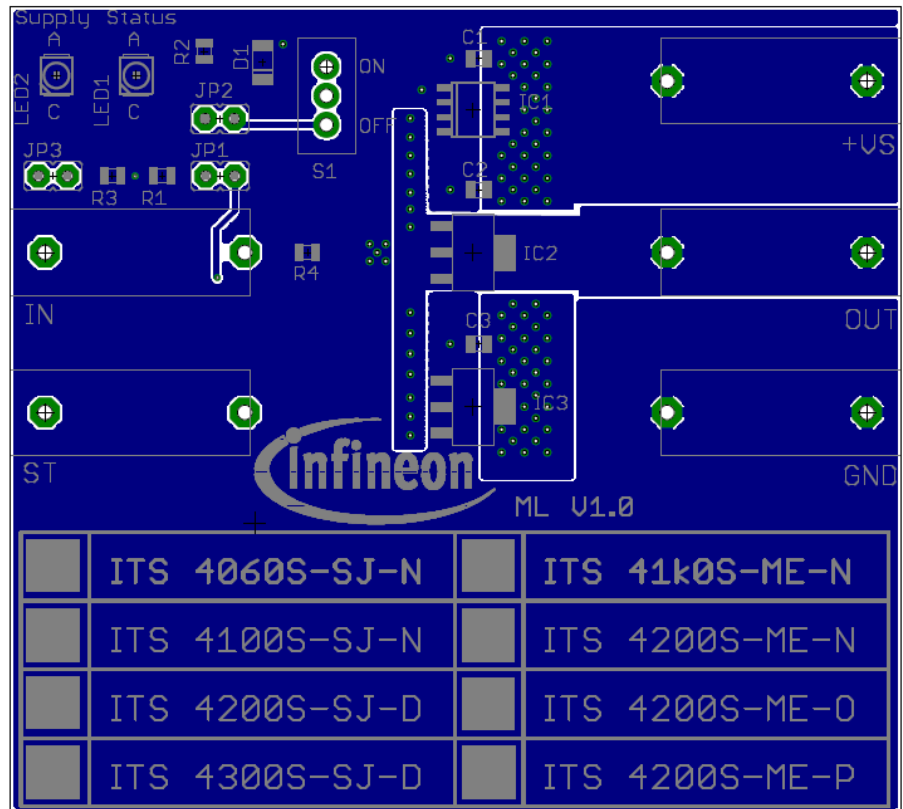

Figure 2. Bottom View

Disclaimer

Edition 2015-06-30
Published by
Infineon Technologies AG
81726 Munich, Germany

© Infineon Technologies AG
All Rights Reserved.

Legal Disclaimer

The information given in this document shall in no event be regarded as a guarantee of conditions or characteristics. With respect to any examples or hints given herein, any typical values stated herein and/or any information regarding the application of the device, Infineon Technologies hereby disclaims any and all warranties and liabilities of any kind, including without limitation, warranties of non-infringement of intellectual property rights of any third party.

Information

For further information on technology, delivery terms and conditions and prices, please contact the nearest Infineon Technologies Office (www.infineon.com)

Warnings

Due to technical requirements, components may contain dangerous substances. For information on the types in question, please contact the nearest Infineon Technologies Office.

The Infineon Technologies component described in this document may be used in life-support devices or systems and/or automotive, aviation and aerospace applications or systems only with the express written approval of Infineon Technologies, if a failure of such components can reasonably be expected to cause the failure of that life-support automotive, aviation and aerospace device or system or to affect the safety or effectiveness of that device or system. Life support devices or systems are intended to be implanted in the human body or to support and/or maintain and sustain and/or protect human life. If they fail, it is reasonable to assume that the health of the user or other persons may be endangered.



ENERGY EFFICIENCY MOBILITY SECURITY

Innovative semiconductor solutions for energy efficiency, mobility and security.

