

Application Note AN-1130

IRS21091 and IR21091 Comparison

By Yuan-Heng Chao, Min Fang, David New

Table of Contents

	Page
Introduction	1
Block Diagrams	2
Electrical Characteristic Differences.....	2
Figures	3
Summary.....	9

Introduction

The IRS21091 is a new HVIC product that replaces the IR21091 HVIC and is pin-to-pin compatible with its predecessor. In many cases, little or no change is necessary to use the new product. This application note describes the differences between the IRS21091 and the IR21091 HVICs.

The IRS21091 is a high voltage, high speed power MOSFET and IGBT driver with dependent high- and low-side referenced output channels. Proprietary HVIC and latch immune CMOS technologies enable ruggedized monolithic construction. The logic input is compatible with standard CMOS or LSTTL output, down to 3.3 V logic. The output drivers feature a high pulse current buffer stage designed for minimum driver cross-conduction. The floating channel can be used to drive an N-channel power MOSFET or IGBT in the high-side configuration which operates up to 600 V.

Block Diagram

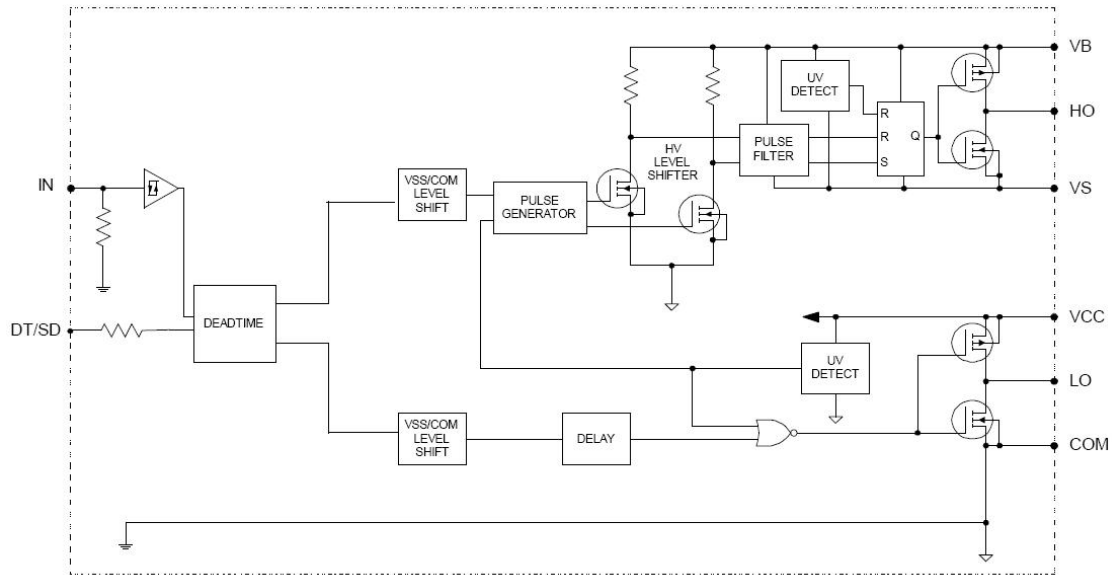

The IRS21091 and IR21091 share the same block diagram. There are no functional changes between the two.

Electrical Characteristic Differences

All measurement conditions remain unchanged unless otherwise noted. Parameters not mentioned in this document have not changed.

Absolute Maximum Ratings

There are no changes in the Absolute Maximum Ratings.

Recommended Operating Conditions

There are no changes in the Recommended Operating Conditions.

Dynamic Electrical Characteristics

Parameter		IR21091			IRS21091			Units
Symbol	Definition	Min.	Typ.	Max.	Min.	Typ.	Max.	
t_{sd}	Shutdown propagation delay	215	-	615	-	200	280	ns
t_r	Turn-on rise time ($V_s = 0$ V)		150	220		100	220	
t_f	Turn-off fall time ($V_s = 0$ V)		50	80		35	80	

The IRS21091 has faster rise and fall times as well as a shorter shutdown propagation delay when compared to the IR21091.

Static Electrical Characteristics

Parameter		IR21091			IRS21091			Units
Symbol	Definition	min	typ	max	min	typ	max	
V_{IH}	Logic "1" input voltage ($V_{CC} = 10$ V to 20 V)	2.9	-	-	2.5	-	-	V
V_{IL}	Logic "0" input voltage ($V_{CC} = 10$ V to 20 V)	-	-	0.8	-	-	0.8	
V_{OH}	High level output voltage, $V_{BIAS} - V_O$	-	0.8	1.4	-	0.05	0.2	
		$I_O = 20$ mA			$I_O = 2$ mA			
V_{OL}	Low level output voltage, V_O	-	0.3	0.6	-	0.02	0.1	
		$I_O = 20$ mA			$I_O = 2$ mA			
I_{QBS}	Quiescent V_{BS} supply current ($I_N = 0$ V or 5 V)	20	60	150	20	75	130	μ A
I_{IN+}	Logic "1" input bias current ($I_N = 5$ V, $DT/SD = 0$ V)	-	5	20	-	5	20	
I_{IN-}	Logic "0" input bias current ($I_N = 0$ V, $DT/SD = 5$ V)	-	1	2	-	-	5	
I_{O+}	Output high short circuit pulsed current ($V_O = 0$ V, $PW \leq 10$ μ s)	120	200	-	120	290	-	mA
I_{O-}	Output low short circuit pulsed current ($V_O = 15$ V, $PW \leq 10$ μ s)	250	350	-	250	600	-	

With the IRS21091,

1. The V_{IH} is reduced to 2.5 V for better 3.3 V logic compatibility.
2. The V_{OH} and V_{OL} are tested using a new standardized test condition of $I_O = 2$ mA. The output driver's on resistance is lower for IRS21091, which improves immunity against the Miller effect.
3. The typical values for I_{O+} and I_{O-} are increased, which allows faster switching.

Figures

The figures shown in this section compare figures shown in the IR21091 (left column) and IRS21091 (right column) datasheets. Illustrations that have not changed between the two datasheets have not been included in this section.

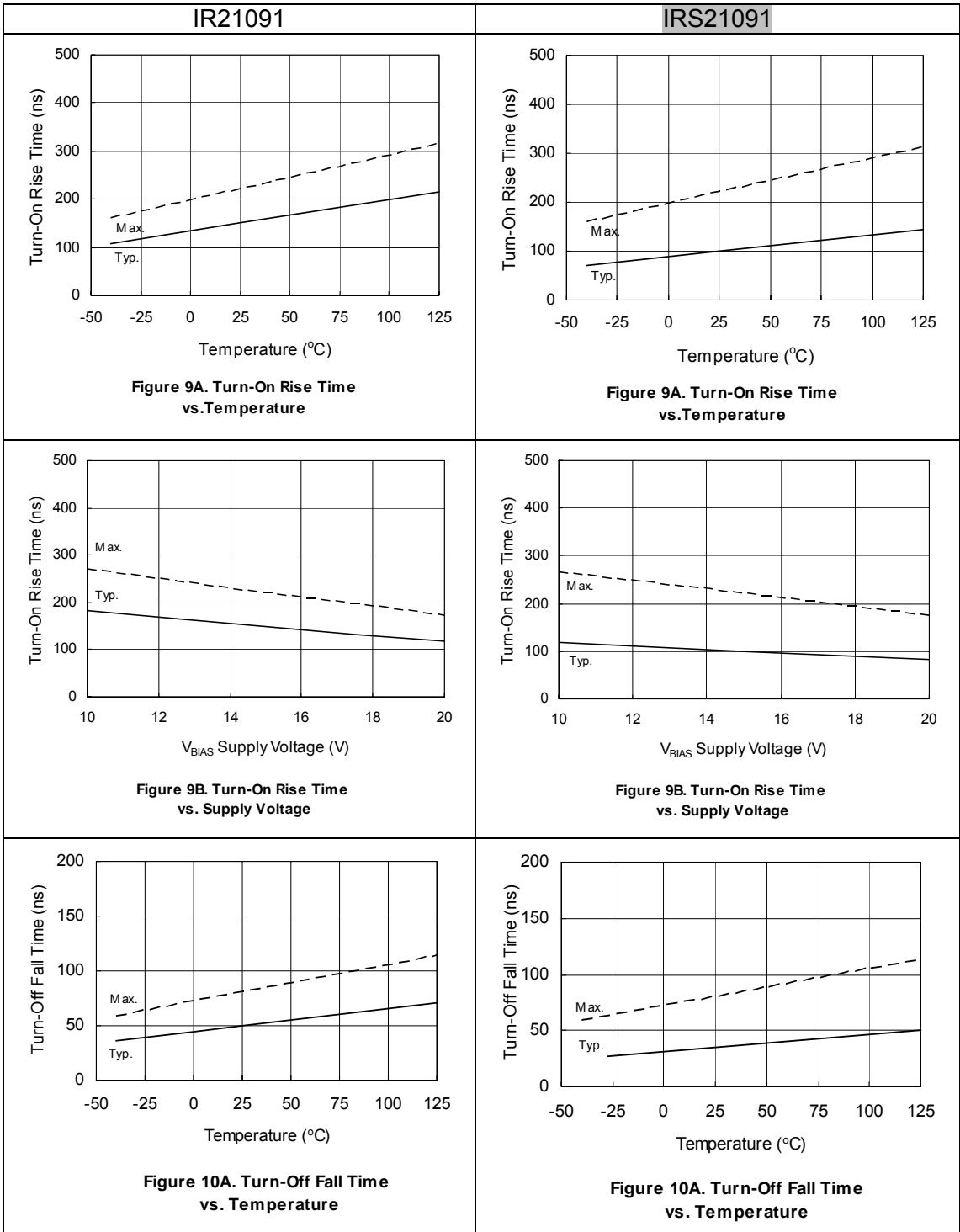

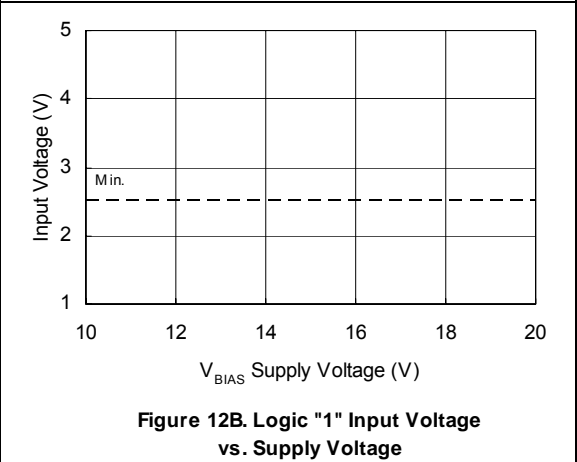
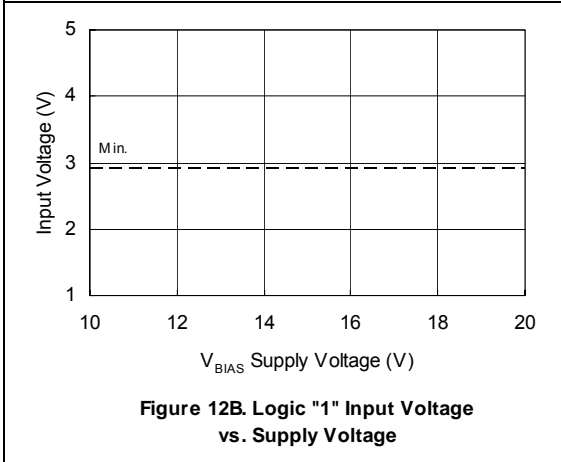
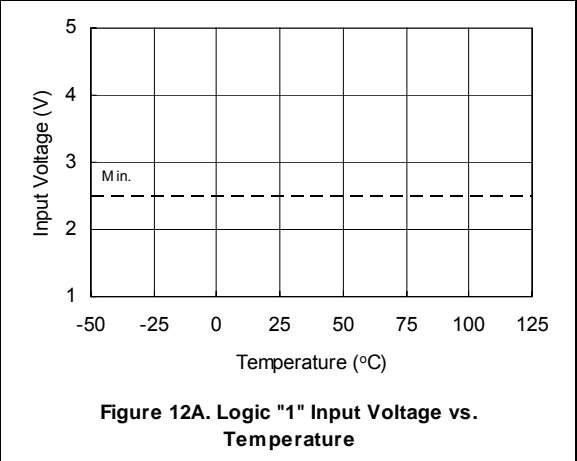
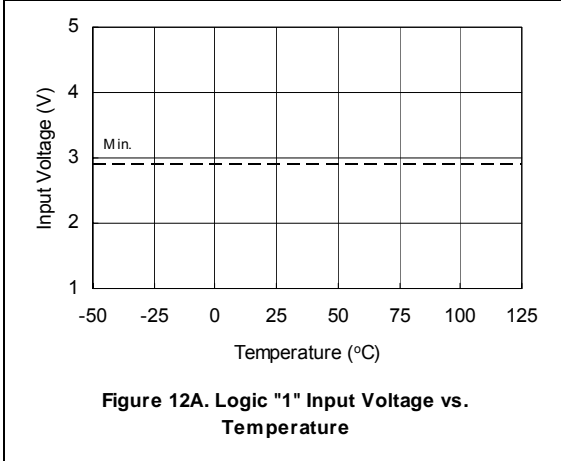
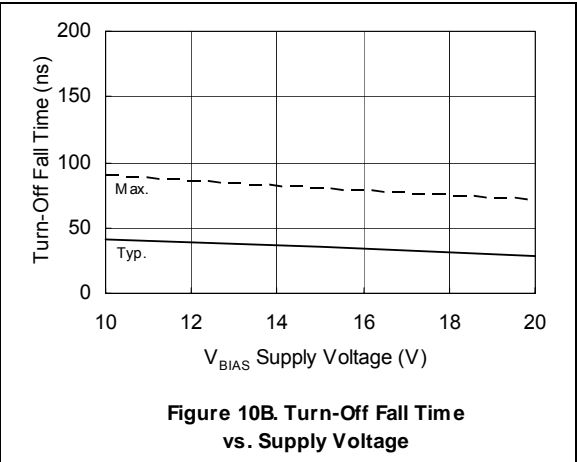
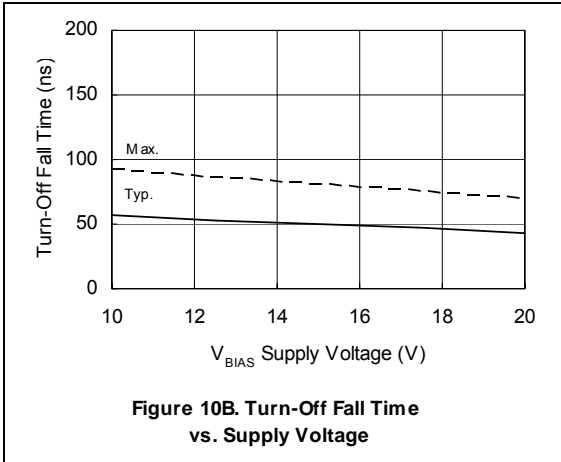

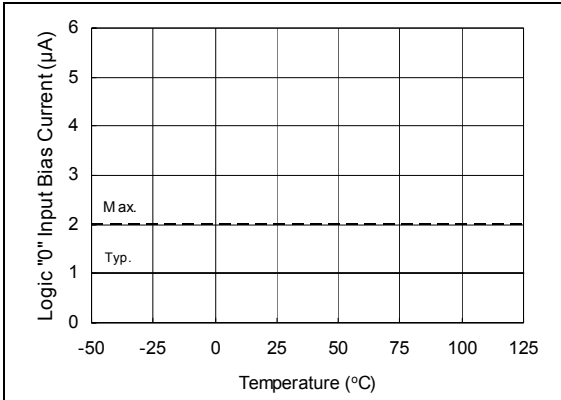

Figure 13A. Logic "0" Input Bias Current vs. Temperature

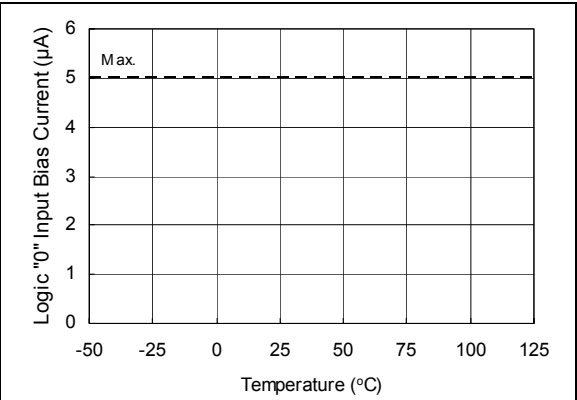

Figure 13A. Logic "0" Input Bias Current vs. Temperature

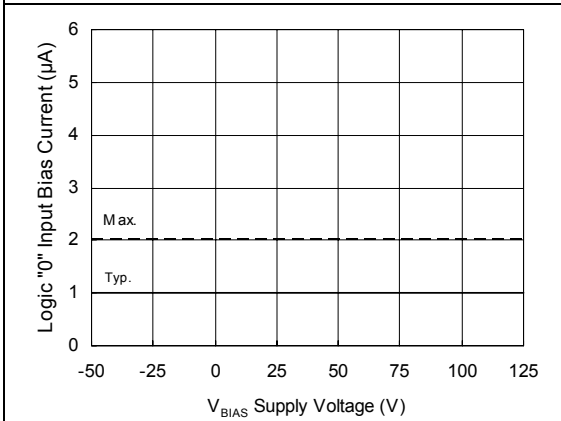

Figure 13A. Logic "0" Input Bias Current vs. Supply Voltage

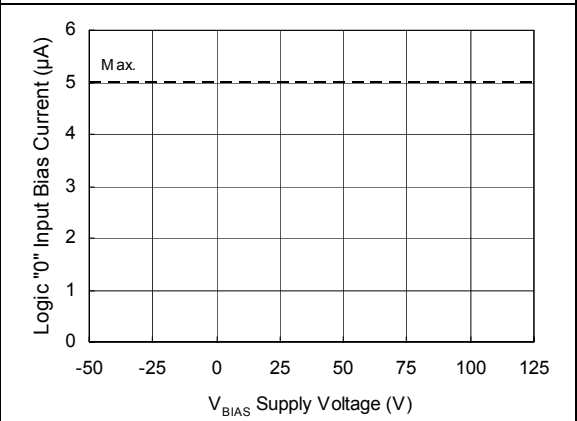

Figure 13A. Logic "0" Input Bias Current vs. Supply Voltage

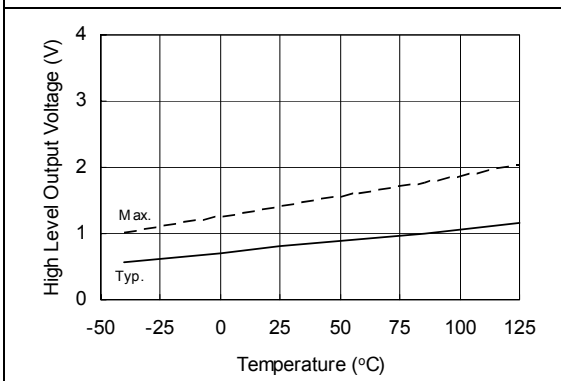

Figure 15A. High Level Output Voltage vs. Temperature

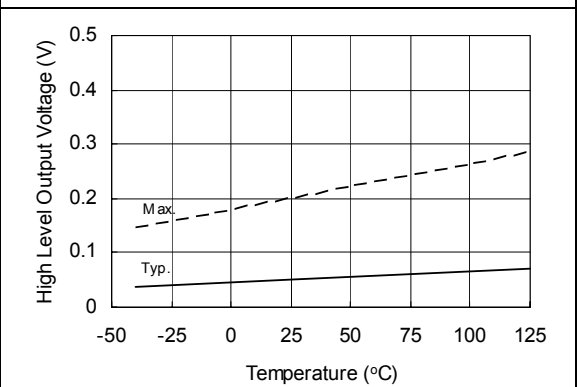
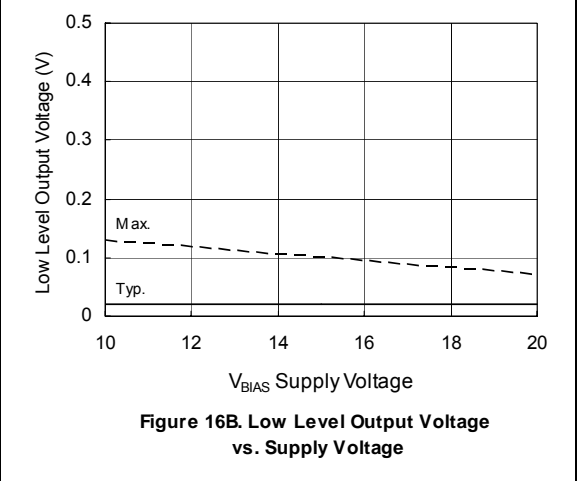
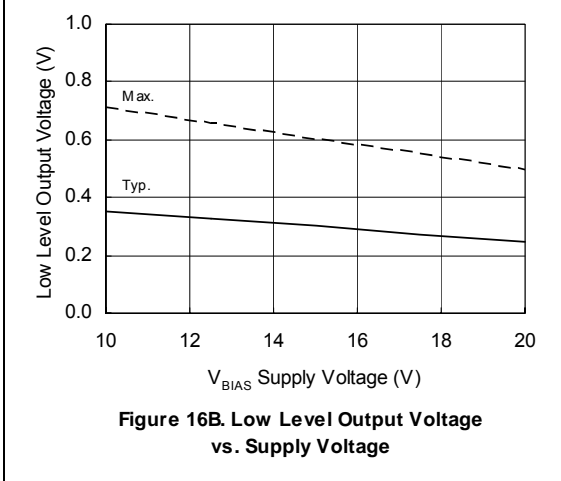
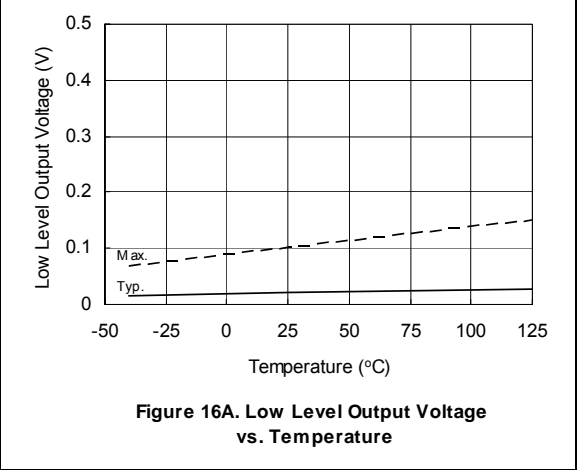
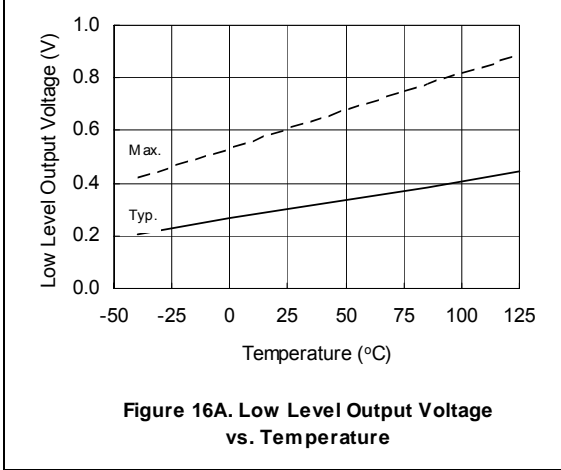
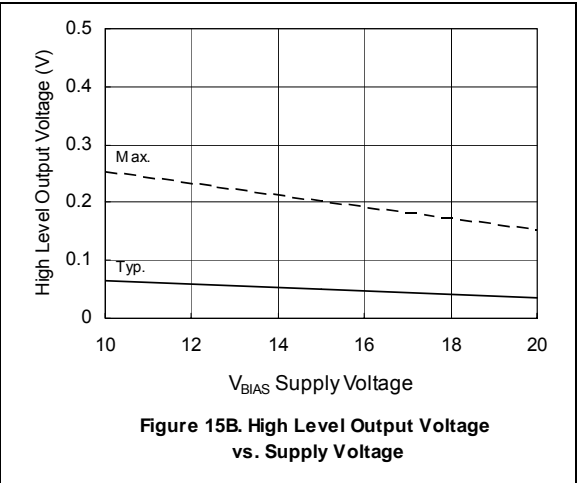
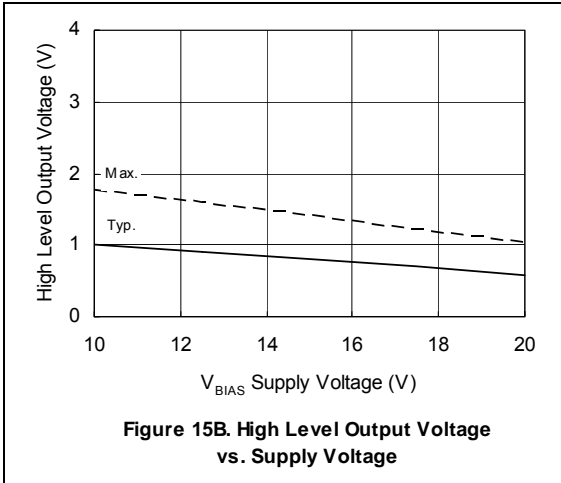
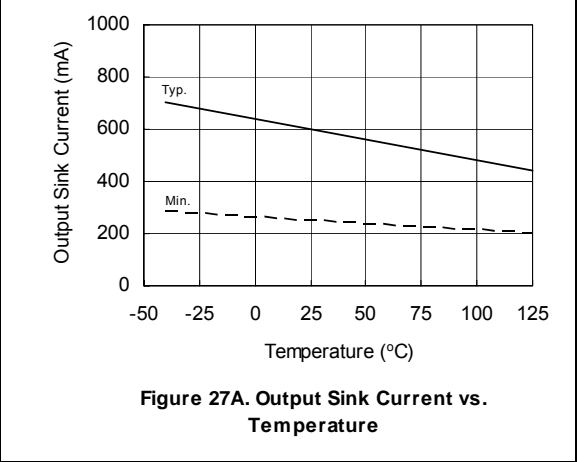
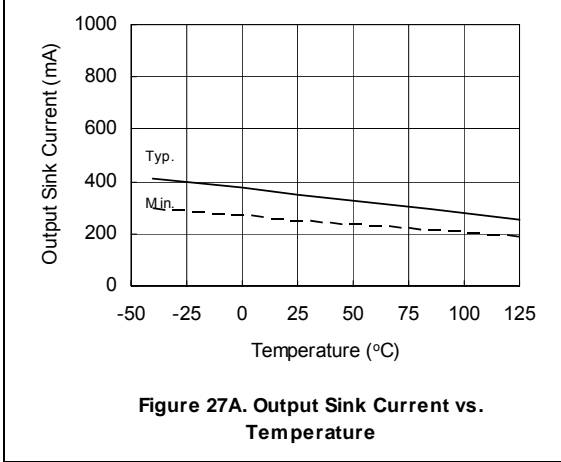
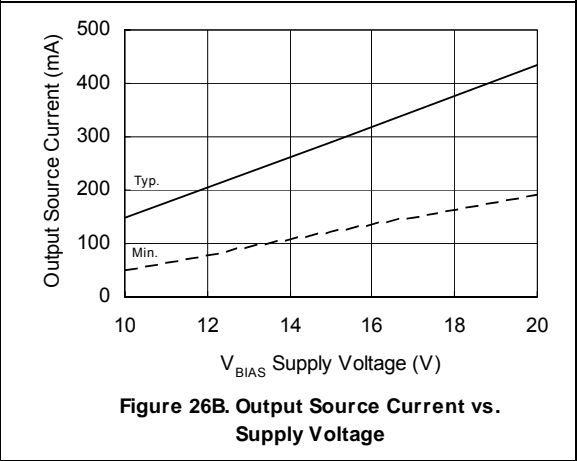
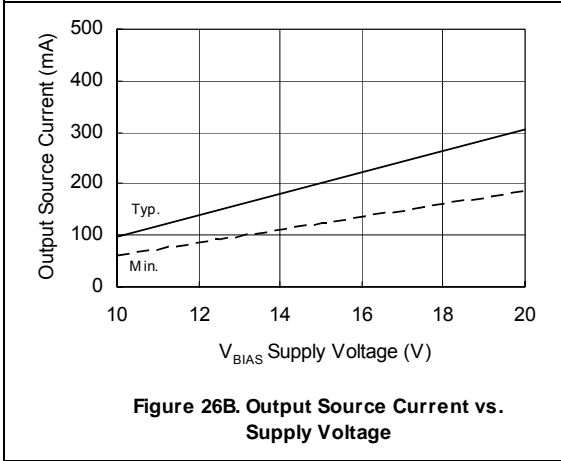
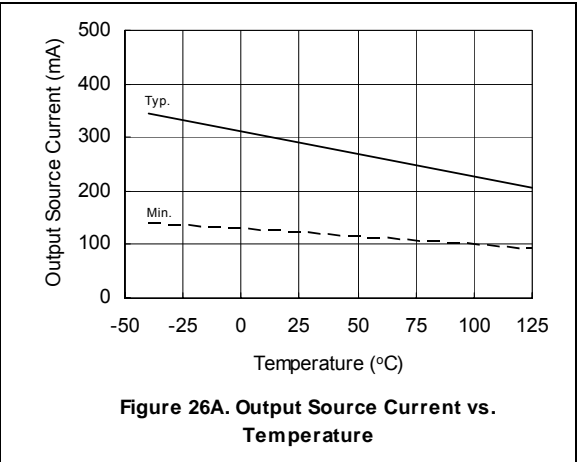
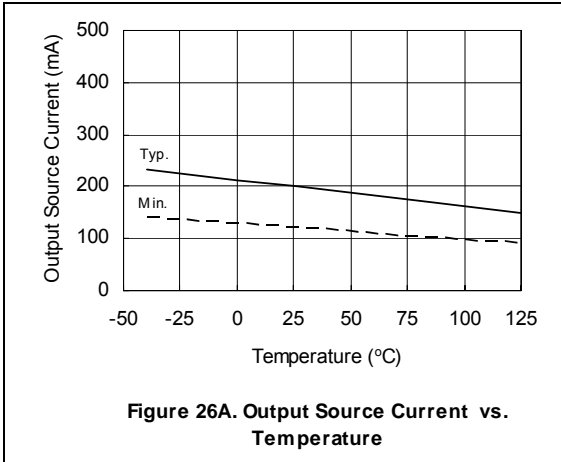
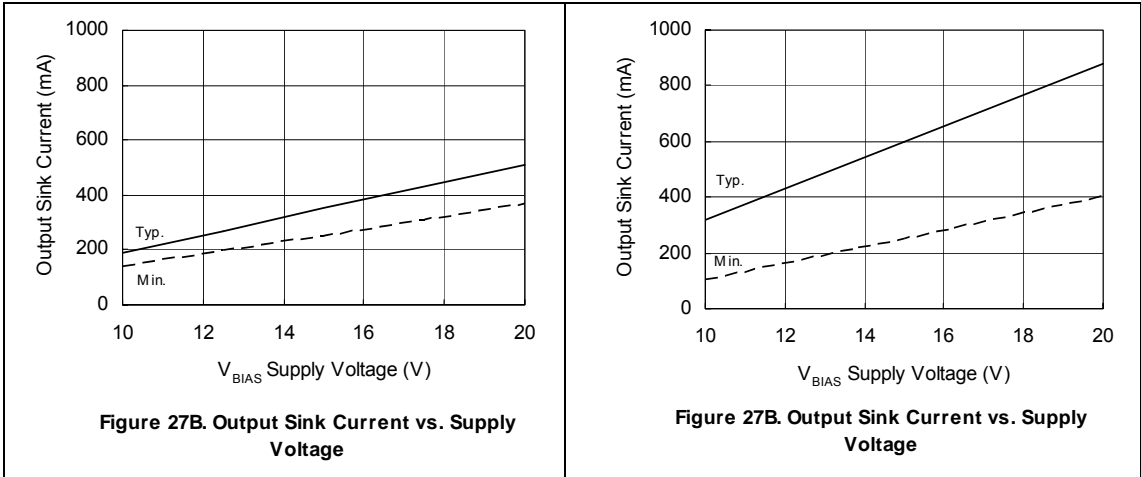

Figure 15A. High Level Output Voltage vs. Temperature







Summary

As shown by this document, the IRS21091 and the IR21091 are very similar with only a few negligible parametric differences.